

[54] **VEHICLE SPEED CONTROL BASED ON GPS/MAP MATCHING OF POSTED SPEEDS**

5,270,708 12/1993 Kamishima 340/995
 5,311,173 5/1994 Komura et al. 364/449
 5,343,780 9/1994 McDaniel et al. 477/108

[75] Inventor: **David Vaughn**, San Jose, Calif.

Primary Examiner—Theodore M. Blum
Attorney, Agent, or Firm—Boris G. Tankhilevich

[73] Assignee: **Trimble Navigation Limited**, Sunnyvale, Calif.

[57] **ABSTRACT**

[21] Appl. No.: **325,130**

The GPS-map speed matching system for controlling the speed of the vehicle is described. The system includes a GPS navigation receiver, a database processing facility, a GPS computer, an engine computer, a video display, a speed sensor and a heading sensor. The database processing facility can be local or remote. The GPS computer obtains the latitude, longitude, heading and speed of the vehicle. The database processing facility processes the GPS data and obtains the location and the maximum posted speed of the vehicle. The GPS computer or an engine computer perform the comparison between the vehicle speed and the maximum posted speed and signal the odometer to decrease the vehicle speed if the vehicle speed exceeds the maximum posted speed plus some predetermined value.

[22] Filed: **Nov. 21, 1994**

[51] **Int. Cl.⁶** **H04B 7/185; G01S 5/02**

[52] **U.S. Cl.** **342/357; 342/457; 364/449; 364/440**

[58] **Field of Search** **342/357, 457; 364/449, 440**

[56] **References Cited**

U.S. PATENT DOCUMENTS

4,651,157	3/1987	Gray et al.	342/457
4,814,711	3/1989	Olsen et al.	342/357
4,818,107	4/1989	Ono et al.	356/375
5,179,519	1/1993	Adachi et al.	364/449

26 Claims, 3 Drawing Sheets

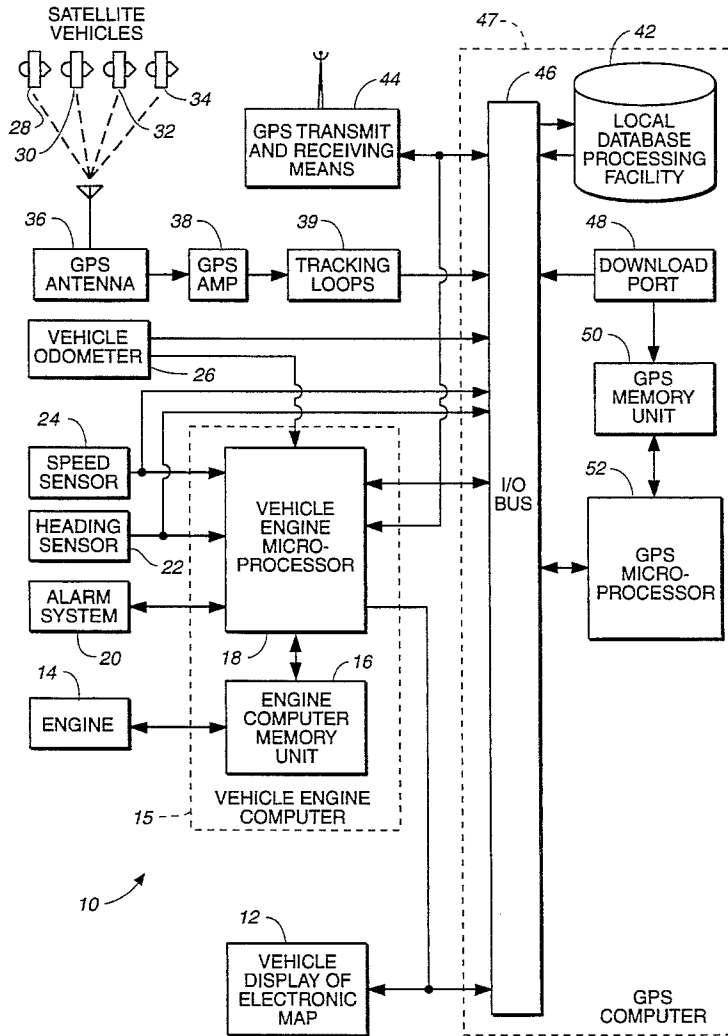

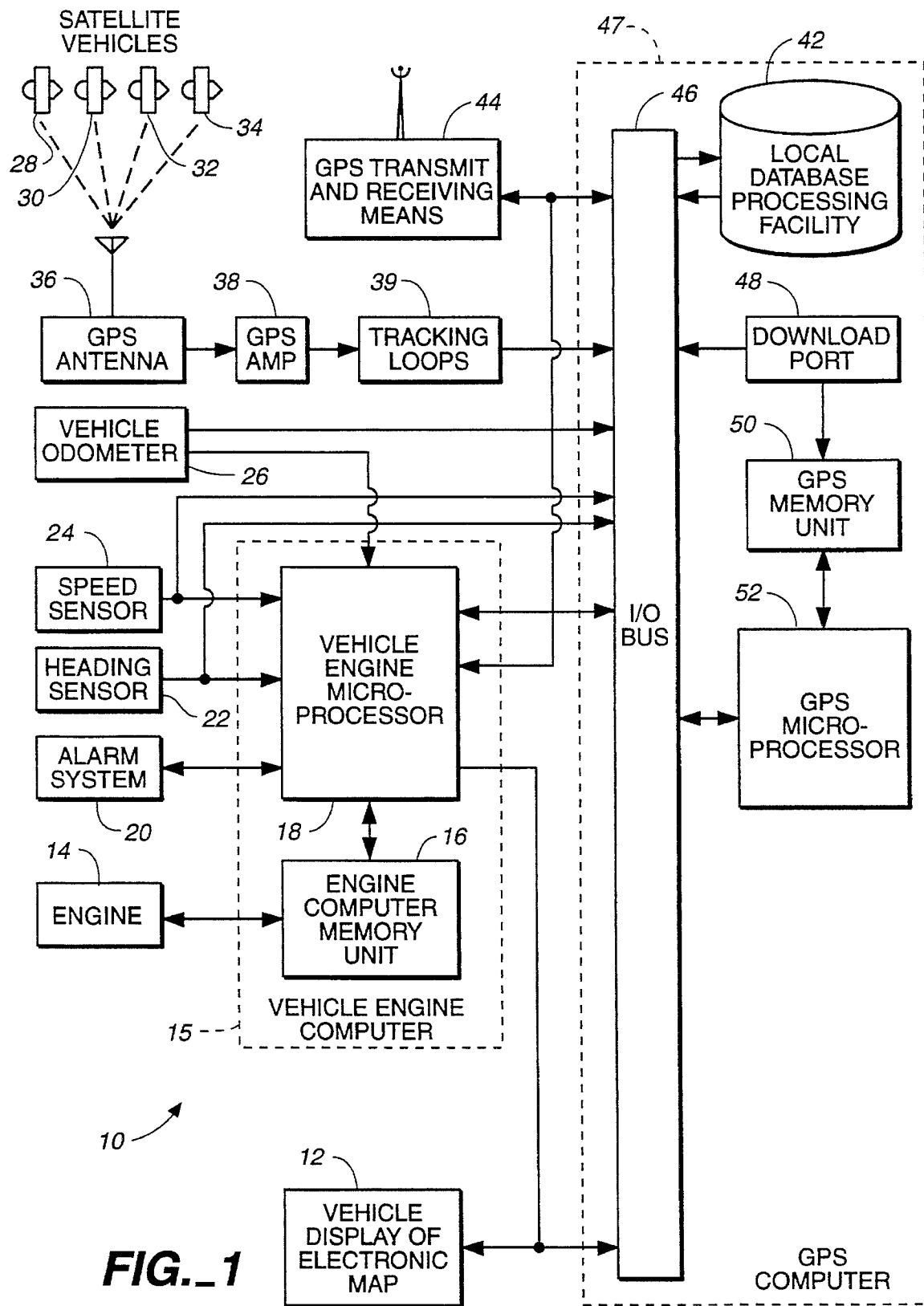
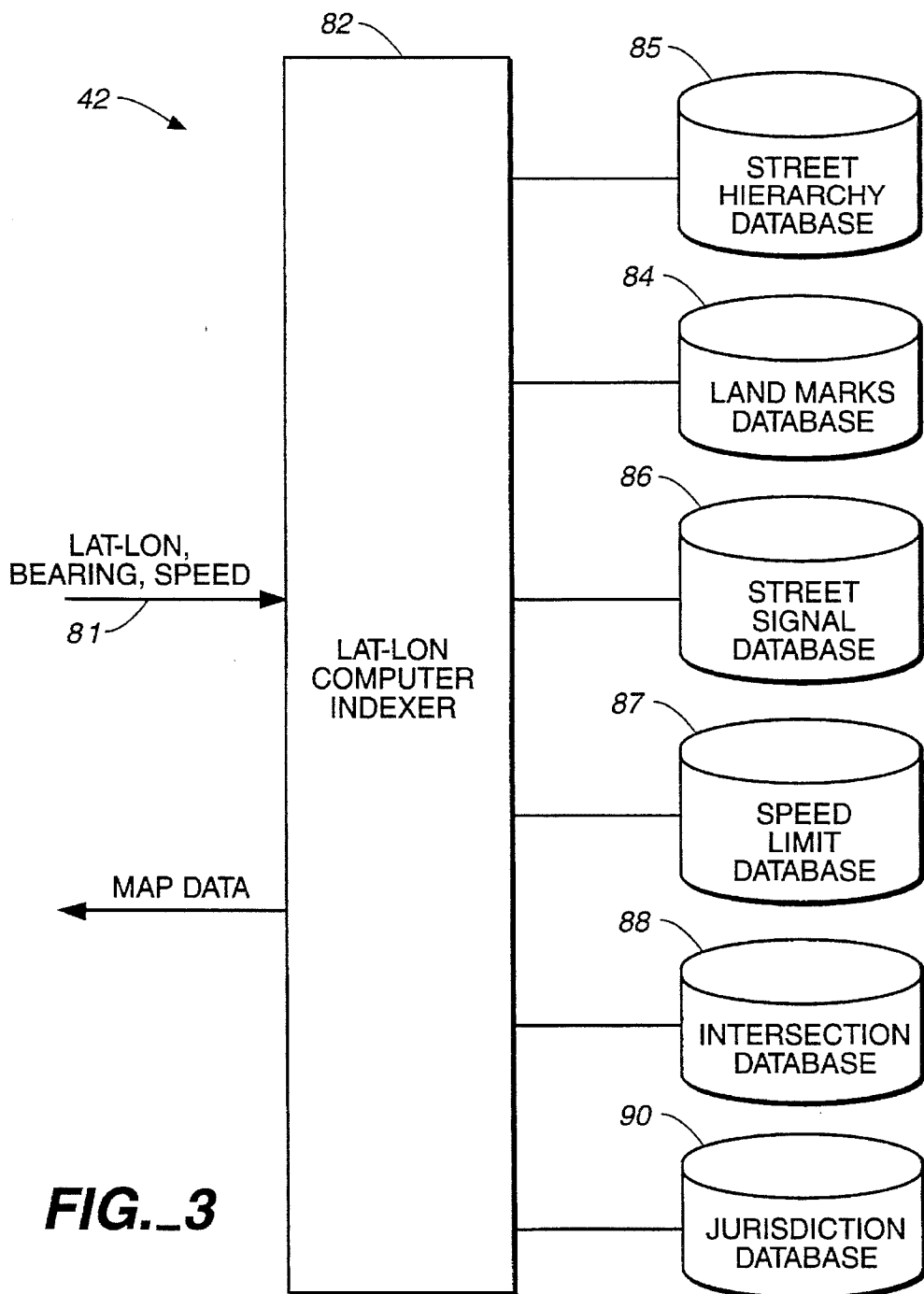
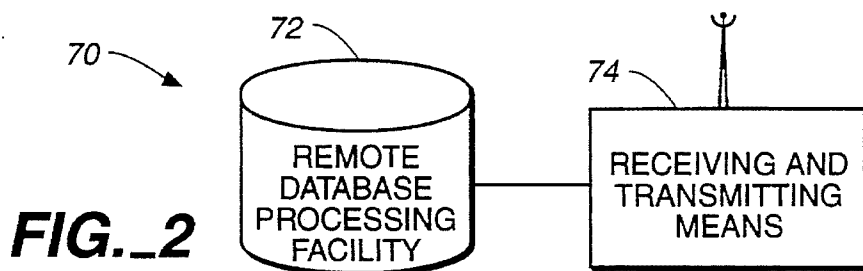

FIG. 1



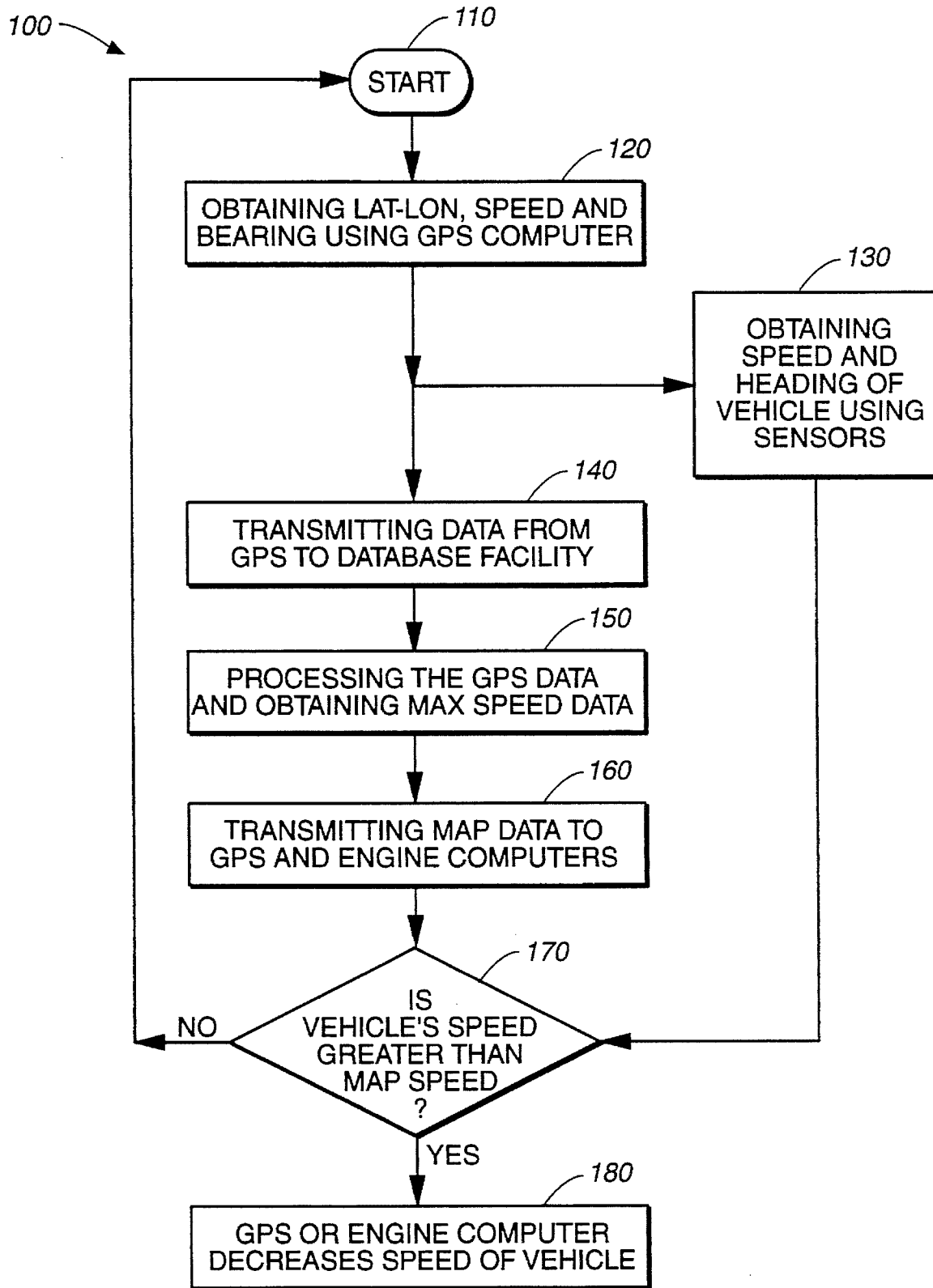

FIG. 4

VEHICLE SPEED CONTROL BASED ON GPS/MAP MATCHING OF POSTED SPEEDS

BACKGROUND

When a vehicle travels the road with the posted speed limit, it is often appropriate to monitor adherence by the vehicle to the posted maximum speed. The adherence does not have to be a strict one. It is sufficient for the vehicle to travel within five-ten miles/hour of the posted maximum speed. Usually the maximum posted speed is enforced by the police road patrol.

Monitoring adherence by the vehicle to a route or schedule is well known in the prior art.

Gray in U.S. Pat. No. 4,651,157 discloses a security monitoring and tracking system for a terrestrial or marine vehicle that uses navigational information to determine the latitude and longitude of the vehicle.

U.S. Pat. No. 4,814,711, issued to Olsen, discloses a survey system for collection of real time data from a plurality of survey vehicles, each of which determines its present location using global positioning system (GPS) signals received from a plurality of GPS satellites. A central station periodically polls each survey vehicle and receives that survey vehicle's present location coordinates by radio wave communication. The central station compares that vehicle's path with a survey pattern assigned to that vehicle. The geophysical data measured by a vehicle are also received by the central station and are coordinated with that vehicle's location at the time it was taken.

Harker discloses in U.S. Pat. No. 5,177,684 a method for analyzing transportation schedules of a transportation vehicle to produce optimized schedules. The method uses information on the vehicle's assigned path and the average speed and mobility of the vehicle, and determines a realistic, optimum schedule, including arrival and departure times, that the vehicle can adhere to along that path.

U.S. Pat. No. 5,243,530 issued to Stanifer discloses a system for tracking a plurality of terrestrial, marine or airborne vehicles, using a local area network and packet communication of location information. Loran-C signals are received by a receiver/processor/transmitter on a vehicle, the vehicle's present location is determined, and this location information is transmitted to a central station, using LAN packet protocols, acknowledgment signals and backoff/retransmission procedures that are standard in the LAN art. If a given vehicle's present location is not received by the central station within a time interval of selected length, the central station requests transmission of the present location from that vehicle.

What is needed is an approach that allows one to automatically match the vehicle's speed with the maximum posted speed and to control the vehicle's speed if it substantially exceeds the posted limit. It would allow enforcement of the vehicle's maximum speed without the police patrol or with reduced police patrol, which is of interest to owners of fleets of vehicles, such as trucking companies. Such compliance would save the fleet owners money.

SUMMARY

The present invention is unique because it allows one to control the vehicle speed by using the Global Positioning System to determine the vehicle location, and to use locally stored map database to match the vehicle location and speed with the maximum posted speed limit. Accordingly, the

speed of the vehicle is controlled and the posted speed is enforced without using the police patrol.

One aspect of the present invention is directed to an apparatus for controlling the maximum speed of a vehicle based on the speed limits posted on the street on which the vehicle is travelling. The apparatus includes a GPS navigation computer and receiver with an earth navigation format data output, a vehicle engine computer connected to said navigation computer, and a map database. The GPS navigation computer includes a GPS associated memory unit. The GPS navigation computer includes a port for downloading map data from the map database into the memory unit for original installation and for updating and changes. The GPS navigation computer determines location and speed of the vehicle, inputs the maximum speed from the map database, and forwards the speed limit to the engine computer, wherein the engine computer uses the speed limit information contained in the map database to limit the maximum ground speed of the vehicle. The apparatus further includes a vehicle display of an electronic map connected to the GPS computer for electronically displaying the map with the posted speed limit, the current location of the vehicle on the map and the current speed of the vehicle.

The apparatus further includes a speed sensor and a heading sensor. These sensors are connected to the vehicle odometer for reading speed and heading of the vehicle and to the GPS computer and to the vehicle engine computer for transmitting the reading of speed and heading of the vehicle. The vehicle engine computer further includes an engine computer memory and an engine microprocessor, wherein said vehicle engine computer is connected to the GPS computer to receive the value of the maximum map speed limit from the map data.

In one embodiment the engine computer memory contains a predetermined speed value which is added to the maximum speed map limit to obtain the real maximum speed value of the vehicle. The vehicle engine computer is connected to the vehicle odometer to control the real maximum speed value of the vehicle.

In another embodiment the GPS memory unit contains a predetermined speed value which is added to the maximum speed map limit to obtain the real maximum speed value of the vehicle. The GPS computer is connected to the vehicle engine computer to control the real maximum speed value of the vehicle.

In one embodiment the map database includes a local database processing facility connected to the port by a hard wired connection for downloading map data from one particular database. It is connected to the GPS computer by a hard wired connection for receiving longitude, latitude, speed and bearing of the vehicle. The database processing facility comprises a plurality of specialized databases that include relational data expressed in earth navigation format, an indexer connected to specialized databases for selecting access to a particular database according to the position descriptor related in this particular database to the vehicle location, wherein the vehicle location and speed are determined by the GPS computer and are transmitted to the database processing facility. The plurality of specialized databases further includes data for relational access that is in a latitude and longitude format.

In another embodiment the database processing facility includes a remote database processing facility. In this embodiment, the GPS computer further includes a GPS transmitting means for a wireless transmission of the position, speed and heading data of the vehicle to the remote

Explore Litigation Insights

Docket Alarm provides insights to develop a more informed litigation strategy and the peace of mind of knowing you're on top of things.

Real-Time Litigation Alerts



Keep your litigation team up-to-date with **real-time alerts** and advanced team management tools built for the enterprise, all while greatly reducing PACER spend.

Our comprehensive service means we can handle Federal, State, and Administrative courts across the country.

Advanced Docket Research



With over 230 million records, Docket Alarm's cloud-native docket research platform finds what other services can't. Coverage includes Federal, State, plus PTAB, TTAB, ITC and NLRB decisions, all in one place.

Identify arguments that have been successful in the past with full text, pinpoint searching. Link to case law cited within any court document via Fastcase.

Analytics At Your Fingertips



Learn what happened the last time a particular judge, opposing counsel or company faced cases similar to yours.

Advanced out-of-the-box PTAB and TTAB analytics are always at your fingertips.

API

Docket Alarm offers a powerful API (application programming interface) to developers that want to integrate case filings into their apps.

LAW FIRMS

Build custom dashboards for your attorneys and clients with live data direct from the court.

Automate many repetitive legal tasks like conflict checks, document management, and marketing.

FINANCIAL INSTITUTIONS

Litigation and bankruptcy checks for companies and debtors.

E-DISCOVERY AND LEGAL VENDORS

Sync your system to PACER to automate legal marketing.