

(12) **United States Patent**  
**Fouche**

(10) **Patent No.:** **US 6,751,529 B1**  
 (45) **Date of Patent:** **Jun. 15, 2004**

- (54) **SYSTEM AND METHOD FOR CONTROLLING MODEL AIRCRAFT**
- (75) Inventor: **J. Michael Fouche**, Huntsville, AL (US)
- (73) Assignee: **Neural Robotics, Inc.**, Huntsville, AL (US)
- (\* ) Notice: Subject to any disclaimer, the term of this patent is extended or adjusted under 35 U.S.C. 154(b) by 0 days.

(21) Appl. No.: **10/449,372**  
 (22) Filed: **May 30, 2003**

**Related U.S. Application Data**

- (60) Provisional application No. 60/385,315, filed on Jun. 3, 2002.
- (51) **Int. Cl.<sup>7</sup>** ..... **B64C 11/34**
- (52) **U.S. Cl.** ..... **701/3**; 244/3.21; 244/164; 244/171; 342/29; 340/967
- (58) **Field of Search** ..... 701/3, 4, 7, 48; 244/3.21, 164, 171, 181, 183, 158 R, 177, 179; 342/29, 30; 340/967, 975, 978

(56) **References Cited**

**U.S. PATENT DOCUMENTS**

5,553,812 A	*	9/1996	Gold et al.	244/76 R
5,797,105 A	*	8/1998	Nakaya et al.	701/7
5,841,537 A	*	11/1998	Doty	356/484
6,092,919 A		7/2000	Calise et al.	
6,473,676 B2	*	10/2002	Katz et al.	701/4

**OTHER PUBLICATIONS**

Buschek, H.; Calise, A.J., “ $\mu$  Controllers: Mixed and Fixed”, *AIAA J. of Guidance, Control, and Dynamics*, vol. 20, No. 1, pp. 34–41, 1997.  
 Robinson, Rick, “Better than Human Flight Control Systems”, *Research Horizons*, Winter 2000, found at <http://gtresearchnews.gatech.edu/reshor/rh-win00/flight.html>.

Sugeno, Michio, “Demonstration of Unmanned Helicopter with Fuzzy Control”, 1993, found at <http://www.cs.arizona.edu/japan/www/atip/public/atip.reports.95/atip95.13r.html>.  
 Sugeno, Michio, “Fuzzy Logic Controller in an Intelligent, Unmanned Helicopter”, 1995, found at <http://www.cs.arizona.edu/japan/www/atip/public/atip.reports.94/sugeno.94.html>.  
 Bluck, John, “NASA Testing New Aircraft Safety Flight Control Software”, Release 99–21AR, Apr. 14, 1999, found at [http://amesnews.arc.nasa.gov/releases/1999/99\\_21AR.html](http://amesnews.arc.nasa.gov/releases/1999/99_21AR.html).

(List continued on next page.)

*Primary Examiner*—Thomas G Black  
*Assistant Examiner*—Tuan C To  
 (74) *Attorney, Agent, or Firm*—Lanier Ford Shaver & Payne P.C.

(57) **ABSTRACT**

In one embodiment, a method for controlling an aircraft comprises providing an attitude error as a first input into a neural controller and an attitude rate as a second input into the neural controller. The attitude error is calculated from a commanded attitude and a current measured attitude, and the attitude rate is derived from the current measured attitude. The method also comprises processing the first input and the second input to generate a commanded servo actuator rate as an output of the neural controller. The method further comprises generating a commanded actuator position from the commanded servo actuator rate and a current servo position, and inputting the commanded actuator position to a servo motor configured to drive an attitude actuator to the commanded actuator position. The neural controller is developed from a neural network, wherein the neural network is designed without using conventional control laws, and the neural network is trained to eliminate the attitude error.

**28 Claims, 16 Drawing Sheets**

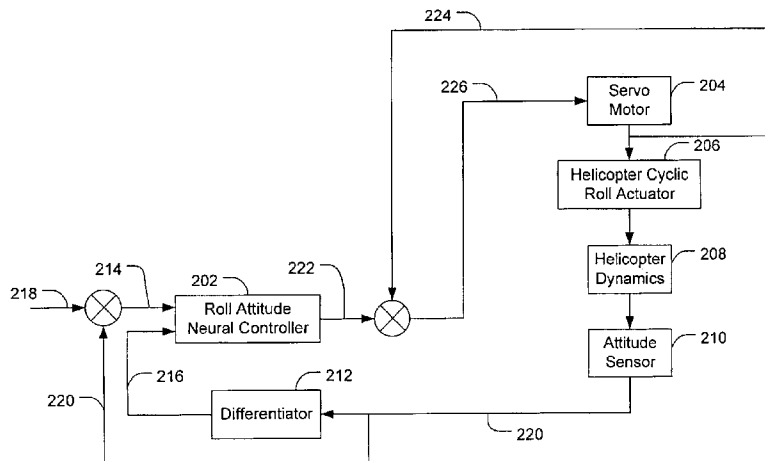

OTHER PUBLICATIONS

Saeks, Richard, LoFlyte information found at <http://www.accurate-automation.com/Technology/Loflyte/loflyte.html>.

Rolf, Rysdyk T.; Calise, A.J., "Nonlinear Adaptive Flight Control Using Neural Networks", *IEEE Controls Systems Magazine*, vol. 18, No. 6, Dec. 1998.

Leitner, Jesse; Calise, Anthony J.; Prasad, J.V.R., "Analysis of Adaptive Neural Networks for Helicopter Flight Controls", *AIAA Journal of Guidance, Control, and Dynamics*, vol. 20, No. 5, p. 972-979, Sep.-Oct. 1997.

\* cited by examiner

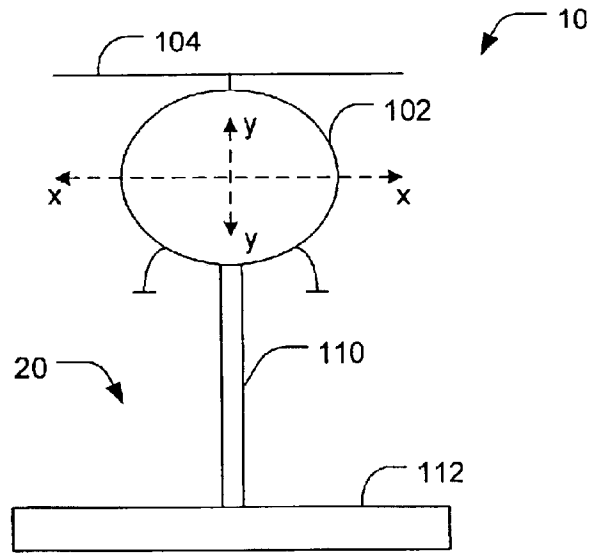

(Front View)

**FIG. 1A**

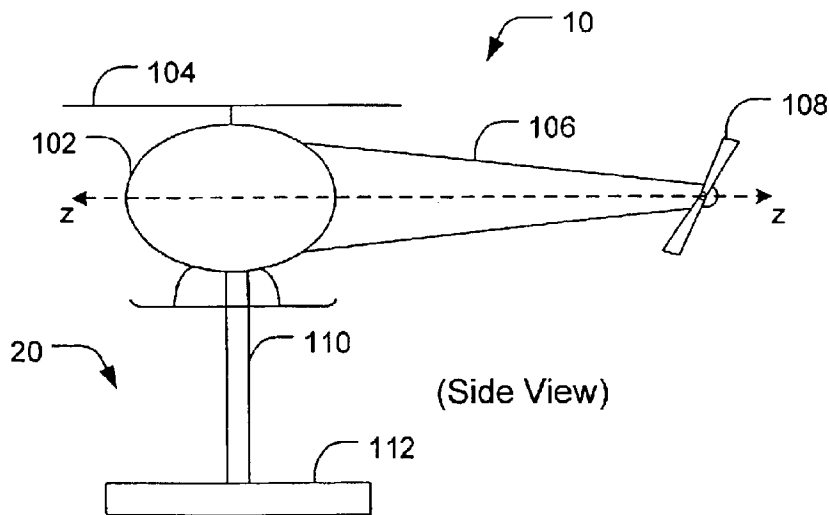

(Side View)

**FIG. 1B**

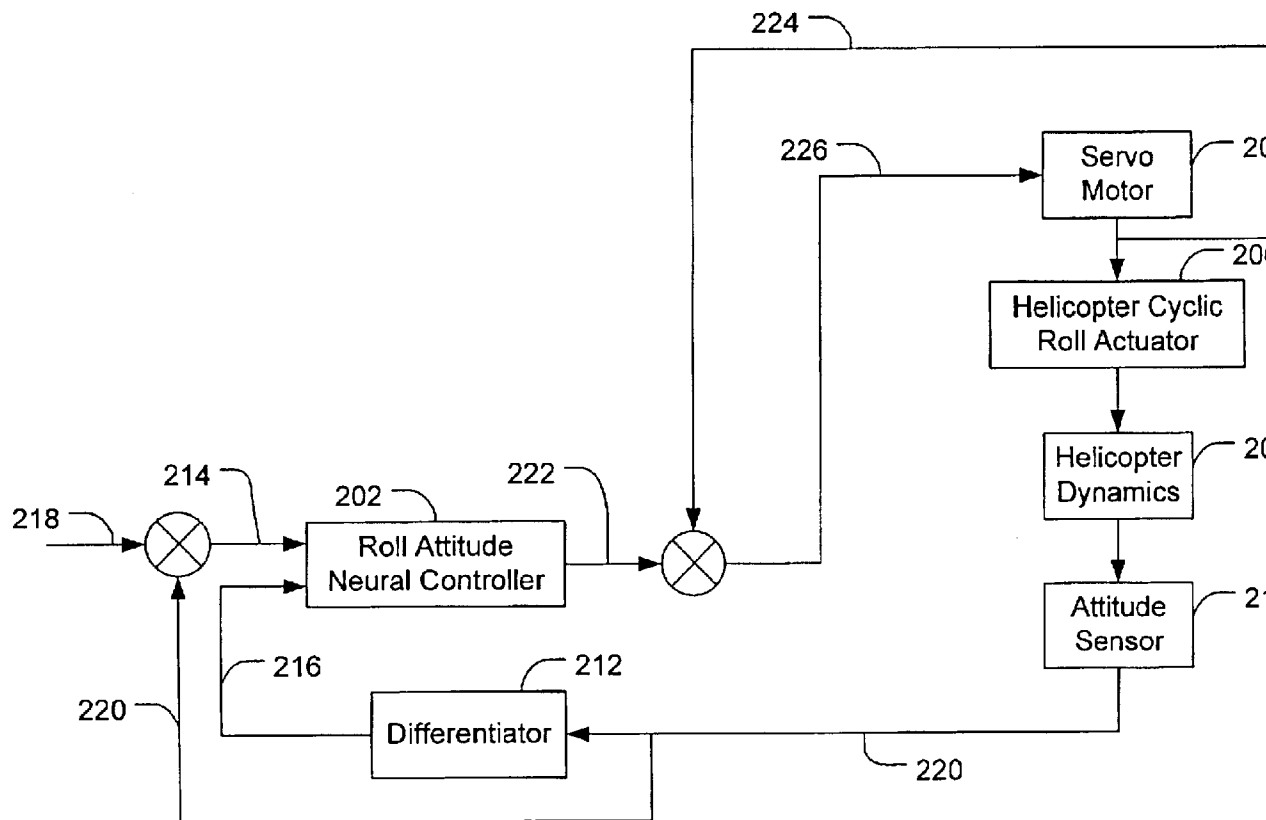

**FIG. 2**

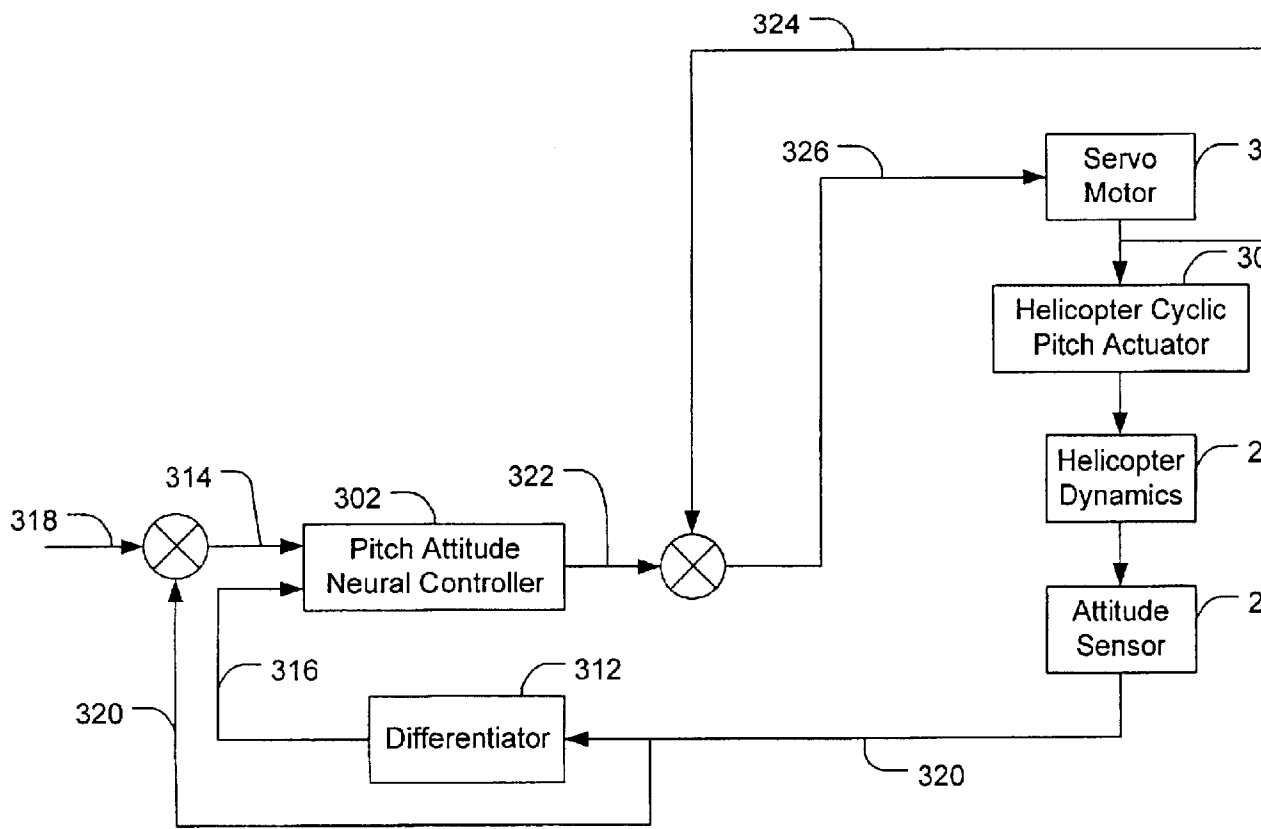

**FIG. 3**

# Explore Litigation Insights

Docket Alarm provides insights to develop a more informed litigation strategy and the peace of mind of knowing you're on top of things.

## Real-Time Litigation Alerts



Keep your litigation team up-to-date with **real-time alerts** and advanced team management tools built for the enterprise, all while greatly reducing PACER spend.

Our comprehensive service means we can handle Federal, State, and Administrative courts across the country.

## Advanced Docket Research



With over 230 million records, Docket Alarm's cloud-native docket research platform finds what other services can't. Coverage includes Federal, State, plus PTAB, TTAB, ITC and NLRB decisions, all in one place.

Identify arguments that have been successful in the past with full text, pinpoint searching. Link to case law cited within any court document via Fastcase.

## Analytics At Your Fingertips



Learn what happened the last time a particular judge, opposing counsel or company faced cases similar to yours.

Advanced out-of-the-box PTAB and TTAB analytics are always at your fingertips.

## API

Docket Alarm offers a powerful API (application programming interface) to developers that want to integrate case filings into their apps.

## LAW FIRMS

Build custom dashboards for your attorneys and clients with live data direct from the court.

Automate many repetitive legal tasks like conflict checks, document management, and marketing.

## FINANCIAL INSTITUTIONS

Litigation and bankruptcy checks for companies and debtors.

## E-DISCOVERY AND LEGAL VENDORS

Sync your system to PACER to automate legal marketing.