

UNITED STATES PATENT AND TRADEMARK OFFICE

BEFORE THE PATENT TRIAL AND APPEAL BOARD

PARROT S.A. and PARROT, INC.,
Petitioner,

v.

DRONE TECHNOLOGIES, INC.,
Patent Owner.

Case IPR2014-00732
Patent 8,106,748 B2

Before HOWARD B. BLANKENSHIP, MATTHEW R. CLEMENTS, and
CHRISTOPHER M. KAISER, *Administrative Patent Judges*.

BLANKENSHIP, *Administrative Patent Judge*.

DECISION
Institution of *Inter Partes* Review
37 C.F.R. § 42.108

I. BACKGROUND

Parrot S.A. and Parrot, Inc. (collectively, “Petitioner”) filed a petition requesting *inter partes* review of claims 1–12 of U.S. Patent No. 8,106,748 B2 (Ex. 1001, “the ’748 patent”) under 35 U.S.C. §§ 311–319. Paper 1 (“Petition” or “Pet.”). Patent Owner, Drone Technologies, Inc., filed a

preliminary response as permitted by 37 C.F.R. § 42.107. Paper 7 (“Prelim. Resp.”). We have jurisdiction under 35 U.S.C. § 314. Section 314 provides that an *inter partes* review may not be instituted “unless . . . the information presented in the petition . . . shows that there is a reasonable likelihood that the petitioner would prevail with respect to at least 1 of the claims challenged in the petition.”

For the reasons that follow, we institute an *inter partes* review as to claims 1–12 of the ’748 patent.

A. Related Proceedings

According to Petitioner, the ’748 patent is involved in the following lawsuit: *Drone Technologies, Inc. v. Parrot S.A.*, No. 2:05-mc-02025 (W.D. Pa.). Pet. 4.

B. The ’748 Patent

The ’748 patent relates to a remote control system in which a remote control apparatus transmits a target motion signal to a remote-controlled motion apparatus. Ex. 1001, Abstract.

Figure 5 of the ’748 patent is reproduced below.

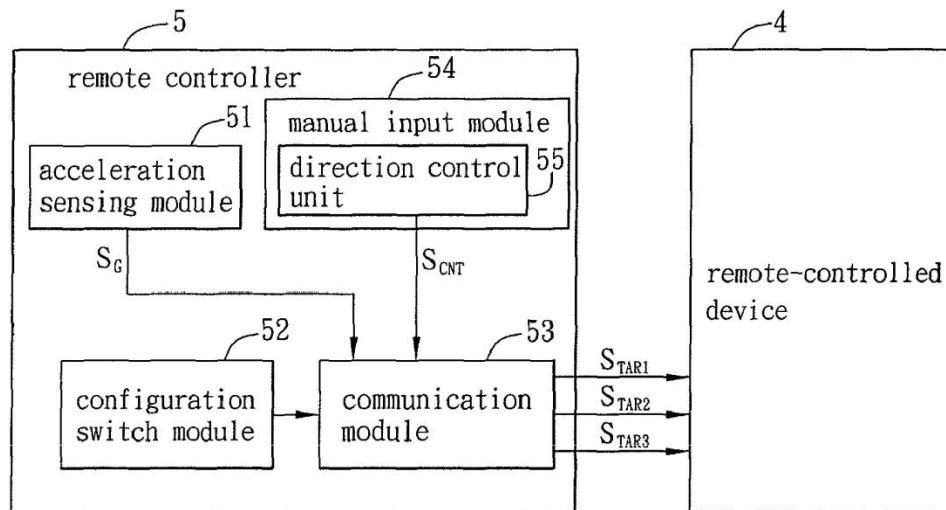

FIG. 5

Figure 5 is a system diagram of a remote control system. Ex. 1001, col. 3, ll. 7–9. Remote controller 5 comprises acceleration sensing module 51, communication module 53, and manual input module 54. In the first operation mode, acceleration sensing module 51 detects the acceleration of remote controller 5 and outputs acceleration sensing signal S_G . Communication module 53 connects to acceleration sensing module 51 and transmits first target motion signal S_{TAR1} according to the acceleration sensing signal. First target motion signal S_{TAR1} controls the motion of remote-controlled device 4 to align with the acceleration sensing signal. *Id.* at col. 5, ll. 54–67.

In the second operation mode, manual input module 54, which includes direction control unit 55, outputs direction control signal S_{CNT} . Communication module 53 connects to manual input module 54 and transmits second target motion signal S_{TAR2} according to the direction control

signal to control the motion of remote-controlled device 4. *Id.* at col. 6, ll. 8–15.

In the third operation mode, communication module 53 transmits third target motion signal S_{TAR3} according to the acceleration sensing signal and the direction control signal to control the motion of remote-controlled device 4. *Id.* at col. 6, ll. 19–25.

Remote controller 5 includes configuration switch module 52. The configuration switch module selects the mode of operation by selecting acceleration sensing module 51 and/or manual input module 54 as the input for communication module 53. *Id.* at col. 6, ll. 32–36.

C. Illustrative Claim

Claim 1, the sole independent claim, is illustrative and reproduced below.

1. A remote control system, comprising:
 - a remote controller, comprising:
 - a first acceleration sensing module, which detects the remote controller's motion and outputs a motion detecting signal;
 - a manual input module, which has at least one direction control unit to generate a direction control signal;
 - a first communication module, which connects to the first acceleration sensing module and the manual input module, the first communication module receives the motion detecting signal and the direction control signal, and transmits a target motion signal; and

a configuration switch module to select between the first acceleration sensing module, the manual input module and the combination of the first acceleration sensing module and the manual input module as the input of the first communication module; and

a remote-controlled device, which is controlled by the remote controller, comprising:

a second communication module, which receives the target motion signal from the remote controller;

a second acceleration sensing module, which detects the remote-controlled device's acceleration and outputs an acceleration sensing signal;

a processing module, which has a first input connected to the second acceleration sensing module and receives the acceleration sensing signal, and a second input connected to the second communication module and receives the target motion signal, and processes the acceleration sensing signal and the target motion signal to output a driving control signal; and

a driving module, which connects to the processing module and receives the driving control signal, and adjusts the remote-controlled device's motion according to the driving control signal.

Explore Litigation Insights

Docket Alarm provides insights to develop a more informed litigation strategy and the peace of mind of knowing you're on top of things.

Real-Time Litigation Alerts



Keep your litigation team up-to-date with **real-time alerts** and advanced team management tools built for the enterprise, all while greatly reducing PACER spend.

Our comprehensive service means we can handle Federal, State, and Administrative courts across the country.

Advanced Docket Research



With over 230 million records, Docket Alarm's cloud-native docket research platform finds what other services can't. Coverage includes Federal, State, plus PTAB, TTAB, ITC and NLRB decisions, all in one place.

Identify arguments that have been successful in the past with full text, pinpoint searching. Link to case law cited within any court document via Fastcase.

Analytics At Your Fingertips



Learn what happened the last time a particular judge, opposing counsel or company faced cases similar to yours.

Advanced out-of-the-box PTAB and TTAB analytics are always at your fingertips.

API

Docket Alarm offers a powerful API (application programming interface) to developers that want to integrate case filings into their apps.

LAW FIRMS

Build custom dashboards for your attorneys and clients with live data direct from the court.

Automate many repetitive legal tasks like conflict checks, document management, and marketing.

FINANCIAL INSTITUTIONS

Litigation and bankruptcy checks for companies and debtors.

E-DISCOVERY AND LEGAL VENDORS

Sync your system to PACER to automate legal marketing.