

(19) World Intellectual Property
Organization
International Bureau



(43) International Publication Date
11 November 2004 (11.11.2004)

PCT

(10) International Publication Number
WO 2004/097520 A2

(51) International Patent Classification⁷: **G03F**

14526 (US). **NEES, John** [US/US]; 2520 Victoria, Ann Arbor, MI 48104 (US). **HOU, Bixue** [CN/US]; 1666 Cram Circle #3, Ann Arbor, MI 48104 (US).

(21) International Application Number:
PCT/US2004/012714

(74) Agent: **FORBIS, Glenn, E.**; Rader, Fishman & Grauer PLLC, 39533 Woodward Avenue, Suite 140, Bloomfield Hills, MI 48304 (US).

(22) International Filing Date: 26 April 2004 (26.04.2004)

(25) Filing Language: English

(81) Designated States (unless otherwise indicated, for every kind of national protection available): AE, AG, AL, AM, AT, AU, AZ, BA, BB, BG, BR, BW, BY, BZ, CA, CH, CN, CO, CR, CU, CZ, DE, DK, DM, DZ, EC, EE, EG, ES, FI, GB, GD, GE, GH, GM, HR, HU, ID, IL, IN, IS, JP, KE, KG, KP, KR, KZ, LC, LK, LR, LS, LT, LU, LV, MA, MD, MG, MK, MN, MW, MX, MZ, NA, NI, NO, NZ, OM, PG, PH, PL, PT, RO, RU, SC, SD, SE, SG, SK, SL, SY, TJ, TM, TN, TR, TT, TZ, UA, UG, US, UZ, VC, VN, YU, ZA, ZM, ZW.

(26) Publication Language: English

(30) Priority Data:
60/465,062 24 April 2003 (24.04.2003) US

(71) Applicant (for all designated States except US): **THE REGENTS OF THE UNIVERSITY OF MICHIGAN** [US/US]; Wolverine Tower, Room 2071, 3003 S. State Street, Ann Arbor, MI 48109 (US).

(72) Inventors; and

(75) Inventors/Applicants (for US only): **MOUROU, Gerard, A.** [US/US]; 4151 Thornoaks Dr., Ann Arbor, MI 48104 (US). **GALVANAUSKAS, Almantas** [LT/US]; 4963 Ravine Ct., Ann Arbor, MI 48104 (US). **THEOBALD, Wolfgang** [DE/US]; 16, Pond Valley Circle, Penfield, NY

(84) Designated States (unless otherwise indicated, for every kind of regional protection available): ARIPO (BW, GH, GM, KE, LS, MW, MZ, NA, SD, SL, SZ, TZ, UG, ZM, ZW), Eurasian (AM, AZ, BY, KG, KZ, MD, RU, TJ, TM), European (AT, BE, BG, CH, CY, CZ, DE, DK, EE, ES, FI, FR, GB, GR, HU, IE, IT, LU, MC, NL, PL, PT, RO, SE, SI, SK, TR), OAPI (BF, BJ, CF, CG, CI, CM, GA, GN, GQ, GW, ML, MR, NE, SN, TD, TG).

[Continued on next page]

(54) Title: FIBER LASER-BASED EUV-LITHOGRAPHY

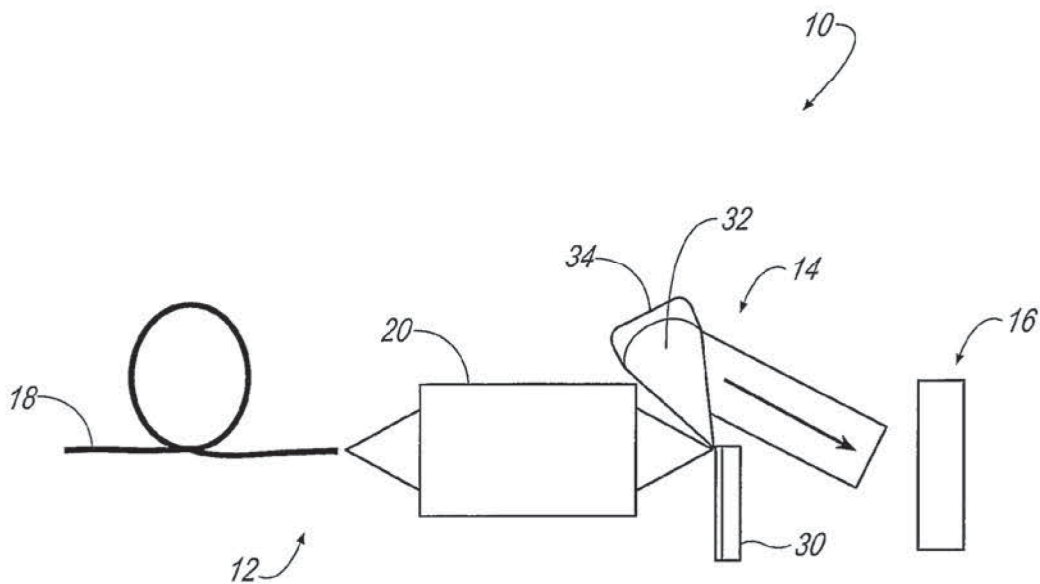

(57) Abstract: A method and apparatus is disclosed for performing lithography operation. A fiber laser (18) is provided that generates laser light that is used by adaptive optics (20) to focus the laser light onto a plasma target (30) to generate plasma as a source of EUV radiation.

WO 2004/097520 A2

**Declarations under Rule 4.17:**

- as to applicant's entitlement to apply for and be granted a patent (Rule 4.17(ii)) for the following designations AE, AG, AL, AM, AT, AU, AZ, BA, BB, BG, BR, BW, BY, BZ, CA, CH, CN, CO, CR, CU, CZ, DE, DK, DM, DZ, EC, EE, EG, ES, FI, GB, GD, GE, GH, GM, HR, HU, ID, IL, IN, IS, JP, KE, KG, KP, KR, KZ, LC, LK, LR, LS, LT, LU, LV, MA, MD, MG, MK, MN, MW, MX, MZ, NA, NI, NO, NZ, OM, PG, PH, PL, PT, RO, RU, SC, SD, SE, SG, SK, SL, SY, TJ, TM, TN, TR, TT, TZ, UA, UG, UZ, VC, VN, YU, ZA, ZM, ZW, ARIPO patent (BW, GH, GM, KE, LS, MW, MZ, NA, SD, SL, SZ, TZ, UG, ZM, ZW), Eurasian patent (AM, AZ, BY, KG, KZ, MD, RU, TJ, TM), European patent (AT, BE, BG, CH, CY, CZ, DE, DK, EE, ES, FI, FR, GB, GR, HU, IE, IT, LU, MC, NL, PL, PT, RO, SE, SI, SK, TR), OAPI patent (BF, BJ, CF, CG, CI, CM, GA, GN, GQ, GW, ML, MR, NE, SN, TD, TG)
- as to the applicant's entitlement to claim the priority of the earlier application (Rule 4.17(iii)) for the following designations AE, AG, AL, AM, AT, AU, AZ, BA, BB, BG, BR, BW, BY, BZ, CA, CH, CN, CO, CR, CU, CZ, DE, DK, DM, DZ,

EC, EE, EG, ES, FI, GB, GD, GE, GH, GM, HR, HU, ID, IL, IN, IS, JP, KE, KG, KP, KR, KZ, LC, LK, LR, LS, LT, LU, LV, MA, MD, MG, MK, MN, MW, MX, MZ, NA, NI, NO, NZ, OM, PG, PH, PL, PT, RO, RU, SC, SD, SE, SG, SK, SL, SY, TJ, TM, TN, TR, TT, TZ, UA, UG, UZ, VC, VN, YU, ZA, ZM, ZW, ARIPO patent (BW, GH, GM, KE, LS, MW, MZ, NA, SD, SL, SZ, TZ, UG, ZM, ZW), Eurasian patent (AM, AZ, BY, KG, KZ, MD, RU, TJ, TM), European patent (AT, BE, BG, CH, CY, CZ, DE, DK, EE, ES, FI, FR, GB, GR, HU, IE, IT, LU, MC, NL, PL, PT, RO, SE, SI, SK, TR), OAPI patent (BF, BJ, CF, CG, CI, CM, GA, GN, GQ, GW, ML, MR, NE, SN, TD, TG)

- of inventorship (Rule 4.17(iv)) for US only

Published:

- without international search report and to be republished upon receipt of that report

For two-letter codes and other abbreviations, refer to the "Guidance Notes on Codes and Abbreviations" appearing at the beginning of each regular issue of the PCT Gazette.

FIBER LASER - BASED EUV-LITHOGRAPHY

BACKGROUND

[0001] Lithography is a process used in semiconductor fabrication. In order to continue semiconductor integrated circuit speed increase at the rate predicted by the Moore's Law, which states that the circuit density of microchips doubles every 18 months, the limits of optical lithography must be expanded. To meet this prediction, the manufacturing of next generation electronic devices will demand lithography light sources having wavelengths with high power and high-frequency, otherwise known as EUV (extreme ultraviolet). However, producing radiation at such high power and frequencies is technologically very difficult and, although some sources of EUV radiation do exist, none of these systems are currently adequate for practical use in industrial EUV lithography.

[0002] One way to produce EUV radiation having such desired characteristics is by generating laser-produced plasma and then using the radiation from the plasma to perform the lithography process. In such a method, a pulsed laser beam is focused on a plasma target having the requisite material for producing plasma. The laser-matter interaction, resulting from the targeted laser pulse on the material, leads to the formation of hot plasma. The formation of such hot plasma serves as a source of EUV radiation for the lithography process.

[0003] Typically, such EUV generation requires very high laser light peak intensities on the target, thus necessitating the use of large and complex laser systems capable of producing high energy pulses at high average power. This also presents a further problem that it is essential that laser sources are sufficiently compact, robust and affordable for productive industrial use. The present invention was developed in light of these and other drawbacks.

BRIEF DESCRIPTION OF THE DRAWINGS

[0004] Figure 1 is a schematic view of a lithography device according to an embodiment of the invention;

[0005] Figure 2 is a schematic view of a lithography device according to an embodiment; and

[0006] Figure 3 is a schematic view of a lithography device according to an embodiment.

DETAILED DESCRIPTION OF AN EMBODIMENT

[0007] A method and apparatus for EUV lithography provides a high EUV radiation source having a lower power consumption by the laser and a reduced amount of debris generated by the plasma target. As a result, this radiation source does not require a large complex laser or a high-energy supply to the laser. The method and apparatus includes an improved laser source that uses fiber lasers in combination with adaptive optics. In addition, the method and apparatus allows for minimal debris generation as the overall power and target size is reduced from that of the conventional art.

[0008] Further, the present invention uses a pulsed high-power fiber laser configuration which uses optimum-duration pulses to further enhance the generation of EUV radiation. Additionally, to utilize the enhanced wave front characteristics of laser light from the fiber laser configuration to achieve the desired spot size on the plasma target, the present invention includes adaptive optics which enable the laser light to be focused into a small diffraction-limited spot on the plasma target with an improved energy concentration, thus reducing energy requirements by the laser, minimizing the needed volume of the plasma target and substantially reducing the amount of laser-produced debris.

[0009] Referring now to Figure 1, an embodiment of the present invention is shown and described. In Figure 1, an optical lithography system 10 is shown including optics 12, plasma portion 14, and lithography target 16. The optics 12 generally includes a fiber laser 18 and adaptive optics 20. As will be readily understood by one skilled in the art, fiber lasers, such as fiber laser 18, use optical fiber to culminate laser light to its diffraction limit while maintaining wave front control. As will be readily understood by one skilled in the art, fiber lasers use optical fiber to produce high quality optical beam (diffraction limited beam) which can be focused into a diffraction limited spot of minimum size, compared to the optical wavelength, by using wave front control. Wave front control ensures that all the beam distortions acquired during beam generation and transmission to the target are compensated for. More specifically, the fiber laser 18, as opposed to conventional solid state laser configurations, maximizes the organization of light at a given energy level to allow it to be focused on a relatively small area. Preferably, fiber laser 18 includes a high

gain fiber amplifier, which allows for the production of laser pulses with pulse durations in the 1-ps to 1-ns duration range for reasons that will be described in greater detail. Also preferably, fiber laser 18 uses a diode-laser source, which enables enhanced control over the temporal profile of the laser pulse as will also be described in greater detail.

[00010] The adaptive optics 20, as will be readily understood by one skilled in the art, is a series of optical components including lenses mirrors and other known optical devices that adapt or change to achieve the desired image sharpness or image size. The adaptive optics includes deformable mirrors and high NA (numerical aperture) optics that allows enhanced control over the focusing of laser light generated by fiber laser 18. The adaptive optics will be described in greater detail below.

[00011] The plasma portion 14 generally includes a plasma target 30, plasma 32 and focusing element 34. The plasma target 30 is constructed of a material that generates plasma 32 upon sufficient laser energy being transmitted to the plasma target 30 by optics 12. The plasma 32 emits EUV radiation that is used for conducting lithography operations on lithography target 16. The focusing element 34 focuses the resulting EUV radiation on the lithography target 16.

[00012] The adaptive optics 20 serves to reduce the focused spot size on the plasma target 30 relative to that achievable with standard optics. Reduction of the focused spot size on the plasma target 30 reduces the amount of energy needed to be supplied to the fiber laser 18 to generate the desired plasma with the desired EUV radiation. Specifically, the pulse energy E_{pulse} provided by the laser and the fluence F , or flux of photons, of a beam are related through the beam cross-section area A . Specifically, $E_{\text{pulse}} = AF$. A is the cross-sectional area of a beam at any point and F is the fluence at that same point along the beam. Therefore:

$$A_L F_L \cong A_T F_T$$

[00013] Where $A_L F_L$ is the cross-sectional area of the laser beam at the laser multiplied by the fluence F_L of the laser light at the laser and $A_T F_T$ is the area of the laser beam at the plasma target 30 times the fluence F_T at the plasma target 30. The energy fluence on a plasma target 30 needed for generating plasma 32 with the desired EUV output is approximately $F_T \approx 1 \text{ kJ/cm}^2$. Therefore, the required fluence at the laser is determined by the ratio between the areas of the focused spot on the plasma target and the beam in the fiber of the fiber laser 18: $F_L \cong (A_T / A_L) F_T$. For light at $\sim 1\text{-}\mu\text{m}$ wavelengths,

the diffraction-limited spot size on a plasma target 30 attainable with compensated high-NA (numerical aperture) adaptive optics is $\sim 1\text{-}\mu\text{m}$ in diameter. Therefore, achievable 10 to 30- μm diameter beams in fiber lasers use fiber fluencies of approximately 100 to 1000 times lower than on the plasma target (approximately $1 - 10 \text{ J/cm}^2$), which is significantly below the current approximate $\sim 50 \text{ J/cm}^2$ limit in fiber lasers. As such, use of fiber technology allows greater than 10kW average power to be distributed to the target with diffraction-limited beam quality, which generates the needed 100 W of power on the plasma target 30 with a diameter of 13.5nm for generating plasma 32.

[00014] The adaptive optics 12 focuses a spot on plasma target 30 limited by the wavelength of the light with a Strehl ratio close to 1. The Strehl ratio defines how small the spot focused on the plasma target 30 can be as a function limited by the wavelength of the projected light. As can be seen, such a condition demands a well corrected wave front, which is generally provided through use of fiber lasers. For small wave front variations, the Strehl ratio is given by the Maréchal expression, which is:

$$I(P) \approx 1 - \left(\frac{2\pi}{\lambda} \right)^2 (\Delta\Phi)^2$$

where λ is the wavelength of the laser light,

$(\Delta\Phi)^2$ is the root-mean-square deviation from the ideal wavefront.

[00015] Therefore, to obtain 80% of the light projected by optics 12 into the desired focal spot on the plasma target 30, as described above, the wavefront must be corrected by $\lambda/14$. For 50% of the light to be projected into the desired focal spot, the correction must be greater than $\lambda/8$. This type of wavefront quality is obtainable by using adaptive optics such as those including deformable mirrors.

[00016] The plasma target 30 is constructed of a material type that preferably reduces the amount of solid debris that results from generation of plasma 32. Such solid debris constitutes solid particles other than the plasma 32 which may cause damage to optical components in the system. A reduced debris laser, or a "clean" source, is where plasma particle emission is below a level that would otherwise cause damage or degradation of the optics. Preferably, mass limited targets are used as plasma target 30. Such targets may include solid films, liquids and gaseous targets. A mass limited target

limits the amount of produced debris, as the target contains less mass from which solid particles may be formed that interfere with the optical components of optics 12. In an embodiment, xenon or another noble element is used to realize high EUV emissions and clean operation. Plasma target 30 may be provided in the optical path of the fiber laser 18 by a liquid rare gas jet or a fast spinning disc covered with a cryogenically cooled rare gas-film such as a xenon film.

[00017] In another embodiment, as shown in figure 3, shielding 50 is provided over the optics 12. Shielding 50 may take the form of a film of material with high transmission, but which stops the debris from hitting the optics 12. The film is preferably constantly refreshed to avoid accumulation of ablated material on the shielding film. Shielding 50 may also be an electrostatic capacitor or a magnetic field to deflect charged plasma particles away from the optics 12. Additionally, plasma portion 14 may include a chamber 52 which maintains the environment with a low pressure inert gas.

[00018] In one example, a spot size of $1\mu\text{m}$ is generated on plasma target 30. Here, plasma target 30 is a spinning disc. The spot is displaced at least twice the focus size ($2\mu\text{m}$) from the center of the plasma target 30. The plasma target 30 has a rotation rate of 3Mhz and a target velocity of $\sim 6\text{m/s}$. With a disc radius of 10cm and a rotation of the disc with ~ 100 revolutions per second, the target lasts for approximately 15 minutes. A film thickness of at least 3 times the confocal parameter of the focusing optics is therefore used to retain the overall thickness of the plasma target 30.

[00019] As shown in Figure 2, scaling of power may be achieved by combining the outputs of multiple fibers. Specifically, fiber laser 18 is shown having a plurality of fibers 26 that feed into a combining device 28. The combining device 28 may be any known combining device for combining a plurality of optical outputs. The output of the combining device 28 is then fed into adaptive optics 20 (see Figure 1). As mode properties of fiber lasers are fixed by the fiber core structure, it is possible to maintain strong single-mode operation even at very high output powers by using this multiple fiber approach. Combining device 28 may either use coherent or incoherent combining methods, which will be understood by one skilled in the art. In the case of coherent combining, nearly diffraction-limited spot sizes can be maintained for a multi-fiber structure. Conversely, incoherent combining would result in larger focused spot sizes on the target, which can be compensated by the increase in the overall output energy by combining the output from

several fibers 26. In this case, energy requirements for each individual fiber 26 can remain low.

[00020] In addition, pulse shaping can be used to further enhance EUV efficiency. By EUV efficiency, the amount of energy supplied to the fiber laser 18 is compared with the amount of energy or EUV radiation generated from the plasma 32. The use of fiber lasers enhances EUV efficiency by pulse shaping and the implementation of pre-pulses, in order to tailor the plasma conditions of the plasma 32 for the highest laser energy. Specifically, more precise control provided by virtue of a more organized light source allows better control of the energy supplied by a given pulse. As such, the laser pulses can be specifically tailored to provide a specific amount of energy to create a specific amount of plasma. Likewise, pre-pulses may be used to assist in generating the requisite amount of plasma required for the given task.

[00021] The efficiency of laser-to-EUV light conversion is a function of optical pulse duration and on the use of pre-pulses. Overall, this dependence is affected by a number of factors, such as laser wavelength, pre-pulse delay, pre-pulse energy, target material and geometry. However, the preferable pulse duration for a given material ranges from ~1ps to <1ns for EUV generation. Use of such preferable duration pulses leads to a significant increase in laser-to-EUV conversion efficiency compared to non-optimum duration pulses. As a result, the amount of EUV energy per unit of energy supplied to the laser is maximized when pulses in this range are used.

[00022] In one example, water is used as the plasma target 30. In this example, conversion efficiencies of laser energy into 13.5nm radiation energy are obtained from water droplet targets at various pulse durations using a Ti:sapphire laser at 800nm. The optimum pulse duration is ~120ps with an efficiency of 0.2% for a pulse energy of 50mJ, and the efficiency is reduced by a factor of two for a pulse duration of 6ns.

[00023] In another example, xenon cluster targets are used as plasma target 30. Plasma target 30 exhibits a continuous decrease in efficiency with longer pulse duration. Starting with an efficiency of about 0.2% for 1ps pulse duration generated with 3.5mJ Ti:sapphire laser pulses, the EUV efficiency drops by almost three times in magnitude for a 10ns pulse duration and approximately 50mJ pulse energy. Applying 1.7kW Q-switched Nd:YAG lasers with pulse energies of about 1J, state-of-the-art EUV sources with liquid xenon spray targets yield efficiencies of about 0.6%. With the implementation of pre-

pulses, the EUV efficiency increases by a factor of 15. A pre-pulse is a specifically shaped part of the pulse having a lower amplitude compared to the pulse energy peak, which precedes the energy peak in time. A pre-pulse modified target material prior to the arrival of the main energy peak in such a way as to facilitate EUV light production from plasma generated at the main laser pulse energy peak.

[00024] For pulses of greater than 50ps duration, the required energies can be amplified in the fiber laser 18 directly, while pulses of less than 50ps duration can be obtained through the additional use of chirped pulse amplification arrangements as will readily be understood by one skilled in the art. The high spatial quality obtainable from high-power fiber lasers allows focusing of the energy over a small focal Rayleigh volume of few λ^3 (cubic wavelengths). Because of how relatively small the focal volume of the plasma target 30 is, plasma target 30 is preferably solid or liquid.

CLAIMS

1. A system for performing lithography operations, comprising:
a fiber laser (18); and
adaptive optics (20) adapted to receive light from the fiber laser (18) and focus it on a target.
2. The system according to claim 1, wherein:
the target (30) is a plasma target (30); and
the plasma target (30) is adapted to generate plasma when light from the adaptive optics (20) having desired characteristics is directed on a spot on the plasma target (30).
3. The system according to claim 2, wherein the characteristics include a fluence of about $1\text{kJ}/\text{cm}^2$.
4. The system according to claim 3, wherein at least one fiber of the fiber laser (18) exhibits a fluence of less than $10\text{ J}/\text{cm}^2$.
5. The system according to claim 4, wherein a size of the spot is about $1\text{-}\mu\text{m}$.
6. The system according to claim 5, wherein the adaptive optics (20) includes deformable mirrors.
7. The system according to claim 1, wherein the fiber laser (18) comprises a plurality of fibers.
8. The system according to claim 7, further comprising a combining device (34).
9. The system according to claim 8, wherein the system is adapted to combine outputs of each of the plurality of fibers to increase an output power from the adaptive optics (20).
10. The system according to claim 9, wherein the combining device (34) is adapted to combine the outputs of each of the fibers by either coherent or incoherent methods.

11. The system according to claim 2, wherein the plasma target (30) is xenon.
12. The system according to claim 11, wherein the fiber laser (18) is adapted to generate light on the plasma target (30) at a pulse duration of 1ps and a pulse energy of 1J.
13. The system according to claim 12, wherein the plasma target (30) is liquid xenon spray.
14. The system according to claim 13, wherein the laser is adapted to implement pre-pulses of light on the plasma target (30).
15. The system according to claim 2, wherein the fiber laser (18) is adapted to generate light at a pulse duration of between about 1ps to 1ns.
16. The system according to claim 2, further comprising:
 - a lithography target (16); and
 - a focusing element that focuses EUV radiation from plasma generated from the plasma target (30) onto the lithography target (16).
17. A method for generating EUV radiation, comprising:
 - providing a plasma target (30);
 - generating laser light with a fiber laser (18); and
 - focusing the laser light on the plasma target (30) with adaptive optics (20).
18. The method according to claim 17, wherein the plasma target (30) is xenon.
19. The method according to claim 17, further comprising the step of generating the laser light on the plasma target (30) and a pulse duration of 1ps and a pulse energy of 1J.
20. The method according to claim 17, wherein the plasma target (30) is liquid xenon spray.
21. The method according to claim 20, wherein the laser is adapted to implement pre-pulses of light on the plasma target (30).

22. The method according to claim 17, further comprising the step of generating light at a pulse duration of between about 1ps to 1ns.

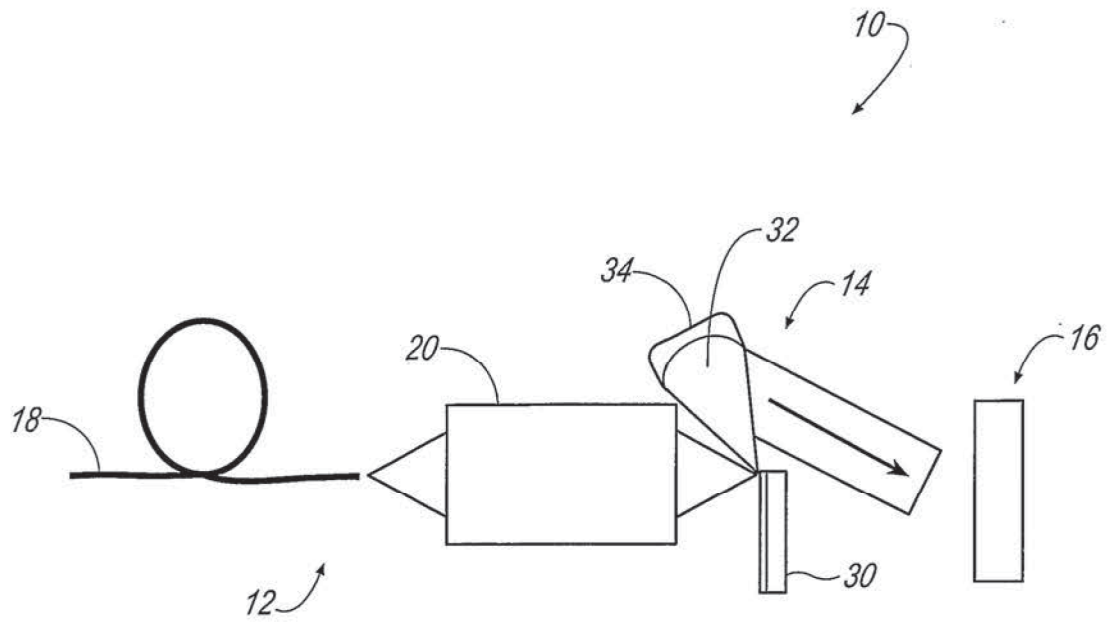

FIG. 1

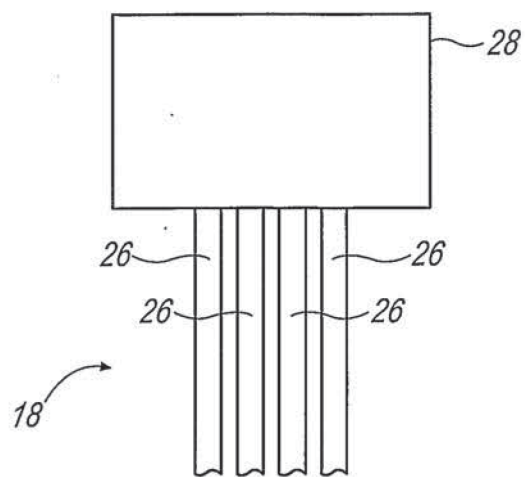

FIG. 2

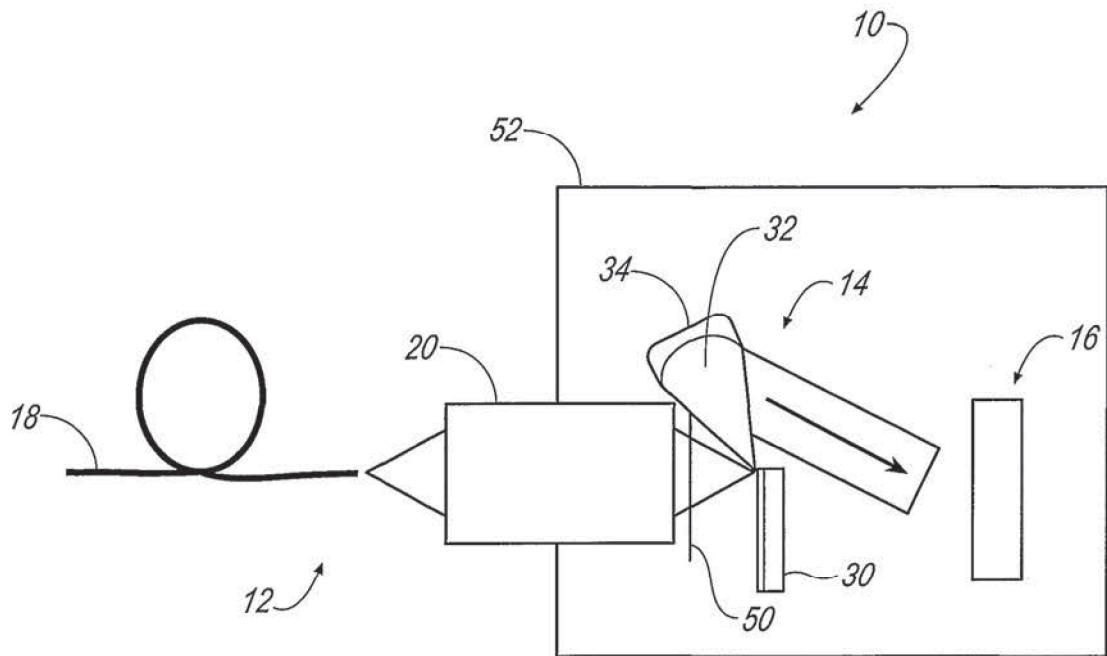

FIG. 3