



US006746471B2

(12) **United States Patent**  
**Mortier et al.**

(10) **Patent No.:** **US 6,746,471 B2**  
(45) **Date of Patent:** **Jun. 8, 2004**

(54) **TRANSVENTRICULAR IMPLANT TOOLS AND DEVICES**

4,536,893 A 8/1985 Parravicini  
4,690,134 A 9/1987 Snyders  
4,936,857 A 6/1990 Kulik

(75) Inventors: **Todd J. Mortier**, Minneapolis, MN (US); **Cyril J. Schweich, Jr.**, St. Paul, MN (US); **Robert M. Vidlund**, Maplewood, MN (US); **Peter T. Keith**, St. Paul, MN (US); **Thomas M. Paulson**, Minneapolis, MN (US); **David A. Kusz**, Minneapolis, MN (US)

(List continued on next page.)

**FOREIGN PATENT DOCUMENTS**

DE 296 19 294 8/1987  
DE 36 14 292 11/1987  
DE 42 34 127 5/1994  
DE 199 47 885 A1 4/2000  
DE 298 24 917 U1 6/2000

(List continued on next page.)

**OTHER PUBLICATIONS**

US 6,197,052, 3/2001, Cosgrove et al. (withdrawn)  
Kay et al., "Surgical Treatment of Mitral Insufficiency," *The Journal of Thoracic Surgery*, 29: 618-620, 1995.  
Harken et al., "The Surgical Correction of Mitral Insufficiency," *The Journal of Thoracic Surgery*, 28:604-627, 1954.  
Bailey et al., "Closed Intracardiac Tactile Surgery," *Diseases of the Chest*, XXII:1-24, Jul. 1952.

(List continued on next page.)

*Primary Examiner*—Julian W. Woo

(74) *Attorney, Agent, or Firm*—Finnegan, Henderson, Farabow, Garrett & Dunner, LLP

(57) **ABSTRACT**

A method and implantation tools for placing a transventricular splint including a tension member. The method includes gaining access to the patient's hearts and identifying entry or exit points for the tension member, marking those locations and delivering the tension member. Anchors for the tension member are also delivered. The length of the tensions member is measured and the walls of the heart drawn together. The pads are secured to the tension member and the tension member is trimmed to length. The pads are secured to the heart surface.

**22 Claims, 31 Drawing Sheets**

(73) Assignee: **Myocor, Inc.**, St. Paul, MN (US)

(\* ) Notice: Subject to any disclaimer, the term of this patent is extended or adjusted under 35 U.S.C. 154(b) by 306 days.

(21) Appl. No.: **09/864,320**

(22) Filed: **May 25, 2001**

(65) **Prior Publication Data**

US 2001/0025171 A1 Sep. 27, 2001

**Related U.S. Application Data**

(63) Continuation of application No. 09/123,977, filed on Jul. 29, 1998, now Pat. No. 6,260,552.

(51) **Int. Cl.**<sup>7</sup> ..... **A61B 17/28**

(52) **U.S. Cl.** ..... **606/207; 606/206; 600/201**

(58) **Field of Search** ..... 606/205-207,  
606/210, 211, 174; 600/210, 211, 16, 37,  
201, 231

(56) **References Cited**

**U.S. PATENT DOCUMENTS**

3,019,790 A \* 2/1962 Militana ..... 606/205  
3,980,086 A \* 9/1976 Kletschka et al. .... 606/174  
4,192,293 A 3/1980 Asrican  
4,261,342 A 4/1981 Aranguren Duo  
4,300,564 A \* 11/1981 Furihata ..... 606/207  
4,372,293 A 2/1983 Vijil-Rosales  
4,409,974 A 10/1983 Freedland

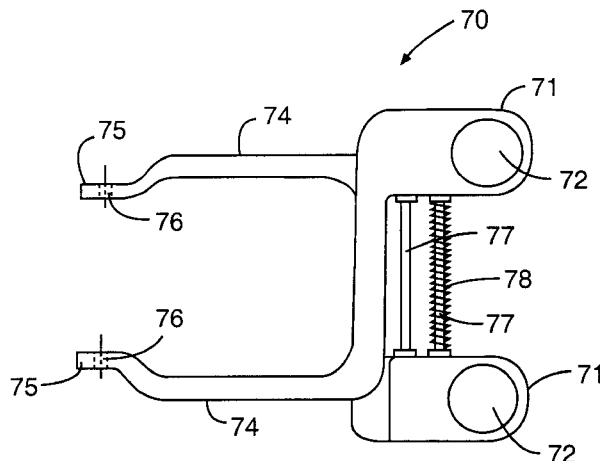

## U.S. PATENT DOCUMENTS

4,944,753 A	7/1990	Burgess et al.	6,125,852 A	10/2000	Stevens et al.
4,960,424 A	10/1990	Grooters	6,126,590 A	10/2000	Alferness
4,997,431 A	3/1991	Isner et al.	6,132,438 A	10/2000	Fleischman et al.
5,104,407 A	4/1992	Lam et al.	6,143,025 A	11/2000	Stobie et al.
5,106,386 A	4/1992	Isner et al.	6,155,968 A	12/2000	Wilk
5,131,905 A	7/1992	Grooters	6,155,972 A	12/2000	Nauertz et al.
RE34,021 E	8/1992	Mueller et al.	6,162,168 A	12/2000	Schweich, Jr. et al.
5,169,381 A	12/1992	Snyders	6,165,119 A	12/2000	Schweich, Jr. et al.
5,192,314 A	3/1993	Daskalakis	6,165,120 A	12/2000	Schweich, Jr. et al.
5,250,049 A	10/1993	Michael	6,165,121 A	12/2000	Alferness
5,284,488 A	2/1994	Sideris	6,165,122 A	12/2000	Alferness
5,300,087 A	* 4/1994	Knoepfler ..... 606/207	6,165,183 A	12/2000	Kuehn et al.
5,360,444 A	11/1994	Kusuhara	6,169,922 B1	1/2001	Alferness et al.
5,385,528 A	1/1995	Wilk	6,174,279 B1	1/2001	Girard
5,417,709 A	* 5/1995	Slater ..... 606/205	6,179,791 B1	1/2001	Krueger
5,433,727 A	7/1995	Sideris	6,182,664 B1	2/2001	Cosgrove
5,450,860 A	9/1995	O'Connor	6,190,408 B1	2/2001	Melvin
5,452,733 A	9/1995	Sterman et al.	6,193,648 B1	2/2001	Krueger
5,458,574 A	10/1995	Machold et al.	6,197,053 B1	3/2001	Cosgrove et al.
5,496,305 A	3/1996	Kittrell et al.	6,206,820 B1	3/2001	Kazi et al.
5,509,428 A	4/1996	Dunlop	6,217,610 B1	4/2001	Carpentier et al.
5,533,958 A	7/1996	Wilk	6,221,013 B1	4/2001	Panescu et al.
5,571,215 A	11/1996	Sterman et al.	6,221,103 B1	4/2001	Melvin
5,584,803 A	12/1996	Stevens et al.	6,221,104 B1	4/2001	Buckberg et al.
5,593,424 A	1/1997	Northrup III	6,224,540 B1	5/2001	Lederman et al.
5,665,092 A	9/1997	Mangiardi et al.	6,230,714 B1	5/2001	Alferness et al.
5,682,906 A	11/1997	Sterman et al.	6,238,334 B1	5/2001	Easterbrook, III et al.
5,702,343 A	12/1997	Alferness	6,241,654 B1	6/2001	Alferness
5,713,954 A	2/1998	Rosenberg et al.	6,245,102 B1	6/2001	Jayaraman
5,718,725 A	2/1998	Sterman et al.	6,245,105 B1	6/2001	Nguyen et al.
5,755,783 A	5/1998	Stobie et al.	6,250,308 B1	6/2001	Cox
5,800,334 A	9/1998	Wilk	6,258,021 B1	7/2001	Wilk
5,800,528 A	9/1998	Lederman et al.	6,261,222 B1	7/2001	Schweich, Jr. et al.
5,800,531 A	9/1998	Cosgrove et al.	6,264,602 B1	7/2001	Mortier et al.
5,814,097 A	9/1998	Sterman et al.	6,269,819 B1	8/2001	Oz et al.
5,849,005 A	12/1998	Garrison et al.	6,283,993 B1	9/2001	Cosgrove et al.
5,855,601 A	1/1999	Bessler et al.	6,314,322 B1	11/2001	Rosenberg
5,855,614 A	1/1999	Stevens et al.	6,332,863 B1	12/2001	Schweich, Jr. et al.
5,865,791 A	2/1999	Wayne et al.	6,332,864 B1	12/2001	Schweich, Jr. et al.
5,902,229 A	5/1999	Tsitlik et al.	6,332,893 B1	12/2001	Mortier et al.
5,928,281 A	7/1999	Huynh et al.	6,338,712 B2 *	1/2002	Spence et al. .... 600/201
5,944,738 A	8/1999	Amplatz et al.	6,375,608 B1	4/2002	Alferness
5,957,977 A	9/1999	Melvin	6,379,366 B1	4/2002	Fleischman et al.
5,961,440 A	10/1999	Schweich, Jr. et al.	6,402,680 B2	6/2002	Mortier et al.
5,961,549 A	10/1999	Nguyen et al.	6,406,420 B1	6/2002	McCarthy et al.
5,971,910 A	10/1999	Tsitlik et al.	6,409,760 B1	6/2002	Melvin
5,971,911 A	10/1999	Wilk	6,416,459 B1	7/2002	Haindl
5,972,022 A	10/1999	Huxel	6,439,237 B1	8/2002	Buckberg et al.
5,972,030 A	10/1999	Garrison et al.	6,450,171 B1	9/2002	Buckberg et al.
5,984,857 A	11/1999	Buck et al.	6,461,366 B1	10/2002	Seguin
5,984,917 A	11/1999	Fleischman et al.	6,494,825 B1	12/2002	Talpade
6,001,126 A	12/1999	Nguyen-Thien-Nhon	6,508,756 B1	1/2003	Kung et al.
6,019,722 A	* 2/2000	Spence et al. .... 600/37	6,514,194 B2	2/2003	Schweich, Jr. et al.
6,024,096 A	2/2000	Buckberg	6,520,904 B1	2/2003	Melvin
6,024,756 A	2/2000	Huebsch et al.	6,572,529 B2	6/2003	Wilk
6,045,497 A	4/2000	Schweich, Jr. et al.	6,589,160 B2	7/2003	Schweich, Jr. et al.
6,050,936 A	4/2000	Schweich, Jr. et al.	2001/0003986 A1	6/2001	Cosgrove
6,059,715 A	5/2000	Schweich, Jr. et al.	2001/0005787 A1	6/2001	Oz et al.
6,071,303 A	6/2000	Laufer	2001/0009976 A1	7/2001	Panescu et al.
6,077,214 A	6/2000	Mortier et al.	2001/0021874 A1	9/2001	Carpentier et al.
6,077,218 A	6/2000	Alferness	2001/0029314 A1	10/2001	Alferness et al.
6,079,414 A	6/2000	Roth	2002/0007216 A1	1/2002	Melvin
6,085,754 A	7/2000	Alferness et al.	2002/0022880 A1	2/2002	Melvin
6,086,532 A	7/2000	Panescu et al.	2002/0026092 A1	2/2002	Buckberg et al.
6,095,968 A	8/2000	Snyders	2002/0029783 A1	3/2002	Stevens et al.
6,102,944 A	8/2000	Huynh et al.	2002/0058855 A1	5/2002	Schweich, Jr. et al.
6,110,100 A	8/2000	Talpade	2002/0065465 A1	5/2002	Panescu et al.
6,113,536 A	* 9/2000	Aboul-Hosn et al. .... 600/231	2002/0091296 A1	7/2002	Alferness
6,117,159 A	9/2000	Huebsch et al.	2002/0111533 A1	8/2002	Melvin
			2002/0111636 A1	8/2002	Fleischman et al.

2002/0143250 A1 10/2002 Panescu et al.  
 2002/0161275 A1 10/2002 Schweich, Jr. et al.  
 2002/0169359 A1 11/2002 McCarthy et al.  
 2002/0173694 A1 11/2002 Mortier et al.  
 2003/0028077 A1 2/2003 Alferness et al.  
 2003/0032979 A1 2/2003 Mortier et al.  
 2003/0045771 A1 3/2003 Schweich, Jr. et al.

## FOREIGN PATENT DOCUMENTS

EP 0 583 012 2/1994  
 EP 0 820 729 A1 1/1998  
 WO 91/19465 12/1991  
 WO 95/06447 3/1995  
 WO 95/16476 6/1995  
 WO 96/04852 2/1996  
 WO 96/40356 12/1996  
 WO WO 97/14286 4/1997  
 WO WO 97/24082 7/1997  
 WO WO 97/24083 7/1997  
 WO 97/24101 7/1997  
 WO 98/03213 1/1998  
 WO 98/14136 4/1998  
 WO WO 98/17347 4/1998  
 WO 98/18393 5/1998  
 WO 98/26738 6/1998  
 WO 98/29041 7/1998  
 WO 98/32382 7/1998  
 WO WO 98/58598 12/1998  
 WO WO 99/00059 1/1999  
 WO 99/11201 3/1999  
 WO 99/13777 3/1999  
 WO WO 99/16350 4/1999  
 WO WO 99/22784 5/1999  
 WO WO 99/30647 6/1999  
 WO 99/30647 6/1999  
 WO 99/44534 9/1999  
 WO 99/44680 9/1999  
 WO WO 99/44969 9/1999  
 WO 99/52470 10/1999  
 WO WO 99/53977 10/1999  
 WO 99/56655 11/1999  
 WO WO 99/66969 12/1999  
 WO 00/02500 1/2000  
 WO WO 00/03759 1/2000  
 WO 00/06026 2/2000  
 WO 00/06028 2/2000  
 WO 00/13722 3/2000  
 WO 00/18320 4/2000  
 WO 00/27304 5/2000  
 WO 00/28912 5/2000  
 WO 00/28918 5/2000  
 WO 00/36995 6/2000  
 WO 00/42919 7/2000  
 WO 00/45735 8/2000  
 WO 00/61033 10/2000  
 WO 00/62727 10/2000  
 WO 01/03608 A1 1/2001  
 WO 01/21070 A1 3/2001  
 WO 01/21098 A1 3/2001  
 WO 01/21099 A1 3/2001  
 WO 01/50981 A1 7/2001

## OTHER PUBLICATIONS

Sakakibara, "A Surgical Approach to the Correction of Mitral Insufficiency," *Annals of Surgery*, 142:196–203, 1955.  
 Glenn et al., "The Surgical Treatment of Mitral Insufficiency: The Fate of A Vascularized Transchamber Intracardiac Graft," *Annals of Surgery*, 141:510–518, Apr. 1955.  
 Kay et al., "Surgical Treatment of Mitral Insufficiency,"

Bailey et al. "The Surgical Correction of Mitral Insufficiency By The Use of Pericardial Grafts," *The Journal of Thoracic Surgery*, 28:551–603, Dec. 1954.

Harken et al., "The Surgical Correction of Mitral Insufficiency," *Surgical Forum*, 4:4–7, 1953.

Shumacker, Jr., "Attempts to Control Mitral Regurgitation," *The Evolution of Cardiac Surgery*, 203–210, 1992.

Eddie, M.D. et al., "Surgical repair of single ventricle," *The Journal of Thoracic and Cardiovascular Surgery*, vol. 66, No. 3, Sep., 1973, pp. 350–360.

McGoon, M.D. et al., "Correction of the univentricular heart having two atrioventricular valves," *The Journal of Thoracic and Cardiovascular Surgery*, vol. 74, No. 2, Aug., 1977, pp. 218–226.

Lev, M.D., et al., "Single (Primitive) Ventricle," *Circulation*, vol. 39, May, 1969, pp. 577–591.

Westaby with Boshier, "Landmarks in Cardiac Surgery," 1997, p. 198–199.

Shumacker, "Cardiac Aneurysms," *The Evolution of Cardiac Surgery*, 1992, pp. 159–165.

Feldt, M.D., "Current status of the septation procedure for univentricular heart," *The Journal of Thoracic and Cardiovascular Surgery*, vol. 82, No. 1, Jul., 1981, pp. 93–97.

Doty, M.D., "Septation of the univentricular heart," *The Journal of Thoracic and Cardiovascular Surgery*, vol. 78, No. 3, Sep., 1979, pp. 423–430.

Carpentier et al., "Myocardial Substitution with a Stimulated Skeletal Muscle: First Successful Clinical Case," Letter to the Editor, p. 1267, Sep. 25, 1996.

Ianuzzo et al., "Preservation of the Latissimus Dorsi Muscle During Cardiomyoplasty Surgery," *J. Card. Surg.*, 1996:11:99–108.

Ianuzzo et al., "On Preconditioning of Skeletal Muscle: Application to Dynamic Cardiomyoplasty," Invited Commentary, *J. Card. Surg.*, 1996:11:109–110.

Chachques et al., "Latissimus Dorsi Dynamic Cardiomyoplasty," *Ann. Thorac. Surg.*, 1989:47:600–604.

Moreira et al., "Latissimus Dorsi Cardiomyoplasty in the Treatment of Patients with Dilated Cardiomyopathy," Supplement IV *Circulation*, Sep. 25, 1996, 7 pgs.

Lucas et al., "Long-Term Follow-Up (12 to 35 Weeks) After Dynamic Cardiomyoplasty," *JACC*, vol. 22, No. 3, Sep. 1993:758–67.

Batista et al., "Partial Left Ventriculectomy to Improve Left Ventricular Function in End-Stage Heart Disease," *J. Card. Surg.*, 1996:11:96–98.

"Congestive Heart Failure in the United States: A New Epidemic" Data Fact Sheet, National Heart, Lung, and Blood Institute, National Institutes of Health, Dec. 9, 1996, pp. 1–6.

Kormos et al., "Experience with Univentricular Support in Morally Ill Cardiac Transplant Candidates," *Ann. Thorac. Surg.*, 1990:49:261–71.

Wampler et al., "Treatment of Cardiogenic Shock with the Hemopump Left Ventricular Assist Device," *Ann. Thorac. Surg.*, 1991:52:506–13.

McCarthy et al., "Clinical Experience with the Novacor Ventricular Assist System," *J. Thorac. Cardiovasc. Surg.*,

- Burnett et al., "Improved Survival After Hemopump Insertion in Patients Experiencing Postcardiotomy Cardiogenic Shock During Cardiopulmonary Bypass," From the Section of Transplantation, Division of Cardiovascular Surgery, Texas Heart Institute and St. Luke's Episcopal Hospital, Houston, Texas, dated even with or prior to Jan. 2, 1997, pp. 626-628.
- Phillips et al., "Hemopump Support for the Failing Heart," From the Department of Cardiovascular Medicine and Surgery, Mercy Hospital Medical Center, Des Moines, Iowa, date even with or prior to Jan. 2, 1997, pp. 629-631.
- Deeb et al., "Clinical Experience with the Nimbus Pump," From the University of Michigan Medical Center Section of Thoracic Surgery and Division of Cardiology, Ann Arbor, Michigan, date even with or prior to Jan. 2, 1997, pp. 632-636.
- Bearnson et al., "Development of a Prototype Magnetically Suspended Rotor Ventricular Assist Device," *ASAIO Journal*, 1996, pp. 275-280.
- Sakakibara et al., "A Muscle Powdered Cardiac Assist Device for Right Ventricular Support: Total Assist or Partial Assist?," *Trans. Am. Soc. Artif. Intern. Organs*, vol. XXXVI, 1990, pp. 372-375.
- Medtronic, Inc. 1996 Annual Shareholders Report, 79 pages.
- Abiomed, Inc. Annual Report 1996, 32 pages.
- Press Release dated Sep. 16, 1996, "Abiomed Wins \$8.5 Million Federal Contract to Qualify its Artificial Heart for Human Trials," 5 pages.
- Press Release dated Sep. 26, 1996, "Abiomed's Temporary Artificial Heart System Reaches 200 U.S. Medical Center Milestone," 1 page.
- Press Release dated May 17, 1996, "Abiomed Receives FDA Approval to Expand Indications for Use of Cardiac Assist System," 1 page.
- Press Release dated Oct. 3, 1995, "Abiomed Wins \$4.35 Million Contract from the National Heart, Lung and Blood Institutes to Develop Implantable Heart Booster," 1 page.
- Press Release dated Sep. 29, 1995, "Abiomed Wins NIH Grant to Develop Calcification-Resistant Plastic Heart Valve," 1 page.
- Press Release dated Aug. 25, 1995, "Abiomed Wins Research Grant from NIH to Develop Suturing Instrument for Abdominal surgery," 1 page.
- Press Release dated Aug. 11, 1995, "Abiomed Receives Grant from NIH to Develop Disposable Bearingless Centrifugal Blood Pump," 1 page.
- Press Release dated Jun. 9, 1995, "Abiomed Receives Grant from National Institutes of Health to Develop a Laser Welding Technique for Tissue Repair," 1 page.
- Press Release dated Apr. 27, 1995, "Abiomed's Temporary Artificial Heart System Reaches 1,000 Patient Milestone; BVS-5000 in More Than 100 U.S. Medical Centers," 1 page.
- "Reversible Cardiomyopathy," *Thoratec's Heartbeat*, vol. 10.2, Aug. 1996, 4 pages.
- Tsai et al., "Surface Modifying Additives for Improved Device-Blood Compatibility," *ASAIO Journal*, 1994, pp. 619-624.
- Farrar et al., "A New Skeletal Muscle Linear-Pull Energy Converter as a Power Source for Prosthetic Support Devices," *The Journal of Heart & Lung Transplantation*, vol. 11, 1992, pp. 1002-1010.
- Brochure entitled "Thoratec Ventricular Assist Device System—Because Heart Patients Come in All Sizes," date even with or prior to Jan. 2, 1997, 5 pages.
- Press Release dated Oct. 3, 1994, "Heartmate System Becomes First Implantable Cardiac-Assist Device to be Approved for Commercial Sale in the U.S.," 2 pages.
- Bocchi et al., "Clinical Outcome after Surgical Resection of Left Ventricle in Candidates to Heart Transplantation with Idiopathic Dilated Cardiomyopathy—Short Term Results," date even with or prior to Jan. 2, 1997, 1 page.
- Bach et al., "Early Improvement in Congestive Heart Failure after Correction of Secondary Mitral Regurgitation in End-Stage Cardiomyopathy," *American Heart Journal*, Jun. 1995, pp. 1165-1170.
- Schuler et al., "Temporal Response of Left Ventricular Performance to Mitral Valve Surgery," vol. 59, No. 6, Jun. 1979, pp. 1218-1231.
- Huikuri, "Effect of Mitral Valve Replacement on Left Ventricular Function in Mitral Regurgitation," *Br. Heart J.*, vol. 49, 1983, pp. 328-333.
- Pitavys II et al., "Long-Term Effects of Excision of the Mitral Apparatus on Global and Regional Ventricular Function in Humans," *JACC*, vol. 15, No. 3, Mar. 1, 1990, pp. 557-563.
- Bolling et al., "Surgery for Acquired Heart Disease/Early Outcome of Mitral Valve Reconstruction in Patients with End-Stage Cardiomyopathy," *The Journal of Thoracic and Cardiovascular Surgery*, vol. 109, No. 4, Apr. 1995, pp. 676-683.
- Masahiro et al., "Surgery for Acquired Heart Disease/Effects of Preserving Mitral Apparatus on Ventricular Systolic Function in Mitral Valve Operations in Dogs," *The Journal of Thoracic and Cardiovascular Surgery*, vol. 106, No. 6, Dec. 1993, pp. 1138-1146.
- Dickstein et al., "Heart Reduction Surgery: An Analysis of the Impact on Cardiac Function," *The Journal of Thoracic and Cardiovascular Surgery*, vol. 113, No. 6, Jun. 1997, 9 pages.
- McCarthy et al., "Early Results with Partial Left Ventriculectomy," From the Departments of Thoracic and Cardiovascular Surgery, Cardiology, and Transplant Center, Cleveland Clinic Foundation, Presented at the 77<sup>th</sup> Annual Meeting of the American Association of Thoracic Surgeons, May 1997, 33 pages.
- Alonso-Lej, M.D., "Adjustable Annuloplasty for Tricuspid Insufficiency," *The Annals of Thoracic Surgery*, vol. 46, No. 3, Sep. 1988, 2 pages.
- Kurlansky et al., "Adjustable Annuloplasty for Tricuspid Insufficiency," *Ann. Thorac. Surg.*, 44:404-406, Oct. 1987.
- Savage, M.D., "Repair of left ventricular aneurysm," *The Journal of Thoracic and Cardiovascular Surgery*, vol. 104, No. 3, Sep., 1992, pp. 752-762.
- Melvin, "Ventricular Radius Reduction Without Resection: A Computational Analysis," *ASAIO Journal*, 45:160-165, 1999.
- Cox, "Left Ventricular Aneurysms: Pathophysiologic Observations and Standard Resection," *Seminars in Thoracic and Cardiovascular Surgery*, vol. 9, No. 2, Apr., 1997, pp. 113-122.
- Boyd et al., "Tricuspid Annuloplasty," *The Journal of Thoracic and Cardiovascular Surgery*, vol. 68, No. 3, Sep. 1974, 8 pages.
- acorn cardiovascular, inc., "Acorn Cardiovascular Sum-

acorn cardiovascular, inc., "Acorn Cardiovascular Company Overview", undated.

Batista, MD et al., "Partial Left Ventriculectomy to Treat End-Stage Heart Disease", *Ann. Thorac. Surg.*, 64:634-8, 1997.

Melvin DB et al., Reduction of Ventricular Wall Tensile Stress by Geometric Remodeling Device, *Poster text, ASAIO* 1999.

McCarthy, Transcription of Mar. 13, 2000 Presentation.

acorn cardiovascular, inc., "Acorn Cardiovascular Abstracts", Nov. 13, 2000.

Nation's First "Heart Jacket" Surgery to Treat Heart Failure Performed at HUP: Novel "Cardiac Support Device" Comes to America After Promising Results in Europe, Jun. 26, 2000.

acorn cardiovascular, inc., Acorn Cardiovascular Company Overview, Jun. 2000.

acorn cardiovascular, inc., Acorn Cardiovascular Business Plan, May 2000.

acorn cardiovascular, inc., "Acorn Cardiovascular Highlights Abstracts", Mar. 10, 1999.

acorn cardiovascular, inc., "Acorn Cardiovascular Highlights Abstracts", Apr. 19, 1999.

acorn cardiovascular, inc., "Acorn Cardiovascular Highlights Abstracts", Oct. 1, 1999.

acorn cardiovascular, inc., "Acorn Cardiovascular Highlights Abstracts", Nov. 9, 1999.

Melvin DB, "Ventricular Radius-Reduction Without Resection A Computational Assessment", undated.

Melvin DB et al., Reduction of Ventricular Wall Tensile Stress by Geometric Remodeling Device, undated.

\* cited by examiner

# Explore Litigation Insights

Docket Alarm provides insights to develop a more informed litigation strategy and the peace of mind of knowing you're on top of things.

## Real-Time Litigation Alerts



Keep your litigation team up-to-date with **real-time alerts** and advanced team management tools built for the enterprise, all while greatly reducing PACER spend.

Our comprehensive service means we can handle Federal, State, and Administrative courts across the country.

## Advanced Docket Research



With over 230 million records, Docket Alarm's cloud-native docket research platform finds what other services can't. Coverage includes Federal, State, plus PTAB, TTAB, ITC and NLRB decisions, all in one place.

Identify arguments that have been successful in the past with full text, pinpoint searching. Link to case law cited within any court document via Fastcase.

## Analytics At Your Fingertips



Learn what happened the last time a particular judge, opposing counsel or company faced cases similar to yours.

Advanced out-of-the-box PTAB and TTAB analytics are always at your fingertips.

## API

Docket Alarm offers a powerful API (application programming interface) to developers that want to integrate case filings into their apps.

## LAW FIRMS

Build custom dashboards for your attorneys and clients with live data direct from the court.

Automate many repetitive legal tasks like conflict checks, document management, and marketing.

## FINANCIAL INSTITUTIONS

Litigation and bankruptcy checks for companies and debtors.

## E-DISCOVERY AND LEGAL VENDORS

Sync your system to PACER to automate legal marketing.