



US005232243A

United States Patent [19]
Blackburn et al.

[11] **Patent Number:** **5,232,243**
[45] **Date of Patent:** **Aug. 3, 1993**

- [54] **OCCUPANT SENSING APPARATUS**
- [75] **Inventors:** **Brian K. Blackburn**, Rochester;
Joseph F. Mazur, Washington; **Scott B. Gentry**, Shelby Township,
Macomb County, all of Mich.
- [73] **Assignee:** **TRW Vehicle Safety Systems Inc.**,
Lyndhurst, Ohio
- [21] **Appl. No.:** **682,908**
- [22] **Filed:** **Apr. 9, 1991**
- [51] **Int. Cl.⁵** **B60R 21/32**
- [52] **U.S. Cl.** **280/732; 280/735;**
180/273
- [58] **Field of Search** 280/728, 730, 731, 732,
280/735; 180/273

FOREIGN PATENT DOCUMENTS

0357225 3/1990 European Pat. Off. .
3839134C1 2/1990 Fed. Rep. of Germany .

OTHER PUBLICATIONS

Interlink Electronics "Force and Position Sensing Resistors: An Emerging Technology".
Tekscan Corporate Capabilities.
Kynar Piezo Film Technical Manual.

Primary Examiner—Richard A. Schacher
Attorney, Agent, or Firm—Tarolli, Sundheim & Covell

[57] **ABSTRACT**

An occupant sensing apparatus for use in an occupant restraint system comprises a film having an electrical characteristic with changeable states and a contact member. When an occupant sits in a vehicle seat, the contact member pushes on the film and changes the state of the electrical characteristic. An electric circuit is connected to the film for providing a first signal when the film indicates an occupant is not present, a second signal when an occupant is present, and a third signal if the film and the circuit become disconnected. The occupant restraint system is enabled when either an occupant is present or an electrical fault condition occurs. In accordance with another embodiment of the invention, an array of sensors located in the seat determines the occupant's position and weight and controls deployment of the occupant restraint system in response to the determined position and weight.

[56] **References Cited**

U.S. PATENT DOCUMENTS

3,172,684	3/1965	Isaac	280/735 X
3,340,523	9/1967	Whitman	
3,672,699	6/1972	DeWindt	
3,746,844	7/1973	Azum et al.	
3,992,028	11/1976	Abe et al.	
4,700,180	10/1987	Vance	
4,796,013	1/1989	Yasuda et al.	
4,804,859	2/1989	Swart	
4,810,005	3/1989	Fohl	
4,833,457	5/1989	Graebe, Jr.	
4,876,419	10/1989	Lodini	
4,876,420	10/1989	Lodini	
5,071,160	12/1991	White	280/735
5,071,160	12/1991	White et al.	
5,074,583	12/1991	Fujita	280/735
5,079,949	1/1992	Tamori	

9 Claims, 14 Drawing Sheets

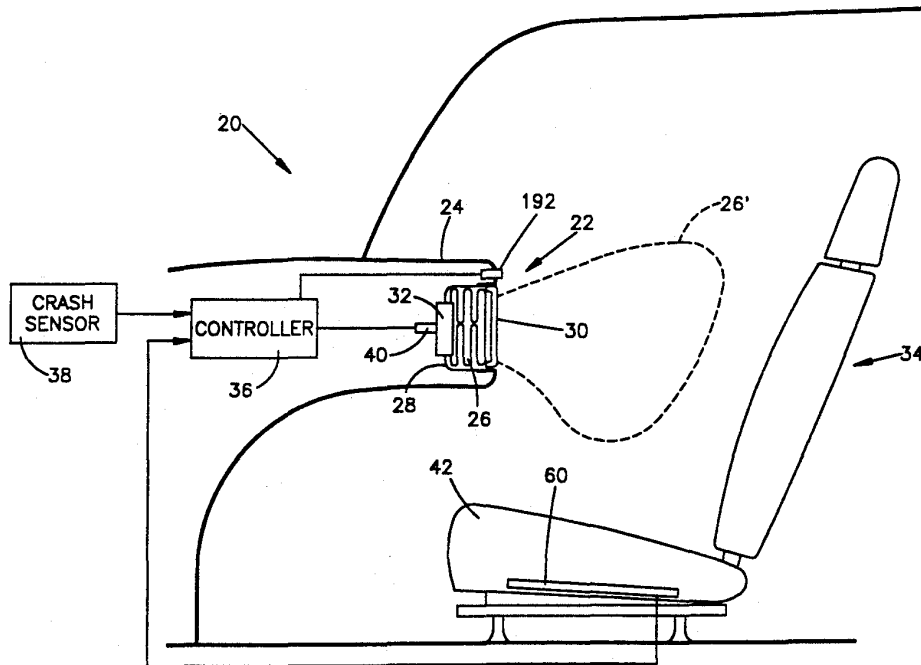

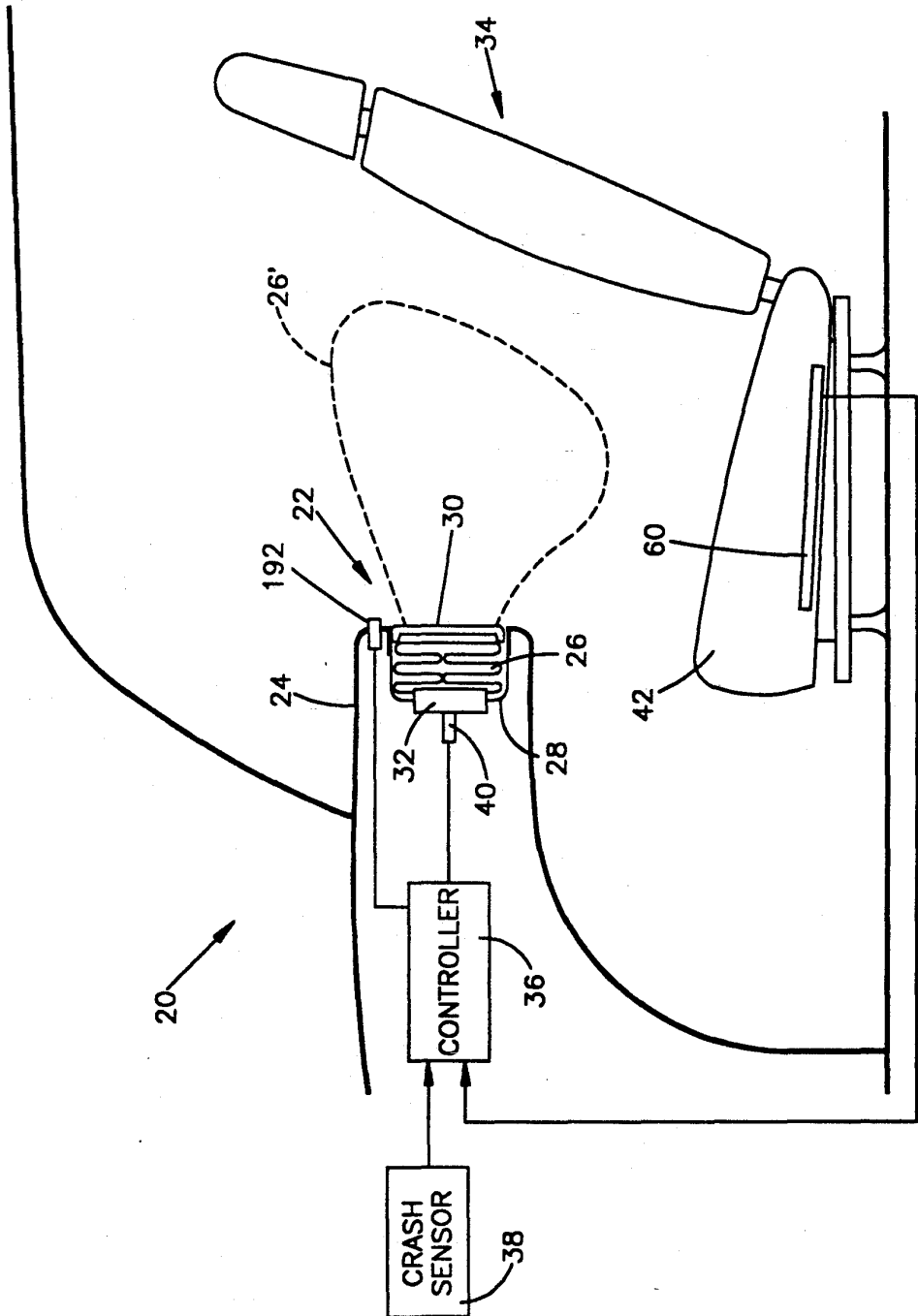
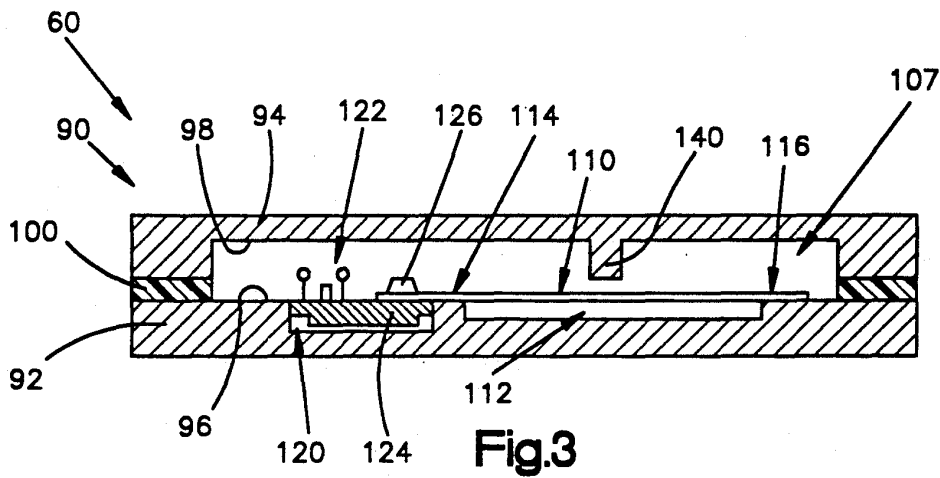
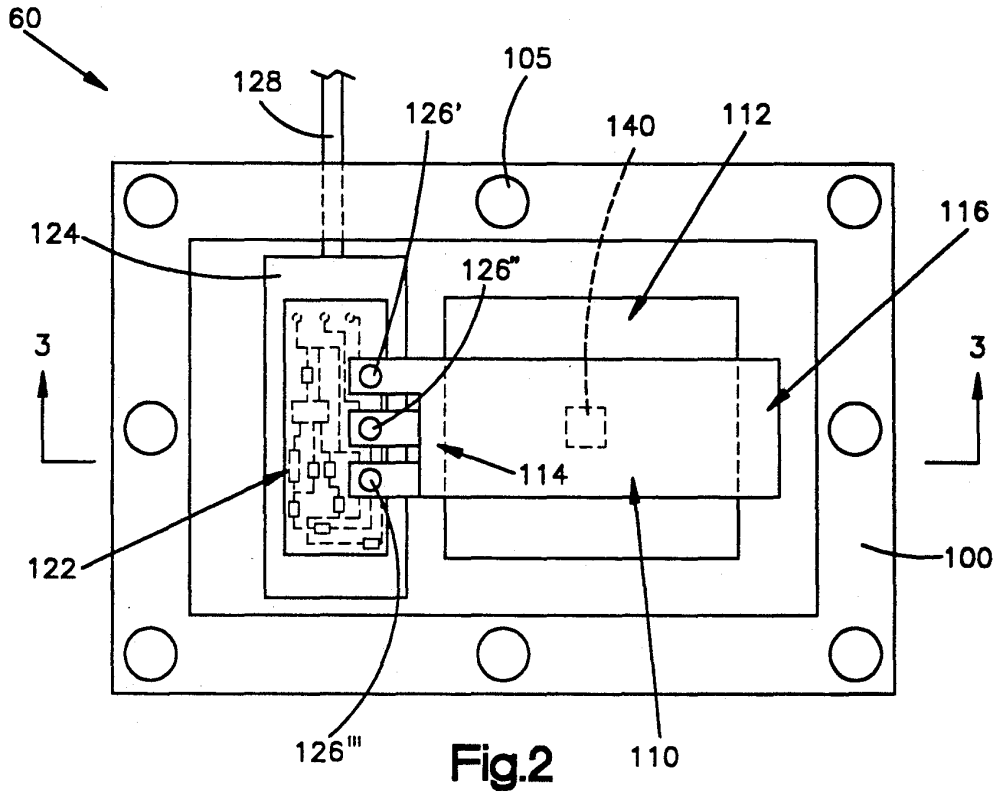

Fig.1



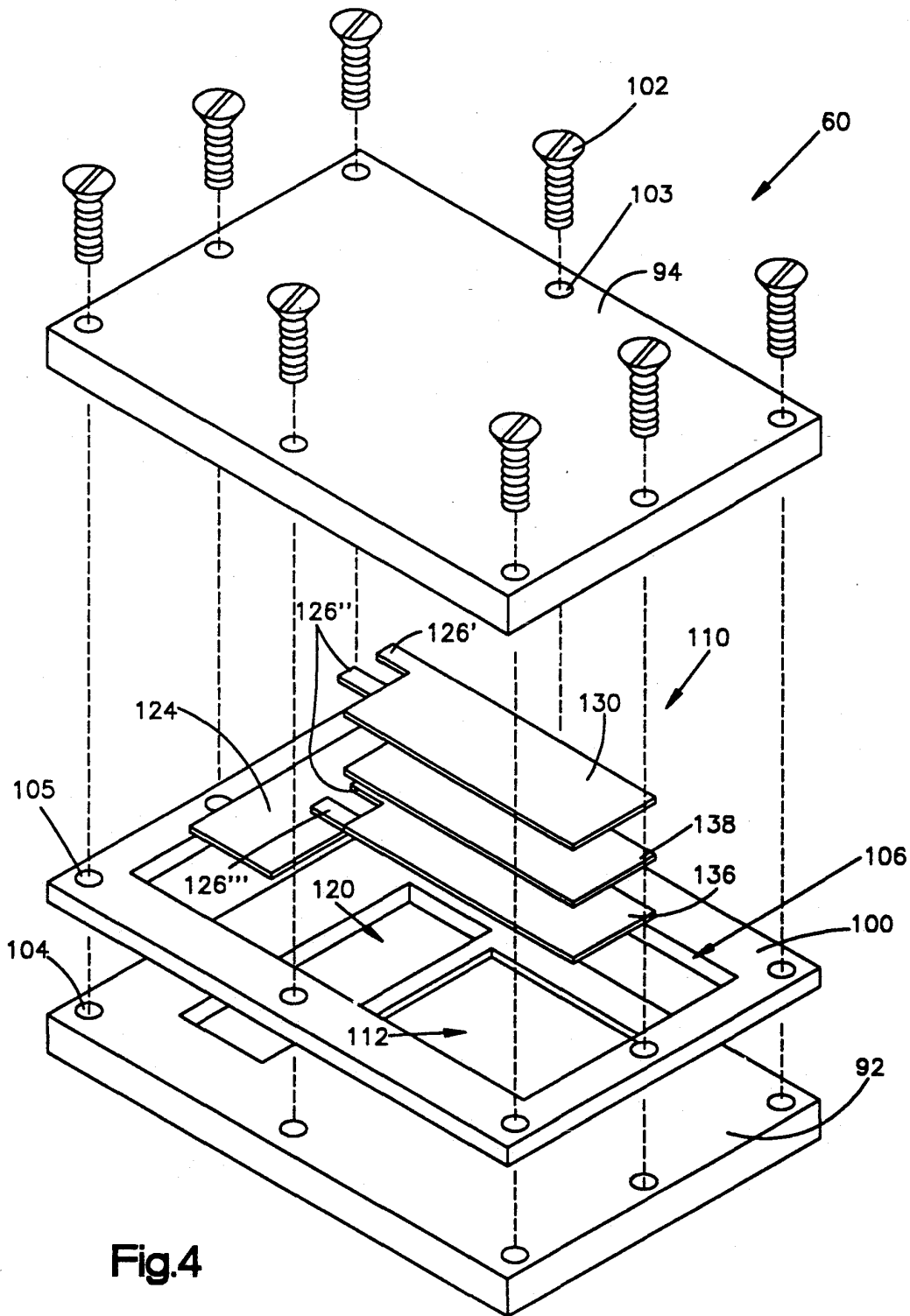

Fig.4

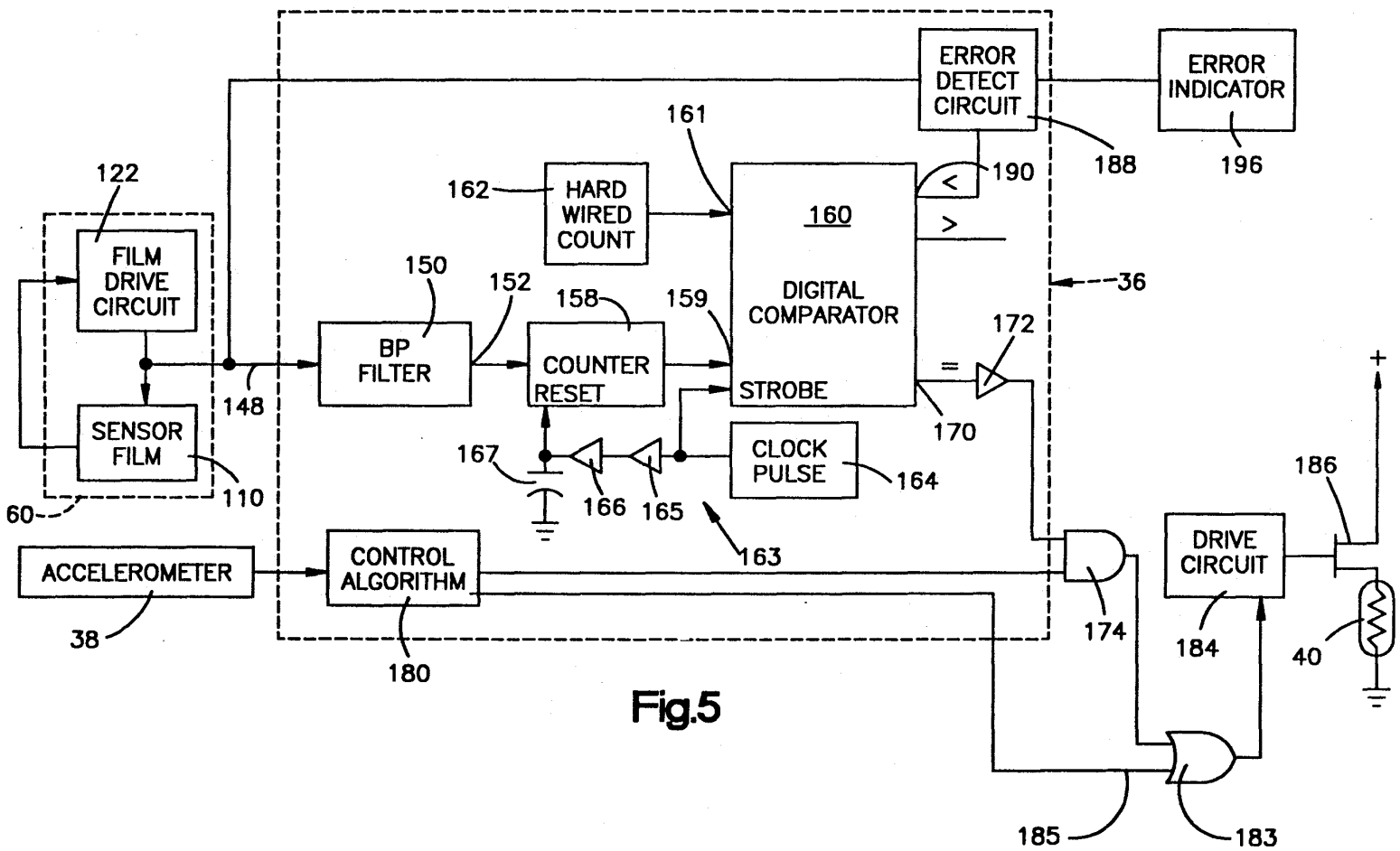

Fig.5

Explore Litigation Insights

Docket Alarm provides insights to develop a more informed litigation strategy and the peace of mind of knowing you're on top of things.

Real-Time Litigation Alerts



Keep your litigation team up-to-date with **real-time alerts** and advanced team management tools built for the enterprise, all while greatly reducing PACER spend.

Our comprehensive service means we can handle Federal, State, and Administrative courts across the country.

Advanced Docket Research



With over 230 million records, Docket Alarm's cloud-native docket research platform finds what other services can't. Coverage includes Federal, State, plus PTAB, TTAB, ITC and NLRB decisions, all in one place.

Identify arguments that have been successful in the past with full text, pinpoint searching. Link to case law cited within any court document via Fastcase.

Analytics At Your Fingertips



Learn what happened the last time a particular judge, opposing counsel or company faced cases similar to yours.

Advanced out-of-the-box PTAB and TTAB analytics are always at your fingertips.

API

Docket Alarm offers a powerful API (application programming interface) to developers that want to integrate case filings into their apps.

LAW FIRMS

Build custom dashboards for your attorneys and clients with live data direct from the court.

Automate many repetitive legal tasks like conflict checks, document management, and marketing.

FINANCIAL INSTITUTIONS

Litigation and bankruptcy checks for companies and debtors.

E-DISCOVERY AND LEGAL VENDORS

Sync your system to PACER to automate legal marketing.