

UNITED STATES PATENT AND TRADEMARK OFFICE

BEFORE THE PATENT TRIAL AND APPEAL BOARD

GEMOLOGICAL INSTITUTE OF AMERICA INC.
Petitioner,

v.

DIAMOND GRADING TECHNOLOGIES LLC
Patent Owner.

Case IPR2016-00456
Patent RE44,963

Before SALLY C. MEDLEY, TRENTON A. WARD, and
WILLIAM M. FINK, *Administrative Patent Judges*.

FINK, *Administrative Patent Judge*.

DECISION
Denying Institution of *Inter Partes* Review
37 C.F.R. § 42.108

I. INTRODUCTION

Gemological Institute of America, Inc. (“Petitioner”) filed a Petition requesting an *inter partes* review of claims 1, 14, 16, 17, 32, 34, 35, 53, 55, 76, 79, 80, 82, 83, 85, 88, 94, 98, 114, and 120 of U.S. Patent No. RE44,963 (Ex. 1001, “the RE’963 patent”). Paper 2 (“Pet.”). Patent Owner, Diamond Grading Technologies, filed a Preliminary Response. Paper 6 (“Prelim. Resp.”). We have jurisdiction under 35 U.S.C. § 314, which provides that an *inter partes* review may not be instituted “unless . . . the information presented in the petition . . . and any response . . . shows that there is a reasonable likelihood that the petitioner would prevail with respect to at least 1 of the claims challenged in the petition.”

For the reasons that follow, we determine that Petitioner has not established a reasonable likelihood of prevailing with respect to at least one of claims 1, 14, 16, 17, 32, 34, 35, 53, 55, 76, 79, 80, 82, 83, 85, 88, 94, 98, 114, and 120 of the RE’963 patent. Accordingly, we deny the Petition and do not institute an *inter partes* review.

A. Related Matters

Petitioner and Patent Owner identify the following pending matters as relating to the RE’963 patent: *Diamond Grading Technologies LLC v. American Gem Society LLC*, No. 2:14-cv-1161 (E.D. Tx.) and *Diamond Grading Technologies LLC v. Gemological Institute of America*, No: 2:14-cv-1162 (E.D. Tx.). Pet. 1; Paper 5, 1–2. The RE’963 patent is also the subject of a concurrently filed Petition in IPR2016-00455. Pet. 2; Paper 5, 2.

B. The RE’963 Patent

The RE’963 patent relates “generally to gemstones, and more particularly to a computer-based system and method for evaluation of a

gemstone by modeling light propagating through the gemstone.” Ex. 1001, 1:14–17. By way of background, the RE’963 patent discusses the 1919 work of Antwerp diamond cutter Marcel Tolkowsky, who established the mathematical basis for an optimal brilliant cut of a diamond in wide use today. *Id.* at 1:20–26. However, according to the RE’963 patent, Tolkowsky’s model is two-dimensional and, therefore, does not account for full three-dimensional reflective and refractive effects, nor does it provide for variations in facet types, sizes, positions, or asymmetries in some cuts. *Id.* at 1:32–37. Moreover, Tolkowsky’s model relies upon a single incident ray of light, which does not account for the normal illumination from a myriad of directions. *Id.* at 1:38–42.

Accordingly, the RE’963 patent describes a computer-based system for evaluating and grading a gemstone cut using a data set that includes the material characteristics of the stone and geometrical cut data for an existing or proposed cut. Ex. 1001, 1:53–65. “According to the invention, an illumination model comprised of one or more light sources is used to ‘illuminate’ the stone. Light beams from the light sources are traced or modeled as they enter the stone, are reflected among the various facets inside the stone, and exit the stone.” *Id.* at 2:1–5. Attributes of light exiting the stone, including intensity, dispersion, scintillation, or others, are measured to evaluate the quality of the cut. *Id.* at 2:5–10.

Figure 1 of the RE’963 patent is reproduced below:

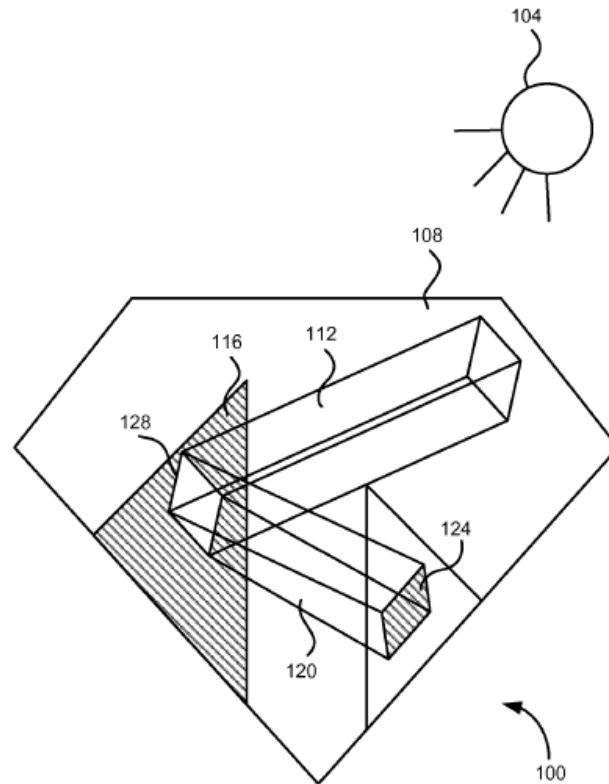

FIG. 1
Amended

Figure 1 is a diagram of light source 104 illuminating gemstone 100. Ex. 1001, 6:25–26. In Figure 1, light beam 112 is refracted into stone 100 by facet 108, and impinges on facet 116. *Id.* at 6:29–30. Depending on its angle of incidence at facet 116, beam 112 creates reflected beam 120 or refracted beam 124. *Id.* at 6:31–32. Although light beam 112 is shown impinging only one facet, in reality it may impinge on multiple facets creating multiple child beams. *Id.* at 6:50–54. The light beam is traced through subsequent reflections and refractions until the light energy is exhausted or sufficiently diminished, and, in a subsequent step, the light refracted out of the stone is evaluated. *Id.* at 7:65–8:8.

C. Illustrative Claim

All challenged claims are independent claims. Claims 1 and 17 are illustrative of the claimed invention and are reproduced below without bracketed text (representing deletions) or italicized text (representing additions):

1. A method for grading the cut of a gemstone, comprising the steps of:

illuminating a computerized gemstone model using a computerized illumination model, wherein said gemstone model is a full three-dimensional (3D) representation of said gemstone that defines the geometry and position of all of the gemstone facets, and wherein said illumination model produces a light beam;

refracting said light beam into said gemstone model through a first facet of said gemstone model to produce a refracted light beam, said refracted light beam via said first facet of said gemstone model is modeled with a three-dimensional shape and the three-dimensional shape of the refracted light beam is defined by an area of said first facet;

reflecting said refracted light beam within said gemstone model from a second facet of said gemstone model to produce a reflected light beam;

refracting said refracted light beam out of said gemstone model through said second facet of said gemstone model;

refracting said reflected light beam out of said gemstone model through a third facet of said gemstone model to produce an exiting light beam; and

measuring said exiting light beam.

17. A method for establishing maximum attribute values for a gemstone cut for use in evaluating gemstones having said gemstone cut comprising the steps of:

Explore Litigation Insights

Docket Alarm provides insights to develop a more informed litigation strategy and the peace of mind of knowing you're on top of things.

Real-Time Litigation Alerts



Keep your litigation team up-to-date with **real-time alerts** and advanced team management tools built for the enterprise, all while greatly reducing PACER spend.

Our comprehensive service means we can handle Federal, State, and Administrative courts across the country.

Advanced Docket Research



With over 230 million records, Docket Alarm's cloud-native docket research platform finds what other services can't. Coverage includes Federal, State, plus PTAB, TTAB, ITC and NLRB decisions, all in one place.

Identify arguments that have been successful in the past with full text, pinpoint searching. Link to case law cited within any court document via Fastcase.

Analytics At Your Fingertips



Learn what happened the last time a particular judge, opposing counsel or company faced cases similar to yours.

Advanced out-of-the-box PTAB and TTAB analytics are always at your fingertips.

API

Docket Alarm offers a powerful API (application programming interface) to developers that want to integrate case filings into their apps.

LAW FIRMS

Build custom dashboards for your attorneys and clients with live data direct from the court.

Automate many repetitive legal tasks like conflict checks, document management, and marketing.

FINANCIAL INSTITUTIONS

Litigation and bankruptcy checks for companies and debtors.

E-DISCOVERY AND LEGAL VENDORS

Sync your system to PACER to automate legal marketing.