

---

# Introduction to Optics and Lasers in Engineering

---

Gabriel Laufer

*University of Virginia*



CAMBRIDGE  
UNIVERSITY PRESS

CAMBRIDGE UNIVERSITY PRESS  
Cambridge, New York, Melbourne, Madrid, Cape Town,  
Singapore, São Paulo, Delhi, Tokyo, Mexico City

Cambridge University Press  
The Edinburgh Building, Cambridge CB2 8RU, UK

Published in the United States of America by Cambridge University Press, New York

www.cambridge.org  
Information on this title: www.cambridge.org/9780521452335

© Cambridge University Press 1996

This publication is in copyright. Subject to statutory exception  
and to the provisions of relevant collective licensing agreements,  
no reproduction of any part may take place without the written  
permission of Cambridge University Press.

First published 1996

*A catalogue record for this publication is available from the British Library*

*Library of Congress Cataloguing in Publication Data*

Laufer, Gabriel

Introduction to optics and lasers in engineering / Gabriel Laufer.

p. cm.

Includes bibliographical references and index.

ISBN 0-521-45233-3 (hc)

1. Lasers in engineering. 2. Optics. I. Title.

TA367.5.L39 1996

621.36'6 - dc20

95-44046  
CIP

ISBN 978-0-521-45233-5 Hardback

ISBN 978-0-521-01762-6 Paperback

Cambridge University Press has no responsibility for the persistence or  
accuracy of URLs for external or third-party internet websites referred to in  
this publication, and does not guarantee that any content on such websites is,  
or will remain, accurate or appropriate. Information regarding prices, travel  
timetables, and other factual information given in this work is correct at  
the time of first printing but Cambridge University Press does not guarantee  
the accuracy of such information thereafter.

the transformation of Gaussian beams by lens. Such equations are expected to describe the size of the waist behind a lens or its location relative to the lens. Similarly, equations that describe the oscillation of Gaussian beams inside laser cavities are needed for cavity design. Although the formation of Gaussian beams in a resonator logically should be considered before examining beam transformation by lenses, the latter information is needed to analyze the cavities and will therefore be presented next.

### 13.3 Transformation of a Gaussian Beam by a Lens

The beam parameter  $q(z)$  (eqn. 13.12) and the phase-shift parameter  $P(z)$  (eqn. 13.15) fully characterize Gaussian laser beams. Therefore, the propagation of a laser beam through optical media, or its transformation by lenses or mirrors, can be generally modeled by evaluating  $q(z)$  and  $P(z)$  at the input and output planes of an optical element. However, in the absence of absorption losses (or gain), the real and imaginary components of the complex beam parameter  $q(z)$  can be used to fully specify  $P(z)$  (see Problem 13.2). Therefore, the propagation through nonlossy media can be described by simply evaluating  $q(z)$  at each point. Similarly, transformation by an optical element, such as a lens, can be described by evaluating  $q_1$  and  $q_2$ , the beam parameters at the input and output planes of that element (Kogelnik 1965a). The relation between  $q_1$  and  $q_2$  for such transformation must then be specific to that element. Beam propagation through a train of optical elements and through the separating media between them can be described by applying consecutively the transformation function of the various elements.

The transformation of radiation by optical elements can also be analyzed by geometrical optics, where the paths of geometrical rays is drawn. Therefore, it can be expected that some of the techniques of geometrical optics will also be applicable to the analysis of propagating laser beams. In particular, the method of ray transfer matrices (Section 2.8) is adopted here to describe the transformation of Gaussian beams by lenses and mirrors. This method is extremely useful for describing the transformation by several consecutive elements or an oscillation between the mirrors of a laser cavity. Similarly to geometrical optics, each element will be described by a  $2 \times 2$  matrix (Figure 13.5). However, unlike geometrical optics, where the matrix is used to compute  $r$  and  $r'$  (eqn. 2.17), here it will be used to calculate the real and imaginary components of  $q_2$  in terms of the two components of  $q_1$ .

To develop the equation for the transformation of a Gaussian beam by a lens, consider first as an analogy the transformation by a lens of a spherical wave with a radius of curvature  $R_1$ . The curvature is defined as positive if it is concave when viewed from the left side of the front. For radiation emitted by an ideal point source, this curvature for propagation to the right is simply the distance to the source  $R_1 = s_1$ . After being focused by a lens of focal length  $f$ , the wave is transformed into a new spherical wave with a curvature  $-R_2$  propagating toward a point at a distance  $s_2 = -R_2$  away. Therefore, by replacing  $s_1$  and

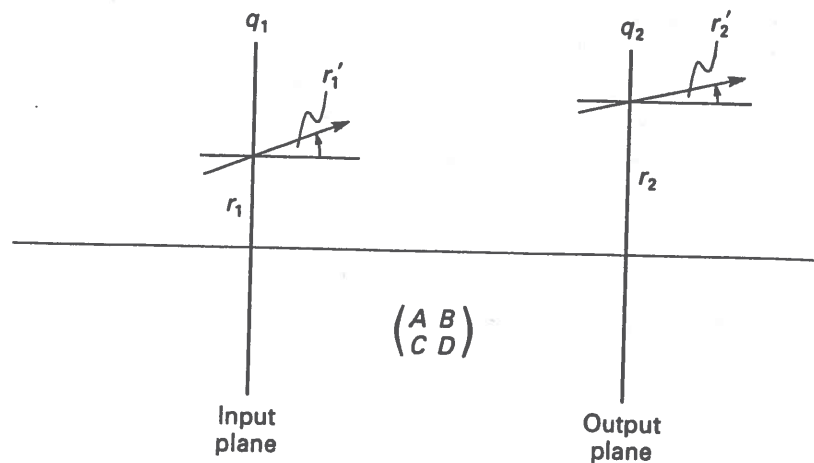

**Figure 13.5** Schematic presentation of a transforming optical element, showing the ray and beam parameters at the input and output planes and the ray transfer matrix of that element.

$s_2$  with  $R_1$  and  $-R_2$ , the lens equation (eqn. 2.10) can also be used to describe the curvatures of the incident and transmitted beams:

$$\frac{1}{R_2} = \frac{1}{R_1} - \frac{1}{f}$$

(see Problem 13.3).

A more general expression that describes the transformation of a spherical wave by any optical element can be obtained by assuming that, for paraxial propagation,  $R \approx r/r'$ . Since  $r_2$  and  $r_2'$  at the output plane of an optical element can be calculated by the ray transfer matrix when  $r_1$  and  $r_1'$  are known, the curvature of the spherical wave at the output plane can also be determined by that matrix from the curvature in the input plane. It can be shown (Problem 13.3) that, for paraxial propagation through an optical component with ray transfer matrix elements  $A$ ,  $B$ ,  $C$ , and  $D$ , the transformation of a spherical wave is

$$R_2 = \frac{AR_1 + B}{CR_1 + D} \quad (13.27)$$

(Kogelnik 1965a).

To extend this result for the analysis of Gaussian laser beams, consider the transmission of a Gaussian beam by a thin, nonabsorbing lens. The beam parameter at the input plane of the lens (eqn. 13.12) is

$$\frac{1}{q_1} = \frac{1}{R_1} + i \frac{\lambda}{\pi w_1^2}$$

For a thin lens, the radius of the beam immediately past the lens is  $w_2 = w_1$ , and the only effect of that lens on the beam is to transform its radius of curvature from  $R_1$  to  $R_2$ :

$$\frac{1}{q_2} - \frac{1}{q_1} = \frac{1}{R_2} - \frac{1}{R_1}.$$

Thus, similarly to the transformation of spherical waves by a lens, the transformation of the beam parameter by a lens is

$$\frac{1}{q_2} = \frac{1}{q_1} - \frac{1}{f}. \quad (13.28)$$

Although the analogy between the beam parameter  $q$  and the radius of curvature of the wavefront  $R$  was shown here only for a transformation by a thin lens, it was generalized (Kogelnik 1965b) to describe transformation by arbitrary elements. For an optical component with ray transfer matrix elements  $A$ ,  $B$ ,  $C$ , and  $D$ , the transformation of the beam parameter similar to (13.27) is:

$$q_2 = \frac{Aq_1 + B}{Cq_1 + D}. \quad (13.29)$$

This is the *ABCD law*. It has been demonstrated to accurately describe paraxial propagation of Gaussian beams through optical elements of interest, including thick lenses, spherical mirrors, and media with varying refraction indices.

To illustrate the utility of the *ABCD law* for deriving the transformation by elements other than a thin lens, consider the propagation through a distance  $z$  in free space. The matrix elements for this propagation are  $A = 1$ ,  $B = z$ ,  $C = 0$ , and  $D = 1$  (Table 2.1). After inserting these elements into (13.29), the following transformation of  $q_1$  is obtained:

$$q_2 = q_1 + z. \quad (13.30)$$

Although this is not a new result (compare it to eqn. 13.6), it demonstrates that the *ABCD law* is not restricted to transformations by thin elements.

The *ABCD law* can also be used to describe the propagation of a Gaussian beam from its waist where its radius is  $w_1$  to a lens located a distance  $d_1$  away, through that lens and then to the new waist a distance  $d_2$  away, where the radius is  $w_2$  (Figure 13.6). When modeled by ray transfer matrices, this transformation

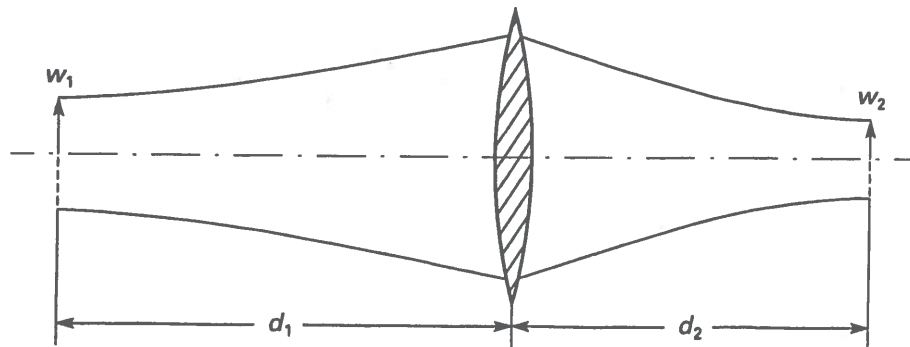

Figure 13.6 Transformation of a Gaussian beam by a lens.

# Explore Litigation Insights

Docket Alarm provides insights to develop a more informed litigation strategy and the peace of mind of knowing you're on top of things.

## Real-Time Litigation Alerts



Keep your litigation team up-to-date with **real-time alerts** and advanced team management tools built for the enterprise, all while greatly reducing PACER spend.

Our comprehensive service means we can handle Federal, State, and Administrative courts across the country.

## Advanced Docket Research



With over 230 million records, Docket Alarm's cloud-native docket research platform finds what other services can't. Coverage includes Federal, State, plus PTAB, TTAB, ITC and NLRB decisions, all in one place.

Identify arguments that have been successful in the past with full text, pinpoint searching. Link to case law cited within any court document via Fastcase.

## Analytics At Your Fingertips



Learn what happened the last time a particular judge, opposing counsel or company faced cases similar to yours.

Advanced out-of-the-box PTAB and TTAB analytics are always at your fingertips.

## API

Docket Alarm offers a powerful API (application programming interface) to developers that want to integrate case filings into their apps.

## LAW FIRMS

Build custom dashboards for your attorneys and clients with live data direct from the court.

Automate many repetitive legal tasks like conflict checks, document management, and marketing.

## FINANCIAL INSTITUTIONS

Litigation and bankruptcy checks for companies and debtors.

## E-DISCOVERY AND LEGAL VENDORS

Sync your system to PACER to automate legal marketing.