

fabric, the resulting bedding retains an exceptionally fine tactile quality critical for providing maximum levels of enhanced comfort.

An alternative to circular knitting is non-circular knitting – for example, warp knitting. This method can achieve widths greater than circular knitting. Industrial warp knit machines, for example, can produce tricote warp knit fabrics up to 130-140 inches in width. Circular knitting, however, is less expensive, as it requires less set-up time. Circular knitting also provides greater multidirectional stretch.

In order to provide a sheet that exceeds the maximum dimensions of fabric that can be produced by available circular knitting machines, flat lock stitching **12** is used to join a plurality of portions resulting in a sheet that is 91 inches wide (as shown). In an exemplary embodiment, piping **11** can be included in close proximity to the stitching. The stitching can be the same color as the fabric of the sheet portions, or different color(s). The piping can be 3/4 inch straight piping without a cord or other filler. In one preferred embodiment, the stitching is 16 stitches per inch. Piping **11** can be included at one end of the sheet and can be the same or a different color as the sheet fabric.

For a fitted sheet, the sheet can include an elastic portion surrounding the edge of the fitted sheet to better keep the fitted sheet in place when placed on a mattress or other sleeping surface. A cord can be sewn into the edge of the fitted sheet and cinched around the mattress or other sleeping surface to better hold the fitted sheet in place.

Referring to **Fig. 2**, a sheet is shown having dimensions of 91 inches wide and 102 inches in length. In this embodiment, stitching **14** is shown 34 inches from an interior edge **18** of a main portion **16** and another stitch **14** at edge **20** of the sewn-on portion. Flat lock stitching can be used for the stitching. Piping can be applied at or in proximity to the stitching.

Referring to **Fig. 3**, a non-rectangular shaped sheet is shown. In this exemplary embodiment, elastic can be included around the edge of the fitted sheet to better maintain the fitted sheet in position when placed on a sleeping surface. In one embodiment, pull ties **24** can be installed at various locations around the edge of the fitted sheet in order to assist in maintaining the fitted sheet secured to the sleeping surface. The pull tie can be cinched to increase tension around the edge of the fitted sheet as shown by **26**.

Stitching used for securing the portions of the sheet together can include that shown as **28a**. In another embodiment, the stitching used for securing the portion of fabric together is shown as **28b**.

Referring to **Fig. 4**, yet another preferred embodiment of the invention is shown. In this embodiment, the sheet can be assembled through stitching of differing fabrics for generating performance zones in the sheet. For example, zone **32** can have higher wicking properties than the other zones since this area is where the majority of the individual body rests. Areas **34a** through **34d** can have higher spandex or other elastic fabric properties so that the fit around a sleeping surface is improved. Area **36** may have thermal properties such as increased cooling since this area is generally where the individual's head lies. In an exemplary embodiment, the pillow covers of pillows used by the individual also have differing properties from the remainder of the sheet, e.g., thermal properties.

The present invention encompasses the construction of bedding materials that have superior performance properties while allowing for manufacture by machinery presently available and in use. More specifically, the invention is related to a new method for fabricating a covering and or sheets in bedding. When using the circular knitting machine, the high gauge performance fabrics can only be made to a maximum size of 72.5 inches without losing the integrity of the spandex in the fabric. Yet, normal sheet panels are 102 x 91 inches. This presents problems when manufacturing sheets from performance fabrics.

Additionally, special stitching techniques must be used given the thread density of the fabric. Using this special stitching, panels are sewn together to produce bedding or a sheet that is the proper size for standard bed sheets. Because discrete portions/panels are used in the manufacture of the present fabrics, panels can be selected that provide different properties for different areas of the bedding (**Fig. 4**). Stitching or seams on the sheet can also allow for the ease of making the bed. Because the bedding is made from performance fabric with spandex, it stretches to permit multiple and custom sizing for applications in cribs, recreational vehicles and boats.

Circular knitting machines used for high gauge performance bedding fabrics are called high-gauge circular knitting machines, because of dense knitting with thin yarn. High gauge generally denotes 17 gauges or more. Seventeen gauges indicate that 17 or more cylinder

needles are contained in one inch. Circular knitting machines of less than 17 gauges are referred to as low-gauge circular knitting machines. The low-gauge circular knitting machines are often used to knit outerwear.

“Yarn count” indicates the linear density (yarn diameter or fineness) to which that particular yarn has been spun. The choice of yarn count is restricted by the type of knitting machine employed and the knitting construction. The yarn count, in turn, influences the cost, weight, opacity, hand and drape of the resulting knitted structure. In general, staple spun yarns tend to be comparatively more expensive the finer their count, because finer fibers and a more exacting spinning process are necessary in order to prevent the yarn from showing an irregular appearance.

A top width in the 90-inch range is currently possible using a circular knit fabric formed on a 36-38-inch diameter machine, although higher levels of spandex in the performance fabric tend to pull the width in. In just one example, on a 30-inch diameter machine, the spandex can reduce an otherwise 94-inch circumference fabric tube to one with a 60-65 inch finished width.

A major limitation in finished width is not strictly a knitting concern but also concerns finishing. With performance fabric, it tends to sag in the middle – increasingly so with greater widths – making finishing difficult to impossible above a certain threshold. A possible 90-inch finished width is contingent upon having a good finishing set-up capable of handling the present performance fabric. This potential for difficulties would only become compounded at the larger widths required for bed sheets.

In a preferred process, the present fabric undergoes a heat setting finishing process. Applying a moisture-wicking finish to another fabric – like cotton – that can be produced at larger widths appears unlikely to match the moisture-control properties of the present fabric, as polyester itself is naturally moisture-resistant and there are physical actions (e.g. capillary action) at play. Further, the use of cotton comes at the expense of breathability and heat-transfer capabilities (as confirmed by laboratory testing) and stretchability.

Numerous characteristics and advantages have been set forth in the foregoing description, together with details of structure and function. While the invention has been disclosed in several forms, it will be apparent to those skilled in the art that many modifications, additions, and deletions, especially in matters of shape, size, and arrangement of parts, can be made therein

without departing from the spirit and scope of the invention and its equivalents as set forth in the following claims. Therefore, other modifications or embodiments as may be suggested by the teachings herein are particularly reserved as they fall within the breadth and scope of the claims here appended.

CLAIMS

What is claimed is:

1. A method of making a finished fabric at least 90 inches wide comprising:
forming at least two discrete performance fabric portions; and
joining at least two discrete performance fabric portions to form the finished fabric.
2. The method according to Claim 1, wherein forming at least two discrete performance fabric portions comprises knitting at least two discrete performance fabric portions.
3. The method according to Claim 1, wherein forming at least two discrete performance fabric portions comprises circular knitting at least two discrete performance fabric portions.
4. The method according to Claim 1, wherein joining at least two discrete performance fabric portions to form the finished fabric comprises stitching at least two discrete performance fabric portions together to form the finished fabric.
5. A method of making a finished fabric at least 90 inches wide comprising:
circular knitting at least two discrete performance fabric portions; and
stitching at least two discrete performance fabric portions together to form the finished fabric.
6. The method according to Claim 5, wherein the finished fabric comprises a bed sheet.
7. The method according to Claim 5, further comprising heat setting finishing the finished fabric.
8. The method according to Claim 5, further comprising providing piping to the finished fabric.
9. A method of making a bed sheet at least 90 inches wide from performance fabric comprising:
circular knitting at least two discrete performance fabric portions;
stitching at least two discrete performance fabric portions together; and

heat setting finishing the stitched at least two discrete performance fabric portions to form the finished bed sheet.

10. The method according to Claim 9, further comprising providing piping to the finished bed sheet.

11. The method according to Claim 9, wherein the at least two discrete performance fabric portions have different fabric characteristics.

12. The method according to Claim 11, wherein fabric characteristics are selected from the group consisting of moisture management, UV protection, anti-microbial, thermo-regulation, wind resistance and water resistance.

13. A finished fabric at least 90 inches wide comprising:

a first circular knitted performance fabric; and

a second circular knitted performance fabric;

wherein the first and second performance fabrics are discrete; and

wherein the first and second performance fabrics are joined to form the finished fabric.

14. The finished fabric of Claim 13, wherein the finished fabric comprises a bed sheet.

15. The finished fabric of Claim 13, further comprising piping.

16. The finished fabric of Claim 13, wherein the first and second performance fabrics have different fabric characteristics.

17. The finished fabric of Claim 16, wherein fabric characteristics are selected from the group consisting of moisture management, UV protection, anti-microbial, thermo-regulation, wind resistance and water resistance.

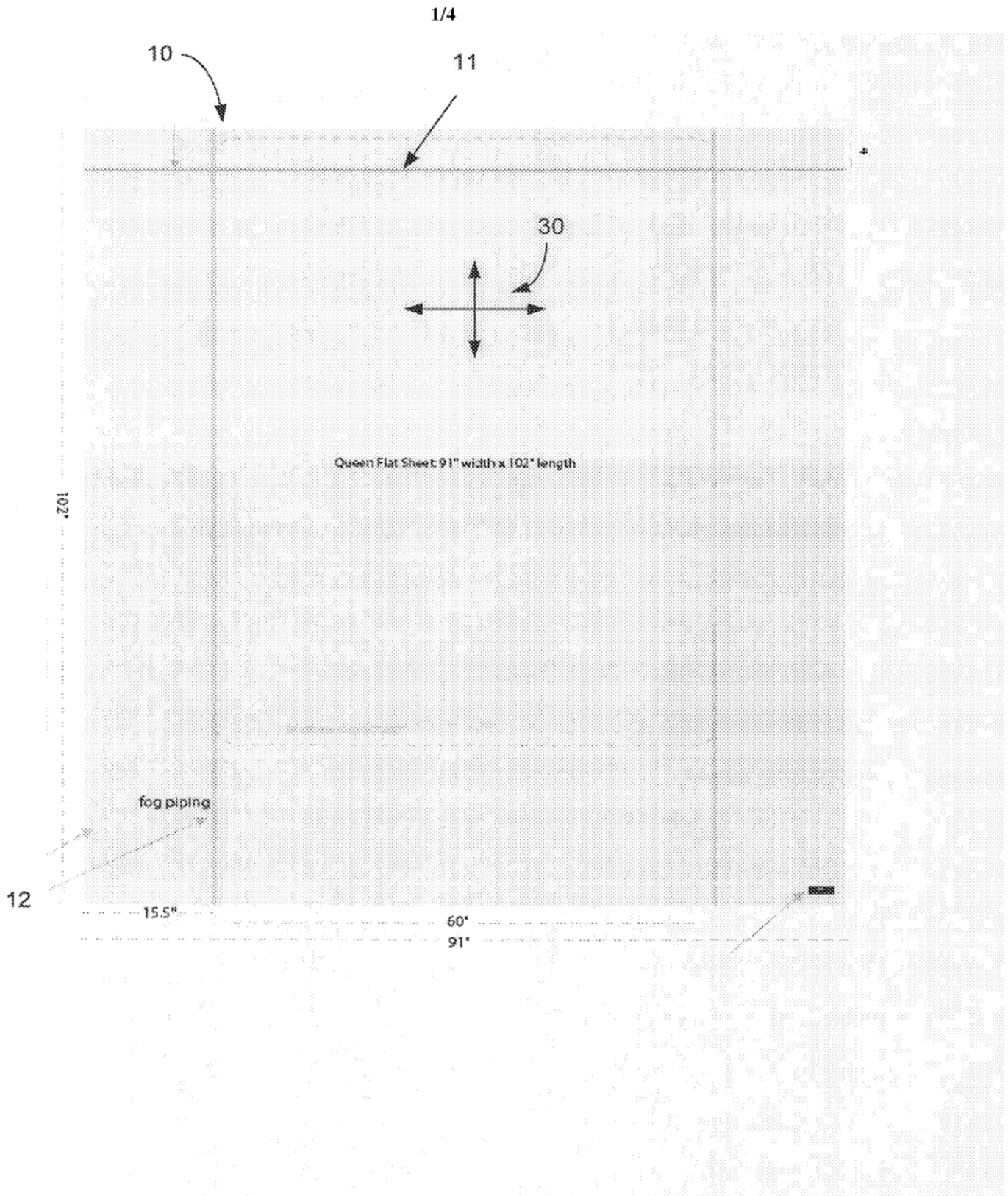

Fig. 1

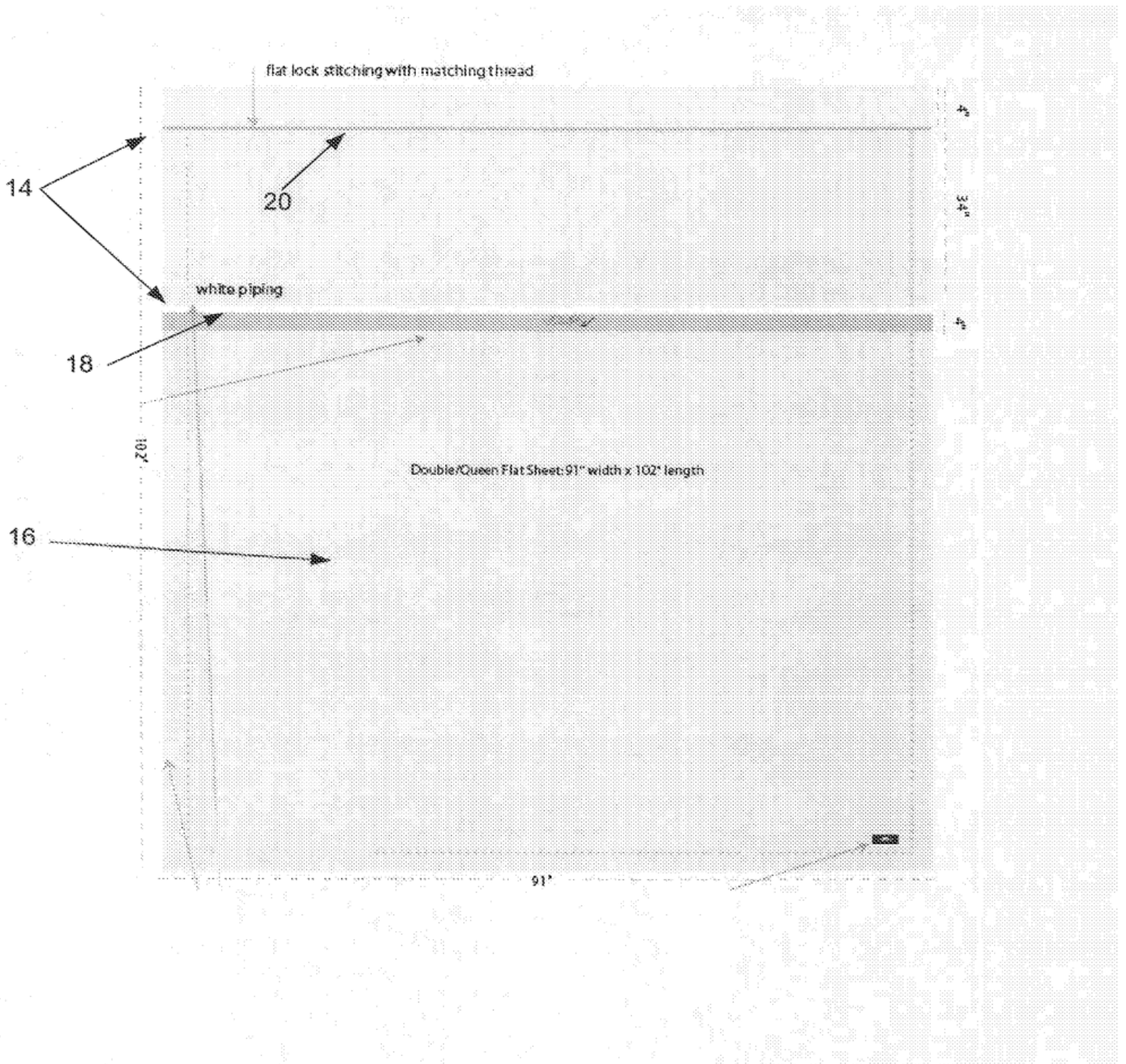

Fig. 2

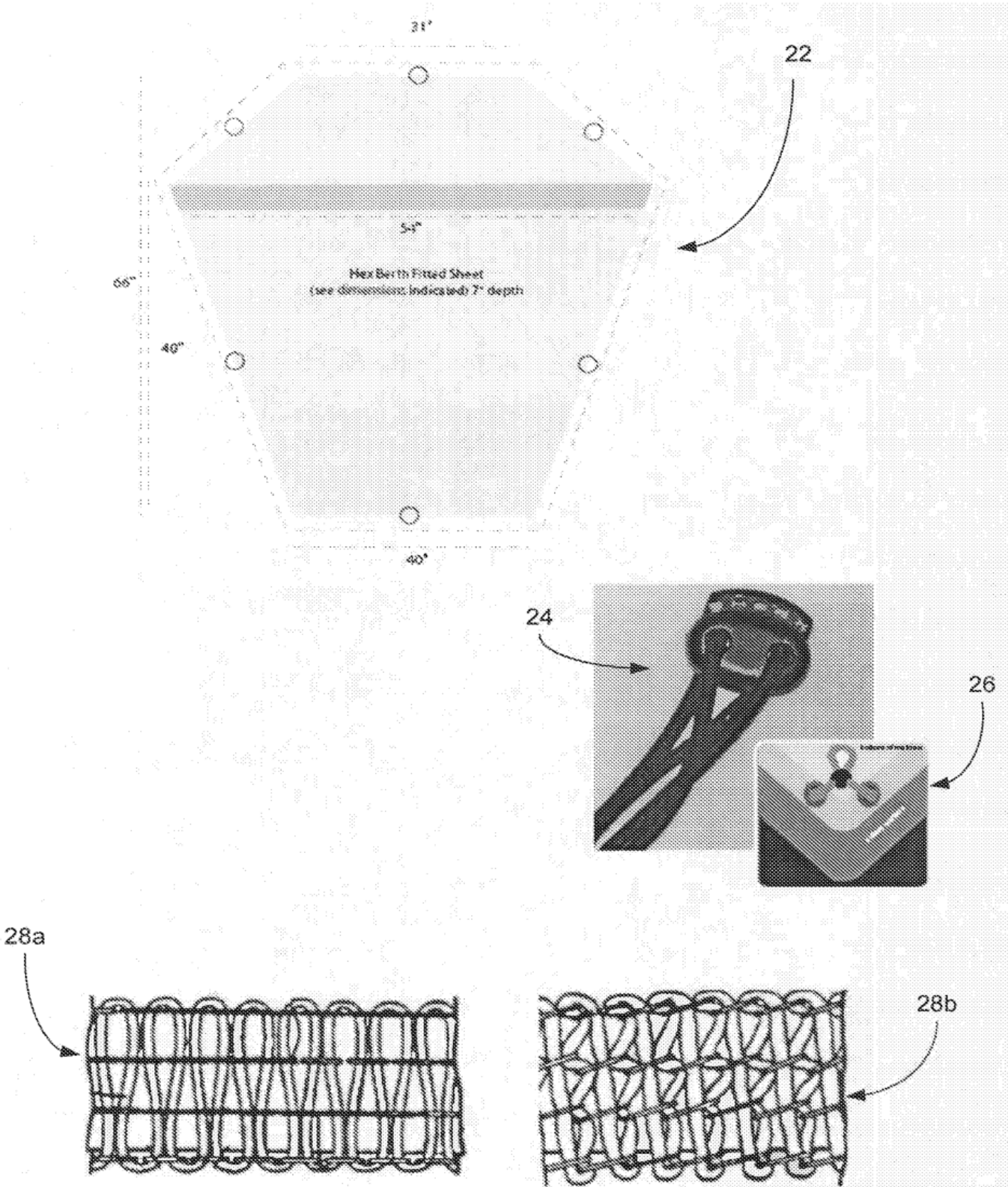

Fig. 3

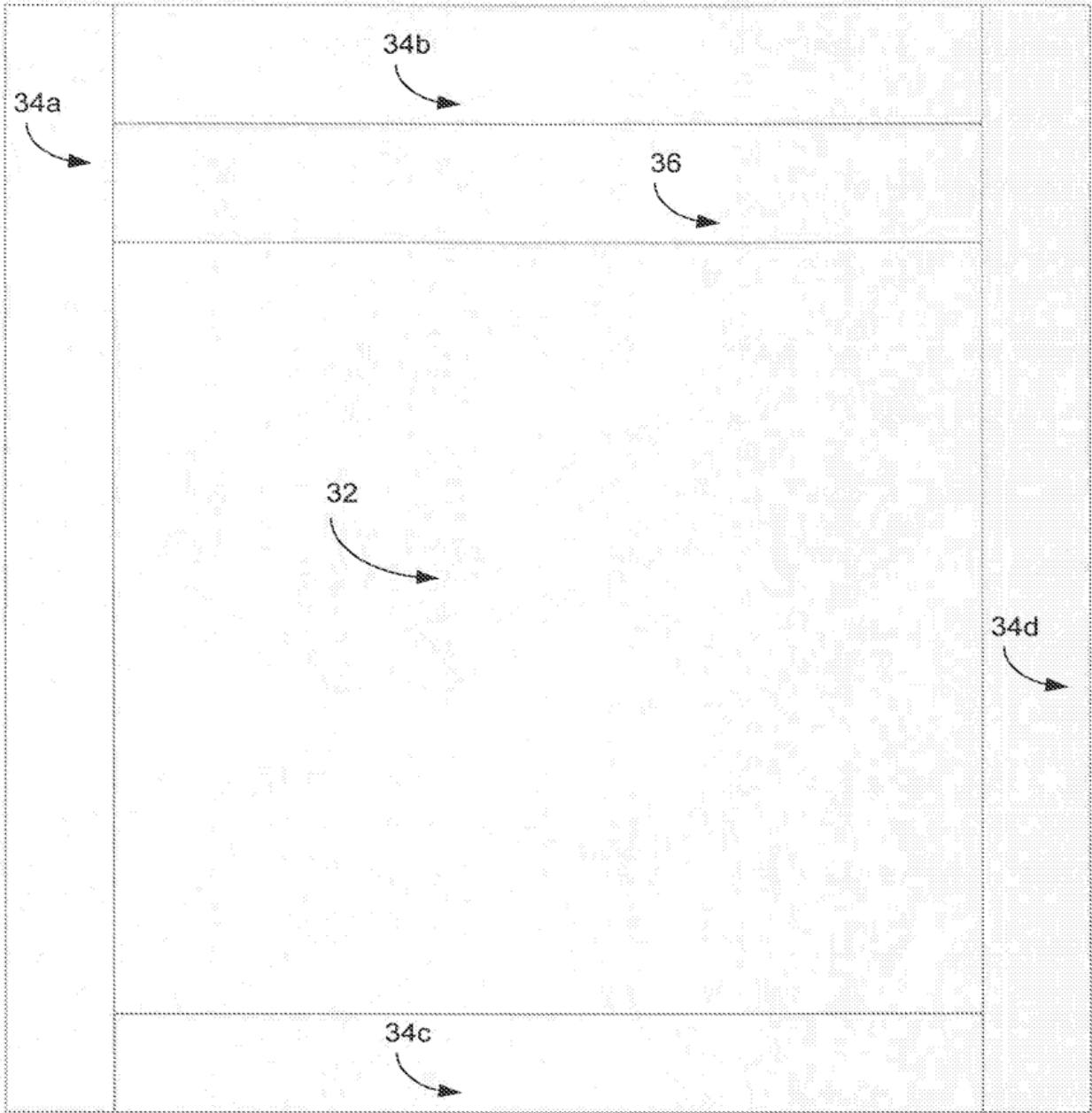

Fig. 4

(19) World Intellectual Property Organization
International Bureau



(43) International Publication Date
1 April 2010 (01.04.2010)

(10) International Publication Number
WO 2010/037082 A3

- (51) International Patent Classification:
D04B 21/14 (2006.01) *D03D 11/00* (2006.01)
- (21) International Application Number:
PCT/US2009/058716
- (22) International Filing Date:
29 September 2009 (29.09.2009)
- (25) Filing Language: English
- (26) Publication Language: English
- (30) Priority Data:
61/101,049 29 September 2008 (29.09.2008) US
- (71) Applicant (for all designated States except US): **SHEEX LLC** [US/US]; 169 Captain Lowman Road, Chapin, SC 29036 (US).
- (72) Inventors; and
- (75) Inventors/Applicants (for US only): **WALVIUS, Susan, Katherine** [US/US]; 169 Captain Lowman Road, Chapin, SC 29036 (US). **MARCINIAK, Michelle, Marie** [US/US]; 169 Captain Lowman Road, Chapin, SC 29036 (US).
- (74) Agent: **SCHNEIDER, Ryan, A.**; Troutman Sanders LLP, Bank of America Plaza, 600 Peachtree Street, N.E., Suite 5200, Atlanta, GA 30308-2216 (US).

(81) Designated States (unless otherwise indicated, for every kind of national protection available): AE, AG, AL, AM, AO, AT, AU, AZ, BA, BB, BG, BH, BR, BW, BY, BZ, CA, CH, CL, CN, CO, CR, CU, CZ, DE, DK, DM, DO, DZ, EC, EE, EG, ES, FI, GB, GD, GE, GH, GM, GT, HN, HR, HU, ID, IL, IN, IS, JP, KE, KG, KM, KN, KP, KR, KZ, LA, LC, LK, LR, LS, LT, LU, LY, MA, MD, ME, MG, MK, MN, MW, MX, MY, MZ, NA, NG, NI, NO, NZ, OM, PE, PG, PH, PL, PT, RO, RS, RU, SC, SD, SE, SG, SK, SL, SM, ST, SV, SY, TJ, TM, TN, TR, TT, TZ, UA, UG, US, UZ, VC, VN, ZA, ZM, ZW.

(84) Designated States (unless otherwise indicated, for every kind of regional protection available): ARIPO (BW, GH, GM, KE, LS, MW, MZ, NA, SD, SL, SZ, TZ, UG, ZM, ZW), Eurasian (AM, AZ, BY, KG, KZ, MD, RU, TJ, TM), European (AT, BE, BG, CH, CY, CZ, DE, DK, EE, ES, FI, FR, GB, GR, HR, HU, IE, IS, IT, LT, LU, LV, MC, MK, MT, NL, NO, PL, PT, RO, SE, SI, SK, SM, TR), OAPI (BF, BJ, CF, CG, CI, CM, GA, GN, GQ, GW, ML, MR, NE, SN, TD, TG).

- Published:**
- with international search report (Art. 21(3))
 - before the expiration of the time limit for amending the claims and to be republished in the event of receipt of amendments (Rule 48.2(h))

[Continued on next page]

(54) Title: FABRIC SYSTEM

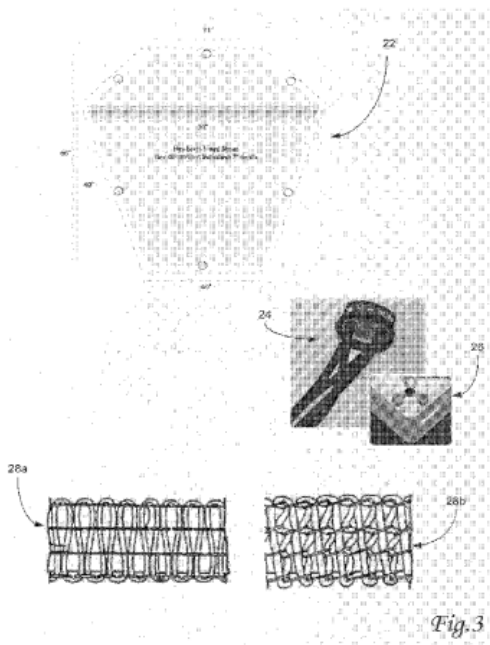

(57) Abstract: Bedding material including a first fabric section manufactured from performance fabric and having a first and second side; and, a second fabric section attached to the first side of the first fabric section. Additionally, a third fabric section can be attached to the second side of the first fabric section. The first fabric section can be attached to the second fabric section through a flatlock stitch. The first fabric section can include a first zone and a second zone wherein the first zone contains different performance properties from the second zone and the first zone can have thermal or moisture wicking properties.



WO 2010/037082 A3

(88) Date of publication of the international search report:
8 July 2010

A. CLASSIFICATION OF SUBJECT MATTER**D04B 21/14(2006.01)i, D03D 11/00(2006.01)i**

According to International Patent Classification (IPC) or to both national classification and IPC

B. FIELDS SEARCHED

Minimum documentation searched (classification system followed by classification symbols)

D04B 21/14; A47G 9/00; A47G 9/02; A61G 7/05; B32B 5/26

Documentation searched other than minimum documentation to the extent that such documents are included in the fields searched

Korean utility models and applications for utility models
Japanese utility models and applications for utility models
(Chinese Patents and application for patent)Electronic data base consulted during the international search (name of data base and, where practicable, search terms used)
eKOMPASS(KIPO internal)**C. DOCUMENTS CONSIDERED TO BE RELEVANT**

Category*	Citation of document, with indication, where appropriate, of the relevant passages	Relevant to claim No.
X	JP 11-309183 A (MORIUCHI KYU KK) 09 November 1999 See paragraphs [0001] and [0010]-[0013]	1-17
X	US 6381779 B1 (THOMPSON; THOMAS L.) 07 May 2002 See claim 1 and figures 4-6	1
A	US 5817391 A1 (ROCK; MOSHE et al.) 06 October 1998 See column 1, line 66 - column 3, line 19	1-17
A	US 5765241 A1 (MACDONALD; ROBERT) 16 June 1998 See the whole document	1-17

 Further documents are listed in the continuation of Box C. See patent family annex.

* Special categories of cited documents:

"A" document defining the general state of the art which is not considered to be of particular relevance

"E" earlier application or patent but published on or after the international filing date

"L" document which may throw doubts on priority claim(s) or which is cited to establish the publication date of citation or other special reason (as specified)

"O" document referring to an oral disclosure, use, exhibition or other means

"P" document published prior to the international filing date but later than the priority date claimed

"T" later document published after the international filing date or priority date and not in conflict with the application but cited to understand the principle or theory underlying the invention

"X" document of particular relevance; the claimed invention cannot be considered novel or cannot be considered to involve an inventive step when the document is taken alone

"Y" document of particular relevance; the claimed invention cannot be considered to involve an inventive step when the document is combined with one or more other such documents, such combination being obvious to a person skilled in the art

"&" document member of the same patent family

Date of the actual completion of the international search

28 APRIL 2010 (28.04.2010)

Date of mailing of the international search report

29 APRIL 2010 (29.04.2010)

Name and mailing address of the ISA/KR

Korean Intellectual Property Office
Government Complex-Daejeon, 139 Seonsa-ro, Seo-
gu, Daejeon 302-701, Republic of Korea

Facsimile No. 82-42-472-7140

Authorized officer

KIM, Jong Kyoo

Telephone No. 82-42-481-5593



INTERNATIONAL SEARCH REPORT

Information on patent family members

International application No.

PCT/US2009/058716

Patent document cited in search report	Publication date	Patent family member(s)	Publication date
JP 11-309183 A	09.11.1999	None	
US 6381779 B1	07.05.2002	US 6678906 B1 WO 0309-2452A1	20.01.2004 13.11.2003
US 5817391 A1	06.10.1998	None	
US 5765241 A1	16.06.1998	AU 1997-12445 B2 EP 0787451 A2 EP 0787451 A3 EP 0787451 B1 GB 2309638 A	27.05.1999 06.08.1997 13.10.1999 04.06.2003 06.08.1997



PATENT ABSTRACTS OF JAPAN

(11) Publication number: **11309183 A**(43) Date of publication of application: **09.11.99**

(51) Int. Cl.
A61G 7/05
A47G 9/02
B32B 5/26
D06M 17/00

(21) Application number: **10132738**(71) Applicant: **MORIUCHI KYU KK**(22) Date of filing: **27.04.98**(72) Inventor: **MATSUMOTO TAKESHI**(54) **WATERPROOF SHEET**

of synthetic fibers such as polyester and a warp-knit fabric such as raschel or tricot are used singularly or in lamination.

(57) Abstract:

PROBLEM TO BE SOLVED: To make urine and sweat absorbed and to prevent bedding, clothes and surrounding from being stained by using a water-permeable and water-diffusive texture for a surface fabric, using a water-impermeable and air-permeable texture by water-repellent finishing for a back fabric, and arranging an intermediate fabric having a water absorbing property and preventing the backflow of moisture between both fabrics.

COPYRIGHT: (C)1999,JPO

SOLUTION: A knit fabric or a woven fabric made of a water-permeable and water-diffusive texture, preferably polyester or other synthetic fibers, and having a proper expansion/shrinkage property is used for a surface fabric 1 to be kept in direct contact with the skin. A knit fabric or a woven fabric made of a water-impermeable and air-permeable texture by water-repellent finishing, preferably polyester or other synthetic fibers, is used for a back fabric 2 to be kept in contact with the mattress of bedding. A nonwoven fabric or a knit fabric having a water absorbing property and having the required thickness to prevent the backflow of absorbed moisture is used for an intermediate fabric 3, and preferably a nonwoven fabric

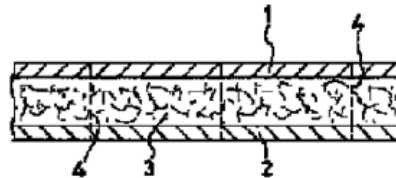

(19) World Intellectual Property Organization
International Bureau



(43) International Publication Date
1 April 2010 (01.04.2010)

(10) International Publication Number
WO 2010/037082 A2

- (51) International Patent Classification:
D04B 21/14 (2006.01) *D03D 11/00* (2006.01)
- (21) International Application Number:
PCT/US2009/058716
- (22) International Filing Date:
29 September 2009 (29.09.2009)
- (25) Filing Language: English
- (26) Publication Language: English
- (30) Priority Data:
61/101,049 29 September 2008 (29.09.2008) US
- (71) Applicant (for all designated States except US): **SHEEX LLC** [US/US]; 169 Captain Lowman Road, Chapin, SC 29036 (US).
- (72) Inventors; and
- (75) Inventors/Applicants (for US only): **WALVIUS, Susan, Katherine** [US/US]; 169 Captain Lowman Road, Chapin, SC 29036 (US). **MARCINIAK, Michelle, Marie** [US/US]; 169 Captain Lowman Road, Chapin, SC 29036 (US).
- (74) Agent: **SCHNEIDER, Ryan, A.**; Troutman Sanders LLP, Bank of America Plaza, 600 Peachtree Street, N.E., Suite 5200, Atlanta, GA 30308-2216 (US).

- (81) Designated States (unless otherwise indicated, for every kind of national protection available): AE, AG, AL, AM, AO, AT, AU, AZ, BA, BB, BG, BH, BR, BW, BY, BZ, CA, CH, CL, CN, CO, CR, CU, CZ, DE, DK, DM, DO, DZ, EC, EE, EG, ES, FI, GB, GD, GE, GH, GM, GT, HN, HR, HU, ID, IL, IN, IS, JP, KE, KG, KM, KN, KP, KR, KZ, LA, LC, LK, LR, LS, LT, LU, LY, MA, MD, ME, MG, MK, MN, MW, MX, MY, MZ, NA, NG, NI, NO, NZ, OM, PE, PG, PH, PL, PT, RO, RS, RU, SC, SD, SE, SG, SK, SL, SM, ST, SV, SY, TJ, TM, TN, TR, TT, TZ, UA, UG, US, UZ, VC, VN, ZA, ZM, ZW.
- (84) Designated States (unless otherwise indicated, for every kind of regional protection available): ARIPO (BW, GH, GM, KE, LS, MW, MZ, NA, SD, SL, SZ, TZ, UG, ZM, ZW), Eurasian (AM, AZ, BY, KG, KZ, MD, RU, TJ, TM), European (AT, BE, BG, CH, CY, CZ, DE, DK, EE, ES, FI, FR, GB, GR, HR, HU, IE, IS, IT, LT, LU, LV, MC, MK, MT, NL, NO, PL, PT, RO, SE, SI, SK, SM, TR), OAPI (BF, BJ, CF, CG, CI, CM, GA, GN, GQ, GW, ML, MR, NE, SN, TD, TG).

Published:
— without international search report and to be republished upon receipt of that report (Rule 48.2(g))

(54) Title: FABRIC SYSTEM

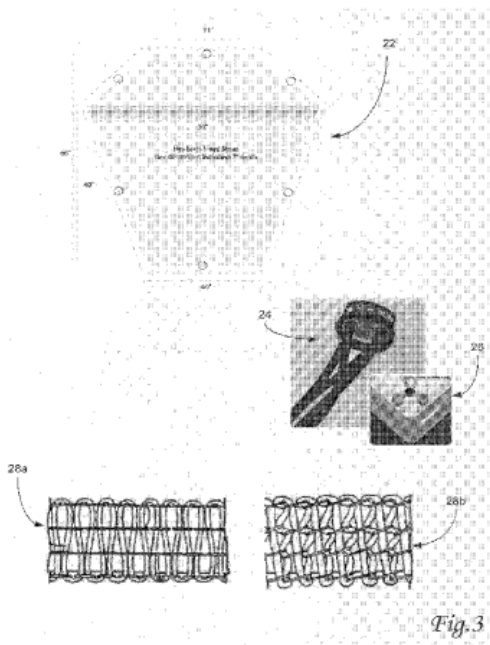

(57) Abstract: Bedding material including a first fabric section manufactured from performance fabric and having a first and second side; and, a second fabric section attached to the first side of the first fabric section. Additionally, a third fabric section can be attached to the second side of the first fabric section. The first fabric section can be attached to the second fabric section through a flatlock stitch. The first fabric section can include a first zone and a second zone wherein the first zone contains different performance properties from the second zone and the first zone can have thermal or moisture wicking properties.

WO 2010/037082 A2

FABRIC SYSTEM

BACKGROUND OF THE INVENTION

1. Field of the Invention

The present invention relates generally to fabric systems, and more specifically to bed coverings constructed of high gauge circular knitted fabrics that accommodate and maintain optimum thermal conditions for sleep, which in turn can lead to faster sleep initiation and deeper, more restorative sleep.

2. Description of Related Art

Sleep problems in the United States are remarkably widespread, affecting roughly three out of four American adults, according to research by the National Sleep Foundation (NSF). Consequently, a great deal of attention has been paid to the circumstances surrounding poor sleep, along with strategies for how to improve it.

The implications are not merely academic. Sleep – not only the right amount of it but also the right quality – impacts not just day-to-day performance, but also “the overall quality of our lives,” according to the NSF. Addressing the causes of poor quality sleep, therefore, has ramifications for millions.

Though many factors contribute to sleep quality, the sleep environment itself plays a critical role, and sleep researchers routinely highlight temperature as one of the most important components in creating an environment for optimal sleep. As advised by the University of Maryland Medical Center, “a cool (not cold) bedroom is often the most conducive to sleep.” The National Sleep Foundation further notes that “temperatures above 75 degrees Fahrenheit and below 54 degrees will disrupt sleep,” with 65 degrees being the ideal sleep temperature for most individuals, according to the NSF.

A lower environmental temperature is not the only thermal factor associated with improved sleep. Researchers have noted a nightly drop in body temperature among healthy, normal adults during sleep. This natural cycle, when inhibited or not functioning properly, can disrupt sleep and delay sleep onset, according to medical researchers at Cornell University. Conversely, the researchers noted, a rapid decline in body temperature not only accelerates sleep onset but also “may facilitate an entry into the deeper stages of sleep.”

Therefore, maintaining an appropriately cool sleep environment and accommodating the body's natural tendency to cool itself at night should be a top priority for individuals interested in optimizing their sleep quality. Performance fabrics crafted into bedding applications would be uniquely capable of promoting cool, comfortable – and therefore better – sleep, as these advanced fabrics maximize breathability and heat transfer. Performance fabrics are made for a variety of end-use applications, and can provide multiple functional qualities, such as moisture management, UV protection, anti-microbial, thermo-regulation, and wind/water resistance.

There has been a long felt need in several industries to provide improved bedding to help individuals get better sleep. Such improved bedding would include beneficial wicking among other properties. For example, in marine, boating and recreational vehicle applications, bedding should resist moisture, fit odd-shaped mattresses and beds, and reduce mildew. Particularly with watercraft, there is a need to protect bedding, and specifically sheets, from moisture and mildew accumulation.

An additional problem with bedding, not just with marine and recreational vehicles, is the sticky, wet feeling that can occur when the bedding sheets are wet due to body sweat, environmental moisture, or other bodily fluids. In particular, when bedding is used during hot weather, or is continuously used for a long time by a person suffering from an illness, problems can arise in that the conventional bed sheet of cotton fiber or the like cannot sufficiently absorb the moisture. All of these issues lead to poor sleep.

To date, performance fabric bedding products are not known. There are width limitations in the manufacturing of high gauge circular knit fabrics, because the finished width of bedding fabrics are dictated by the machine used in its construction. At present, performance fabrics are manufactured with a maximum width of under 90 inches wide, given present manufacturing and technical limitations, along with the inability of alternate manufacturing processes to produce a fabric with identical performance attributes. Yet, normal bed sheet panels can be 102 by 91 inches or larger. Thus, performance fabrics cannot yet be used for bed sheets.

Some conventional solutions for the above issues that hinder a good night's sleep include United States Patent 4,648,186, which discloses an absorbent wood pulp cellulose fiber that is provided in a variety of sizes and is placed under a mattress. The wood pulp is water absorbent and acts to capture moisture to prevent such moisture from being retained by the bedding or the

bedding sheets. However, this proposed solution does not interact with the bedding or the bedding sheets, but merely acts as a sponge for moisture that is in proximity to the target bedding.

United States Patent 5,092,088 discloses a sheet-like mat comprised of a mat cover, the inside of which is divided into a plurality of bag-like spaces, and a drying agent packed into a bag and contained in the bag-like spaces in such a manner that the drying agent cannot fall out of the bag-like spaces. A magnesium sulfate, a high polymer absorbent, a silica gel or the like can be used as the drying agent. As can be seen, this proposed solution to moisture in bedding is cumbersome and chemically-based.

In the athletic apparel industry, moisture wicking fabric has been used to construct athletic apparel. For example, United States Patent 5,636,380 discloses a base fabric of CoolmaxQ high moisture evaporation fabric having one or more insulating panels of ThermaxB or ThermastatQ hollow core fiber fabric having moisture wicking capability and applied to the inner side of the garment for skin contact at selected areas of the body where muscle protection is desired. However, this application cannot be applied to bedding sheets due to the limitations of the size of the performance fabrics manufactured. Further, performance fabric such as this type cannot be easily stitched together as the denier is so fine that stitching this fabric results in the stitching simply falling apart.

Circular knitting is typically used for athletic apparel. The process includes circularly knitting yarns into fabrics. Circular knitting is a form of weft knitting where the knitting needles are organized into a circular knitting bed. A cylinder rotates and interacts with a cam to move the needles reciprocally for knitting action. The yarns to be knitted are fed from packages to a carrier plate that directs the yarn strands to the needles. The circular fabric emerges from the knitting needles in a tubular form through the center of the cylinder. This process is described in United States Patent 7,117,695. However, the machinery presently available for this method of manufacture can only produce a fabric with a maximum width of approximately 90 inches. Therefore, this process has not been known to manufacture sheets, since sheets can have dimensions of 91 inches by 102 inches or greater.

Further, the machinery that is used for bedding is very different than for athletic wear. For example, bedding manufacturing equipment is not equipped to sew flatlock stitching or to provide circular knitting. Bed sheets typically are knit using a process known as warp knitting, a

process capable of producing finished fabrics in the widths required for bedding. This method, however, cannot be employed to produce high-quality performance fabrics. Warp knitting is not capable of reproducing these fabrics' fine tactile qualities nor their omni-direction stretch properties, for example.

Circular knitting must be employed to produce a performance fabric that retains these fabric's full range of benefits and advantages. However, in order to produce a fabric of the proper width for bedding applications, a circular knit machine of at least 48 inches in diameter would be necessary. Manufacturing limitations therefore preclude the construction of performance fabrics at proper widths for bedding. The industry is unsure if it could actually knit and then finish performance fabrics at these large sizes, even if the machinery were readily available.

Further, athletic sewing factories are typically not equipped to sew and handle large pieces of fabrics so that equipment limitations do not allow for the manufacture of bedding sheets.

What is needed, therefore, is a bedding system that utilizes performance fabrics and their beneficial properties, the design of which acknowledges and addresses limitations in the manufacture of these fabrics. It is to such a system that the present invention is primarily directed.

BRIEF SUMMARY OF THE INVENTION

Briefly described, in preferred form, the present invention is a high gauge circular knit fabric for use in bedding, and a method for manufacturing such bedding. The bedding fabric has superior performance properties, while allowing for manufacture by machinery presently available and in use. In order to achieve a finished width of the size needed to create sheet-sized performance fabric, a high gauge circular knit machine of at least 48 inches in diameter is necessary. And while warp knitting machines are available that can produce wider fabrics, this method will not provide a fabric with the tactile qualities required, nor provide a fabric with omni-directional stretch.

In an exemplary embodiment, the present invention is a method of making a finished fabric comprising at least two discrete performance fabric portions, and joining at least two

discrete performance fabric portions to form the finished fabric. Forming the at least two discrete performance fabric portions can comprise knitting at least two discrete performance fabric portions, and more preferably, circular knitting at least two discrete performance fabric portions. Joining the at least two discrete performance fabric portions to form the finished fabric can comprise stitching at least two discrete performance fabric portions together to form the finished fabric.

The at least two discrete performance fabric portions can have different fabric characteristics. Fabric characteristics as used herein include, among other things, moisture management, UV protection, anti-microbial, thermo-regulation, wind resistance and water resistance.

The finished fabric can be used in, among other applications, residential settings, or in marine, boating and recreational vehicle environments.

The present sheets offer enhanced drape and comfort compared to traditional cotton bedding, and are as fine as silk, yet provide the benefits of high elasticity and recovery along with superior breathability, body-heat transport, and moisture management as compared to traditional cotton bedding.

Conventional fitted sheets can bunch and slide on standard mattress sizes. Furthermore, if the fitted bed sheets do not fit properly, they do not provide a smooth surface to lie on. The present invention overcomes these issues.

The present high gauge circular knit fabrics stretch to fit and offer superior recovery on the mattress allowing the fabric to conform to fit the mattress without popping off the corners of the mattress or billowing. The performance fabric can include spandex, offers a better fit than conventional bedding products, can accommodate larger or smaller mattress sizes with a single size sheet, and can conform to mattresses with various odd dimensions.

Spandex - or elastane - is a synthetic fiber known for its exceptional elasticity. It is stronger and more durable than rubber, its major non-synthetic competitor. It is a polyurethane-polyurea copolymer that was invented by DuPont. "Spandex" is a generic name, and an anagram of the word "expands." "Spandex" is the preferred name in North America; elsewhere it is

referred to as “elastane.” The most famous brand name associated with spandex is Lycra, a trademark of Invista.

The present high gauge circular knit fabric offers durability in reduced pilling and pulling when compared to other knit technologies, and offer reduced wrinkles and enhanced color steadfastness

In a preferred embodiment, the present performance fabric can allow for a one-size fitted sheet that can actually fit two different size mattresses. For example, the full fitted sheet of the present invention can fit on both the full and queen size bed. The twin fitted sheet of the present invention will also fit an XL twin. In a boating application, the present invention can be produced to fit almost every custom boat mattress.

Testing of the present invention conducted at the North Carolina State University (NCSU) Center for Research on Textile Protection and Comfort confirms that the present performance fabrics provide a cooler sleeping environment than cotton. Performance bedding was tested side-by-side with commercially available cotton bed sheets in a series of procedures designed to measure each product’s heat- and moisture-transport properties, as well as warm/cool-to-touch thermal transport capabilities.

Across all tests, the present performance fabrics in bedding outperformed cotton, demonstrating the performance fabric’s superiority in establishing and maintaining thermal comfort during sleep. This advantage is evident to users from the very onset, as NCSU testing indicates that, on average, performance bedding of the present invention offers improved heat transfer upon initial contact with the skin, resulting in a cooler-to-the-touch feeling.

During sleep, high gauge circular knit performance bedding of the present invention helps to maintain thermal comfort by trapping less body heat and breathing better than cotton. Testing has demonstrated that performance bedding made out of performance fabrics transfers heat away from the body up to two times more effectively than cotton. This is critically important not only for sustained comfort during sleep, but also in terms of enabling the body to cool itself as rapidly as possible to facilitate sleep onset. In addition to trapping less heat, performance bedding breathes better than cotton – up to 50% better, giving performance bedding a strong advantage in terms of ventilation and heat and moisture transfer.

The performance advantage over cotton holds true for simulated dry and wet skin conditions, confirming that certain performance fabrics in bedding are better suited than cotton at managing moisture (e.g., sweat) to maintain thermal comfort. In addition to wicking moisture away from the skin through capillary action, the performance fabric's advanced breathability further enables heat and moisture transfer through evaporative cooling. As a result, the user is kept cooler, drier and more comfortable than with cotton.

The present performance bedding holds a distinct advantage over cotton in enabling, accommodating and maintaining optimum thermal conditions for sleep, which in turn can lead to faster sleep initiation and deeper, more restorative sleep.

These and other objects, features and advantages of the present invention will become more apparent upon reading the following specification in conjunction with the accompanying drawings.

BRIEF DESCRIPTION OF THE FIGURES

Fig. 1 illustrates a preferred embodiment of the present invention.

Fig. 2 illustrates another preferred embodiment of the present invention.

Fig. 3 illustrates a further preferred embodiment of the present invention.

Fig. 4 illustrates another preferred embodiment of the present invention.

DETAILED DESCRIPTION OF PREFERRED EMBODIMENTS

Although preferred embodiments of the invention are explained in detail, it is to be understood that other embodiments are contemplated. Accordingly, it is not intended that the invention is limited in its scope to the details of construction and arrangement of components set forth in the following description or illustrated in the drawings. The invention is capable of other embodiments and of being practiced or carried out in various ways. Also, in describing the preferred embodiments, specific terminology will be resorted to for the sake of clarity.

It must also be noted that, as used in the specification and the appended claims, the singular forms "a," "an" and "the" include plural referents unless the context clearly dictates otherwise. For example, reference to a sheet or portion is intended also to include the

manufacturing of a plurality of sheets or portions. References to a sheet containing “a” constituent is intended to include other constituents in addition to the one named.

Also, in describing the preferred embodiments, terminology will be resorted to for the sake of clarity. It is intended that each term contemplates its broadest meaning as understood by those skilled in the art and includes all technical equivalents which operate in a similar manner to accomplish a similar purpose.

Ranges may be expressed herein as from “about” or “approximately” one particular value and/or to “about” or “approximately” another particular value. When such a range is expressed, another embodiment includes from the one particular value and/or to the other particular value.

By “comprising” or “containing” or “including” is meant that at least the named compound, element, particle, or method step is present in the composition or article or method, but does not exclude the presence of other compounds, materials, particles, method steps, even if the other such compounds, material, particles, method steps have the same function as what is named.

It is also to be understood that the mention of one or more method steps does not preclude the presence of additional method steps or intervening method steps between those steps expressly identified. Similarly, it is also to be understood that the mention of one or more components in a fabric or system does not preclude the presence of additional components or intervening components between those components expressly identified.

Referring now in detail to the drawing figures, wherein like reference numerals represent like parts throughout the several views, the present invention of **Figs. 1 and 4** provides a sheet **10** shown having dimensions of 102 inches in length and 91 inches in width. The material is manufactured from performance fabric, which can include, for example, varying amounts of one or more of Lycra, Coolmax, Thermax and Thermastat. In a preferred embodiment, the fabric is treated so that the fabric has antimicrobial properties. By using circular-knit performance fabric, the fabric is able to provide elasticity in all four directions. This property allows for the sheet to fit extraordinary mattress, cushion and bedding shapes, as well as providing better fits for traditional rectangular sheets. By using performance fabrics, the sheet has elastic properties that allow stretching in the directions shown as **30**. In addition, by using circular-knit performance

fabric, the resulting bedding retains an exceptionally fine tactile quality critical for providing maximum levels of enhanced comfort.

An alternative to circular knitting is non-circular knitting – for example, warp knitting. This method can achieve widths greater than circular knitting. Industrial warp knit machines, for example, can produce tricote warp knit fabrics up to 130-140 inches in width. Circular knitting, however, is less expensive, as it requires less set-up time. Circular knitting also provides greater multidirectional stretch.

In order to provide a sheet that exceeds the maximum dimensions of fabric that can be produced by available circular knitting machines, flat lock stitching **12** is used to join a plurality of portions resulting in a sheet that is 91 inches wide (as shown). In an exemplary embodiment, piping **11** can be included in close proximity to the stitching. The stitching can be the same color as the fabric of the sheet portions, or different color(s). The piping can be 3/4 inch straight piping without a cord or other filler. In one preferred embodiment, the stitching is 16 stitches per inch. Piping **11** can be included at one end of the sheet and can be the same or a different color as the sheet fabric.

For a fitted sheet, the sheet can include an elastic portion surrounding the edge of the fitted sheet to better keep the fitted sheet in place when placed on a mattress or other sleeping surface. A cord can be sewn into the edge of the fitted sheet and cinched around the mattress or other sleeping surface to better hold the fitted sheet in place.

Referring to **Fig. 2**, a sheet is shown having dimensions of 91 inches wide and 102 inches in length. In this embodiment, stitching **14** is shown 34 inches from an interior edge **18** of a main portion **16** and another stitch **14** at edge **20** of the sewn-on portion. Flat lock stitching can be used for the stitching. Piping can be applied at or in proximity to the stitching.

Referring to **Fig. 3**, a non-rectangular shaped sheet is shown. In this exemplary embodiment, elastic can be included around the edge of the fitted sheet to better maintain the fitted sheet in position when placed on a sleeping surface. In one embodiment, pull ties **24** can be installed at various locations around the edge of the fitted sheet in order to assist in maintaining the fitted sheet secured to the sleeping surface. The pull tie can be cinched to increase tension around the edge of the fitted sheet as shown by **26**.

Stitching used for securing the portions of the sheet together can include that shown as **28a**. In another embodiment, the stitching used for securing the portion of fabric together is shown as **28b**.

Referring to **Fig. 4**, yet another preferred embodiment of the invention is shown. In this embodiment, the sheet can be assembled through stitching of differing fabrics for generating performance zones in the sheet. For example, zone **32** can have higher wicking properties than the other zones since this area is where the majority of the individual body rests. Areas **34a** through **34d** can have higher spandex or other elastic fabric properties so that the fit around a sleeping surface is improved. Area **36** may have thermal properties such as increased cooling since this area is generally where the individual's head lies. In an exemplary embodiment, the pillow covers of pillows used by the individual also have differing properties from the remainder of the sheet, e.g., thermal properties.

The present invention encompasses the construction of bedding materials that have superior performance properties while allowing for manufacture by machinery presently available and in use. More specifically, the invention is related to a new method for fabricating a covering and or sheets in bedding. When using the circular knitting machine, the high gauge performance fabrics can only be made to a maximum size of 72.5 inches without losing the integrity of the spandex in the fabric. Yet, normal sheet panels are 102 x 91 inches. This presents problems when manufacturing sheets from performance fabrics.

Additionally, special stitching techniques must be used given the thread density of the fabric. Using this special stitching, panels are sewn together to produce bedding or a sheet that is the proper size for standard bed sheets. Because discrete portions/panels are used in the manufacture of the present fabrics, panels can be selected that provide different properties for different areas of the bedding (**Fig. 4**). Stitching or seams on the sheet can also allow for the ease of making the bed. Because the bedding is made from performance fabric with spandex, it stretches to permit multiple and custom sizing for applications in cribs, recreational vehicles and boats.

Circular knitting machines used for high gauge performance bedding fabrics are called high-gauge circular knitting machines, because of dense knitting with thin yarn. High gauge generally denotes 17 gauges or more. Seventeen gauges indicate that 17 or more cylinder

needles are contained in one inch. Circular knitting machines of less than 17 gauges are referred to as low-gauge circular knitting machines. The low-gauge circular knitting machines are often used to knit outerwear.

“Yarn count” indicates the linear density (yarn diameter or fineness) to which that particular yarn has been spun. The choice of yarn count is restricted by the type of knitting machine employed and the knitting construction. The yarn count, in turn, influences the cost, weight, opacity, hand and drape of the resulting knitted structure. In general, staple spun yarns tend to be comparatively more expensive the finer their count, because finer fibers and a more exacting spinning process are necessary in order to prevent the yarn from showing an irregular appearance.

A top width in the 90-inch range is currently possible using a circular knit fabric formed on a 36-38-inch diameter machine, although higher levels of spandex in the performance fabric tend to pull the width in. In just one example, on a 30-inch diameter machine, the spandex can reduce an otherwise 94-inch circumference fabric tube to one with a 60-65 inch finished width.

A major limitation in finished width is not strictly a knitting concern but also concerns finishing. With performance fabric, it tends to sag in the middle – increasingly so with greater widths – making finishing difficult to impossible above a certain threshold. A possible 90-inch finished width is contingent upon having a good finishing set-up capable of handling the present performance fabric. This potential for difficulties would only become compounded at the larger widths required for bed sheets.

In a preferred process, the present fabric undergoes a heat setting finishing process. Applying a moisture-wicking finish to another fabric – like cotton – that can be produced at larger widths appears unlikely to match the moisture-control properties of the present fabric, as polyester itself is naturally moisture-resistant and there are physical actions (e.g. capillary action) at play. Further, the use of cotton comes at the expense of breathability and heat-transfer capabilities (as confirmed by laboratory testing) and stretchability.

Numerous characteristics and advantages have been set forth in the foregoing description, together with details of structure and function. While the invention has been disclosed in several forms, it will be apparent to those skilled in the art that many modifications, additions, and deletions, especially in matters of shape, size, and arrangement of parts, can be made therein

without departing from the spirit and scope of the invention and its equivalents as set forth in the following claims. Therefore, other modifications or embodiments as may be suggested by the teachings herein are particularly reserved as they fall within the breadth and scope of the claims here appended.

CLAIMS

What is claimed is:

1. A method of making a finished fabric at least 90 inches wide comprising:
forming at least two discrete performance fabric portions; and
joining at least two discrete performance fabric portions to form the finished fabric.
2. The method according to Claim 1, wherein forming at least two discrete performance fabric portions comprises knitting at least two discrete performance fabric portions.
3. The method according to Claim 1, wherein forming at least two discrete performance fabric portions comprises circular knitting at least two discrete performance fabric portions.
4. The method according to Claim 1, wherein joining at least two discrete performance fabric portions to form the finished fabric comprises stitching at least two discrete performance fabric portions together to form the finished fabric.
5. A method of making a finished fabric at least 90 inches wide comprising:
circular knitting at least two discrete performance fabric portions; and
stitching at least two discrete performance fabric portions together to form the finished fabric.
6. The method according to Claim 5, wherein the finished fabric comprises a bed sheet.
7. The method according to Claim 5, further comprising heat setting finishing the finished fabric.
8. The method according to Claim 5, further comprising providing piping to the finished fabric.
9. A method of making a bed sheet at least 90 inches wide from performance fabric comprising:
circular knitting at least two discrete performance fabric portions;
stitching at least two discrete performance fabric portions together; and

heat setting finishing the stitched at least two discrete performance fabric portions to form the finished bed sheet.

10. The method according to Claim 9, further comprising providing piping to the finished bed sheet.

11. The method according to Claim 9, wherein the at least two discrete performance fabric portions have different fabric characteristics.

12. The method according to Claim 11, wherein fabric characteristics are selected from the group consisting of moisture management, UV protection, anti-microbial, thermo-regulation, wind resistance and water resistance.

13. A finished fabric at least 90 inches wide comprising:

a first circular knitted performance fabric; and

a second circular knitted performance fabric;

wherein the first and second performance fabrics are discrete; and

wherein the first and second performance fabrics are joined to form the finished fabric.

14. The finished fabric of Claim 13, wherein the finished fabric comprises a bed sheet.

15. The finished fabric of Claim 13, further comprising piping.

16. The finished fabric of Claim 13, wherein the first and second performance fabrics have different fabric characteristics.

17. The finished fabric of Claim 16, wherein fabric characteristics are selected from the group consisting of moisture management, UV protection, anti-microbial, thermo-regulation, wind resistance and water resistance.

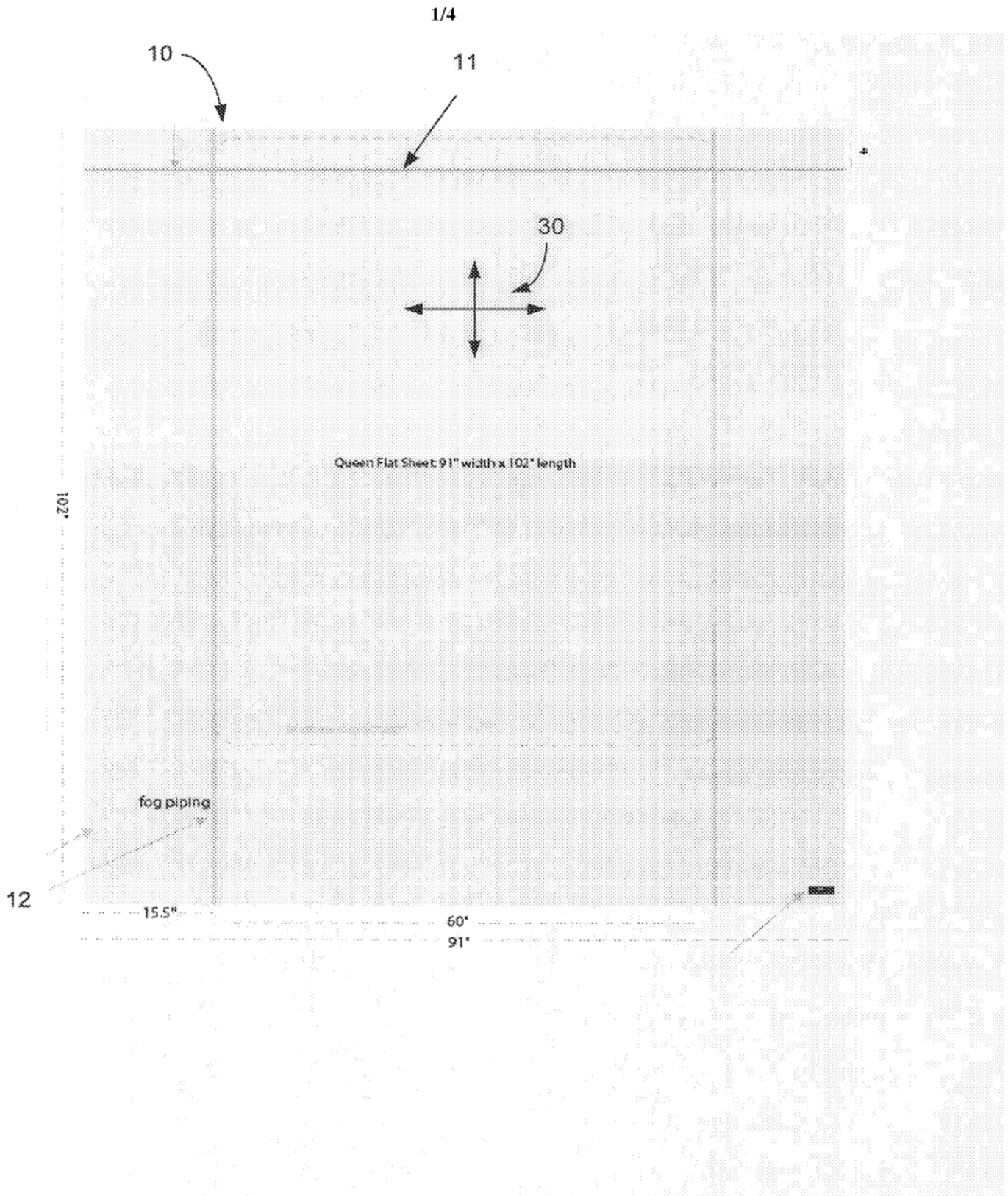

Fig. 1

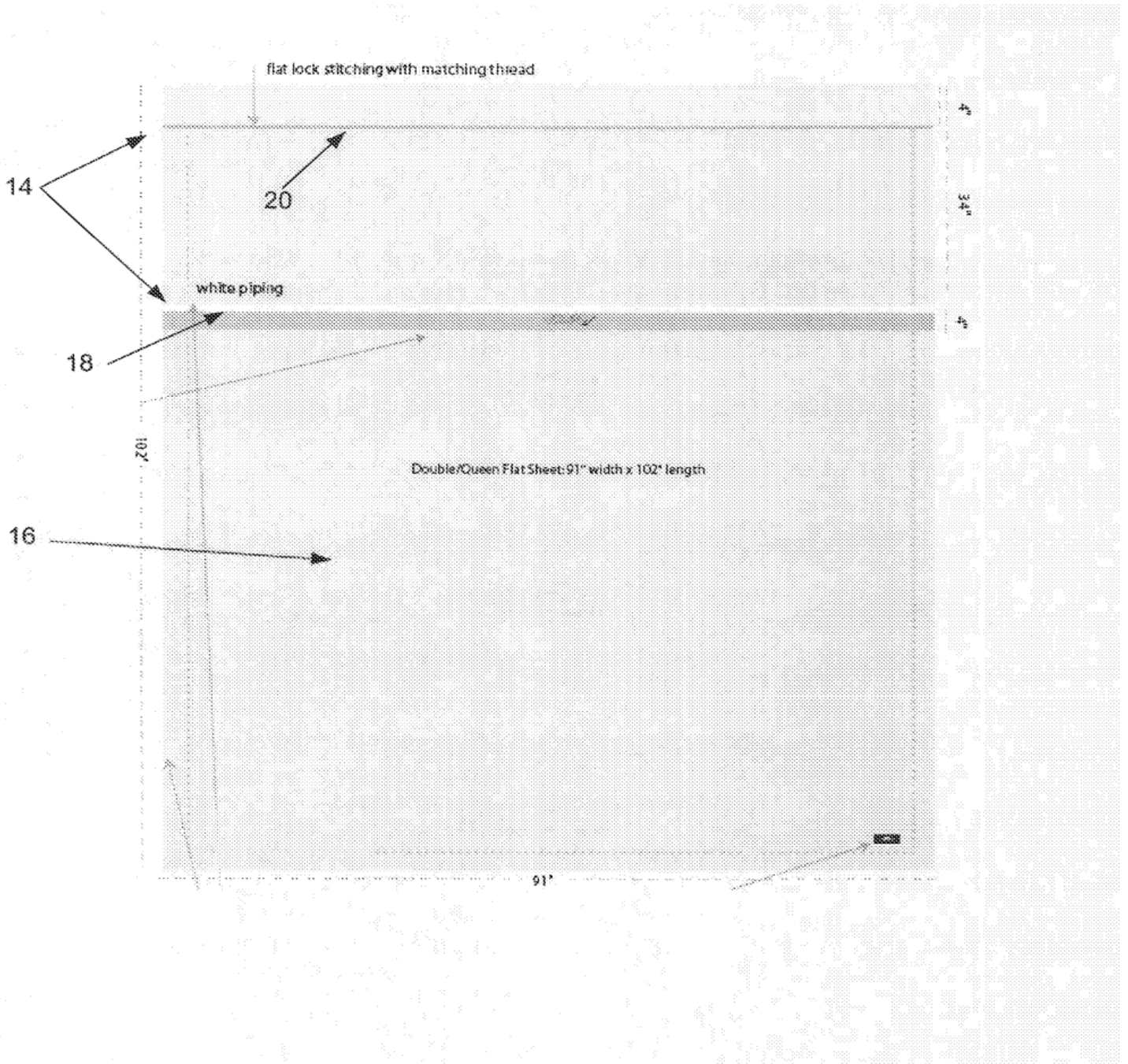

Fig. 2

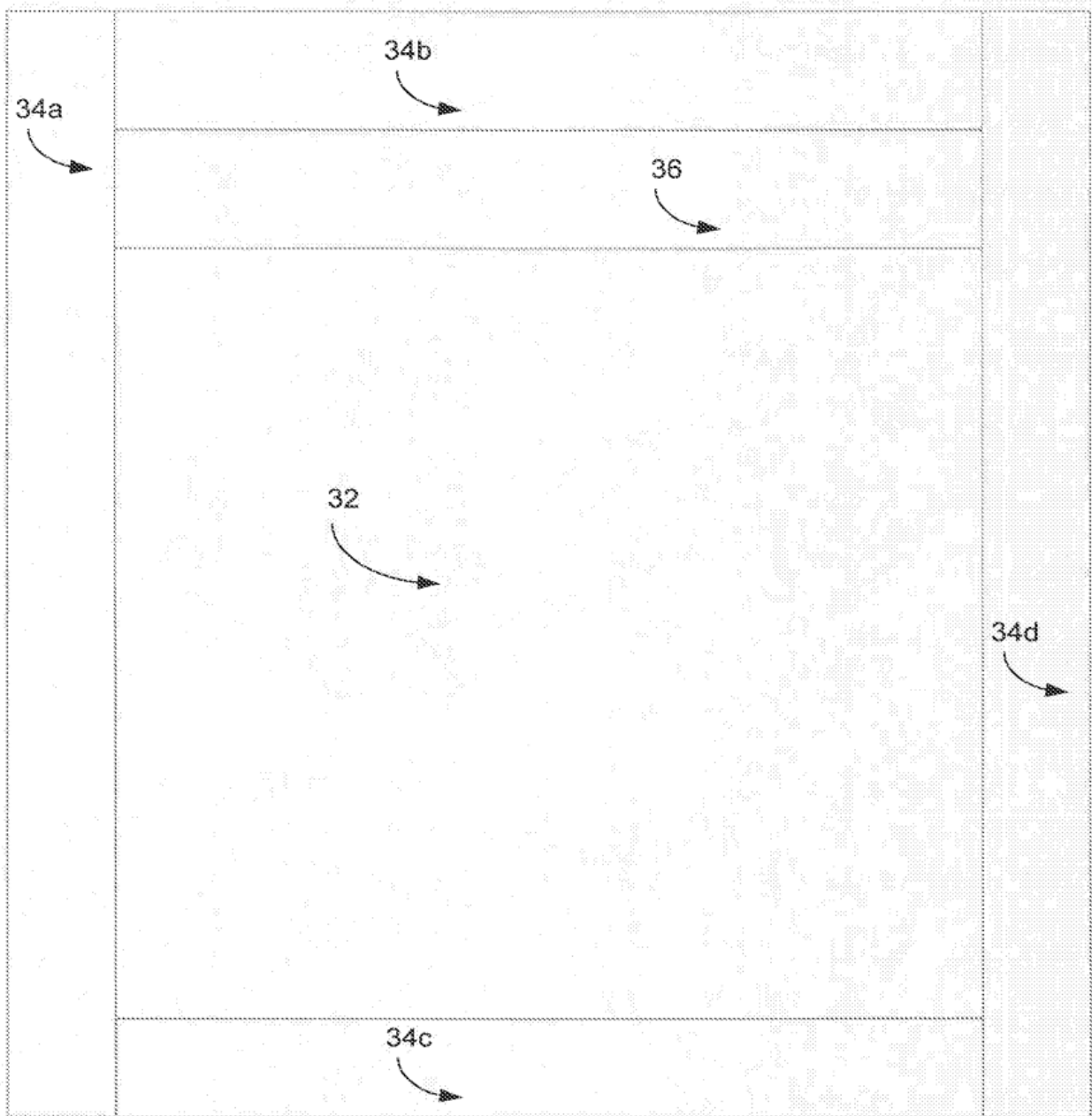

Fig. 4

(19) World Intellectual Property Organization
International Bureau



(43) International Publication Date
1 April 2010 (01.04.2010)

(10) International Publication Number
WO 2010/037082 A3

- (51) International Patent Classification:
D04B 21/14 (2006.01) *D03D 11/00* (2006.01)
- (21) International Application Number:
PCT/US2009/058716
- (22) International Filing Date:
29 September 2009 (29.09.2009)
- (25) Filing Language: English
- (26) Publication Language: English
- (30) Priority Data:
61/101,049 29 September 2008 (29.09.2008) US
- (71) Applicant (for all designated States except US): **SHEEX LLC** [US/US]; 169 Captain Lowman Road, Chapin, SC 29036 (US).
- (72) Inventors; and
- (75) Inventors/Applicants (for US only): **WALVIUS, Susan, Katherine** [US/US]; 169 Captain Lowman Road, Chapin, SC 29036 (US). **MARCINIAK, Michelle, Marie** [US/US]; 169 Captain Lowman Road, Chapin, SC 29036 (US).
- (74) Agent: **SCHNEIDER, Ryan, A.**; Troutman Sanders LLP, Bank of America Plaza, 600 Peachtree Street, N.E., Suite 5200, Atlanta, GA 30308-2216 (US).

- (81) Designated States (unless otherwise indicated, for every kind of national protection available): AE, AG, AL, AM, AO, AT, AU, AZ, BA, BB, BG, BH, BR, BW, BY, BZ, CA, CH, CL, CN, CO, CR, CU, CZ, DE, DK, DM, DO, DZ, EC, EE, EG, ES, FI, GB, GD, GE, GH, GM, GT, HN, HR, HU, ID, IL, IN, IS, JP, KE, KG, KM, KN, KP, KR, KZ, LA, LC, LK, LR, LS, LT, LU, LY, MA, MD, ME, MG, MK, MN, MW, MX, MY, MZ, NA, NG, NI, NO, NZ, OM, PE, PG, PH, PL, PT, RO, RS, RU, SC, SD, SE, SG, SK, SL, SM, ST, SV, SY, TJ, TM, TN, TR, TT, TZ, UA, UG, US, UZ, VC, VN, ZA, ZM, ZW.
- (84) Designated States (unless otherwise indicated, for every kind of regional protection available): ARIPO (BW, GH, GM, KE, LS, MW, MZ, NA, SD, SL, SZ, TZ, UG, ZM, ZW), Eurasian (AM, AZ, BY, KG, KZ, MD, RU, TJ, TM), European (AT, BE, BG, CH, CY, CZ, DE, DK, EE, ES, FI, FR, GB, GR, HR, HU, IE, IS, IT, LT, LU, LV, MC, MK, MT, NL, NO, PL, PT, RO, SE, SI, SK, SM, TR), OAPI (BF, BJ, CF, CG, CI, CM, GA, GN, GQ, GW, ML, MR, NE, SN, TD, TG).

- Published:**
- with international search report (Art. 21(3))
 - before the expiration of the time limit for amending the claims and to be republished in the event of receipt of amendments (Rule 48.2(h))

[Continued on next page]

(54) Title: FABRIC SYSTEM

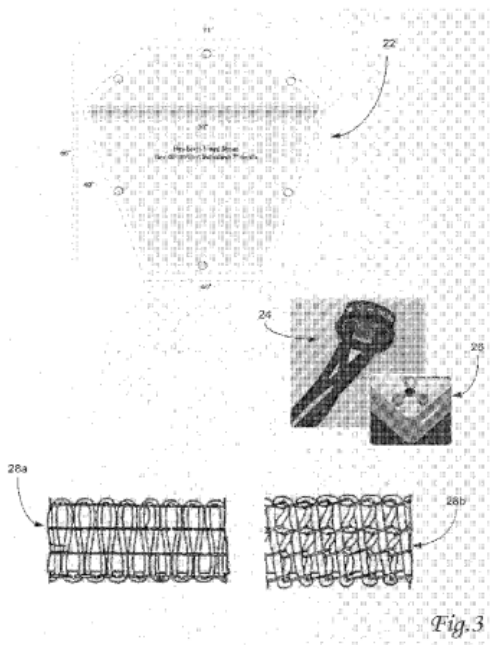

(57) Abstract: Bedding material including a first fabric section manufactured from performance fabric and having a first and second side; and, a second fabric section attached to the first side of the first fabric section. Additionally, a third fabric section can be attached to the second side of the first fabric section. The first fabric section can be attached to the second fabric section through a flatlock stitch. The first fabric section can include a first zone and a second zone wherein the first zone contains different performance properties from the second zone and the first zone can have thermal or moisture wicking properties.



WO 2010/037082 A3

(88) Date of publication of the international search report:
8 July 2010

A. CLASSIFICATION OF SUBJECT MATTER***D04B 21/14(2006.01)i, D03D 11/00(2006.01)i***

According to International Patent Classification (IPC) or to both national classification and IPC

B. FIELDS SEARCHED

Minimum documentation searched (classification system followed by classification symbols)

D04B 21/14; A47G 9/00; A47G 9/02; A61G 7/05; B32B 5/26

Documentation searched other than minimum documentation to the extent that such documents are included in the fields searched

Korean utility models and applications for utility models
Japanese utility models and applications for utility models
(Chinese Patents and application for patent)Electronic data base consulted during the international search (name of data base and, where practicable, search terms used)
eKOMPASS(KIPO internal)**C. DOCUMENTS CONSIDERED TO BE RELEVANT**

Category*	Citation of document, with indication, where appropriate, of the relevant passages	Relevant to claim No.
X	JP 11-309183 A (MORIUCHI KYU KK) 09 November 1999 See paragraphs [0001] and [0010]-[0013]	1-17
X	US 6381779 B1 (THOMPSON; THOMAS L.) 07 May 2002 See claim 1 and figures 4-6	1
A	US 5817391 A1 (ROCK; MOSHE et al.) 06 October 1998 See column 1, line 66 - column 3, line 19	1-17
A	US 5765241 A1 (MACDONALD; ROBERT) 16 June 1998 See the whole document	1-17

 Further documents are listed in the continuation of Box C. See patent family annex.

* Special categories of cited documents:

"A" document defining the general state of the art which is not considered to be of particular relevance

"E" earlier application or patent but published on or after the international filing date

"L" document which may throw doubts on priority claim(s) or which is cited to establish the publication date of citation or other special reason (as specified)

"O" document referring to an oral disclosure, use, exhibition or other means

"P" document published prior to the international filing date but later than the priority date claimed

"T" later document published after the international filing date or priority date and not in conflict with the application but cited to understand the principle or theory underlying the invention

"X" document of particular relevance; the claimed invention cannot be considered novel or cannot be considered to involve an inventive step when the document is taken alone

"Y" document of particular relevance; the claimed invention cannot be considered to involve an inventive step when the document is combined with one or more other such documents, such combination being obvious to a person skilled in the art

"&" document member of the same patent family

Date of the actual completion of the international search

28 APRIL 2010 (28.04.2010)

Date of mailing of the international search report

29 APRIL 2010 (29.04.2010)

Name and mailing address of the ISA/KR

Korean Intellectual Property Office
Government Complex-Daejeon, 139 Seonsa-ro, Seo-
gu, Daejeon 302-701, Republic of Korea

Facsimile No. 82-42-472-7140

Authorized officer

KIM, Jong Kyoo

Telephone No. 82-42-481-5593



INTERNATIONAL SEARCH REPORT

Information on patent family members

International application No.

PCT/US2009/058716

Patent document cited in search report	Publication date	Patent family member(s)	Publication date
JP 11-309183 A	09.11.1999	None	
US 6381779 B1	07.05.2002	US 6678906 B1 WO 0309-2452A1	20.01.2004 13.11.2003
US 5817391 A1	06.10.1998	None	
US 5765241 A1	16.06.1998	AU 1997-12445 B2 EP 0787451 A2 EP 0787451 A3 EP 0787451 B1 GB 2309638 A	27.05.1999 06.08.1997 13.10.1999 04.06.2003 06.08.1997

ADVANCE E-MAIL

From the INTERNATIONAL BUREAU

PCT

NOTIFICATION CONCERNING
TRANSMITTAL OF COPY OF INTERNATIONAL
PRELIMINARY REPORT ON PATENTABILITY
(CHAPTER I OF THE PATENT COOPERATION
TREATY)
(PCT Rule 44bis.1(c))

To:

SCHNEIDER, Ryan, A.
Troutman Sanders LLP
Bank of America Plaza
600 Peachtree Street, N.E.
Suite 5200
Atlanta, GA 30308-2216
ETATS-UNIS D'AMERIQUE

Date of mailing <i>(day/month/year)</i> 07 April 2011 (07.04.2011)		
Applicant's or agent's file reference SHEEX1PCT		IMPORTANT NOTICE
International application No. PCT/US2009/058716	International filing date <i>(day/month/year)</i> 29 September 2009 (29.09.2009)	Priority date <i>(day/month/year)</i> 29 September 2008 (29.09.2008)
Applicant SHEEX LLC et al		

The International Bureau transmits herewith a copy of the international preliminary report on patentability (Chapter I of the Patent Cooperation Treaty)

The International Bureau of WIPO 34, chemin des Colombettes 1211 Geneva 20, Switzerland Facsimile No. +41 22 338 82 70	Authorized officer <p style="text-align: center;">Beate Giffo-Schmitt</p> e-mail: pt03.pct@wipo.int
---	---

PATENT COOPERATION TREATY

PCT

INTERNATIONAL PRELIMINARY REPORT ON PATENTABILITY

(Chapter I of the Patent Cooperation Treaty)

(PCT Rule 44*bis*)

Applicant's or agent's file reference SHEEX1PCT	FOR FURTHER ACTION		See item 4 below
International application No. PCT/US2009/058716	International filing date (<i>day/month/year</i>) 29 September 2009 (29.09.2009)	Priority date (<i>day/month/year</i>) 29 September 2008 (29.09.2008)	
International Patent Classification (8th edition unless older edition indicated) See relevant information in Form PCT/ISA/237			
Applicant SHEEX LLC			

1. This international preliminary report on patentability (Chapter I) is issued by the International Bureau on behalf of the International Searching Authority under Rule 44 *bis*.1(a).

2. This REPORT consists of a total of 5 sheets, including this cover sheet.

In the attached sheets, any reference to the written opinion of the International Searching Authority should be read as a reference to the international preliminary report on patentability (Chapter I) instead.

3. This report contains indications relating to the following items:

<input checked="" type="checkbox"/>	Box No. I	Basis of the report
<input type="checkbox"/>	Box No. II	Priority
<input type="checkbox"/>	Box No. III	Non-establishment of opinion with regard to novelty, inventive step and industrial applicability
<input type="checkbox"/>	Box No. IV	Lack of unity of invention
<input checked="" type="checkbox"/>	Box No. V	Reasoned statement under Article 35(2) with regard to novelty, inventive step or industrial applicability; citations and explanations supporting such statement
<input type="checkbox"/>	Box No. VI	Certain documents cited
<input type="checkbox"/>	Box No. VII	Certain defects in the international application
<input type="checkbox"/>	Box No. VIII	Certain observations on the international application

4. The International Bureau will communicate this report to designated Offices in accordance with Rules 44*bis*.3(c) and 93*bis*.1 but not, except where the applicant makes an express request under Article 23(2), before the expiration of 30 months from the priority date (Rule 44*bis* .2).

The International Bureau of WIPO 34, chemin des Colombettes 1211 Geneva 20, Switzerland Facsimile No. +41 22 338 82 70	Date of issuance of this report 29 March 2011 (29.03.2011)
	Authorized officer <p align="center">Beate Giffo-Schmitt</p> e-mail: pt03.pct@wipo.int

Form PCT/IB/373 (January 2004)

PATENT COOPERATION TREATY

From the
INTERNATIONAL SEARCHING AUTHORITY

PCT

**WRITTEN OPINION OF THE
INTERNATIONAL SEARCHING AUTHORITY**

(PCT Rule 43bis.1)

To: SCHNEIDER RYAN A. TROUTMAN SANDERS LLP BANK OF AMERICA PLAZA 600 PEACHTREE STREET, N.E., SUITE 5200 ATLANTA GA 30308-2216 USA

Date of mailing (day/month/year) 29 APRIL 2010 (29.04.2010)

Applicant's or agent's file reference SHEEX1PCT	FOR FURTHER ACTION See paragraph 2 below
--	--

International application No. PCT/US2009/058716	International filing date (day/month/year) 29 SEPTEMBER 2009 (29.09.2009)	Priority date(day/month/year) 29 SEPTEMBER 2008 (29.09.2008)
---	---	---

International Patent Classification (IPC) or both national classification and IPC D04B 21/14(2006.01)i, D03D 11/00(2006.01)i
--

Applicant SHEEX LLC et al



1. This opinion contains indications relating to the following items:
- Box No. I Basis of the opinion
 - Box No. II Priority
 - Box No. III Non-establishment of opinion with regard to novelty, inventive step and industrial applicability
 - Box No. IV Lack of unity of invention
 - Box No. V Reasoned statement under Rule 43bis.1(a)(i) with regard to novelty, inventive step or industrial applicability; citations and explanations supporting such statement
 - Box No. VI Certain documents cited
 - Box No. VII Certain defects in the international application
 - Box No. VIII Certain observations on the international application

2. **FURTHER ACTION**

If a demand for international preliminary examination is made, this opinion will be considered to be a written opinion of the International Preliminary Examining Authority ("IPEA") except that this does not apply where the applicant chooses an Authority other than this one to be the IPEA and the chosen IPEA has notified the International Bureau under Rule 66.1bis(b) that written opinions of this International Searching Authority will not be so considered.

If this opinion is, as provided above, considered to be a written opinion of the IPEA, the applicant is invited to submit to the IPEA a written reply together, where appropriate, with amendments, before the expiration of 3 months from the date of mailing of Form PCT/ISA/220 or before the expiration of 22 months from the priority date, whichever expires later.
For further options, see Form PCT/ISA/220.

3. For further details, see notes to Form PCT/ISA/220.

 Name and mailing address of the ISA/KR Korean Intellectual Property Office Government Complex-Daejeon, 139 Seonsa-ro, Seo-gu, Daejeon 302 -701, Republic of Korea Facsimile No. 82-42-472-7140	Date of completion of this opinion 28 APRIL 2010 (28.04.2010)	Authorized officer KIM, Jong Kyoo Telephone No.82-42-481-5593	
---	--	---	---

**WRITTEN OPINION OF THE
INTERNATIONAL SEARCHING AUTHORITY**

International application No.

PCT/US2009/058716

Box No. I Basis of this opinion

1. With regard to the **language**, this opinion has been established on the basis of:
 - the international application in the language in which it was filed
 - a translation of the international application into _____, which is the language of a translation furnished for the purposes of international search (Rules 12.3(a) and 23.1(b))
2. This opinion has been established taking into account the **rectification of an obvious mistake** authorized by or notified to this Authority under Rule 91 (Rule 43bis.1(a))
3. With regard to any **nucleotide and/or amino acid sequence** disclosed in the international application, this opinion has been established on the basis of:
 - a. a sequence listing filed or furnished
 - on paper
 - in electronic form
 - b. time of filing or furnishing
 - contained in the international application as filed.
 - filed together with the international application in electronic form.
 - furnished subsequently to this Authority for the purposes of search.
4. In addition, in the case that more than one version or copy of a sequence listing has been filed or furnished, the required statements that the information in the subsequent or additional copies is identical to that in the application as filed or does not go beyond the application as filed, as appropriate, were furnished.
5. Additional comments:

**WRITTEN OPINION OF THE
INTERNATIONAL SEARCHING AUTHORITY**

International application No.

PCT/US2009/058716

Box No. V Reasoned statement under Rule 43bis.1(a)(i) with regard to novelty, inventive step or industrial applicability; citations and explanations supporting such statement

1. Statement

Novelty (N)	Claims	<u>1-17</u>	YES
	Claims	<u>NONE</u>	NO
Inventive step (IS)	Claims	<u>NONE</u>	YES
	Claims	<u>1-17</u>	NO
Industrial applicability (IA)	Claims	<u>1-17</u>	YES
	Claims	<u>NONE</u>	NO

2. Citations and explanations :

Reference is made to the following document :

D1: JP 11-309183 A (MORIUCHI KYU KK) 09 November 1999

1. Novelty and Inventive Step

1-1. Regarding claims 1-4

Most of the features of claim 1 are disclosed in D1 except for making the finished fabric at least 90 inches wide. However, it is considered to be a minor difference over the disclosure of D1, that are merely matters of design option when the general knowledge in relevant field of the art is used. Hence, no inventive step under PCT Article 33(3) is present in the subject matter of claim 1.

The additional feature of claim 2 is already disclosed in D1(see claim 3). The features added by claims 3 & 4 are considered to be a minor difference over the disclosure of D1(see paragraphs [0010]-[0013]), which fall under the general knowledge of a person skilled in the art. Hence, no inventive step under PCT Article 33(3) is present in the subject matter of claims 2-4.

1-2. Regarding claims 5-8

Most of the features of claim 5 are disclosed in D1 except for making the finished fabric at least 90 inches wide, circular knitting the fabric and stitching the fabric portions together. However, making the finished fabric at least 90 inches wide is considered to be a minor difference over the disclosure of D1, that is merely matters of design option when the general knowledge in relevant field of the art is used. Circular knitting and stitching are considered to be a minor difference over the disclosure of D1(see paragraphs [0010]-[0013]), which fall under the general knowledge of a person skilled in the art. Hence, no inventive step under PCT Article 33(3) is present in the subject matter of claim 5.

The additional feature of claim 6 is already disclosed in D1(see paragraph [0001]). The features added by claims 7 & 8 are a simple addition of conventional technique in this field as occasion demands. Hence, no inventive step under PCT Article 33(3) is present in the subject matter of claims 6-8.

1-3. Regarding claims 9-12

Most of the features of claim 9 are disclosed in D1 except for making the bed sheet at least 90 inches wide, circular knitting the fabric, stitching the fabric portions together and heat setting finishing. However, making the bed sheet at least 90 inches wide is considered to be a minor difference over the disclosure of D1, that is merely matters of design option when the general knowledge in relevant field of the art is used. Circular knitting and stitching are considered to be a minor difference over the disclosure of D1(see paragraphs [0010]-[0013]), which fall under the general knowledge of a person skilled in the art. Heat setting finishing without limitation of kinds of the material of the fiber is a simple addition of conventional technique as occasion demands. Hence, no inventive step under PCT Article 33(3) is present in the subject matter of claim 9.

Continued on Supplemental Box

Supplemental Box

In case the space in any of the preceding boxes is not sufficient.

Continuation of :

Box V

The feature added by claim 10 is a simple addition of conventional technique in this field as occasion demands. The additional features of claims 11 & 12 are already disclosed in D1(see paragraph [0010]-[0013]). Hence, no inventive step under PCT Article 33(3) is present in the subject matter of claims 10-12.

1-4. Regarding claims 13-17

Most of the features of claim 13 are disclosed in D1 except for the finished fabric at least 90 inches wide and the circular knitted fabric. However, the finished fabric at least 90 inches wide is considered to be a minor difference over the disclosure of D1, that is merely matters of design option when the general knowledge in relevant field of the art is used. Circular knitted fabric is considered to be a minor difference over the disclosure of D1(see paragraphs [0010]-[0013]), which fall under the general knowledge of a person skilled in the art. Hence, no inventive step under PCT Article 33(3) is present in the subject matter of claim 13.

The feature added by claim 15 is a simple addition of conventional technique in this field as occasion demands. The additional features of claims 14, 16 & 17 are already disclosed in D1(see paragraph [0010]-[0013]). Hence, no inventive step under PCT Article 33(3) is present in the subject matter of claims 14-17.

2. Industrial Applicability

The subject matter of claims 1-17 is industrially applicable meeting the requirements of Article 33(4) PCT.

PATENT COOPERATION TREATY

PCT

INTERNATIONAL SEARCH REPORT

(PCT Article 18 and Rules 43 and 44)

Applicant's or agent's file reference SHEEX1PCT	FOR FURTHER ACTION see Form PCT/ISA/220 as well as, where applicable, item 5 below.	
International application No. PCT/US2009/058716	International filing date (<i>day/month/year</i>) 29 SEPTEMBER 2009 (29.09.2009)	(Earliest) Priority Date (<i>day/month/year</i>) 29 SEPTEMBER 2008 (29.09.2008)
Applicant SHEEX LLC et al		

This International search report has been prepared by this International Searching Authority and is transmitted to the applicant according to Article 18. A copy is being transmitted to the International Bureau.

This international search report consists of a total of 3 sheets.

It is also accompanied by a copy of each prior art document cited in this report.

1. **Basis of the report**

a. With regard to the language, the international search was carried out on the basis of:

the international application in the language in which it was filed

a translation of the international application into _____, which is the language of a translation furnished for the purposes of international search (Rules 12.3(a) and 23.1(b))

b. This international search report has been established taking into account the **rectification of an obvious mistake** authorized by or notified to this Authority under Rule 91 (Rule 43.6bis(a)).

c. With regard to any **nucleotide and/or amino acid sequence** disclosed in the international application, see Box No. I.

2. **Certain claims were found unsearchable** (See Box No. II)

3. **Unity of invention is lacking** (See Box No. III)

4. With regard to the title,

the text is approved as submitted by the applicant.

the text has been established by this Authority to read as follows:

5. With regard to the abstract,

the text is approved as submitted by the applicant.

the text has been established, according to Rule 38.2, by this Authority as it appears in Box No. IV. The applicant may, within one month from the date of mailing of this international search report, submit comments to this Authority.

6. With regard to the drawings,

a. the figure of the drawings to be published with the abstract is Figure No. 3

as suggested by the applicant.



as selected by this Authority, because the applicant failed to suggest a figure.

as selected by this Authority, because this figure better characterizes the invention.

b. none of the figure is to be published with the abstract.

INTERNATIONAL SEARCH REPORT

International application No.
PCT/US2009/058716

A. CLASSIFICATION OF SUBJECT MATTER		
<i>D04B 21/14(2006.01)i, D03D 11/00(2006.01)i</i>		
According to International Patent Classification (IPC) or to both national classification and IPC		
B. FIELDS SEARCHED		
Minimum documentation searched (classification system followed by classification symbols) D04B 21/14; A47G 9/00; A47G 9/02; A61G 7/05; B32B 5/26		
Documentation searched other than minimum documentation to the extent that such documents are included in the fields searched Korean utility models and applications for utility models Japanese utility models and applications for utility models (Chinese Patents and application for patent)		
Electronic data base consulted during the international search (name of data base and, where practicable, search terms used) eKOMPASS(KIPO internal)		
C. DOCUMENTS CONSIDERED TO BE RELEVANT		
Category*	Citation of document, with indication, where appropriate, of the relevant passages	Relevant to claim No.
X	JP 11-309183 A (MORIUCHI KYU KK) 09 November 1999 See paragraphs [0001] and [0010]-[0013]	1-17
X	US 6381779 B1 (THOMPSON; THOMAS L.) 07 May 2002 See claim 1 and figures 4-6	1
A	US 5817391 A1 (ROCK; MOSHE et al.) 06 October 1998 See column 1, line 66 - column 3, line 19	1-17
A	US 5765241 A1 (MACDONALD; ROBERT) 16 June 1998 See the whole document	1-17
<input type="checkbox"/> Further documents are listed in the continuation of Box C. <input checked="" type="checkbox"/> See patent family annex.		
* Special categories of cited documents: "A" document defining the general state of the art which is not considered to be of particular relevance "E" earlier application or patent but published on or after the international filing date "L" document which may throw doubts on priority claim(s) or which is cited to establish the publication date of citation or other special reason (as specified) "O" document referring to an oral disclosure, use, exhibition or other means "P" document published prior to the international filing date but later than the priority date claimed "T" later document published after the international filing date or priority date and not in conflict with the application but cited to understand the principle or theory underlying the invention "X" document of particular relevance; the claimed invention cannot be considered novel or cannot be considered to involve an inventive step when the document is taken alone "Y" document of particular relevance; the claimed invention cannot be considered to involve an inventive step when the document is combined with one or more other such documents, such combination being obvious to a person skilled in the art "&" document member of the same patent family		
Date of the actual completion of the international search 28 APRIL 2010 (28.04.2010)		Date of mailing of the international search report 29 APRIL 2010 (29.04.2010)
Name and mailing address of the ISA/KR  Korean Intellectual Property Office Government Complex-Daejeon, 139 Seonsa-ro, Seo-gu, Daejeon 302-701, Republic of Korea Facsimile No. 82-42-472-7140		Authorized officer KIM, Jong Kyoo Telephone No. 82-42-481-5593 

INTERNATIONAL SEARCH REPORT

Information on patent family members

International application No.

PCT/US2009/058716

Patent document cited in search report	Publication date	Patent family member(s)	Publication date
JP 11-309183 A	09.11.1999	None	
US 6381779 B1	07.05.2002	US 6678906 B1 WO 0309-2452A1	20.01.2004 13.11.2003
US 5817391 A1	06.10.1998	None	
US 5765241 A1	16.06.1998	AU 1997-12445 B2 EP 0787451 A2 EP 0787451 A3 EP 0787451 B1 GB 2309638 A	27.05.1999 06.08.1997 13.10.1999 04.06.2003 06.08.1997

PATENT COOPERATION TREATY

From the
INTERNATIONAL SEARCHING AUTHORITY

To:
SCHNEIDER RYAN A.

TROUTMAN SANDERS LLP BANK OF AMERICA
PLAZA 600 PEACHTREE STREET, N.E., SUITE 5200
ATLANTA GA 30308-2216 USA

PCT

WRITTEN OPINION OF THE
INTERNATIONAL SEARCHING AUTHORITY

(PCT Rule 43bis.1)

Date of mailing
(day/month/year) **29 APRIL 2010 (29.04.2010)**

Applicant's or agent's file reference
SHEEXIPCT

FOR FURTHER ACTION
See paragraph 2 below

International application No. PCT/US2009/058716	International filing date (day/month/year) 29 SEPTEMBER 2009 (29.09.2009)	Priority date(day/month/year) 29 SEPTEMBER 2008 (29.09.2008)
---	---	---

International Patent Classification (IPC) or both national classification and IPC

D04B 21/14(2006.01)i, D03D 11/00(2006.01)i

Applicant

SHEEX LLC et al

1. This opinion contains indications relating to the following items:

- Box No. I Basis of the opinion
- Box No. II Priority
- Box No. III Non-establishment of opinion with regard to novelty, inventive step and industrial applicability
- Box No. IV Lack of unity of invention
- Box No. V Reasoned statement under Rule 43bis.1(a)(i) with regard to novelty, inventive step or industrial applicability; citations and explanations supporting such statement
- Box No. VI Certain documents cited
- Box No. VII Certain defects in the international application
- Box No. VIII Certain observations on the international application

2. **FURTHER ACTION**

If a demand for international preliminary examination is made, this opinion will be considered to be a written opinion of the International Preliminary Examining Authority ("IPEA") except that this does not apply where the applicant chooses an Authority other than this one to be the IPEA and the chosen IPEA has notified the International Bureau under Rule 66.1bis(b) that written opinions of this International Searching Authority will not be so considered.

If this opinion is, as provided above, considered to be a written opinion of the IPEA, the applicant is invited to submit to the IPEA a written reply together, where appropriate, with amendments, before the expiration of 3 months from the date of mailing of Form PCT/ISA/220 or before the expiration of 22 months from the priority date, whichever expires later.
For further options, see Form PCT/ISA/220.

3. For further details, see notes to Form PCT/ISA/220.

Name and mailing address of the ISA/KR
Korean Intellectual Property Office
Government Complex-Daejeon, 139
Seonsa-ro, Seo-gu, Daejeon 302
-701, Republic of Korea
Facsimile No. 82-42-472-7140



Date of completion of this opinion
28 APRIL 2010 (28.04.2010)

Authorized officer
KIM, Jong Kyoo

Telephone No.82-42-481-5593



WRITTEN OPINION OF THE
INTERNATIONAL SEARCHING AUTHORITY

International application No.
PCT/US2009/058716

Box No. 1 Basis of this opinion

1. With regard to the **language**, this opinion has been established on the basis of:
 - the international application in the language in which it was filed
 - a translation of the international application into _____, which is the language of a translation furnished for the purposes of international search (Rules 12.3(a) and 23.1(b))
2. This opinion has been established taking into account the **rectification of an obvious mistake** authorized by or notified to this Authority under Rule 91 (Rule 43*bis*.1(a))
3. With regard to any **nucleotide and/or amino acid sequence** disclosed in the international application, this opinion has been established on the basis of:
 - a. a sequence listing filed or furnished
 - on paper
 - in electronic form
 - b. time of filing or furnishing
 - contained in the international application as filed.
 - filed together with the international application in electronic form.
 - furnished subsequently to this Authority for the purposes of search.
4. In addition, in the case that more than one version or copy of a sequence listing has been filed or furnished, the required statements that the information in the subsequent or additional copies is identical to that in the application as filed or does not go beyond the application as filed, as appropriate, were furnished.
5. Additional comments:

**WRITTEN OPINION OF THE
INTERNATIONAL SEARCHING AUTHORITY**

International application No.

PCT/US2009/058716

**Box No. V Reasoned statement under Rule 43bis.1(a)(i) with regard to novelty, inventive step or industrial applicability;
citations and explanations supporting such statement**

1. Statement

Novelty (N)	Claims	1-17	YES
	Claims	NONE	NO
Inventive step (IS)	Claims	NONE	YES
	Claims	1-17	NO
Industrial applicability (IA)	Claims	1-17	YES
	Claims	NONE	NO

2. Citations and explanations :

Reference is made to the following document:

D1: JP 11-309183 A (MORIUCHI KYU KK) 09 November 1999

1. Novelty and Inventive Step

1-1. Regarding claims 1-4

Most of the features of claim 1 are disclosed in D1 except for making the finished fabric at least 90 inches wide. However, it is considered to be a minor difference over the disclosure of D1, that are merely matters of design option when the general knowledge in relevant field of the art is used. Hence, no inventive step under PCT Article 33(3) is present in the subject matter of claim 1.

The additional feature of claim 2 is already disclosed in D1(see claim 3). The features added by claims 3 & 4 are considered to be a minor difference over the disclosure of D1(see paragraphs [0010]-[0013]), which fall under the general knowledge of a person skilled in the art. Hence, no inventive step under PCT Article 33(3) is present in the subject matter of claims 2-4.

1-2. Regarding claims 5-8

Most of the features of claim 5 are disclosed in D1 except for making the finished fabric at least 90 inches wide, circular knitting the fabric and stitching the fabric portions together. However, making the finished fabric at least 90 inches wide is considered to be a minor difference over the disclosure of D1, that is merely matters of design option when the general knowledge in relevant field of the art is used. Circular knitting and stitching are considered to be a minor difference over the disclosure of D1(see paragraphs [0010]-[0013]), which fall under the general knowledge of a person skilled in the art. Hence, no inventive step under PCT Article 33(3) is present in the subject matter of claim 5.

The additional feature of claim 6 is already disclosed in D1(see paragraph [0001]). The features added by claims 7 & 8 are a simple addition of conventional technique in this field as occasion demands. Hence, no inventive step under PCT Article 33(3) is present in the subject matter of claims 6-8.

1-3. Regarding claims 9-12

Most of the features of claim 9 are disclosed in D1 except for making the bed sheet at least 90 inches wide, circular knitting the fabric, stitching the fabric portions together and heat setting finishing. However, making the bed sheet at least 90 inches wide is considered to be a minor difference over the disclosure of D1, that is merely matters of design option when the general knowledge in relevant field of the art is used. Circular knitting and stitching are considered to be a minor difference over the disclosure of D1(see paragraphs [0010]-[0013]), which fall under the general knowledge of a person skilled in the art. Heat setting finishing without limitation of kinds of the material of the fiber is a simple addition of conventional technique as occasion demands. Hence, no inventive step under PCT Article 33(3) is present in the subject matter of claim 9.

Continued on Supplemental Box

WRITTEN OPINION OF THE
INTERNATIONAL SEARCHING AUTHORITY

International application No.

PCT/US2009/058716

Supplemental Box

In case the space in any of the preceding boxes is not sufficient.

Continuation of:

Box V

The feature added by claim 10 is a simple addition of conventional technique in this field as occasion demands. The additional features of claims 11 & 12 are already disclosed in D1(see paragraph [0010]-[0013]). Hence, no inventive step under PCT Article 33(3) is present in the subject matter of claims 10-12.

1-4. Regarding claims 13-17

Most of the features of claim 13 are disclosed in D1 except for the finished fabric at least 90 inches wide and the circular knitted fabric. However, the finished fabric at least 90 inches wide is considered to be a minor difference over the disclosure of D1, that is merely matters of design option when the general knowledge in relevant field of the art is used. Circular knitted fabric is considered to be a minor difference over the disclosure of D1(see paragraphs [0010]-[0013]), which fall under the general knowledge of a person skilled in the art. Hence, no inventive step under PCT Article 33(3) is present in the subject matter of claim 13.

The feature added by claim 15 is a simple addition of conventional technique in this field as occasion demands. The additional features of claims 14, 16 & 17 are already disclosed in D1(see paragraph [0010]-[0013]). Hence, no inventive step under PCT Article 33(3) is present in the subject matter of claims 14-17.

2. Industrial Applicability

The subject matter of claims 1-17 is industrially applicable meeting the requirements of Article 33(4) PCT.

IN THE UNITED STATES PATENT AND TRADEMARK OFFICE

Applicant	: Susan Walvius et al.	Art Unit	: Unknown
Serial No.	: Unknown	Examiner	: Unknown
Filed	: Unknown	Conf. No.	: Unknown
Title	: FABRIC SYSTEM		

Commissioner for Patents
P.O. Box 1450
Alexandria, VA 22313-1450

PRELIMINARY AMENDMENT

Prior to examination, please amend the application as indicated on the following pages.

Applicant : Susan Walvius et al.
Serial No. : Unknown
Filed : Unknown
Page : 2 of 6

Attorney's Docket No.: 29712-0002003

Amendments to the Specification:

Please replace the paragraph beginning at page 1, line 4 with the following amended paragraph:

This application is a continuation application of and claims priority to U.S. Serial No. 12/569,659, filed on September 29, 2009, which claims benefit under 35 USC § 119(c) of U.S. Provisional Patent Application Serial No. 61/101,049 filed 29 September 2008, which applications [[is]] are hereby incorporated fully by reference.

List of Claims (replaces all prior versions):

- 1-13. (Cancelled)
14. (New) A bed sheet comprising a fabric of a man-made fiber, the fabric having higher breathability, higher heat transfer, and higher moisture wicking characteristics than a cotton fabric.
15. (New) The bed sheet of claim 14 wherein the fabric comprises a finished fabric comprising:
- a first circular knitted fabric portion; and
 - a second circular knitted fabric portion;
 - at least one of the fabric portions comprising a performance fabric portion;
 - the first and second fabric portions being discrete and joined to form the finished fabric.
16. (New)The bed sheet of claim 14, comprising piping.
17. (New)The bed sheet of claim 15, wherein the first and second fabric portions have different fabric characteristics.
18. (New)The bed sheet of claim 17, wherein at least one of the fabric characteristics comprises moisture management.
19. (New) The bed sheet of claim 14 in which the fabric is knit of the man-made fiber.
20. (New) The bed sheet of claim 14 in which the fabric has a gauge of at least 17 gauges.
21. (New) The bed sheet of claim 14 in which the fabric is circularly knit.
22. (New) The bed sheet of claim 14 being stretchable to fit either a baby crib and an adult bed.
23. (New) The bed sheet of claim 14 that is sufficiently stretchable to fit a standard rectangular bed and a smaller, non-rectangular marine bed.
24. (New) The bed sheet of claim 14 that is sufficiently stretchable to fit either a crib or a standard adult bed.
25. (New) The bed sheet of claim 14 that is at least 90 inches wide.

26. (New) The bed sheet of claim 14 having dimensions of approximately 102 inches in length and approximately 91 inches in width.

27. (New) The bed sheet of claim 14 comprising a pull tie that can be cinched to increase tension around an edge of the bed sheet.

28. (New) The bed sheet of claim 17, wherein at least one of the fabric characteristics is UV protection.

29. (New) The bed sheet of claim 17, wherein at least one of the fabric characteristics is anti-microbial fabric.

30. (New) The bed sheet of claim 17, wherein at least one of the fabric characteristics is thermo-regulation.

31. (New) The bed sheet of claim 17, wherein at least one of the fabric characteristics is wind resistance.

32. (New) The bed sheet of claim 17, wherein at least one of the fabric characteristics is water resistance.

33. (New) A bed sheet comprising a circularly knit fabric including a high performance man-made fiber.

34. (New) The bed sheet of claim 33 that is at least 90 inches wide.

35. (New) The bed sheet of claim 33 in which the bed sheet comprises at least two portions of the circularly knit fabric.

36. (New) The bed sheet of claim 33 in which the fabric comprises polyurethanepolyurea copolymer fiber.

37. (New) The bed sheet of claim 36 in which the polyurethanepolyurea copolymer fiber is included in the fabric in a proportion such that, if circularly knit at a high gauge, the fabric could be knit at no more than a 72.5 inch circumference without losing integrity of the polyurethanepolyurea copolymer fiber.

38. (New) A bed covered by a bed sheet comprising a fabric of a man-made fiber, the fabric having higher breathability, higher heat transfer, and higher moisture wicking characteristics than a cotton fabric.

39. (New) The bed of claim 38 in which the fabric comprises comprising a circularly knit fabric.

40. (New) The bed of claim 38 wherein the bed sheet is at least 90 inches wide.

41. (New) A bed sheet comprising a fabric circularly knit of a man-made fiber, the fabric having a gauge of at least 17 gauges, and the fabric having higher breathability, higher heat transfer, and higher moisture wicking characteristics than a cotton fabric.

Applicant : Susan Walvius et al.
Serial No. : Unknown
Filed : Unknown
Page : 6 of 6

Attorney's Docket No.: 29712-0002003

REMARKS

Applicant asks that all claims be examined in view of the amendment to the claims.

Please apply any necessary charges or credits to Deposit Account 06-1050, referencing the above attorney docket number.

Respectfully submitted,

Date: October 13, 2011_____

/Frank L. Gerratana/_____
Frank L. Gerratana
Reg. No. 62,653

Customer Number 26161
Fish & Richardson P.C.
Telephone: (617) 542-5070
Facsimile: (877) 769-7945

22720717.doc

Electronic Patent Application Fee Transmittal

Application Number:				
Filing Date:				
Title of Invention:	Fabric System			
First Named Inventor/Applicant Name:	Susan Walvius			
Filer:	Frank L. Gerratana/Jennifer Franco			
Attorney Docket Number:	29712-0002003			
Filed as Large Entity				
Track I Prioritized Examination - Nonprovisional Application under 35 USC 111(a) Filing Fees				
Description	Fee Code	Quantity	Amount	Sub-Total in USD(\$)
Basic Filing:				
Utility application filing	1011	1	380	380
Utility Search Fee	1111	1	620	620
Utility Examination Fee	1311	1	250	250
Request for Prioritized Examination	1817	1	4800	4800
Pages:				
Claims:				
Claims in excess of 20	1202	8	60	480
Independent claims in excess of 3	1201	1	250	250

Description	Fee Code	Quantity	Amount	Sub-Total in USD(\$)
Miscellaneous-Filing:				
Publ. Fee- early, voluntary, or normal	1504	1	300	300
Processing Fee, except for Provis. apps	1808	1	130	130
Petition:				
Patent-Appeals-and-Interference:				
Post-Allowance-and-Post-Issuance:				
Extension-of-Time:				
Miscellaneous:				
Total in USD (\$)				7210

Electronic Acknowledgement Receipt

EFS ID:	11179983
Application Number:	13272977
International Application Number:	
Confirmation Number:	4915
Title of Invention:	Fabric System
First Named Inventor/Applicant Name:	Susan Walvius
Customer Number:	26161
Filer:	Frank L. Gerratana/Brenda Jurgens
Filer Authorized By:	Frank L. Gerratana
Attorney Docket Number:	29712-0002003
Receipt Date:	13-OCT-2011
Filing Date:	
Time Stamp:	17:39:50
Application Type:	Utility under 35 USC 111(a)

Payment information:

Submitted with Payment	yes
Payment Type	Deposit Account
Payment was successfully received in RAM	\$7210
RAM confirmation Number	4114
Deposit Account	061050
Authorized User	

File Listing:

Document Number	Document Description	File Name	File Size(Bytes)/ Message Digest	Multi Part /.zip	Pages (if appl.)
		001035			

1	TrackOne Request	Request.pdf	96183 2f207cc3e643dea9ed6686b21ab5078e2bbdf214	no	1
Warnings:					
Information:					
2	Transmittal of New Application	PAP.pdf	82033 8194f0561efc27da3f0c0baea6599fccd1601373	no	2
Warnings:					
Information:					
3		Application.pdf	1629107 b5b3d5d6cc617a94b7e26c9aad07f9c518bb4c5	yes	15
	Multipart Description/PDF files in .zip description				
	Document Description		Start	End	
	Specification		1	12	
	Claims		13	14	
	Abstract		15	15	
Warnings:					
Information:					
4	Drawings-only black and white line drawings	Drawings.pdf	1498827 343290227ffb40c4b6546bf9551a013de66c3b0f	no	4
Warnings:					
Information:					
5	Oath or Declaration filed	declaration.pdf	76105 72498dc720ef03c9acde8d8db67e7a7efefbb6fa	no	2
Warnings:					
Information:					
6		IDS.pdf	118497 83d9f3736f6aa1d7ca059e21024ee8c89dbd1c95	yes	2
	Multipart Description/PDF files in .zip description				
	Document Description		Start	End	
	Information Disclosure Statement (IDS) Form (SB08)		1	1	
	Information Disclosure Statement (IDS) Form (SB08)		2	2	
Warnings:					

Information:					
7	Foreign Reference	EP2344691.pdf	1693323 340cc85b87a3fe31dd5b481aef54ed75d045131d	no	23
Warnings:					
Information:					
8	Foreign Reference	JP11309183A.pdf	27994 a4b28f8ee98615f61a9282cf605f71716e61562	no	1
Warnings:					
Information:					
9	Foreign Reference	WO2010037082.pdf	1680495 6640506a9902cd6a0dc77cd06bd5baae388128fb	no	23
Warnings:					
Information:					
10	Non Patent Literature	AU_Voluntary_Amendment.pdf	205598 f68311c4e28fba3742b22cab8637eb21a164828	no	11
Warnings:					
Information:					
11	Non Patent Literature	IPRP.pdf	243759 27dca7d940375a8136cc2c319d6f18cde787418b	no	6
Warnings:					
Information:					
12	Non Patent Literature	ISR.pdf	328896 e38c05779fce9209ac3a3c419a6622aacbce807f	no	7
Warnings:					
Information:					
13		Prelim_Amdt.pdf	58386 61a84069a2c5ad97fced15e4ab9b02f17b0c7c5	yes	6
	Multipart Description/PDF files in .zip description				
	Document Description		Start	End	
	Preliminary Amendment		1	1	
	Specification		2	2	
	Claims		3	5	
	Applicant Arguments/Remarks Made in an Amendment 001037		6	6	

Warnings:					
Information:					
14	Fee Worksheet (SB06)	fee-info.pdf	42574	no	2
			feaf88a07c39093ed15e8f6be383d8c8705eb54		
Warnings:					
Information:					
Total Files Size (in bytes):				7781777	
<p>This Acknowledgement Receipt evidences receipt on the noted date by the USPTO of the indicated documents, characterized by the applicant, and including page counts, where applicable. It serves as evidence of receipt similar to a Post Card, as described in MPEP 503.</p> <p><u>New Applications Under 35 U.S.C. 111</u> If a new application is being filed and the application includes the necessary components for a filing date (see 37 CFR 1.53(b)-(d) and MPEP 506), a Filing Receipt (37 CFR 1.54) will be issued in due course and the date shown on this Acknowledgement Receipt will establish the filing date of the application.</p> <p><u>National Stage of an International Application under 35 U.S.C. 371</u> If a timely submission to enter the national stage of an international application is compliant with the conditions of 35 U.S.C. 371 and other applicable requirements a Form PCT/DO/EO/903 indicating acceptance of the application as a national stage submission under 35 U.S.C. 371 will be issued in addition to the Filing Receipt, in due course.</p> <p><u>New International Application Filed with the USPTO as a Receiving Office</u> If a new international application is being filed and the international application includes the necessary components for an international filing date (see PCT Article 11 and MPEP 1810), a Notification of the International Application Number and of the International Filing Date (Form PCT/RO/105) will be issued in due course, subject to prescriptions concerning national security, and the date shown on this Acknowledgement Receipt will establish the international filing date of the application.</p>					

IN THE UNITED STATES PATENT AND TRADEMARK OFFICE

Applicant : Susan Walvius et al. Art Unit : Unknown
Serial No. : Unknown Examiner : Unknown
Filed : Unknown Conf. No. : Unknown
Title : FABRIC SYSTEM

Commissioner for Patents
P.O. Box 1450
Alexandria, VA 22313-1450

INFORMATION DISCLOSURE STATEMENT

Please consider the references listed on the enclosed PTO-1449 form. Foreign patent documents and non-patent literature are enclosed; cited U.S. patents and patent application publications will be provided on request.

This statement is being filed with the application. Please apply any necessary charges or credits to Deposit Account 06-1050, referencing the above attorney docket number.

Respectfully submitted,

Date: October 13, 2011 _____

/Frank L. Gerratana/ _____
Frank L. Gerratana
Reg. No. 62,653

Customer Number 26161
Fish & Richardson P.C.
Telephone: (617) 542-5070
Facsimile: (877) 769-7945

22720718.doc

Under the Paperwork Reduction Act of 1995, no persons are required to respond to a collection of information unless it displays a valid OMB control number.

PATENT APPLICATION FEE DETERMINATION RECORD Substitute for Form PTO-875	Application or Docket Number 13/272,977	Filing Date 10/13/2011	<input type="checkbox"/> To be Mailed
---	---	----------------------------------	---------------------------------------

APPLICATION AS FILED – PART I			OTHER THAN SMALL ENTITY				
FOR	NUMBER FILED (Column 1)	NUMBER EXTRA (Column 2)	RATE (\$)	FEE (\$)		RATE (\$)	FEE (\$)
<input type="checkbox"/> BASIC FEE <small>(37 CFR 1.16(a), (b), or (c))</small>	N/A	N/A	N/A			N/A	
<input type="checkbox"/> SEARCH FEE <small>(37 CFR 1.16(k), (l), or (m))</small>	N/A	N/A	N/A			N/A	
<input type="checkbox"/> EXAMINATION FEE <small>(37 CFR 1.16(o), (p), or (q))</small>	N/A	N/A	N/A			N/A	
TOTAL CLAIMS <small>(37 CFR 1.16(j))</small>	minus 20 =	*	X \$ =		OR	X \$ =	
INDEPENDENT CLAIMS <small>(37 CFR 1.16(h))</small>	minus 3 =	*	X \$ =			X \$ =	
<input type="checkbox"/> APPLICATION SIZE FEE <small>(37 CFR 1.16(s))</small>	If the specification and drawings exceed 100 sheets of paper, the application size fee due is \$250 (\$125 for small entity) for each additional 50 sheets or fraction thereof. See 35 U.S.C. 41(a)(1)(G) and 37 CFR 1.16(s).						
<input type="checkbox"/> MULTIPLE DEPENDENT CLAIM PRESENT <small>(37 CFR 1.16(j))</small>							
* If the difference in column 1 is less than zero, enter "0" in column 2.			TOTAL			TOTAL	

APPLICATION AS AMENDED – PART II					OTHER THAN SMALL ENTITY				
	(Column 1)	(Column 2)	(Column 3)		SMALL ENTITY		OR	OTHER THAN SMALL ENTITY	
AMENDMENT	10/13/2011	CLAIMS REMAINING AFTER AMENDMENT	HIGHEST NUMBER PREVIOUSLY PAID FOR	PRESENT EXTRA	RATE (\$)	ADDITIONAL FEE (\$)		RATE (\$)	ADDITIONAL FEE (\$)
	Total <small>(37 CFR 1.16(i))</small>	* 28	Minus	** 28	=	0	OR	X \$60=	0
	Independent <small>(37 CFR 1.16(h))</small>	* 4	Minus	***4	=	0	OR	X \$250=	0
	<input type="checkbox"/> Application Size Fee <small>(37 CFR 1.16(s))</small>								
<input type="checkbox"/> FIRST PRESENTATION OF MULTIPLE DEPENDENT CLAIM <small>(37 CFR 1.16(j))</small>							OR		
					TOTAL ADD'L FEE		OR	TOTAL ADD'L FEE	0

	(Column 1)	(Column 2)	(Column 3)		SMALL ENTITY		OR	OTHER THAN SMALL ENTITY	
AMENDMENT		CLAIMS REMAINING AFTER AMENDMENT	HIGHEST NUMBER PREVIOUSLY PAID FOR	PRESENT EXTRA	RATE (\$)	ADDITIONAL FEE (\$)		RATE (\$)	ADDITIONAL FEE (\$)
	Total <small>(37 CFR 1.16(i))</small>	*	Minus	**	=		OR	X \$ =	
	Independent <small>(37 CFR 1.16(h))</small>	*	Minus	***	=		OR	X \$ =	
	<input type="checkbox"/> Application Size Fee <small>(37 CFR 1.16(s))</small>								
<input type="checkbox"/> FIRST PRESENTATION OF MULTIPLE DEPENDENT CLAIM <small>(37 CFR 1.16(j))</small>							OR		
					TOTAL ADD'L FEE		OR	TOTAL ADD'L FEE	

* If the entry in column 1 is less than the entry in column 2, write "0" in column 3.
 ** If the "Highest Number Previously Paid For" IN THIS SPACE is less than 20, enter "20".
 *** If the "Highest Number Previously Paid For" IN THIS SPACE is less than 3, enter "3".
 The "Highest Number Previously Paid For" (Total or Independent) is the highest number found in the appropriate box in column 1.

Legal Instrument Examiner:
 /LAJUAN HICKSON/

This collection of information is required by 37 CFR 1.16. The information is required to obtain or retain a benefit by the public which is to file (and by the USPTO to process) an application. Confidentiality is governed by 35 U.S.C. 122 and 37 CFR 1.14. This collection is estimated to take 12 minutes to complete, including gathering, preparing, and submitting the completed application form to the USPTO. Time will vary depending upon the individual case. Any comments on the amount of time you require to complete this form and/or suggestions for reducing this burden, should be sent to the Chief Information Officer, U.S. Patent and Trademark Office, U.S. Department of Commerce, P.O. Box 1450, Alexandria, VA 22313-1450. DO NOT SEND FEES OR COMPLETED FORMS TO THIS ADDRESS. **SEND TO: Commissioner for Patents, P.O. Box 1450, Alexandria, VA 22313-1450.**
 If you need assistance in completing the form, call 1-800-PTO-9199 and select option 2.