

UNITED STATES PATENT AND TRADEMARK OFFICE

BEFORE THE PATENT TRIAL AND APPEAL BOARD

SAMSUNG ELECTRONICS CO., LTD.,
SAMSUNG ELECTRONICS AMERICA, INC., and LG ELECTRONICS,
INC.

Petitioner,

v.

PAPST LICENSING GMBH & CO. KG,
Patent Owner.

Case IPR2016-01733¹
Patent 9,189,437 B2

Before JONI Y. CHANG, JENNIFER S. BISK, and
MIRIAM L. QUINN, *Administrative Patent Judges*.

BISK, *Administrative Patent Judge*.

FINAL WRITTEN DECISION
35 U.S.C. § 318(a) and 37 C.F.R. § 42.73

¹ LG Electronics, Inc. (“LG”) filed a petition and motion to join this case in IPR2017-01038. We granted that motion and joined the two cases on April 11, 2017. Paper 10. Subsequently, LG and Patent Owner filed a joint motion to terminate the proceeding as to LG. Paper 22.

I. INTRODUCTION

Samsung Electronics Co., Ltd., and Samsung Electronics America, Inc. (collectively “Petitioner”) filed a Petition requesting an *inter partes* review of claims 1–45 (“the challenged claims”) of U.S. Patent No. 9,189,437 B2 (Ex. 1003, “the ’437 patent”). Paper 1 (“Pet.”). Patent Owner, Papst Licensing GmbH & Co., KG (“Patent Owner”), filed a Preliminary Response. Paper 6 (“Prelim. Resp.”). We instituted this review as to all challenged claims. Paper 7 (“Inst. Dec.”).

Subsequent to institution, Patent Owner filed a Patent Owner Response. Paper 13 (“PO Resp.”). Petitioner filed a Reply. Paper 15 (“Reply”). A transcript of the oral hearing held on November 1, 2017, has been entered into the record as Paper 23 (“Tr.”).

This Final Written Decision is entered pursuant to 35 U.S.C. § 318(a). For the reasons that follow, Petitioner has demonstrated by a preponderance of the evidence that claims 1–38 and 43–45 of the ’437 patent are unpatentable, but not as to claims 39–42.

A. *Related Matters*

The parties indicate that the ’437 patent is involved in *Papst Licensing GmbH & Co. KG v. Canon Inc.*, Case No. 1:15-cv-01692 (D.D.C.) and other proceedings. Pet. 80–81; Paper 5, 2–3.

The ’437 patent has also been challenged in several other petitions for *inter partes* review. All but one of these petitions—IPR2016-01842—was denied. *See* IPR2016-01840; IPR2016-01841; IPR2016-01844; IPR2017-

00156; IPR2017-00712. IPR2016-01842 was instituted April 27, 2017 and is proceeding concurrently with this case.

B. The '437 Patent

The '437 patent describes an interface device for communication between a computer host device and a data transmit/receive device (e.g., a multi-meter, transmitting measured data to a computer). Ex. 1003, 1:18–22, 1:54–57. According to the '437 patent, using a specific driver to match very closely to an individual host system would achieve high data transfer rates across the interface, but the specific driver cannot be used with other host systems. *Id.* at 2:4–19. Several solutions to this problem were known in the art. *Id.* at 2:20–3:25. For example, IOtech introduced an interface device for laptops, using a plug-in card for converting the personal computer memory card association (PCMCIA) interface into a known standard interface (IEEE 1284). *Id.* at 2:23–29. The plug-in card provided a printer interface for enhancing data transfer rates. *Id.* at 2:29–33. In another example, a floppy disk drive interface was used for connecting a host device to a peripheral device. *Id.* at 3:10–14. The interface appeared as floppy disk drive to the host, allowing a floppy disk drive and another peripheral device to be connected to the host device. *Id.* at 3:17–19.

The '437 patent indicates that the purported “invention is based on the finding that both a high data transfer rate and host device-independent use can be achieved if a driver for an input/output device customary in a host device” is utilized. *Id.* at 3:33–37. Figure 1 of the '437 patent, reproduced below, illustrates a block diagram of an interface device.

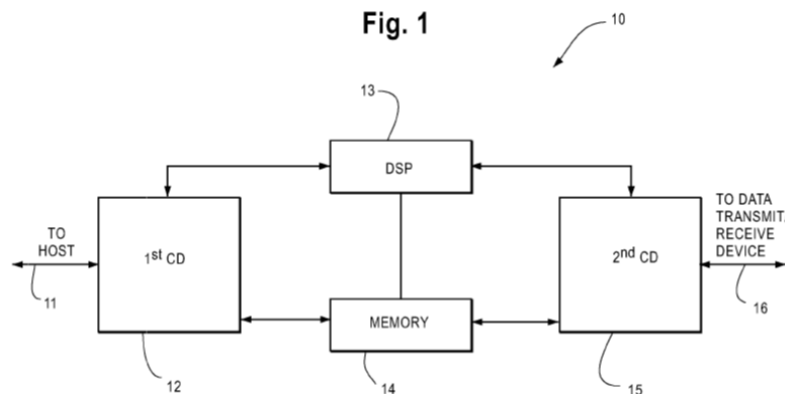

As shown in Figure 1 above, interface device 10 connects to a host device via host line 11, and to a data transmit/receive device via output line 16. *Id.* at 4:62–5:10. Interface device 10 includes first connecting device 12, second connecting device 15, digital signal processor 13, and memory means 14. *Id.* In a preferred embodiment, the interface device is attached to a host device via a multi-purpose interface—e.g., a small computer systems interface (SCSI) interface—which includes both an interface card and the driver for the interface card. *Id.* at 3:51–57, 8:42–46. According to the '437 patent, SCSI interfaces were known to be present on most host devices or laptops. *Id.* at 8:42–46. By using a standard interface of a host device and by simulating an input/output device to the host device, the interface device “is automatically supported by all known host systems without any additional sophisticated driver software.” *Id.* at 11:38–44.

C. Illustrative Claim

Of the challenged claims, claims 1, 39, 41, and 43 are independent. Claims 2–38 depend ultimately from claim 1; claim 40 depends from claim 39; claim 42 depends from claim 41; and claims 44 and 45 depend from claim 43. Claim 1 is illustrative:

1. An analog data generating and processing device (ADGPD), comprising:

an input/output (i/o) port;

a program memory;

a data storage memory;

a processor operatively interfaced with the i/o port, the program memory and the data storage memory;

wherein the processor is adapted to implement a data generation process by which analog data is acquired from each respective analog acquisition channel of a plurality of independent analog acquisition channels, the analog data from each respective channel is digitized, coupled into the processor, and is processed by the processor, and the processed and digitized analog data is stored in the data storage memory as at least one file of digitized analog data;

wherein the processor also is adapted to be involved in an automatic recognition process of a host computer in which, when the i/o port is operatively interfaced with a multi-purpose interface of the host computer, the processor executes at least one instruction set stored in the program memory and thereby causes at least one parameter identifying the analog data generating and processing device, independent of analog data source, as a digital storage device instead of an analog data generating and processing device to be automatically sent through the i/o port and to the multi-purpose interface of the computer (a) without requiring any end user to load any software onto the computer at any time and (b) without requiring any end user to interact with the computer to set up a file system in the ADGPD at any time, wherein the at least one parameter is consistent with the ADGPD being responsive to commands issued from a customary device driver;

wherein the at least one parameter provides information to the computer about file transfer characteristics of the ADGPD;

Explore Litigation Insights

Docket Alarm provides insights to develop a more informed litigation strategy and the peace of mind of knowing you're on top of things.

Real-Time Litigation Alerts



Keep your litigation team up-to-date with **real-time alerts** and advanced team management tools built for the enterprise, all while greatly reducing PACER spend.

Our comprehensive service means we can handle Federal, State, and Administrative courts across the country.

Advanced Docket Research



With over 230 million records, Docket Alarm's cloud-native docket research platform finds what other services can't. Coverage includes Federal, State, plus PTAB, TTAB, ITC and NLRB decisions, all in one place.

Identify arguments that have been successful in the past with full text, pinpoint searching. Link to case law cited within any court document via Fastcase.

Analytics At Your Fingertips



Learn what happened the last time a particular judge, opposing counsel or company faced cases similar to yours.

Advanced out-of-the-box PTAB and TTAB analytics are always at your fingertips.

API

Docket Alarm offers a powerful API (application programming interface) to developers that want to integrate case filings into their apps.

LAW FIRMS

Build custom dashboards for your attorneys and clients with live data direct from the court.

Automate many repetitive legal tasks like conflict checks, document management, and marketing.

FINANCIAL INSTITUTIONS

Litigation and bankruptcy checks for companies and debtors.

E-DISCOVERY AND LEGAL VENDORS

Sync your system to PACER to automate legal marketing.