



United States Patent [19]

[11] **Patent Number:** **5,810,873**

Morales

[45] **Date of Patent:** **Sep. 22, 1998**

[54] **STENT CRIMPING TOOL AND METHOD OF USE**

5,626,604	5/1997	Cottone, Jr.	606/198
5,630,830	5/1997	Verbeek .	
5,672,169	9/1997	Verbeek	623/1

[75] Inventor: **Stephen A. Morales**, Mountain View, Calif.

OTHER PUBLICATIONS

The eXtraordinary Stent, C.R. Bard Brochure (Undated). Application for U.S. Letters Patent No. 08/837,771 filed Apr. 22, 1997.
 Application for U.S. Letters Patent No. 08/795,335 filed Feb. 4, 1997.

[73] Assignee: **Advanced Cardiovascular Systems, Inc.**, Santa Clara, Calif.

Primary Examiner—William Lewis
Attorney, Agent, or Firm—Fulwider Patton Lee & Utecht, LLP

[21] Appl. No.: **893,936**

[22] Filed: **Jul. 15, 1997**

[51] **Int. Cl.⁶** **A61M 29/00**; A61B 17/00

[52] **U.S. Cl.** **606/198**; 606/1

[58] **Field of Search** 606/1, 108, 191, 606/192, 194, 195, 198, 200; 623/1, 12; 29/234, 235, 282, 283

[57] ABSTRACT

A device for enabling crimping of an intravascular stent onto a balloon catheter assembly. The stent crimping device includes a pair of elements, adapted to be held in the hands of the user, which enable one element, in which a stent and balloon catheter assembly are positioned to slidably move relative to the other element, and to move through a tapered opening to crimp the stent onto the balloon catheter assembly.

[56] References Cited

U.S. PATENT DOCUMENTS

4,907,336	3/1990	Gianturco .
5,132,066	7/1992	Charlesworth et al. .
5,133,732	7/1992	Wiktor .
5,183,085	2/1993	Timmermans .
5,546,646	8/1996	Williams et al. .

20 Claims, 2 Drawing Sheets

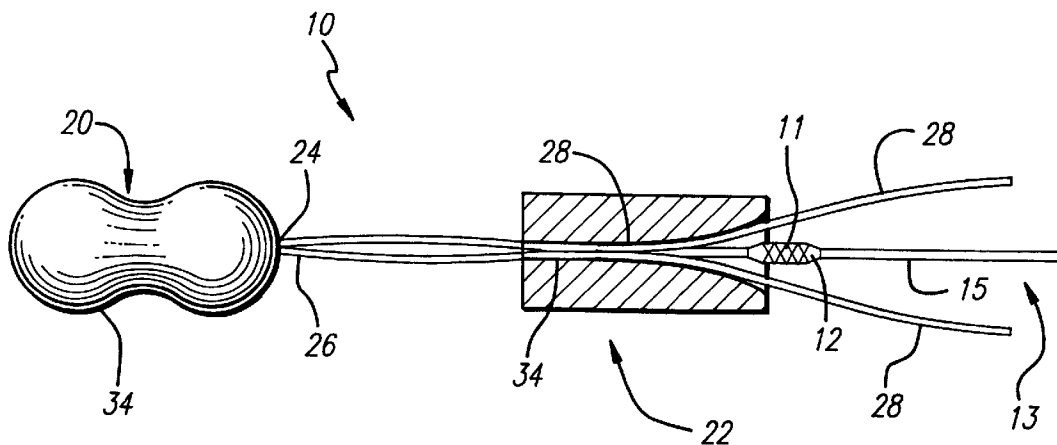

Edwards Lifesciences v. Boston Scientific
U.S. Patent No. 6,915,560
IPR2017-00072 EX. 2006

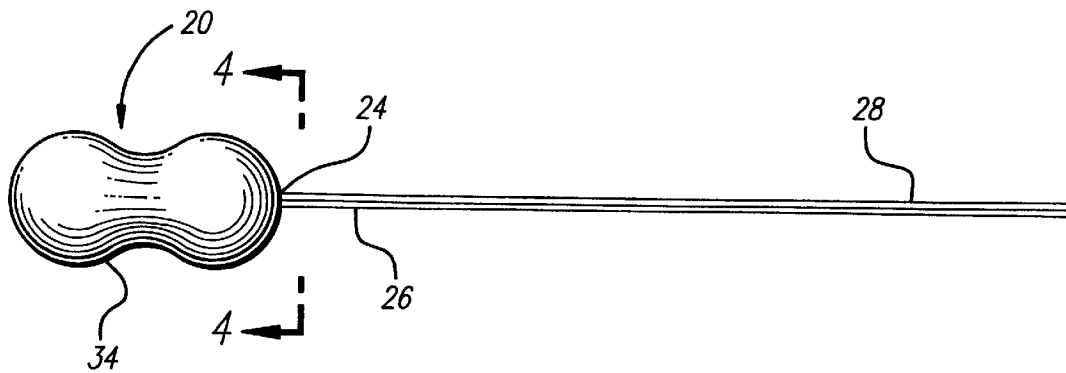
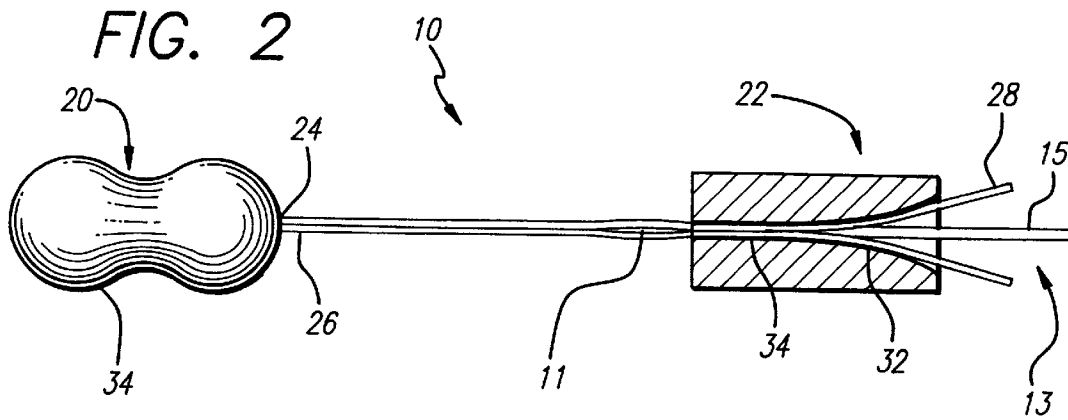
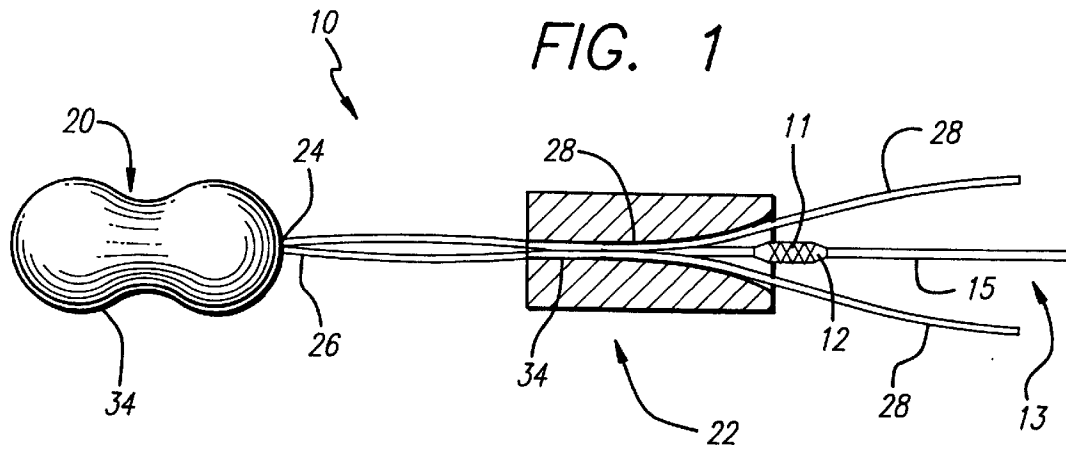

FIG. 3

FIG. 4

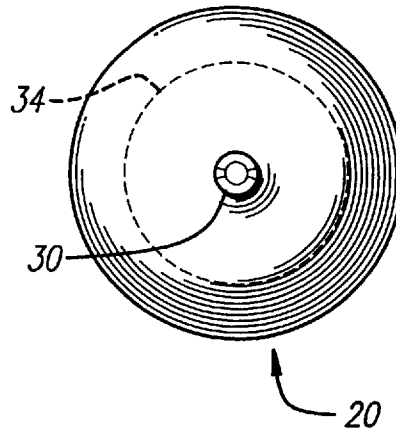

FIG. 5

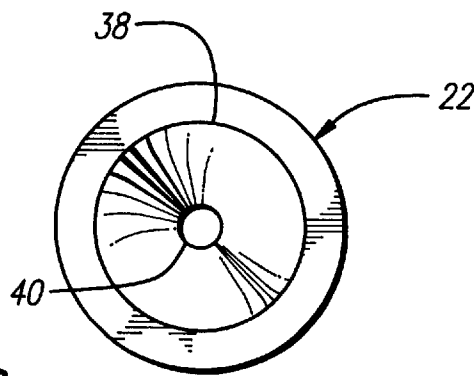
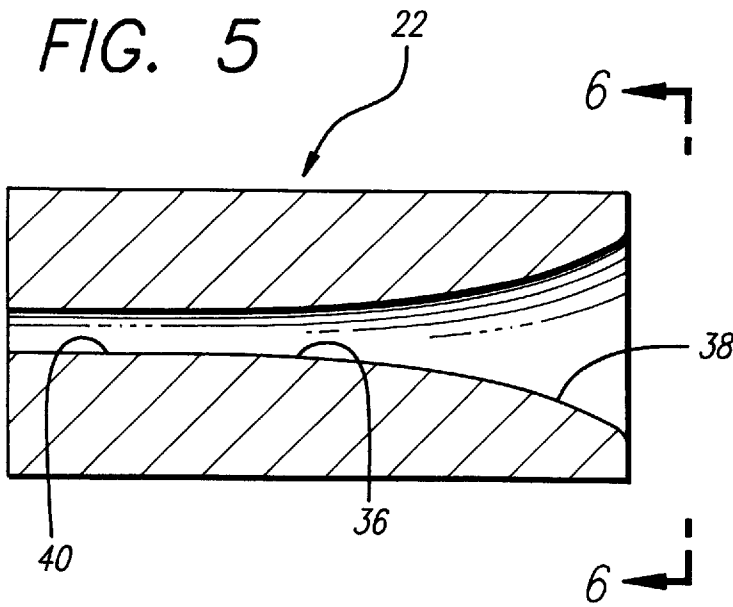

FIG. 6

STENT CRIMPING TOOL AND METHOD OF USE

BACKGROUND OF THE INVENTION

1. Field of the Invention

The invention relates to a stent crimping device of the type that will enable the user to crimp a stent onto the distal end of a balloon catheter assembly, for example, of the kind used in a typical percutaneous transluminal coronary angioplasty (PTCA) or percutaneous transluminal angioplasty (PTA) procedure.

2. Description of the Related Art

In a typical PTCA procedure, for compressing lesion plaque against the artery wall to dilate the artery lumen, a guiding catheter is percutaneously introduced into the cardiovascular system of a patient through the brachial or femoral arteries and advanced through the vasculature until the distal end is in the ostium of the aorta. A guidewire and a dilatation catheter having a balloon on the distal end are introduced through the guiding catheter with the guidewire sliding within the dilatation catheter. The guidewire is first advanced out of the guiding catheter into the patient's coronary vasculature, and the dilatation catheter is advanced over the previously advanced guidewire until the dilatation balloon is properly positioned across the lesion. Once in position across the lesion, the balloon is inflated to a predetermined size with radiopaque liquid at relatively high pressures to radially compress the atherosclerotic plaque of the lesion against the inside of the artery wall and thereby dilate the lumen of the artery. The balloon is then deflated to a small profile, so that the dilatation catheter can be withdrawn from the patient's vasculature and blood flow resumed through the dilated artery. While this procedure is typical, it is not the only method used in angioplasty.

In angioplasty procedures of the kind referenced above, restenosis of the artery may develop over several months, which may require another angioplasty procedure, a surgical bypass operation, or some method of repairing or strengthening the area. To reduce the chance of the development of restenosis and strengthen the area, an intravascular prosthesis is implanted for maintaining vascular patency, typically called a stent. A stent is a device used to hold tissue in place in a vessel or to provide a support for a vessel to hold it open so that blood flows freely. A variety of devices are known in the art for use as stents, including balloon expandable tubular members, in a variety of patterns, that are able to be crimped onto a balloon catheter, and expanded after being positioned intraluminally on the balloon catheter, and that retain their expanded form. Typically, the stent is loaded and crimped onto the balloon portion of the catheter, and advanced to a location inside the artery after a PTCA or PTA procedure. The stent is then expanded to a larger diameter, by the balloon portion of the catheter, to implant the stent in the artery. Typical stents and delivery catheters are disclosed in U.S. Pat. Nos. 5,514,154 (Lau et al.), 5,569,295 (Lam) and 5,507,768 (Lau et al.), which are incorporated herein by reference.

However, if the stent is not tightly crimped onto the catheter balloon portion, when the catheter is advanced in the patient's vasculature the stent may move or even slide off the catheter balloon portion in the coronary artery prior to expansion, and may block the flow of blood, requiring procedures to remove the stent.

In procedures where the stent is placed over the balloon portion of the catheter, the stent must be crimped onto the balloon portion to prevent the stent from sliding off the

catheter when the catheter is advanced in the patient's vasculature. In the past this crimping was often done by hand, which does not provide optimum results due to the uneven force being applied, resulting in non-uniform crimps. In addition, it was difficult to judge when a uniform and reliable crimp had been applied. Though some tools, similar to ordinary pliers, have been used to apply the stent, these tools have not been entirely adequate in achieving a uniform crimp. Moreover, an unevenly crimped stent may result in an unevenly expanded stent in the vessel or artery, which is undesirable.

The present invention solves the problems associated with the prior art devices and provides a crimping tool that tightly and uniformly crimps the stent on the balloon portion of the catheter.

SUMMARY OF THE INVENTION

The invention is directed to a stent crimping device which enables crimping of a stent onto a catheter balloon portion, to better secure the stent onto the catheter for delivery of the stent through the patient's vasculature.

In an exemplary embodiment of the present invention, the stent crimping device includes a pair of elements adapted to be held in the hands of the user, to enable the user to move one element relative to the other, and to slide the stent and balloon catheter assembly, connected to one element, through a restricted opening in the other element, through which the stent and balloon catheter assembly are slidably movable. The restricted opening applies compressive force on the stent and balloon catheter assembly, to crimp the stent onto the balloon catheter assembly.

The device enables the stent to be tightly and uniformly crimped onto the distal end of a balloon catheter, reducing the risk that the stent may slide off the catheter balloon portion.

These and other advantages of the invention will become more apparent from the following detailed description thereof when taken in conjunction with the accompanying drawings.

BRIEF DESCRIPTION OF THE DRAWINGS

FIG. 1 is a partial sectional elevational view of an exemplary embodiment of the present invention, prior to slidably moving the stent and catheter balloon assembly through a restricted opening in an element.

FIG. 2 is a view similar to FIG. 1 after the stent and catheter balloon portion have slidably moved through the restricted opening such that the stent is crimped onto the catheter balloon portion.

FIG. 3 is a side partial fragmentary elevational view of the element from which strands and the balloon catheter extend.

FIG. 4 is an end elevational view of the element shown in FIG. 3, taken along line 4—4 of FIG. 3.

FIG. 5 is a side elevational sectional view of the element through which the stent and catheter balloon portion are slidably movable.

FIG. 6 is an end elevational view of the element shown in FIG. 5, taken along line 6—6 of FIG. 5.

DETAILED DESCRIPTION OF THE PREFERRED EMBODIMENTS

The stent crimping device of the present invention is designed to allow a catheter lab (cath lab) physician or personnel to crimp a stent onto the balloon portion of a

catheter. The stent crimping device will allow cath lab personnel to crimp essentially any type of balloon-expandable stent onto any type of balloon catheter, such as a typical balloon dilatation catheter used in a PTCA or PTA procedure.

The stent crimping device is formed generally of two parts including a handle portion and a cylinder portion which are designed to be held in the user's hands for drawing the stent and balloon through the tapered cylinder portion to crimp the stent onto the balloon. The handle and cylindrical portion are depicted as having preferred shapes, however, as will be appreciated these shapes can be modified to suit specific cath lab requirements or to accommodate stent and balloon catheter assemblies having various dimensions.

As can be seen in FIGS. 1 and 2, stent crimping tool 10 comprises handle element 20 and cylindrical element 22 for crimping an intravascular stent 11 onto the collapsed balloon portion 12 of a balloon catheter assembly 13. In the exemplary embodiment of tool 10, as shown in FIGS. 1-6, handle element 20 and cylindrical element 22 are adapted to be held in the hands of the user, so as to enable the user to slide stent 11 and balloon catheter portion 12 through the cylindrical element, to apply compressive force thereto to crimp the stent onto balloon portion of the catheter.

As shown in FIGS. 3 and 4, handle element 20 includes an opening 24 therein, in which first end 14 of catheter 15 is insertable so as to be releasably retained therein. First ends 26 of a plurality of thin elongated strands 28, comprised of flexible material, are secured in opening 24, and strands 28 extend therefrom so as to be extendable along and about catheter 15 and stent-loaded balloon catheter portion 12 thereof.

Opening 24 may have a diameter, for example, ranging from about 0.0500 to 0.2000 inch, with six sections 30 formed therein extending arcuately at 60° angles, for securing first ends 26 of elongated strands 28 therein. The elongate strands 28, having six sections 30, essentially form a cylindrical tube for receiving the stent and balloon prior to and during the crimping procedure. Depending upon the diameter of opening 24, it may be necessary to increase or decrease the number of sections 30, which may range from a single annular section up to perhaps twelve sections. Sections 30 are preferably arcuate-shaped, but can be flat or rectangular.

Handle element 20 further includes a reduced diameter gripping portion 34 for enabling the user to grip and pull elongate strands 28 through the cylindrical element.

Cylindrical element 22, as depicted in FIGS. 5 and 6, includes channel 36 extending therethrough. Catheter 15, stent-loaded balloon catheter portion 12 thereof, and strands 28 all are slidably-movable through channel 36. Channel 36 includes channel first portion 38 having a diameter greater than the diameter of stent-loaded balloon catheter portion 12 and strands 28, tapering to a reduced diameter substantially the same as the diameter of stent-loaded balloon catheter portion and strands 28. The diameter of channel first portion 38 may, for example, taper from a diameter of 0.250 inch to a diameter of 0.034 inch. Channel 36 includes channel second portion 40 having a diameter substantially the same as the diameter of stent-loaded balloon catheter portion and strands 28 after crimping stent 11 onto balloon catheter portion 12. For example, the diameter of channel second portion 40 may be a constant 0.034 inch. Since the diameter of channel second portion 40 defines the stent crimped diameter, the diameter can vary depending upon the application.

In the preferred method of crimping, the stent is loaded onto the deflated balloon portion of the catheter assembly. The elongate strands 28 are already positioned and extending through the cylindrical element and flared outwardly to receive balloon portion 12 and stent 11 of catheter assembly 13. The user then grips handle element 20 in one hand and cylindrical element 22 in the other hand and pulls the two assemblies in opposite directions so that the elongate strands 28 collapse onto the stent and balloon portion of the catheter assembly. Continued pulling of the assemblies in opposite directions results in the stent and balloon portion of the catheter assembly to be drawn through the continually narrowing taper formed in the second cylindrical element. The stent is gradually crimped onto the balloon portion of the catheter assembly as it is pulled through the taper and into and through channel second portion 40, the diameter of which substantially defines the crimped diameter of the stent with the thickness of the elongate strands around the stent. Continued pulling of the handle element in the opposite direction of the cylindrical element permits elongate strands 28 to be pulled clear of the second cylindrical element along with the now crimped stent. Thereafter, the stent and balloon portion of the catheter assembly can be carefully pulled back through the cylindrical element without the elongate strands, resulting in the stent being tightly crimped onto the balloon portion of the catheter.

The stent crimping tool 10 is designed to come either assembled or unassembled so that the cath lab personnel can choose the appropriate diameter of the channel second portion 40. The inner diameter of the channel second portion, in one preferred embodiment, may be about 0.034 inch. It will be appreciated, however, that this diameter can vary substantially depending upon the diameter of a deflated balloon, including the diameter or thickness of the stent when crimped onto the balloon, taken in conjunction with the diameter of the vessel which receives the implanted stent. Thus, for example, for a saphenous vein graft (SVG), the inner diameter of cylindrical element 22 may be much larger than 0.034 inch. As is clear, the resulting diameter of the stent as crimped onto the balloon is a matter of choice of the cath lab personnel to fit the particular application.

As can be appreciated, stent crimping tool 10 is designed for crimping stents having various diameters onto the balloon portion of a catheter. In order to more easily accommodate varying diameters of stents and to insure that the crimping process is smooth and results in a non-locking taper, the taper created by channel first portion 38 as it reduces in diameter to channel second portion 40, preferably angles in range of about 100 to 200 from the longitudinal axis of channel 36.

The stent crimping tool is designed for one-time use in a cath lab and it is intended to be destroyed after each use so that sterilization after use does not become a factor. The stent crimping device also can be used by stent and catheter manufacturers to crimp their stents onto catheters and package the assembly for sale to cath labs.

In one preferred embodiment, the handle element and the cylindrical element are formed from a rigid plastic which is capable of being machined into the specific dimensions for optimal performance. The inner diameter of cylindrical element 22 typically will be bored so that precise diameters can be achieved, since it will define the final crimped diameter of the stent. Moreover, it is important to provide a channel that is uniform and free of machining irregularities such as nicks or ridges. Thus, channel 40 preferably is bored or machined to provide precise diameters.

In order to facilitate drawing the elongate strands through the tapered bore or channel of the cylindrical element, a

Explore Litigation Insights

Docket Alarm provides insights to develop a more informed litigation strategy and the peace of mind of knowing you're on top of things.

Real-Time Litigation Alerts



Keep your litigation team up-to-date with **real-time alerts** and advanced team management tools built for the enterprise, all while greatly reducing PACER spend.

Our comprehensive service means we can handle Federal, State, and Administrative courts across the country.

Advanced Docket Research



With over 230 million records, Docket Alarm's cloud-native docket research platform finds what other services can't. Coverage includes Federal, State, plus PTAB, TTAB, ITC and NLRB decisions, all in one place.

Identify arguments that have been successful in the past with full text, pinpoint searching. Link to case law cited within any court document via Fastcase.

Analytics At Your Fingertips



Learn what happened the last time a particular judge, opposing counsel or company faced cases similar to yours.

Advanced out-of-the-box PTAB and TTAB analytics are always at your fingertips.

API

Docket Alarm offers a powerful API (application programming interface) to developers that want to integrate case filings into their apps.

LAW FIRMS

Build custom dashboards for your attorneys and clients with live data direct from the court.

Automate many repetitive legal tasks like conflict checks, document management, and marketing.

FINANCIAL INSTITUTIONS

Litigation and bankruptcy checks for companies and debtors.

E-DISCOVERY AND LEGAL VENDORS

Sync your system to PACER to automate legal marketing.