

TICONA

***SNAP-FITS FOR
ASSEMBLY AND DISASSEMBLY***

Presented by:

**Tim Spahr
Technical Service Engineer**

**November 1991
(Revised 1/00)**



GENERAL DISCUSSION

An economical and quick method of joining plastic parts is by a snap-fit joint. A snap-fit joint can be designed so it is easily separated or so that it is inseparable, without breaking one of its components. The strength of the snap-fit joint depends on the material used, its geometry and the forces acting on the joint.

Most all snap-fit joint designs share the common design features of a protruding ledge and a snap foot. Whether the snap joint is a cantilever or a cylindrical fit, they both function similarly.

When snap-fit joints are being designed, it is important to know the mechanical stresses to be applied to the snap beams after assembly, the required mechanical stresses or strains on the snap beams during assembly, the number of times the snap joint will be engaged and disengaged, and the mechanical limits of the material(s) to be used in the design.

Reasons to Use Snap-Fits:

- Reduces assembly costs.
- Are typically designed for ease of assembly and are often easily automated.
- Replaces screws, nuts, and washers.
- Are molded as an integral component of the plastic part.
- No welding or adhesives are required.
- They can be engaged and disengaged.

Things To Be Aware of When Using Snap-Fits:

- Some designs require higher tooling cost.
- They are susceptible to breakage due to mishandling and abuse prior to assembly.
- Snap-fits that are assembled under stress will creep.
- It is difficult to design snap-fits with hermetic seals. If the beam and/or ledge relaxes, it could decrease the effectiveness of the seal.

TYPES OF SNAP-FIT JOINTS

There are a wide range of snap-fit joint designs. In their basic form, the most often used are the cantilever beam (snap leg), Figure 1, and the cylindrical snap-fit joint, Figure 2. For this reason, these two designs and designs derived from these basics are covered in this text.

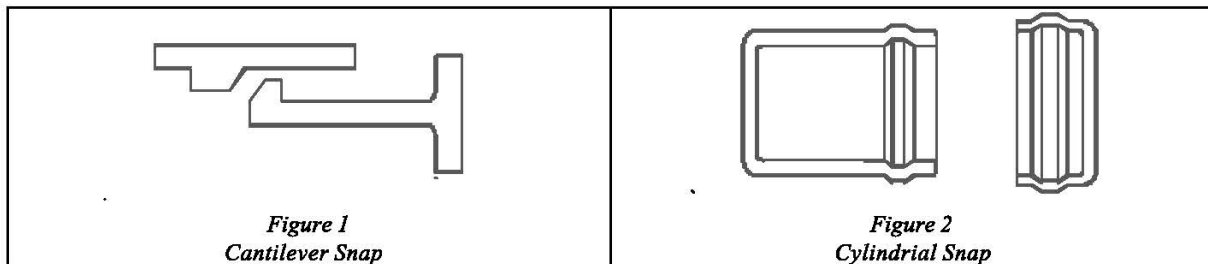

Cantilever Snap Beams

Using the standard beam equations, we can calculate the stress and strain during assembly of the snap beam. If we stay below the elastic limit of the material, we know the flexing beam will return to its original position. However, for such designs, there is usually not enough holding power with the low forces or small deflections involved.

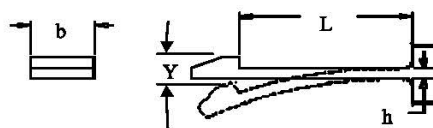

Figure 3

Therefore, much higher deformations are generally used. With most plastic materials, the bending stress calculated by using simple linear bending methods (Equations 1-3) can far exceed the recognized yield strength of the material. This is particularly true when large deflections are used and when the assembly occurs rapidly.

Therefore, it often appears as if the beam momentarily passes through the maximum deflection or strain, greatly exceeding its yield strength while showing no ill effects from the event.

What actually happens is described later.

For the present, simply note that the snap beams are usually designed to a strain rather than a stress.

$$\sigma = \frac{FL}{Z} \quad \text{Equation 1}$$

$$Y = \frac{FL^3}{3EI} \quad \text{Equation 2}$$

$$\sigma = E\varepsilon \quad \text{Equation 3}$$

Where:

σ = Maximum stress on beam

F = Force on the beam

L = Length of the beam

$Z = \frac{I}{c}$, Section Modulus

$c = \frac{d}{2}$ = Half the beam height

$I = \frac{bd^3}{12}$, Moment of inertia

h = Beam height

b = Beam width

ε = Maximum strain on beam

Y = Beam deflection

The strain should not exceed the allowable dynamic strain for the particular material being used. By combining Equations 1-3, the design equation (Equation 4) can be produced. Note that the strain is written in terms of the height, length, and deflection of the beam.

$$\varepsilon = \frac{3YH}{2L^2} \quad \text{Equation 4}$$

Strain Guidelines

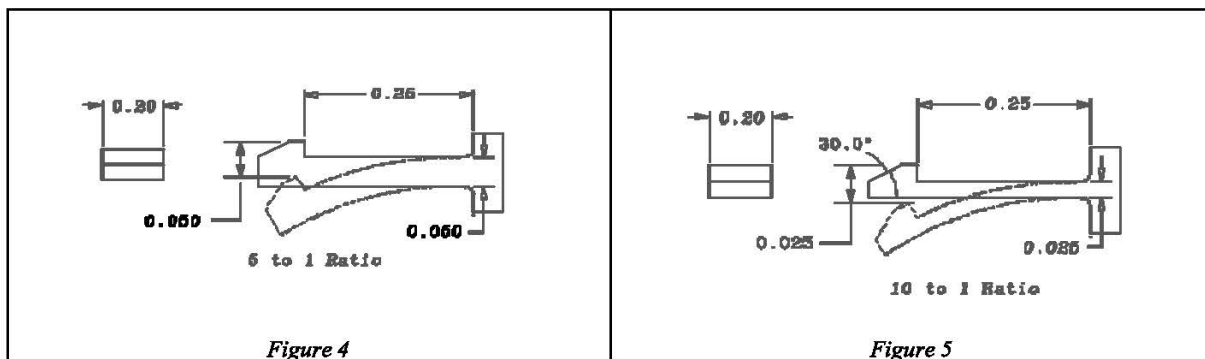

Generally speaking, an unfilled material can withstand a strain level of around 6% and a filled material of around 1.5%. As a reference, a 6% strain level could be a beam with a thickness that is equal to 20% of its length (a 5: 1 L/h_0) and a deflection that is also equal to 20% of its length (see Figure 5). A 1.5% strain level could be a beam with a thickness that is equal to 10% of its length (10: 1 L/h_0) and a deflection that is equal to 10% of its length (see Figure 4). If using a beam that is tapered so the thickness at the base of the snap foot is 50% that of the base of the beam, the length of the beam will approximately 78% (0.7819346 calculated) the length of the 6% and 1.5% beams with uniform thickness.

A more accurate guideline for the allowable dynamic strain curve of the material may be obtained from the material's stress strain curve. The allowable dynamic strain, for most thermoplastics materials with a definite yield point, may be as high as 70% of the yield point strain (see Figure 7). For other materials, that break at low elongations without yielding, a strain limit as high as 50% of the strain at break may be used (see Figure 6). If the snap joint is required to be engaged and disengaged more than once, the beam should be designed to 60% of the above recommended strain levels. However, the best source for allowable dynamic strain is the material supplier.

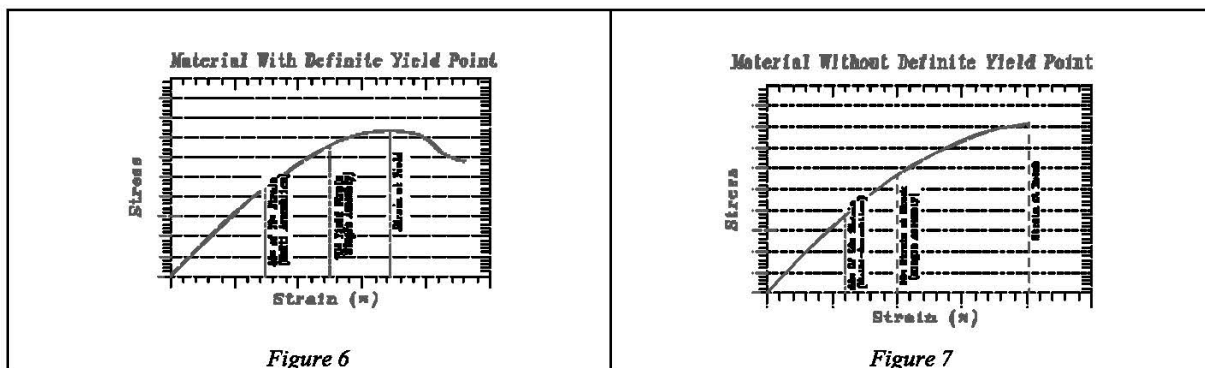

Modulus of Elasticity vs. Secant Modulus

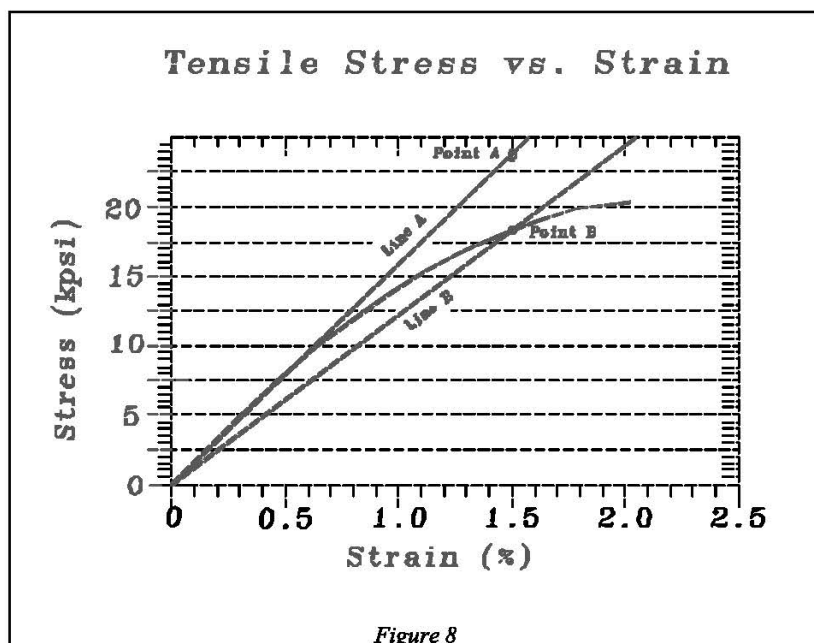

Figure 8

Before going further, we need to examine the actual stresses and forces developed in a snap finger. Figure 8 shows a stress strain curve for a brittle thermoplastic material. The straight line portion of the curve is the region where stress is proportional to strain. Line A is drawn tangent to this region

The slope of Line A is generally reported as the modulus of elasticity (Young's modulus or initial modulus) of the material. Many plastics do not possess this straight-line region. For these materials, Line A is constructed tangent at the origin to obtain the modulus of elasticity. If we designed a snap beam at 1.5% strain for this material in Figure 8 using Equations 1-4 and a modulus of elasticity of 1.6×10^6 psi (given by the material) as determined from Line A, the resulting stress would be 24,000 psi, Point A on Line A. However, from the stress strain curve it can be seen that the true stress at 1.5% strain is about 18,000 psi, Point B on the curve. In addition, the deflection force predicted by Equations 1-4 will be high by the same proportions.

Now, to make our math easier, we need some method to force Equations 1-4 to give us the proper stress and force results. If we construct a secant line from the origin to Point B, Line B, the slope of Line B is the material modulus just as the slope of Line A is the modulus of elasticity. The slope of Line B is the secant modulus for the material at Point B and is approximately 18,000 psi divided by 1.5% strain or 1.2×10^6 psi. Obviously, the secant modulus can be calculated for any point on the stress-strain curve. Plots of the secant modulus vs. strain (or stress) can then be produced, if desired. Obviously, at the lower strains, the Secant Modulus should approach the modulus of elasticity of the material.

Explore Litigation Insights

Docket Alarm provides insights to develop a more informed litigation strategy and the peace of mind of knowing you're on top of things.

Real-Time Litigation Alerts



Keep your litigation team up-to-date with **real-time alerts** and advanced team management tools built for the enterprise, all while greatly reducing PACER spend.

Our comprehensive service means we can handle Federal, State, and Administrative courts across the country.

Advanced Docket Research



With over 230 million records, Docket Alarm's cloud-native docket research platform finds what other services can't. Coverage includes Federal, State, plus PTAB, TTAB, ITC and NLRB decisions, all in one place.

Identify arguments that have been successful in the past with full text, pinpoint searching. Link to case law cited within any court document via Fastcase.

Analytics At Your Fingertips



Learn what happened the last time a particular judge, opposing counsel or company faced cases similar to yours.

Advanced out-of-the-box PTAB and TTAB analytics are always at your fingertips.

API

Docket Alarm offers a powerful API (application programming interface) to developers that want to integrate case filings into their apps.

LAW FIRMS

Build custom dashboards for your attorneys and clients with live data direct from the court.

Automate many repetitive legal tasks like conflict checks, document management, and marketing.

FINANCIAL INSTITUTIONS

Litigation and bankruptcy checks for companies and debtors.

E-DISCOVERY AND LEGAL VENDORS

Sync your system to PACER to automate legal marketing.