

UNITED STATES PATENT AND TRADEMARK OFFICE

---

BEFORE THE PATENT TRIAL AND APPEAL BOARD

---

TRICKLESTAR LLC,  
Petitioner,

v.

EMBERTEC PTY LTD.,  
Patent Owner.

---

Case IPR2017-00839  
Patent 9,106,099 B2

---

Before BARBARA A. BENOIT, LYNNE E. PETTIGREW, and  
STACY B. MARGOLIES, *Administrative Patent Judges*.

MARGOLIES, *Administrative Patent Judge*.

DECISION  
Instituting *Inter Partes* Review and  
Denying Motion for Joinder  
*37 C.F.R. § 42.108*  
*37 C.F.R. § 42.122(b)*

## I. INTRODUCTION

TrickleStar LLC (“Petitioner”) filed a Petition for *inter partes* review of claims 8 and 10–16 of U.S. Patent No. 9,106,099 B2 (Ex. 1001, “the ’099 patent”). Paper 2 (“Pet.”). Embertec Pty Ltd. (“Patent Owner”) filed a Preliminary Response. Paper 10 (“Prelim. Resp.”). Institution of an *inter partes* review is authorized by statute when “the information presented in the petition . . . and any response . . . shows that there is a reasonable likelihood that the petitioner would prevail with respect to at least 1 of the claims challenged in the petition.” 35 U.S.C. § 314(a); *see* 37 C.F.R. § 42.108. Upon consideration of the Petition and the Preliminary Response, we conclude that the information presented shows that there is a reasonable likelihood that Petitioner would prevail in establishing the unpatentability of claims 8 and 10–16 of the ’099 patent.

Petitioner also filed a Motion for Joinder (Paper 3) and Patent Owner filed an Opposition to Petitioner’s Motion for Joinder (Paper 9). As explained below, we deny Petitioner’s Motion for Joinder.

### A. *Related Matters*

The parties identify one related proceeding that involves the ’099 patent: IPR2016-01336 (currently pending). *See* Pet. 1; Paper 7, 1.

### B. *The ’099 Patent*

The ’099 patent is directed to a system that monitors the electrical power supply to electrical equipment to reduce unnecessary power consumption. Ex. 1001, 1:14–18. The patent explains that “[m]onitoring can have many advantages, especially in detecting abnormal usage, faults and theft.” *Id.* at 2:60–61. For example, according to the ’099 patent, the system may detect excessive power consumption in an office due to use of a

portable heater and alert supervisory personnel to the abnormal energy usage. *Id.* at 2:62–67. The patent also describes alerting a user to cessation of power consumption, such as that caused by breakdown of a refrigerator or freezer. *Id.* at 3:1–4.

Figure 1 of the '099 patent, below, shows the components of energy saving device 12:

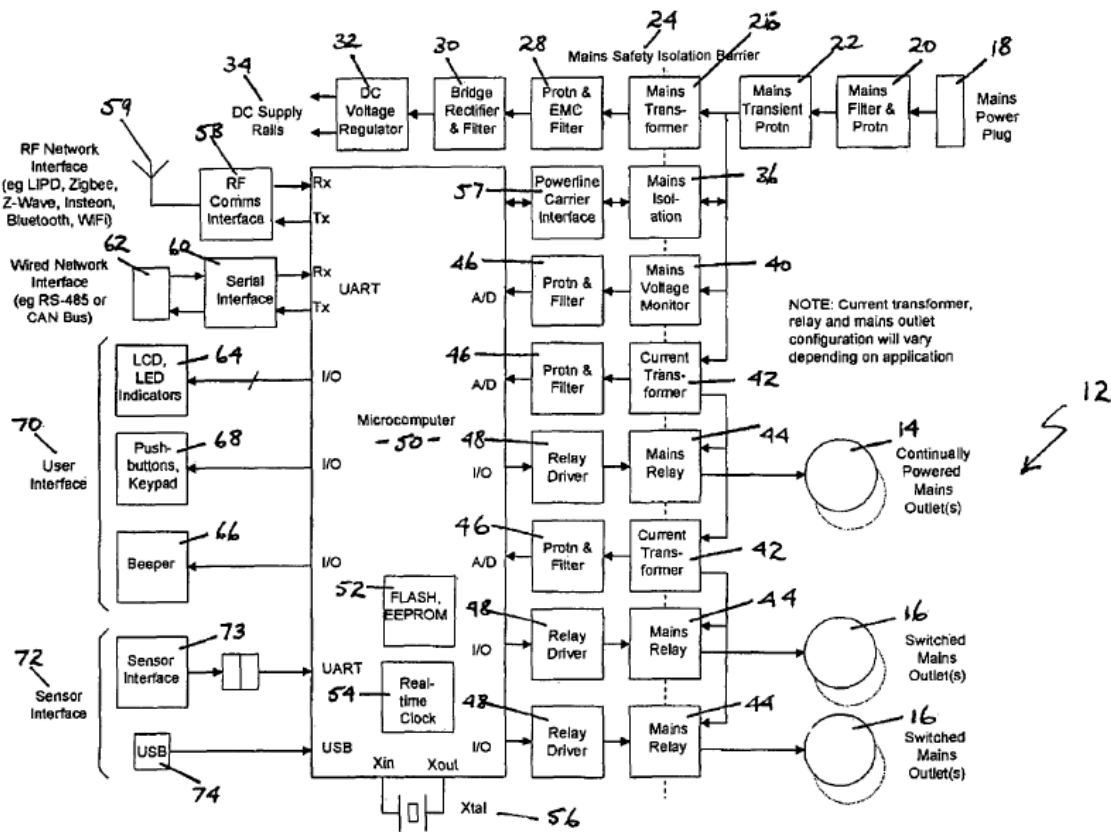

Figure 1

As illustrated in Figure 1 above, energy saving device 12 includes one or more continually powered mains outlets 14 and two or more switched mains outlets 16. *Id.* at 5:58–60. According to the patent, electrical devices (not shown) are plugged into mains outlets 14 and switched mains outlets 16 as required. *Id.* at 5:60–62. Energy saving device 12 also includes mains power plug 18 for connection to a mains power supply (not shown). *Id.* at

5:63–64. Microcomputer 50 implements energy saving algorithms and includes flash and/or EEPROM non-volatile memory 52 for storing energy saving configuration parameters. *Id.* at 6:56–64. User interface 70 includes LCD or LED indicators 64, beeper 66, and pushbuttons and keypad 68. *Id.* at 7:20–21. Sensor interface 72 provides an interface for an external sensor module (not shown) that includes a remote control infrared (IR) sensor for sensing IR remote control activity. *Id.* at 7:35–38.

### *C. Illustrative Claims*

Among the challenged claims, claims 10 and 12 are independent. Claims 8, 10, and 12, along with claim 1 from which claim 8 depends, are illustrative of the challenged claims and read as follows:

1. An energy saving device for reducing power consumption of an external electrical device, comprising:

an input *connectable* to an external power supply;

an output connectable to the external electrical device for selectively providing operating power thereto;

a processor for controlling when power is supplied to the external electrical device via the output; and

a sensor for monitoring wireless output signals of a remote control device that control functions of the external electrical device or another electrical device associated with the external electrical device, said sensor being coupled to the processor, and wherein the processor operates to terminate the power supplied to the external electrical device based upon the absence of the detection of the wireless output signals of the remote control device by the sensor.

8. The energy saving device of claim 1, further comprising a power sensor configured to sense power consumption of the external electrical device, the processor being further configured to determine an operational state of the external electrical device from the sensed power consumption

and to terminate the power supplied to the external electrical device when the external electrical device is determined to be in a selected state.

10. An energy saving device including

an electrical plug configured for connecting to a mains power supply;

an electrical socket configured for connecting to an electrical device;

a switch configured to control electrical connection between said electrical plug and said electrical socket;

a sensor configured to wirelessly sense activity of a user-operated remote control device, the activity configured to control said electrical device;

a control module configured to monitor the sensor to determine a first length of time during which said activity has not been detected and to operate said switch to disconnect electrical connection between the electrical plug and the electrical socket when said first length of time exceeds a threshold value to prevent the electrical device from drawing power during at least some times when no user is present and using the electrical device.

12. A system for monitoring power consumption of and controlling power supply to a plurality of electrical devices, the system including:

*communication apparatus for communicating with an energy saving device, the energy saving device having:*

a single electrical inlet configured to connect to a mains supply electrical outlet; and

a plurality of controlled electrical outlets for selectively supplying electrical power to the electrical devices; and

a power sensor for monitoring power consumption of at least one of the electrical devices connected to the controlled electrical outlets;

a processor configured to control the connection of electrical supply from the mains supply electrical outlet to each

# Explore Litigation Insights

Docket Alarm provides insights to develop a more informed litigation strategy and the peace of mind of knowing you're on top of things.

## Real-Time Litigation Alerts



Keep your litigation team up-to-date with **real-time alerts** and advanced team management tools built for the enterprise, all while greatly reducing PACER spend.

Our comprehensive service means we can handle Federal, State, and Administrative courts across the country.

## Advanced Docket Research



With over 230 million records, Docket Alarm's cloud-native docket research platform finds what other services can't. Coverage includes Federal, State, plus PTAB, TTAB, ITC and NLRB decisions, all in one place.

Identify arguments that have been successful in the past with full text, pinpoint searching. Link to case law cited within any court document via Fastcase.

## Analytics At Your Fingertips



Learn what happened the last time a particular judge, opposing counsel or company faced cases similar to yours.

Advanced out-of-the-box PTAB and TTAB analytics are always at your fingertips.

## API

Docket Alarm offers a powerful API (application programming interface) to developers that want to integrate case filings into their apps.

## LAW FIRMS

Build custom dashboards for your attorneys and clients with live data direct from the court.

Automate many repetitive legal tasks like conflict checks, document management, and marketing.

## FINANCIAL INSTITUTIONS

Litigation and bankruptcy checks for companies and debtors.

## E-DISCOVERY AND LEGAL VENDORS

Sync your system to PACER to automate legal marketing.