



US 20060013667A1

(19) **United States**

(12) **Patent Application Publication**
Ruan

(10) **Pub. No.: US 2006/0013667 A1**

(43) **Pub. Date: Jan. 19, 2006**

(54) **RAPID ROTATING DEVICE FOR RATCHET BELT SHAFT**

Jul. 14, 2004 (CN) 200420037526-9

(76) Inventor: **Bu Qin Ruan**, Zhejiang (CN)

Correspondence Address:
BERGMAN KUTA LLP
P. O. BOX 400167
CAMBRIDGE, MA 02140 (US)

Publication Classification

(51) **Int. Cl.**
B61D 45/00 (2006.01)
(52) **U.S. Cl.** **410/103**

(21) Appl. No.: **11/182,332**

(22) Filed: **Jul. 14, 2005**

(30) **Foreign Application Priority Data**

Jul. 14, 2004 (CN) 200410052805-7

(57) **ABSTRACT**

A ratchet mechanism for a cargo tie-down includes a unidirectional coupling. The unidirectional coupling is adapted to receive a bidirectional torque at an input thereof, and provide a unidirectional torque to a belt shaft at an output thereof.

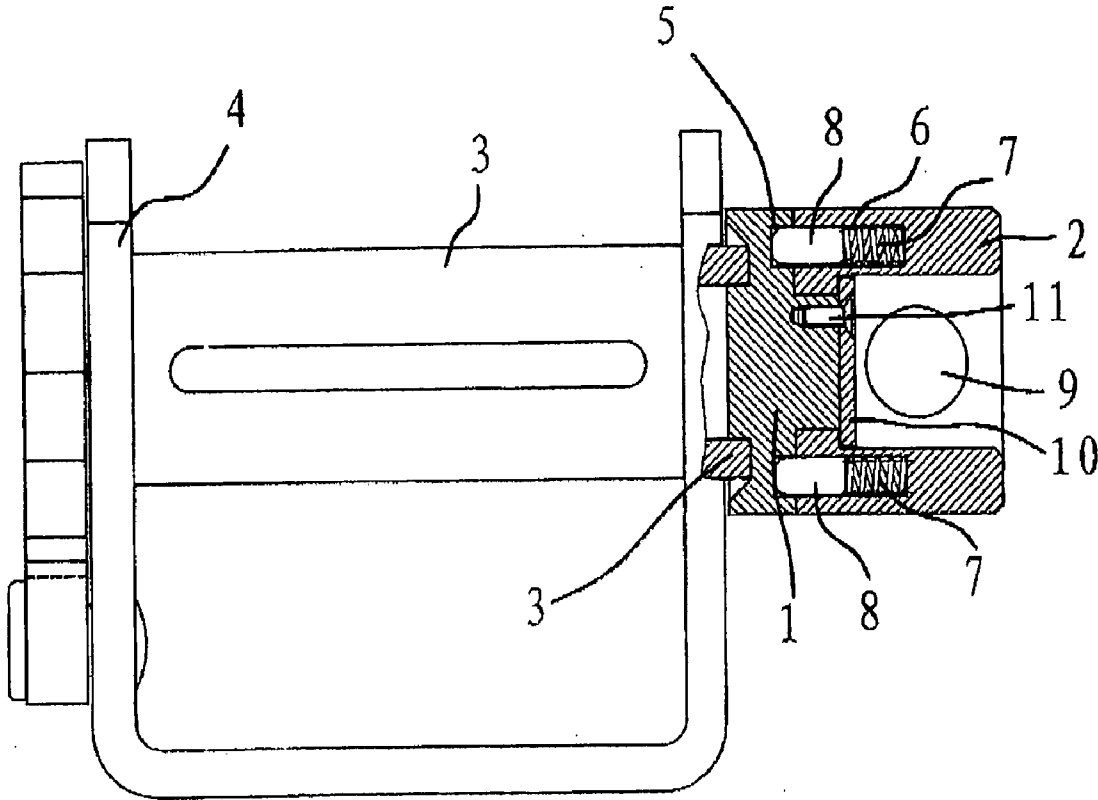

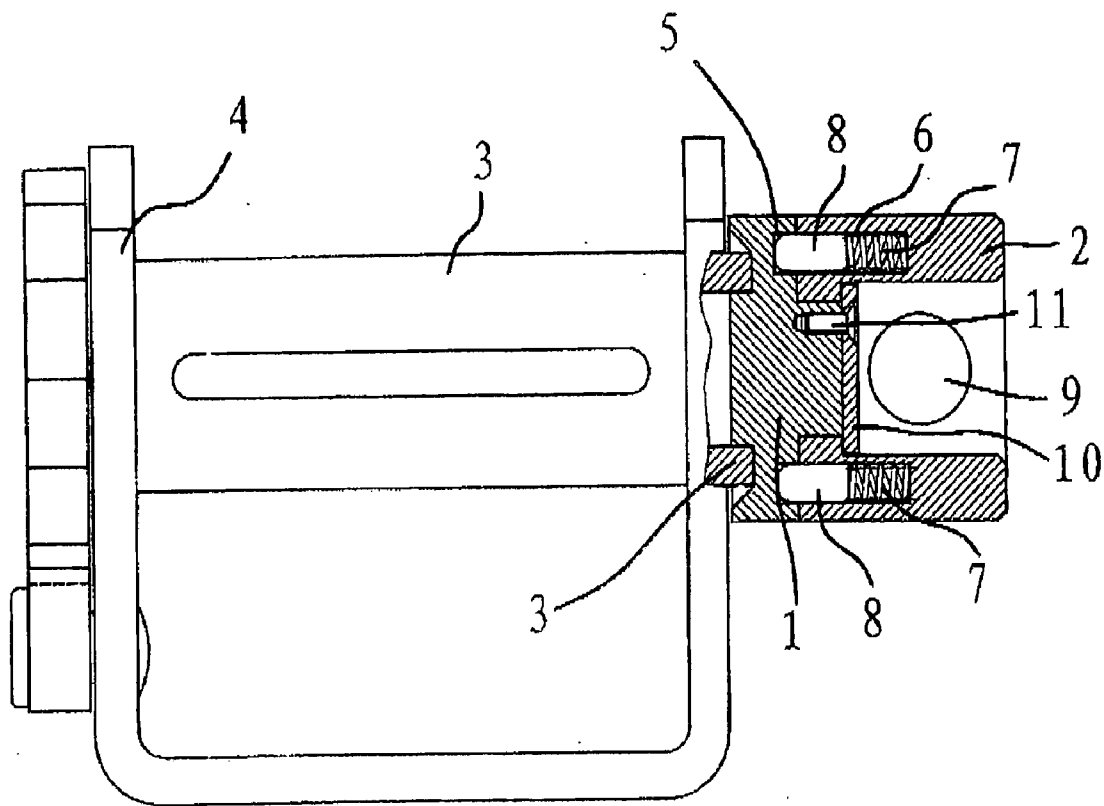

Figure 1

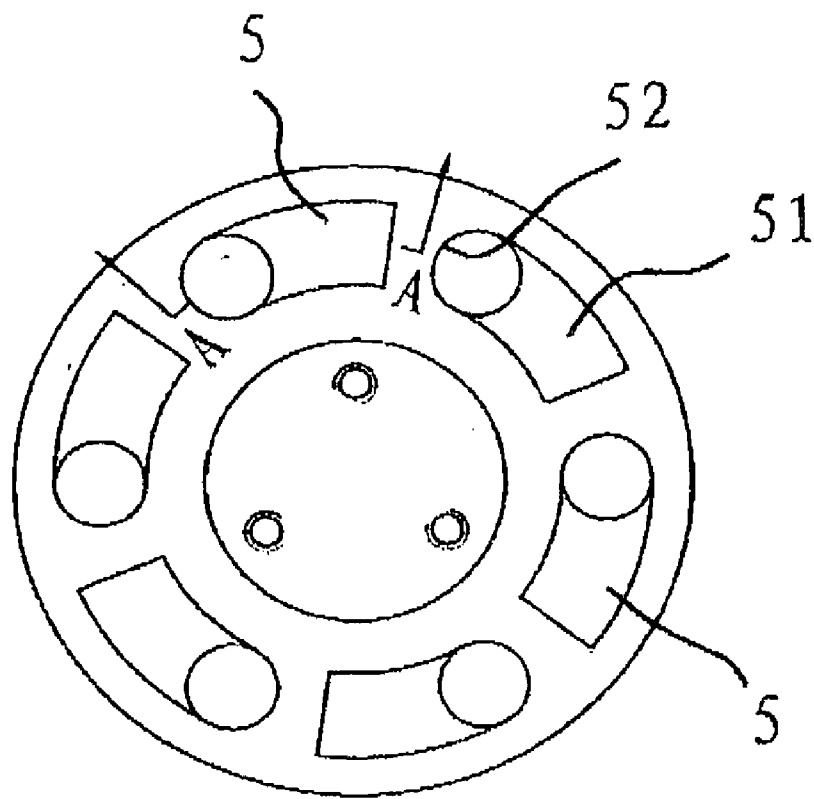

Figure 2

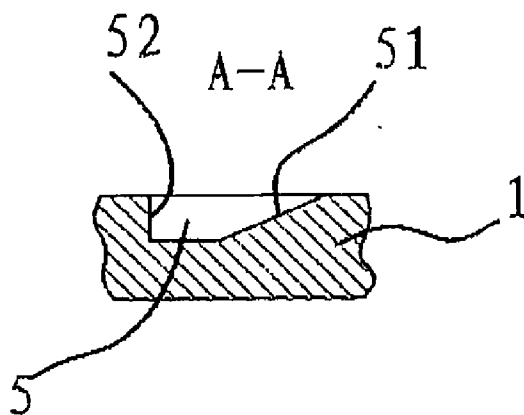

Figure 3

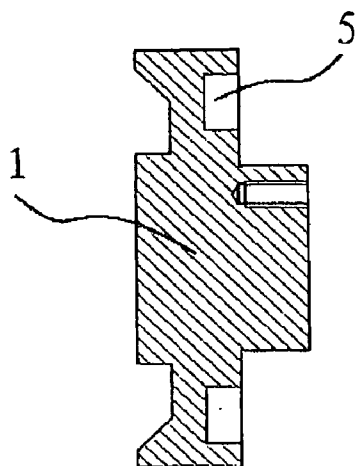

Figure 4

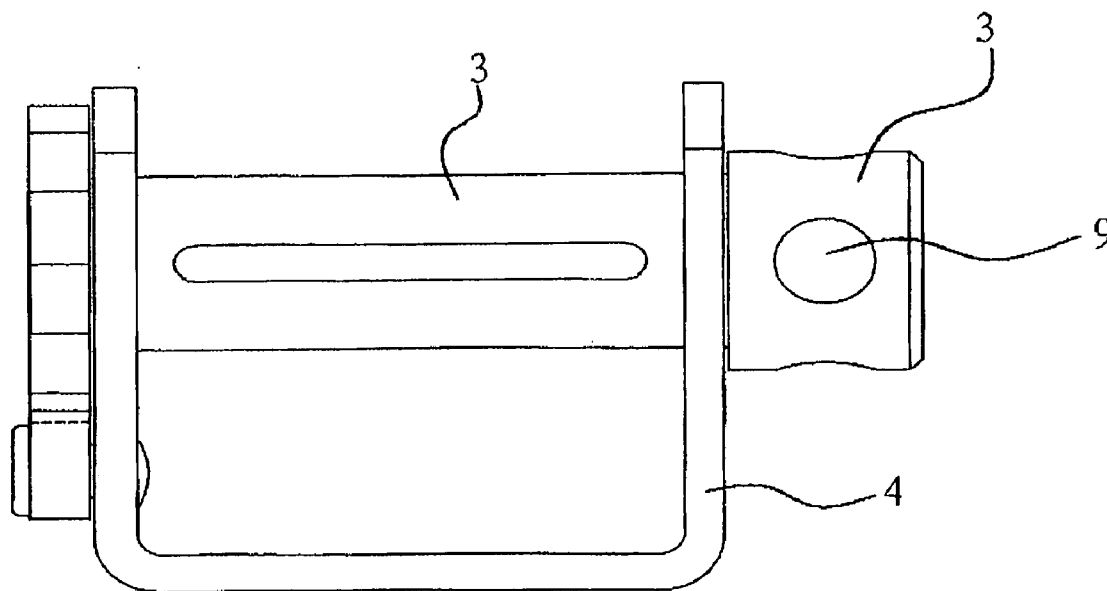

Figure 5

RAPID ROTATING DEVICE FOR RATCHET BELT SHAFT

CROSS-REFERENCE TO RELATED APPLICATIONS

[0001] The present application claims priority to Chinese patent application numbers 200410052805-7 and 200420037526-9, both filed Jul. 14, 2004, the disclosures of which are herewith incorporated by reference in their entirety.

FIELD OF THE INVENTION

[0002] The present invention relates to a tie-down, and more particularly to a ratchet tie-down.

BACKGROUND

[0003] When goods are transported by automobile, the goods need to be secured to prevent the goods from falling off the automobile, or colliding with one another to induce damage. It is a common practice to tie goods down to the bed of a truck with ropes. This may be a time consuming process, however. Tying with ropes requires a lot of effort, and it is difficult to secure the goods properly.

[0004] A ratchet is an advanced tying tool. Ratchets have been well received among truck drivers due to their ease of use and to safety concerns when otherwise tying down the goods. As shown in FIG. 5, there is a frame 4 and belt shaft 3 on the ratchet with belt shaft 3 located on the frame 4. The belt shaft can be turned. The tie-down belt is then wrapped around the belt shaft 3, and can be tightened when turning the belt shaft 3, so as to retract the belt.

[0005] The current method of tying involves turning the belt shaft 3 by using a crowbar to stick through a crowbar hole 9. Due to the fact that the ratchet is attached to the truck bed, it is necessary to remove the crowbar from the crowbar hole 9 after the belt shaft 3 has been turned through a certain angle, and re-insert the crowbar into the crowbar hole at a different angle.

[0006] Obviously, this is a slow process, and it takes a lot of effort. In the meantime, it is possible to cause harm to fingers or other body parts due to frequent insertions and removals of the crowbar.

SUMMARY OF THE INVENTION

[0007] The present invention resolves many of the issues mentioned above. This invention provides a rapid rotating device such that it will not be necessary to remove and insert the crowbar during operation. Thus easy, effortless operation is achieved, and tie-down speed is increased while ensuring safe and reliable operation.

[0008] This invention is realized through the following technical solutions: the rapid rotating device for use with the ratchet belt shaft is arranged on a side of the belt shaft that is next to the ratchet frame. The characteristics of the rapid rotating device are: the device includes a fixed base and a rotating body. The fixed base is attached firmly to the belt shaft, and the rotating device is fit circumferentially around the fixed base on one side. A unidirectional link-drive mechanism is located at the contacting surface between the

[0009] In the aforementioned ratchet belt shaft rapid rotating device, the unidirectional link-drive mechanism includes several spring holes located at the contacting surface between the rotating body and the fixed base. Each spring hole includes one spring and a push-pin. The pushpin is adapted to push against the side of the fixed base due to spring force. An equal number of aligned slide grooves are located on the side of the fixed base. One side of each slide groove is inclined toward the direction of rotation of the rotating device, and extended to a side surface of the fixed base, while the other side of each groove is disposed perpendicular to the side surface of the fixed base.

[0010] While turning the rotating body toward the inclined surfaces of the slide grooves during usage, the pushing-pins will slide up along the inclined side of the grooves, and push the pushing-pins into the spring holes until the pushing-pins slide onto the side surface of the fixed base. The pushing-pins will fall into the next slide grooves if the rotating body is turned further, and the whole slide-up-fall-in action of the pushing-pins will be repeated. Obviously, turning the rotating body in one direction will not drive the belt shaft since the fixed base is not turned by the rotating body.

[0011] On the other hand, if turning the rotating body in the reverse direction, the pushing-pins will be stopped by the perpendicular side of the slide grooves after sliding into the grooves. Thus the rotating body will be unable to turn further without turning the fixed base. This results in a link-drive relationship between the fixed base and rotating body. Under the turning moment of the rotating body, the fixed base will follow accordingly and thus drive the belt shaft.

[0012] When applying the rotating device toward the ratchet, it is necessary to ensure the direction of rotation of the link-drive mechanism, between fixed base and the rotating body, is the same as the tightening direction of the belt shaft. Thus it is only necessary to turn the crowbar back and forth, after putting the crowbar into the crowbar hole on the rotating body, to tighten the belt. Since the fixed base can only rotate unidirectionally, this back-and-forth motion will be enough to tighten the belt. After the tightening is complete, simply remove the crowbar from the hole.

[0013] Compared to the current method of inserting a crowbar directly into a bore in the end of the belt shaft, a ratchet utilizing the rapid rotating device of the invention possesses benefits such as safe, reliable and effortless operation; no need to remove and re-insert the crowbar, and won't harm the product or the operator. In the meantime, there is no restriction on the latitude of forward and backward motion on the crowbar, which increases the ease of use of the ratchet, and improves the speed of tying, resulting in higher practical value.

BRIEF DESCRIPTION OF THE DRAWINGS

[0014] FIG. 1 is a mechanical schematic of the rapid rotating device for a ratchet;

[0015] FIG. 2 is a side-view diagram of a fixed base for a rapid rotating device;

[0016] FIG. 3 is a cross-section diagram along A-A line in FIG. 2;

[0017] FIG. 4 is a cross-section diagram along B-B line in FIG. 1;

Explore Litigation Insights

Docket Alarm provides insights to develop a more informed litigation strategy and the peace of mind of knowing you're on top of things.

Real-Time Litigation Alerts



Keep your litigation team up-to-date with **real-time alerts** and advanced team management tools built for the enterprise, all while greatly reducing PACER spend.

Our comprehensive service means we can handle Federal, State, and Administrative courts across the country.

Advanced Docket Research



With over 230 million records, Docket Alarm's cloud-native docket research platform finds what other services can't. Coverage includes Federal, State, plus PTAB, TTAB, ITC and NLRB decisions, all in one place.

Identify arguments that have been successful in the past with full text, pinpoint searching. Link to case law cited within any court document via Fastcase.

Analytics At Your Fingertips



Learn what happened the last time a particular judge, opposing counsel or company faced cases similar to yours.

Advanced out-of-the-box PTAB and TTAB analytics are always at your fingertips.

API

Docket Alarm offers a powerful API (application programming interface) to developers that want to integrate case filings into their apps.

LAW FIRMS

Build custom dashboards for your attorneys and clients with live data direct from the court.

Automate many repetitive legal tasks like conflict checks, document management, and marketing.

FINANCIAL INSTITUTIONS

Litigation and bankruptcy checks for companies and debtors.

E-DISCOVERY AND LEGAL VENDORS

Sync your system to PACER to automate legal marketing.