



US005314275A

**United States Patent** [19]  
**Cottrell et al.**

[11] **Patent Number:** **5,314,275**  
[45] **Date of Patent:** **May 24, 1994**

- [54] **SAFETY TIE-DOWN ROLLER**
- [75] **Inventors:** **D. Michael Cottrell; Don J. Cottrell,**  
both of Gainesville, Ga.
- [73] **Assignee:** **Cottrell, Inc.,** Gainesville, Ga.
- [21] **Appl. No.:** **874,395**
- [22] **Filed:** **Apr. 27, 1992**
- [51] **Int. Cl.<sup>5</sup>** ..... **B60P 3/079**
- [52] **U.S. Cl.** ..... **410/26; 410/12;**  
410/103
- [58] **Field of Search** ..... **410/11, 12, 26, 100,**  
410/102, 103

*Primary Examiner*—Michael S. Huppert  
*Assistant Examiner*—Gregory A. Morse  
*Attorney, Agent, or Firm*—James A. Hinkle

[57] **ABSTRACT**

A safety tie-down roller (1) has a spring laden ratchet pawl (9) positioned at an opposite side of structural framework (11) from a ratchet gear (8) and its related working conditions. A handle (33, 34, 35) is provided to release the ratchet pawl (9) against pressure of a spring (20, 37, 40, 42) for unloading cars and for straightening out chain to prevent loosening hazards. A wrench socket (45, 46, 51) is provided in addition to bar wrench apertures (15) for fast ratchet wrench rotation or optionally for motorized wrench rotation of the tie-down ratchet gear (8). Accurate torque control is made possible by the wrench sockets with either a hand torque wrench or a motorized torque wrench. Adapter plates (47, 49) are provided in addition to convenient forms of special hand wrenches (57, 58, 60). A non-lubricated hard bearing (26-29) for a tie-down rod (7) is attachable to car ramp structural members (12) of carrier vehicles (3, 4) without adversely affecting metal temper or causing distortion hard bearing surfaces (26, 27) from welding heat.

[56] **References Cited**

**U.S. PATENT DOCUMENTS**

3,157,133	11/1964	Wojcikowski	410/12
3,187,686	6/1965	De Podesta	410/12
3,589,304	6/1971	Haynes	410/12
3,827,662	8/1974	Krokos	410/12
3,860,263	1/1975	Taylor	410/12
4,234,166	11/1980	Cederblad	410/103
4,273,484	6/1981	Blanar	410/12
4,273,486	6/1981	Tatina	410/12
5,145,299	9/1992	Stephenson, Jr.	410/100
5,156,506	10/1992	Bailey	410/100
5,180,262	1/1993	Westerdale	410/12

**15 Claims, 7 Drawing Sheets**

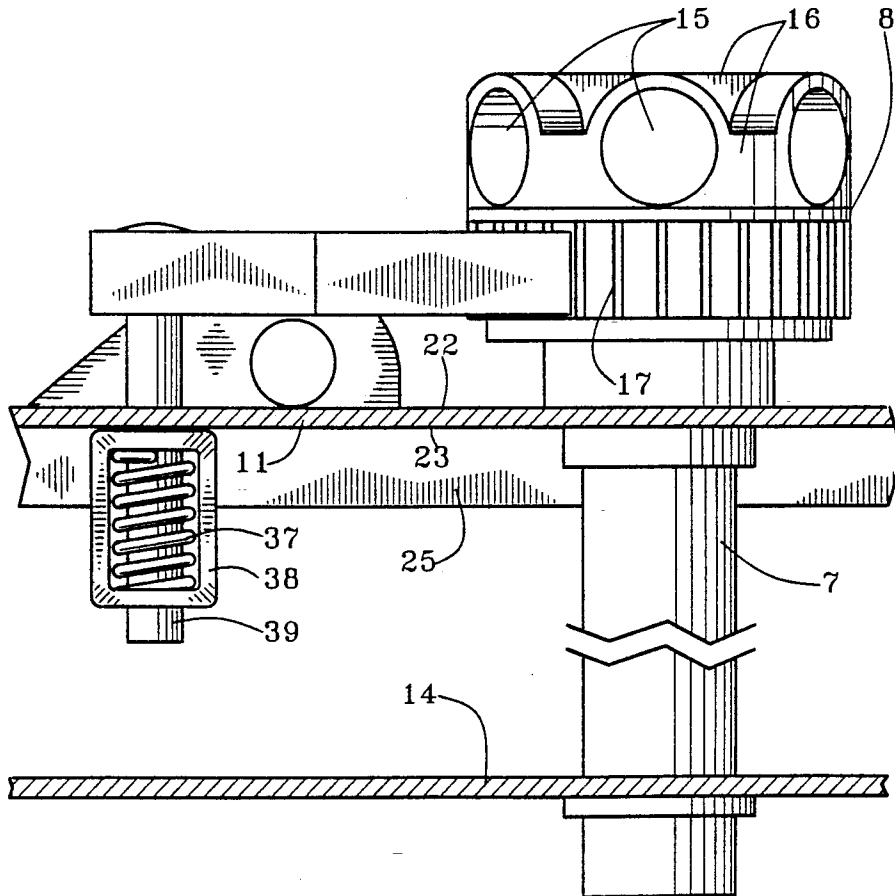

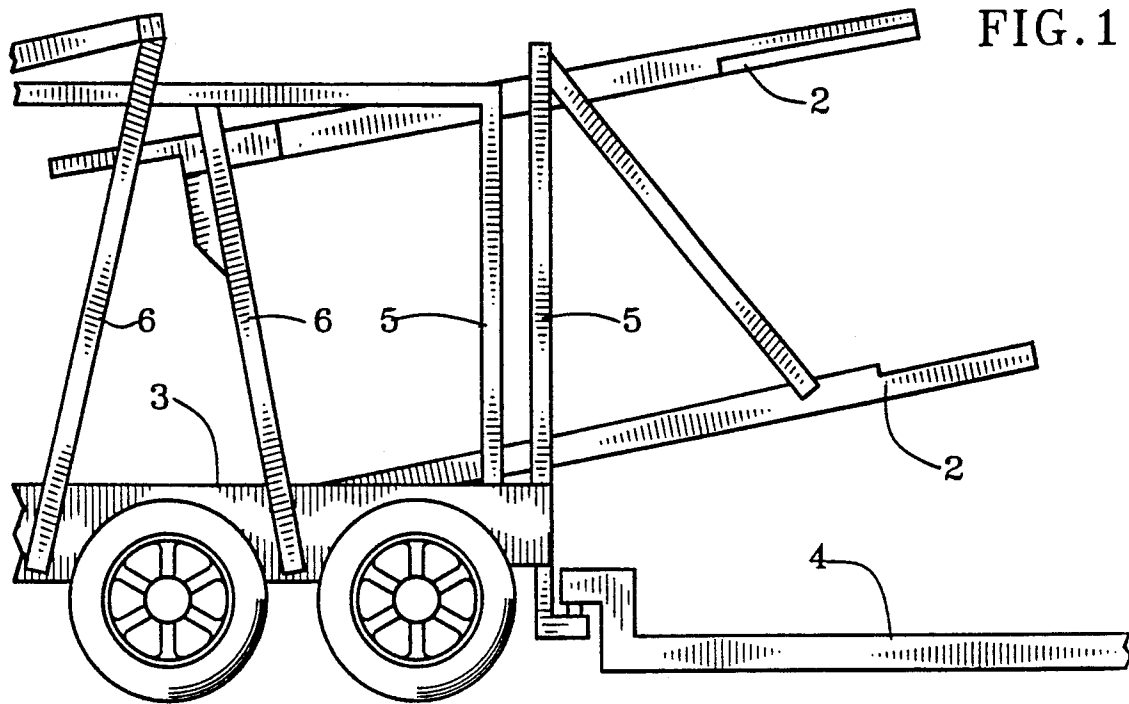

FIG. 1

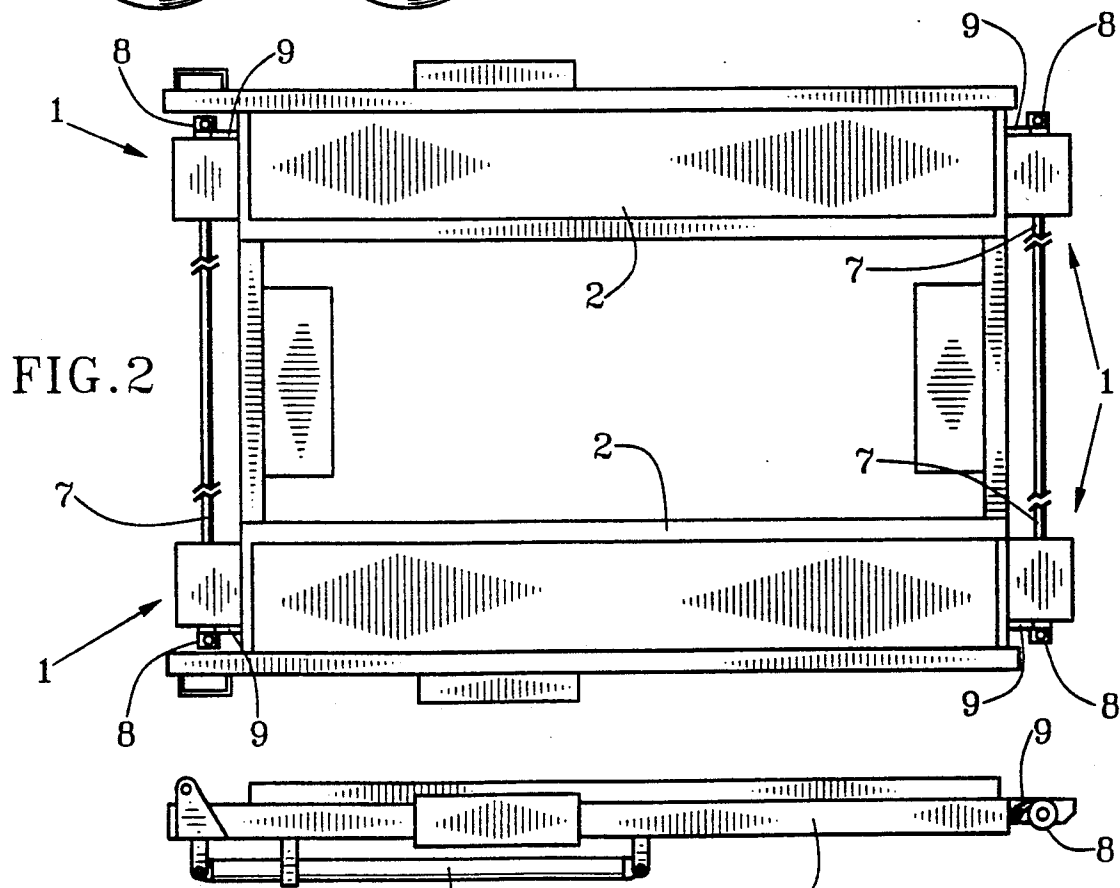

FIG. 2

FIG. 3

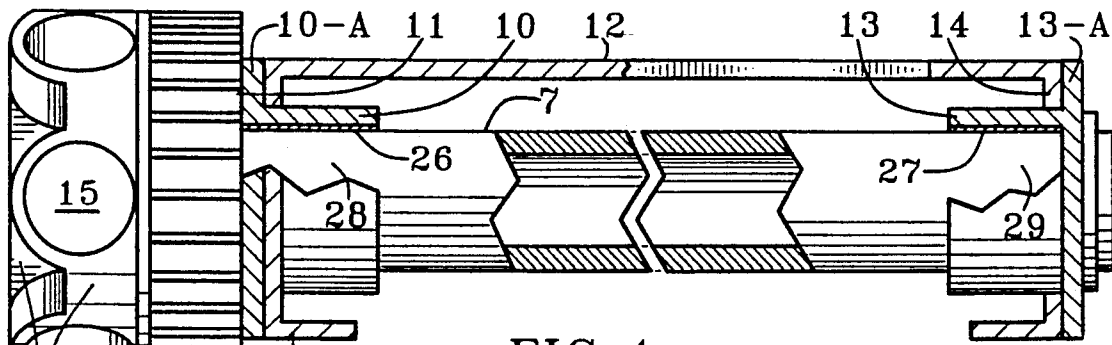

FIG. 4

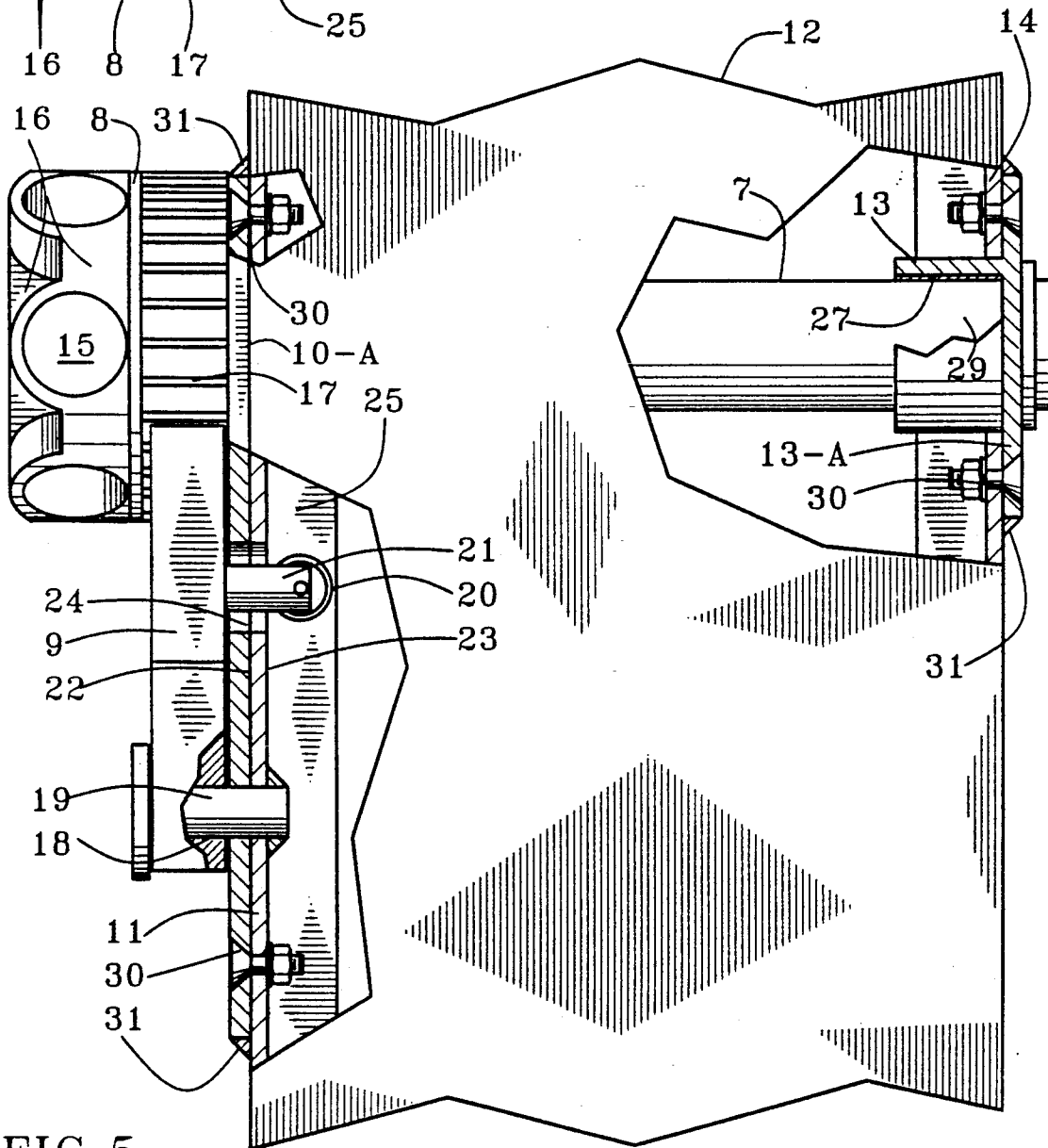

FIG. 5

FIG. 6

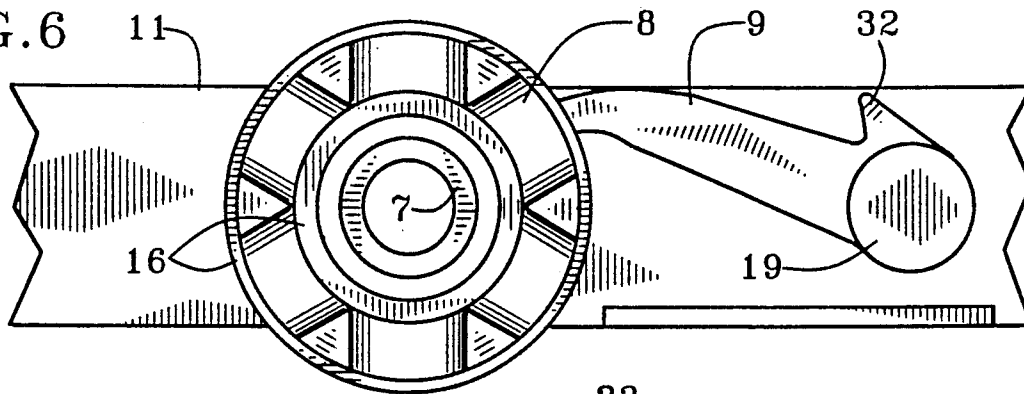

FIG. 7

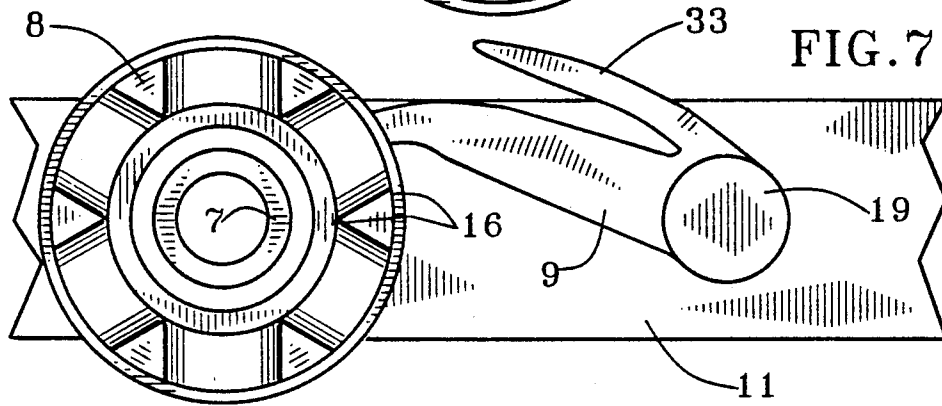

FIG. 8

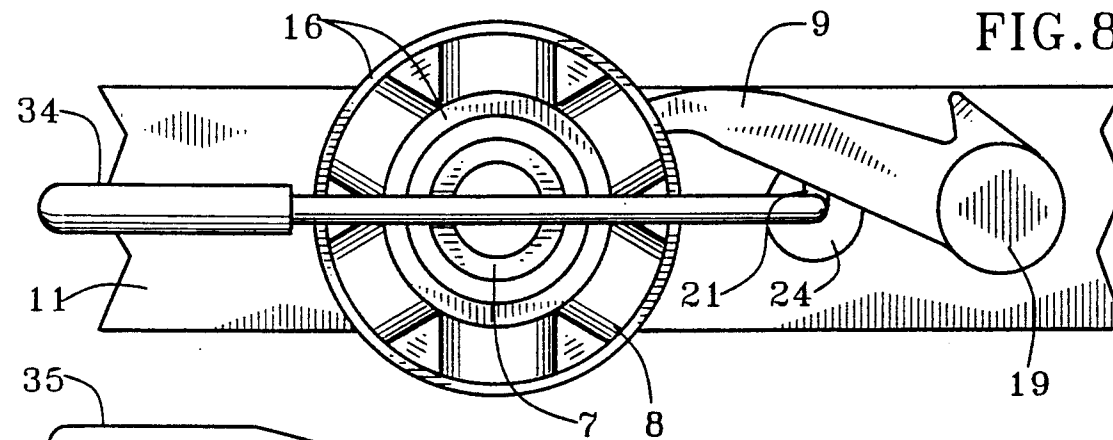

FIG. 9

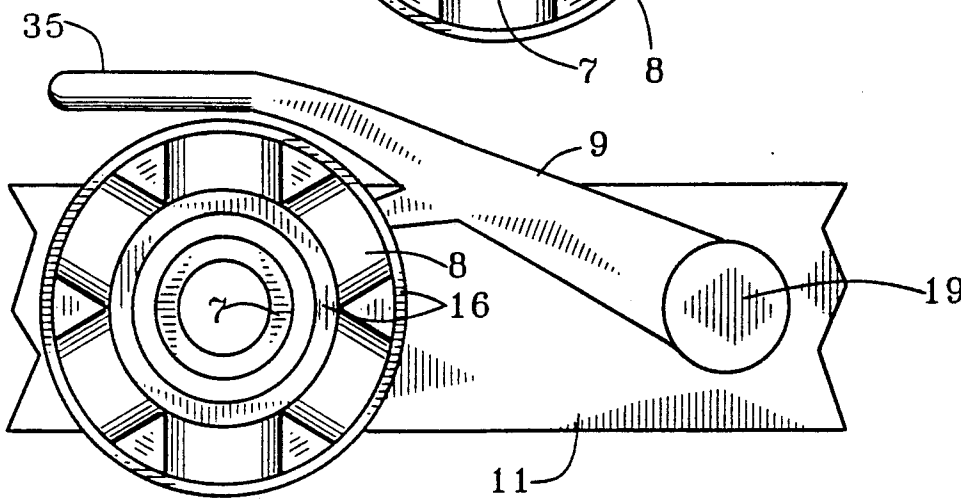

FIG. 10

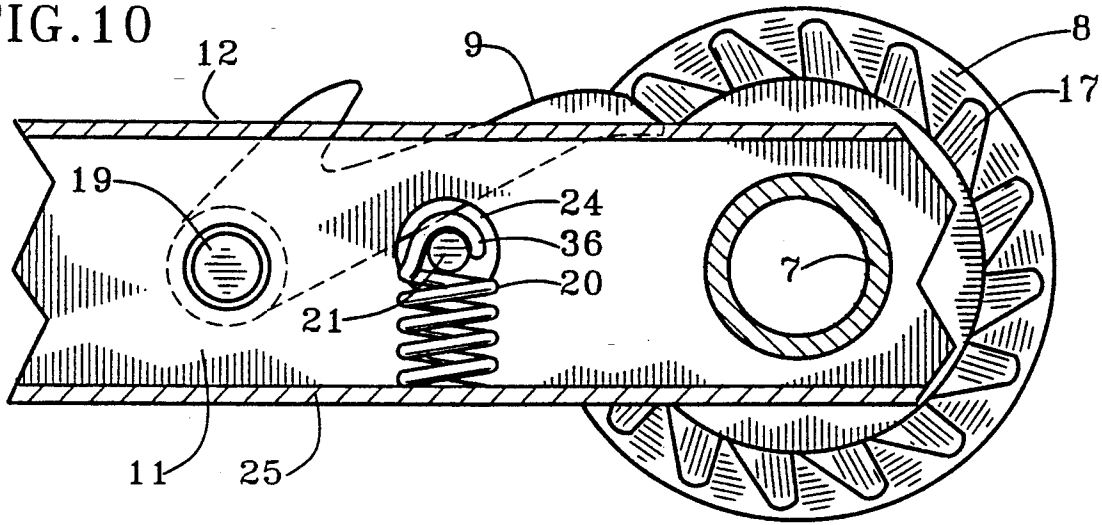
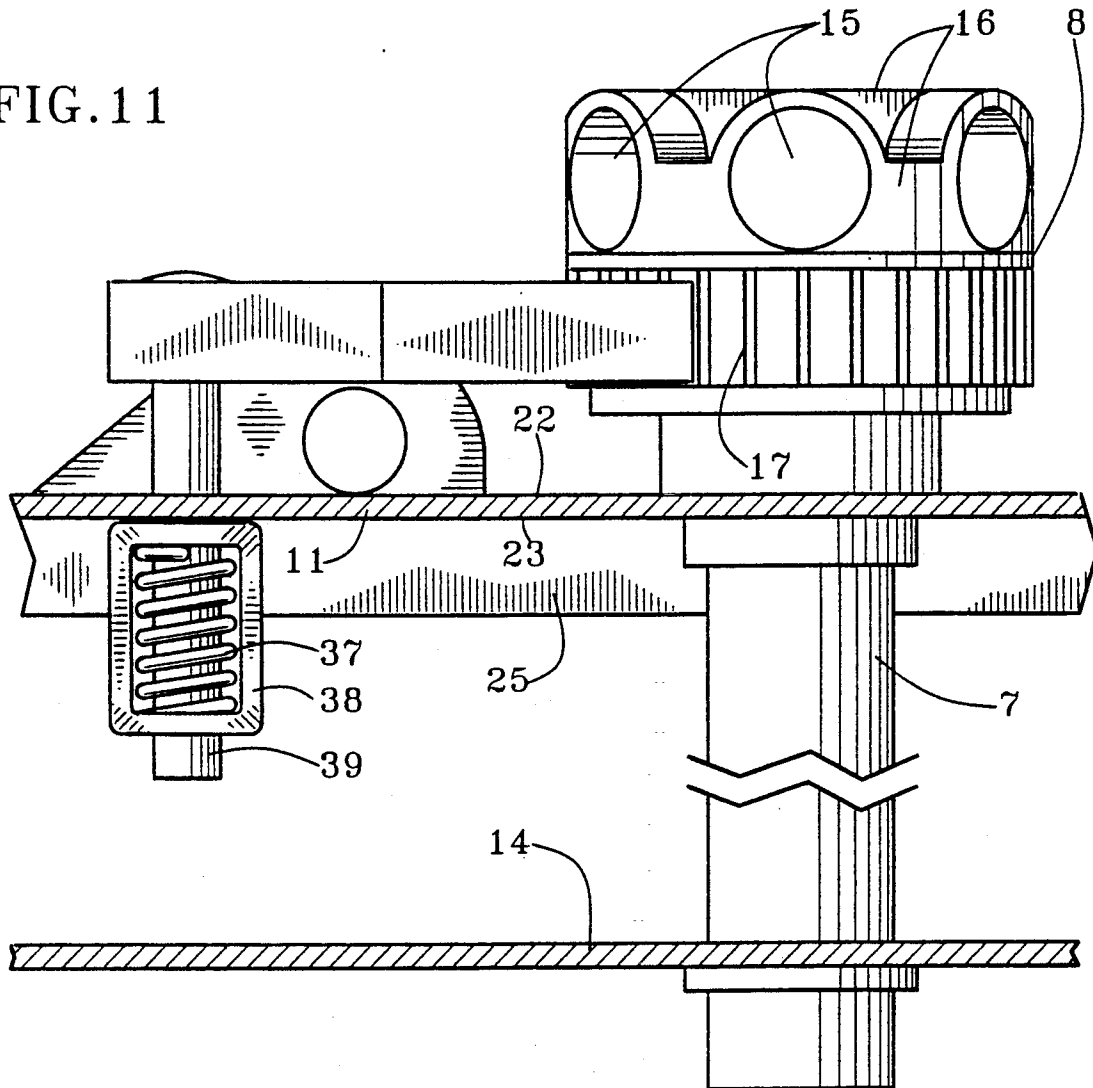

FIG. 11



# Explore Litigation Insights

Docket Alarm provides insights to develop a more informed litigation strategy and the peace of mind of knowing you're on top of things.

## Real-Time Litigation Alerts



Keep your litigation team up-to-date with **real-time alerts** and advanced team management tools built for the enterprise, all while greatly reducing PACER spend.

Our comprehensive service means we can handle Federal, State, and Administrative courts across the country.

## Advanced Docket Research



With over 230 million records, Docket Alarm's cloud-native docket research platform finds what other services can't. Coverage includes Federal, State, plus PTAB, TTAB, ITC and NLRB decisions, all in one place.

Identify arguments that have been successful in the past with full text, pinpoint searching. Link to case law cited within any court document via Fastcase.

## Analytics At Your Fingertips



Learn what happened the last time a particular judge, opposing counsel or company faced cases similar to yours.

Advanced out-of-the-box PTAB and TTAB analytics are always at your fingertips.

## API

Docket Alarm offers a powerful API (application programming interface) to developers that want to integrate case filings into their apps.

## LAW FIRMS

Build custom dashboards for your attorneys and clients with live data direct from the court.

Automate many repetitive legal tasks like conflict checks, document management, and marketing.

## FINANCIAL INSTITUTIONS

Litigation and bankruptcy checks for companies and debtors.

## E-DISCOVERY AND LEGAL VENDORS

Sync your system to PACER to automate legal marketing.