



US005101537A

United States Patent [19]

[11] Patent Number: **5,101,537**

Cummings

[45] Date of Patent: **Apr. 7, 1992**

[54] **RATCHET TIE-DOWN**

[75] Inventor: **David S. Cummings**, Princeton, Mass.

[73] Assignee: **Lowell Corporation**, Worcester, Mass.

[21] Appl. No.: **561,005**

[22] Filed: **Aug. 1, 1990**

Primary Examiner—James R. Brittain
Attorney, Agent, or Firm—Shlesinger, Arkwright & Garvey

[57] **ABSTRACT**

A ratchet tie down structure is shown that is designed to hold heavy objects in place on a transport vehicle such as a flat bed trailer, a car carrier, a railroad car and the like. The mechanism includes a base element attached to the transport vehicle that has pair of cooperating elements having interfitting ratchet teeth and a latch that permit a shaft to be turned in one direction to tighten a flexible holding element attached to the object with the latch holding the tension therein until the ratchet teeth on the two elements are disengaged. The structure includes a driving connection by which the shaft may be rotated in one direction to wind a tension in the flexible holding element and the latch being selectively operative to disengage one of the elements with the ratchet teeth from the other in order to release the tension in the flexible holding means when the heavy object is to be unloaded.

Related U.S. Application Data

[63] Continuation-in-part of Ser. No. 260,001, Oct. 19, 1988, abandoned.

[51] Int. Cl.⁵ **A44B 21/00**

[52] U.S. Cl. **24/68 CD; 24/71.2**

[58] Field of Search **24/68 R, 68 CD, 68 SK, 24/68 B, 71.2, 68 CT; 410/100**

[56] **References Cited**

U.S. PATENT DOCUMENTS

- 3,988,007 10/1976 Freiburger, Jr. 24/68 R
- 4,045,002 8/1977 Miller 24/68 CD X
- 4,234,166 11/1980 Cederblad 24/68 CD
- 4,799,297 1/1989 Baggio et al. 24/68 SK

7 Claims, 3 Drawing Sheets

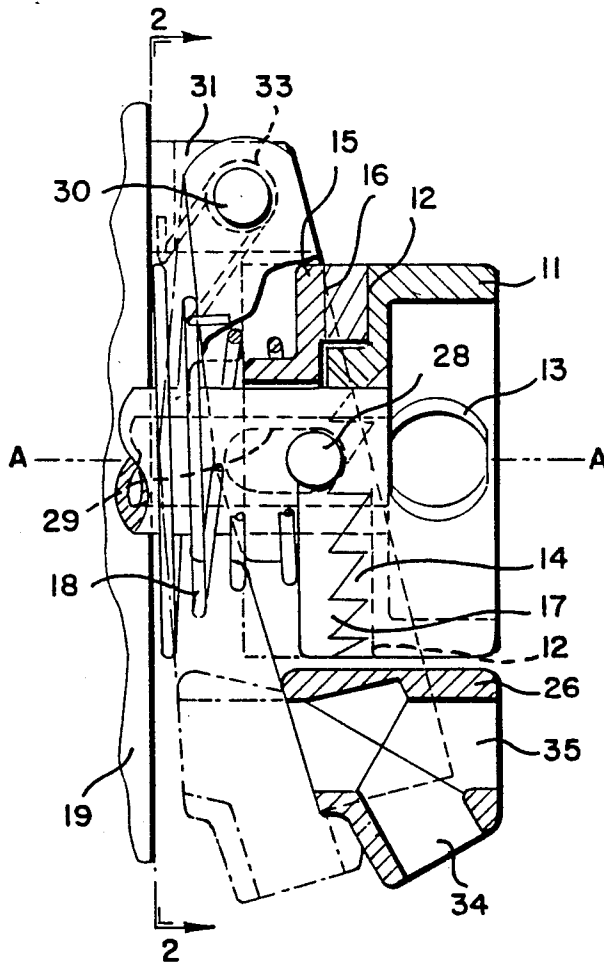

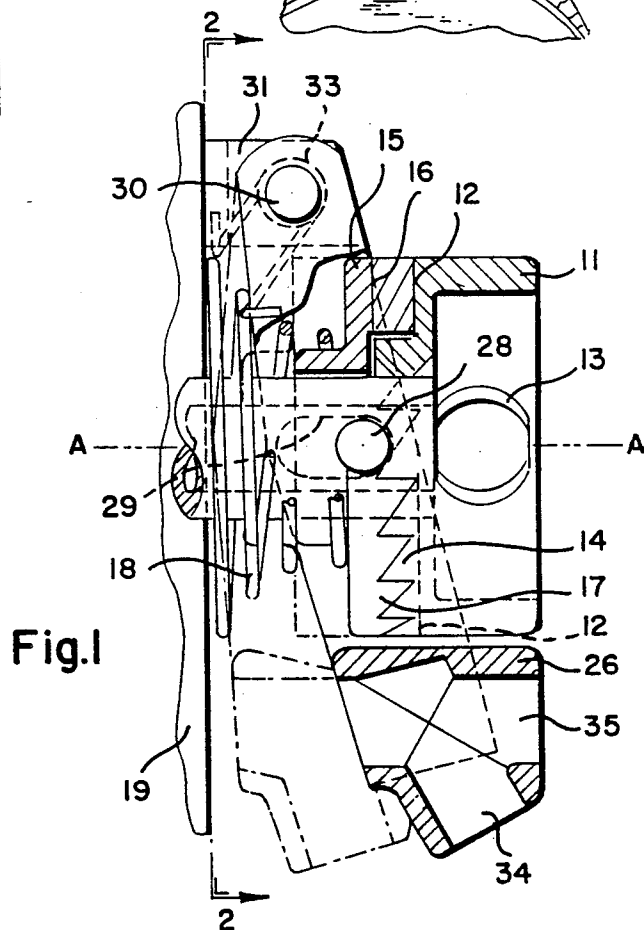
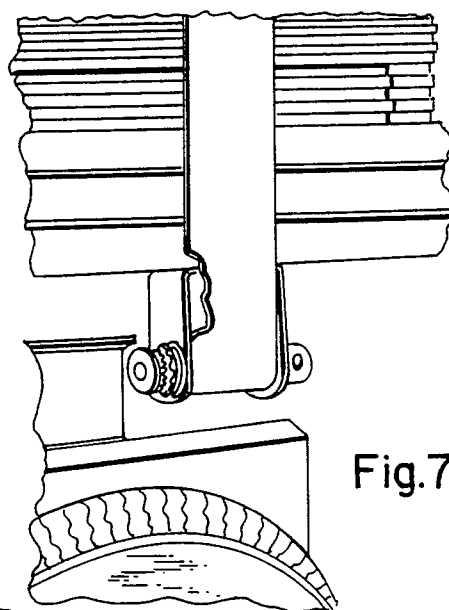
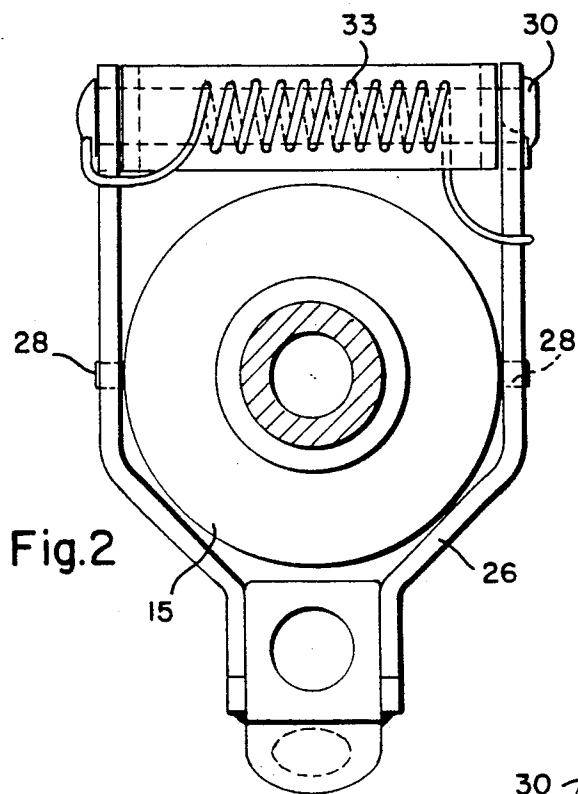

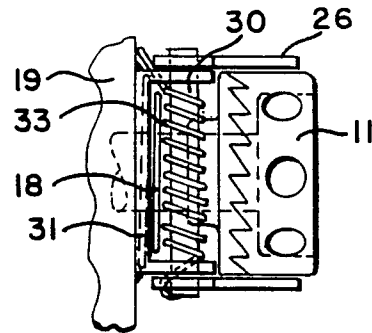
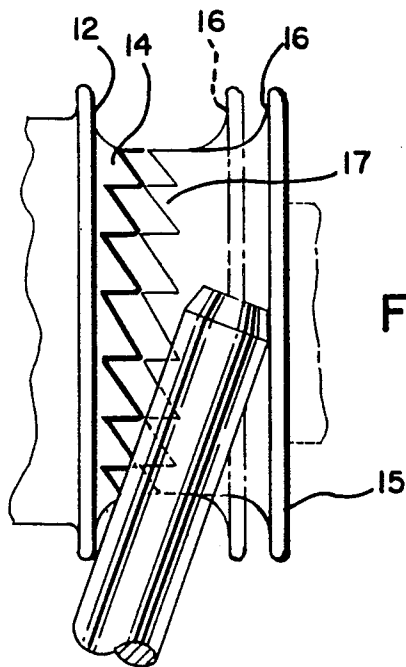
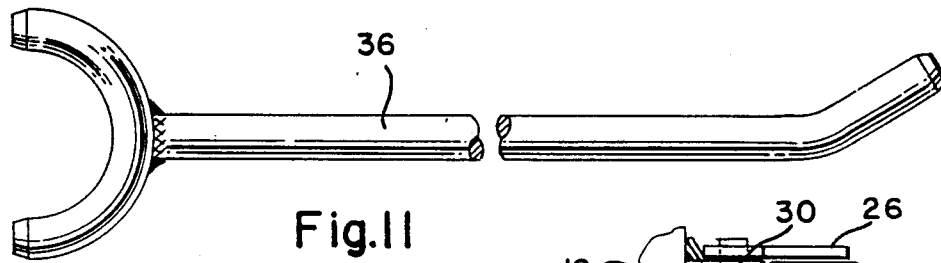
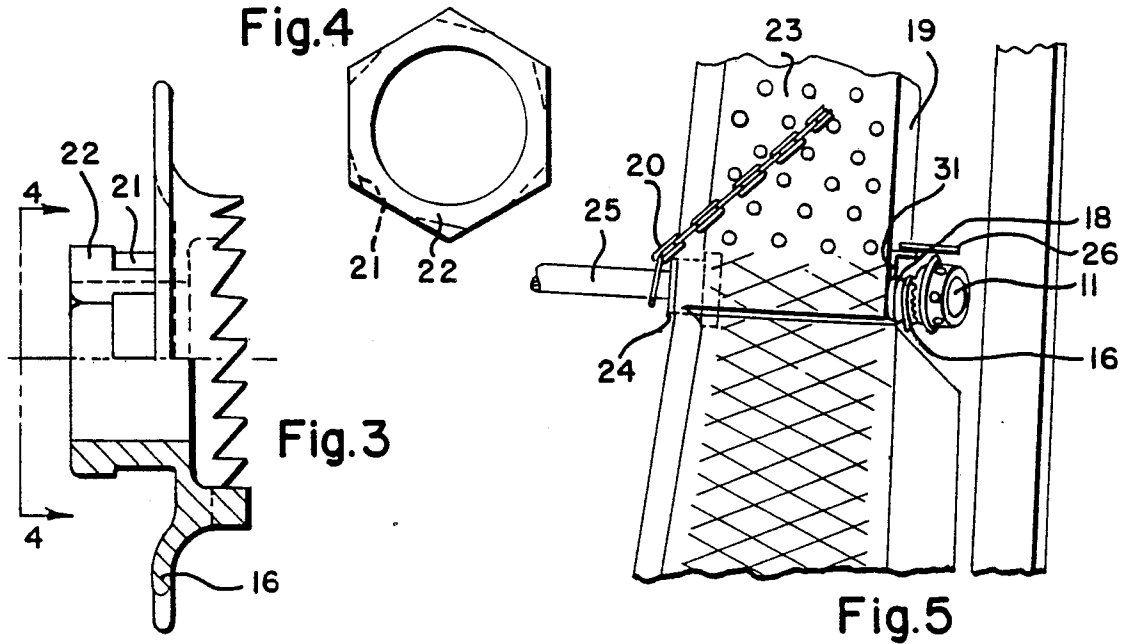

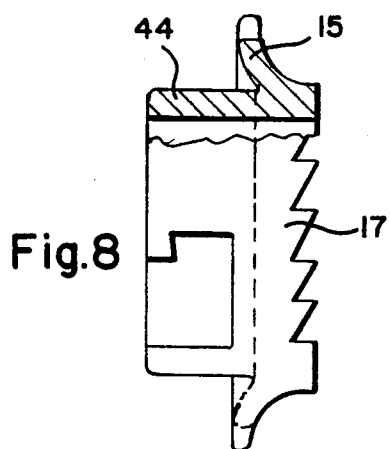
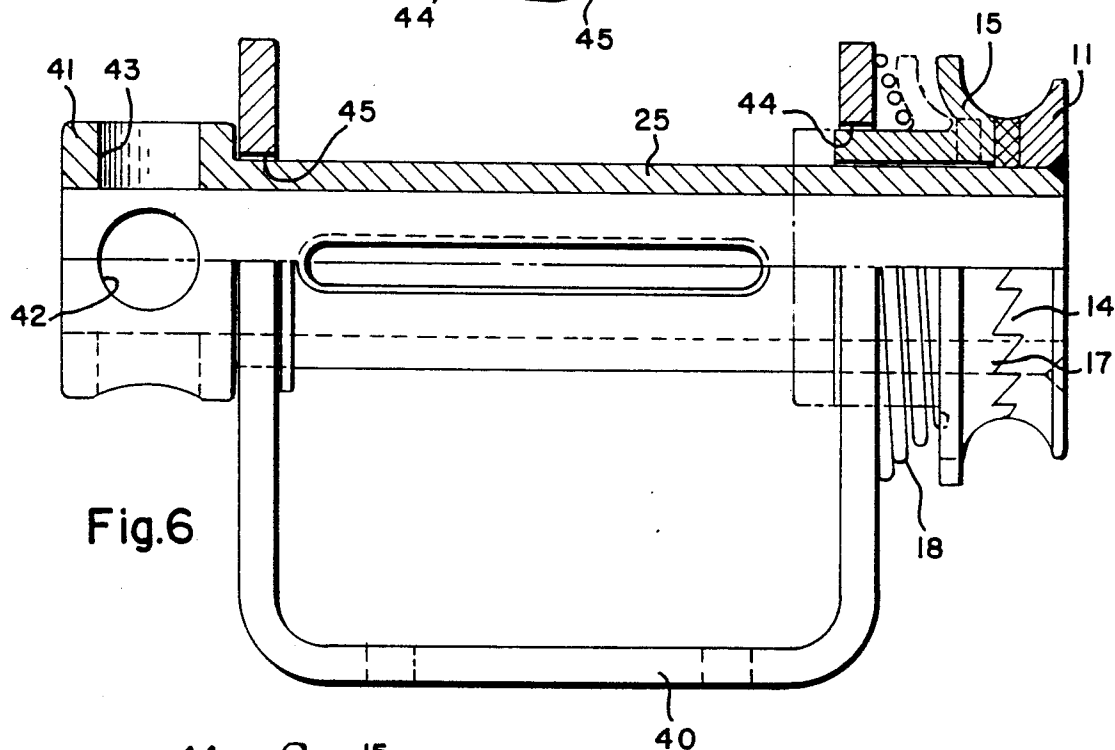
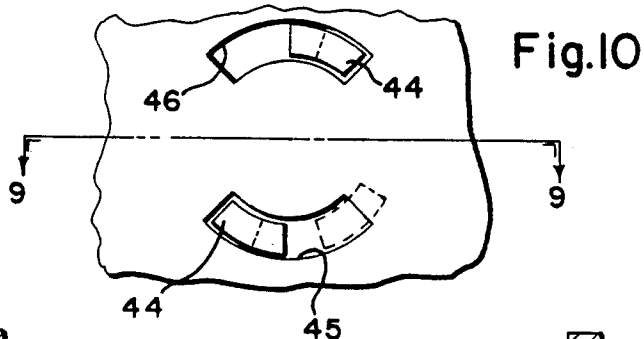
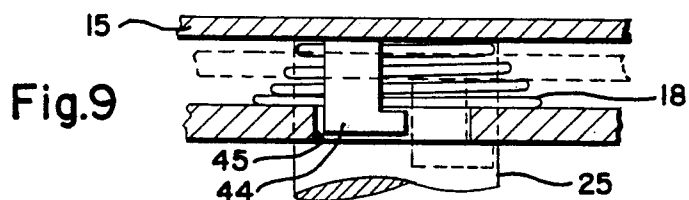

RATCHET TIE-DOWN

This is a continuation-in-part of my application Ser. No. 07/260,001, filed Oct. 19, 1988, abandoned, for Ratchet.

This invention relates to a means for anchoring objects to be transported onto the flat beds or decks of transport vehicles such as auto transport trailers, flat bed trucks and trailers, railroad flat cars by tensioning a flexible strap or chain or the like around the object to fasten it to the transport means.

BACKGROUND

In the transport or freight hauling industry there is a need for means to quickly and easily apply a suitable tension to chains, straps, cables and ropes that are adapted to fix heavy objects in place on the transport means. The device for pulling the tension in the flexible means must also be constructed and arranged to hold the tension in the flexible tie-down while the objects are being transported and yet that device must be adapted to be quickly and safely operative to release the tension in the flexible tie-down means for unloading the objects when the destination has been reached.

Heretofore, one form of a tie-down system has been used which makes use of a manually manipulated rotating take up shaft for wrapping a flexible tie-down means around its periphery, the shaft having a toothed wheel integral therewith that coacts with a pawl to hold the tension in the flexible tie-down. A suitable winding or cranking means is provided to wind the flexible tie-down on the shaft and the pawl must be released at the destination to permit the unloading of the heavy object from the transport. In practice at the freight depot, the tension in the tie-down is released by using a pry bar or a crank on the toothed wheel to slightly tighten the flexible tie-down in order to release the load on the pawl and then the operator can move the pawl to its unlocked position whereupon the toothed wheel can be turned to reverse the rotation of the shaft to fully release the pull on the tie-down. The use of the fingers near the pawl adjacent the toothed wheel to unlock the pawl as has been the practice in the past, has resulted in some painful accidents to the operators including even the loss of fingers when the crank or pry bar has been accidentally released during the tension releasing process.

PRIOR ART

In my prior application, the following art was made of record:

65,386 to Hubbard	June 4, 1867
78,245 to Weiland	May 26, 1868
351,735 to Brill	November 2, 1886
416,996 to Cook	December 10, 1889
500,529 to Burns	June 27, 1893
2,899,841 to Melloy	August 18, 1959
3,988,007 to Freiburger Jr.	October 26, 1976
4,635,773 to Llewllin	January 13, 1987

While all of the above cited patents illustrate various one-way drive systems making use of a ratchet drive means, only Cook and Freiburger show means to tension a flexible or other means and lock the flexible element in its tensioned condition.

Hubbard and Weiland show one way ratchet drive means for use on agricultural equipment. Brill and

Burns show manually driven crank means operating through a ratchet drive for applying the brakes on railroad cars and Melloy shows a one way ratchet drive for a control knob on a household appliance. Not one of these prior art patents describes a locking means associated with the ratcheting device.

The patent to Cook discloses a means that forms a clutch in a device for applying the brakes on a railroad car or the like wherein a pawl or foot dog 18 is shown that coacts with a toothed ratchet 8 to enable a brakeman to pull a tension in a chain to apply the brakes on a railroad car. When the brakes have been set, the pawl or foot dog 18 engages the ratchet to hold the brakes set hard. In order to unlock the brakes, the brake-handle may be moved to a position to turn the ratchet forwardly "with his entire strength" (page 2, column 1, line 28) to give the ratchet some additional forward movement to enable the brakeman to move the foot-dog to release the ratchet.

The Freiburger Jr. patent discloses a device adapted for a sedentary use such as for holding down a mobile home. This construction makes use of a bolt rotatably mounted in a holder adapted to be anchored to the ground. The bolt is driven to wind up a strap to place a constant pull on the structure to which the strap is attached by connecting the strap supporting means to an anchoring device that is resiliently supported from a rod driven into the ground.

The Freiburger Jr. structure includes a series of coacting ratcheting teeth associated with a fixed means that supports the bolt. The teeth are resiliently urged into engagement by means of a spring that cooperates with the bolt as the bolt is rotated by a hand held wrench to wind up the strap to place it under tension. Once the holding means is placed under tension. This device is intended to be mounted permanently in one place and no means are shown for unloading the resilient tension pulled on the strap.

SUMMARY OF THE INVENTION

This device finds use particularly in the heavy duty transport field and includes a ratchet having an input element and an output or hold-back element arranged for relative rotation about a common axis of a take up shaft and in this disclosure the output element has a limited relative resilient longitudinal movement along the shaft relative to the input element. Each element has a circular array of teeth that engages a similar array of teeth on the other element. Each tooth has an axially-extending forward face and an inclined rearward face. The teeth in the input element face in one direction opposite to the direction of the teeth on the output element, so that rotation of the input element in one direction causes the rearward faces to act in a camming mode with relative axial movement of the output element to the input element, while rotation of the input element in the other direction causes the forward faces to engage in a locking mode.

In its preferred form, the tie-down is mounted along a side of a transport means. For this use the input element is integral with the shaft for winding a flexible hold-down means around its periphery and the relatively longitudinally movable output element is non-rotatably mounted relative to the input means. When the input element is driven to wind up the flexible strap or other holding means for engaging the object to be held on the transport, the teeth on the input and output

Explore Litigation Insights

Docket Alarm provides insights to develop a more informed litigation strategy and the peace of mind of knowing you're on top of things.

Real-Time Litigation Alerts



Keep your litigation team up-to-date with **real-time alerts** and advanced team management tools built for the enterprise, all while greatly reducing PACER spend.

Our comprehensive service means we can handle Federal, State, and Administrative courts across the country.

Advanced Docket Research



With over 230 million records, Docket Alarm's cloud-native docket research platform finds what other services can't. Coverage includes Federal, State, plus PTAB, TTAB, ITC and NLRB decisions, all in one place.

Identify arguments that have been successful in the past with full text, pinpoint searching. Link to case law cited within any court document via Fastcase.

Analytics At Your Fingertips



Learn what happened the last time a particular judge, opposing counsel or company faced cases similar to yours.

Advanced out-of-the-box PTAB and TTAB analytics are always at your fingertips.

API

Docket Alarm offers a powerful API (application programming interface) to developers that want to integrate case filings into their apps.

LAW FIRMS

Build custom dashboards for your attorneys and clients with live data direct from the court.

Automate many repetitive legal tasks like conflict checks, document management, and marketing.

FINANCIAL INSTITUTIONS

Litigation and bankruptcy checks for companies and debtors.

E-DISCOVERY AND LEGAL VENDORS

Sync your system to PACER to automate legal marketing.