

**United States Patent** [19]

**Rupp et al.**

[11] **Patent Number:** 5,653,691

[45] **Date of Patent:** Aug. 5, 1997

[54] **THICKENED INNER LUMEN FOR UNIFORM STENT EXPANSION AND METHOD OF MAKING**

5,403,341 4/1995 Solar ..... 606/198  
5,409,495 4/1995 Osborn ..... 606/108

**FOREIGN PATENT DOCUMENTS**

0553960 4/1993 European Pat. Off. .... A61F 2/06

*Primary Examiner*—Corrine M. McDermott  
*Assistant Examiner*—Cris L. Rodriguez  
*Attorney, Agent, or Firm*—Dianne M. F. Plunkett; Harold R. Patton

[76] **Inventors:** **Garry Eugene Rupp**, 10777-B Andrea Ter., Santee, Calif. 92071; **Randell L. Werneth**, 11315 Affinity Ct., #145, San Diego, Calif. 92131; **Perfecta P. Tilos**, 8277 Calle Pino, San Diego, Calif. 92126

[57] **ABSTRACT**

An intravascular catheter system for implanting a radially expandable stent within a body vessel including a catheter comprising an inner lumen tube, an inflation lumen tube, an inflatable balloon and at least one free standing built-up layer affixed to the outer diameter of the inner lumen tube, the built-up layer being internal to the balloon. A stent is mounted coaxially upon the balloon, the built-up layer extends coaxially within the stent but does not extend beyond the proximal and distal ends of the stent. The built-up layer is sufficiently thick as to cause the balloon to expand evenly and the stent to deploy uniformly. The method of manufacturing the built-up layer includes forming the layer from shrink wrap tubing or alternatively forming the layer from molded ultraviolet light curing adhesive.

[21] Appl. No.: 637,959

[22] Filed: Apr. 25, 1996

[51] Int. Cl.<sup>6</sup> ..... A61M 29/00

[52] U.S. Cl. .... 604/96; 606/194

[58] **Field of Search** ..... 604/96, 103, 171, 604/280, 282, 273, 104; 128/658; 606/192, 194, 195, 108

[56] **References Cited**

**U.S. PATENT DOCUMENTS**

4,886,062 12/1989 Wiktor ..... 128/343  
4,981,478 1/1991 Evard et al. .... 604/282  
5,133,732 7/1992 Wiktor ..... 606/195  
5,256,143 10/1993 Miller et al. .... 604/96

**17 Claims, 5 Drawing Sheets**

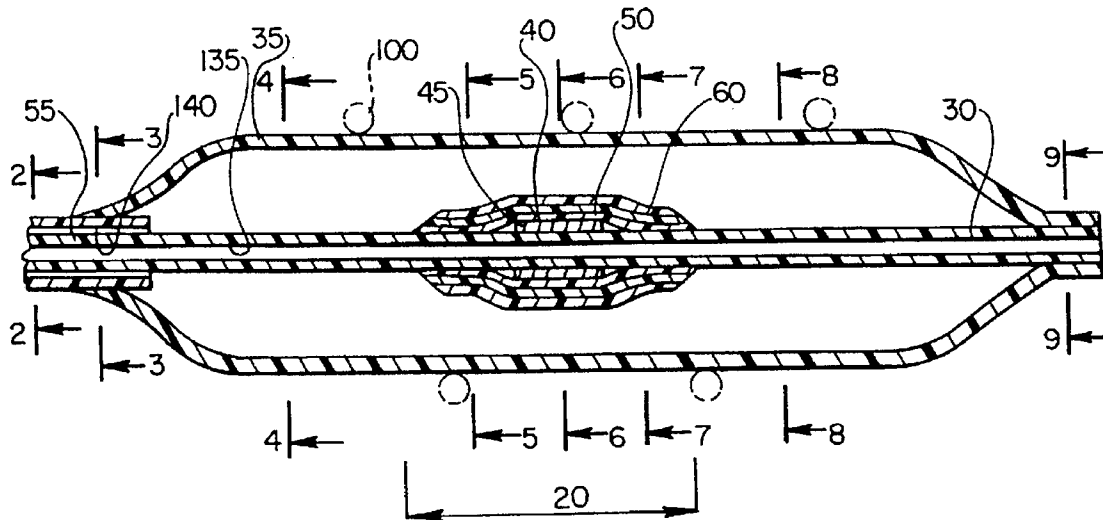

*Fig. 1*

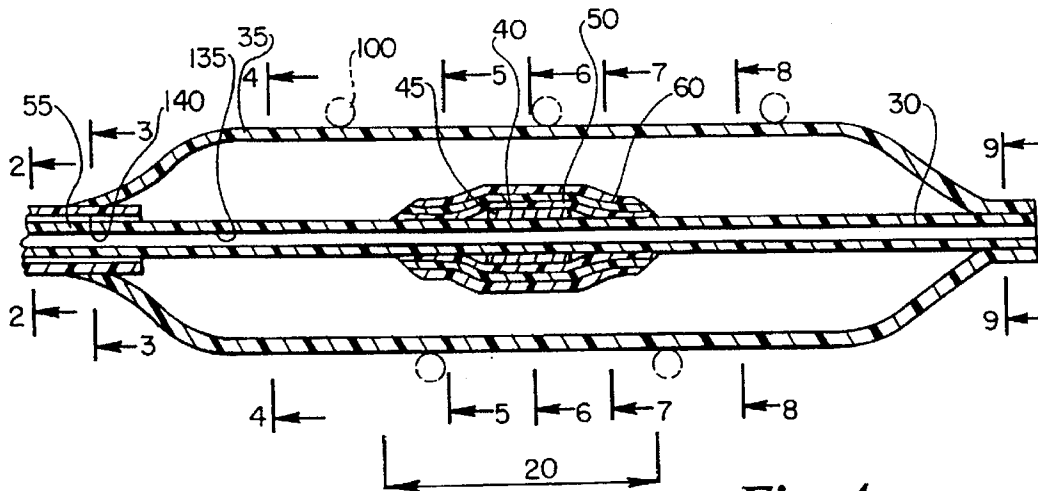

*Fig. 2*

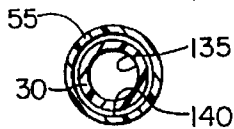

*Fig. 3*

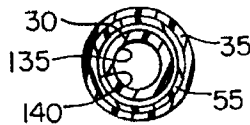

*Fig. 4*

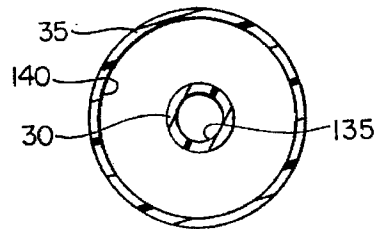

*Fig. 5*

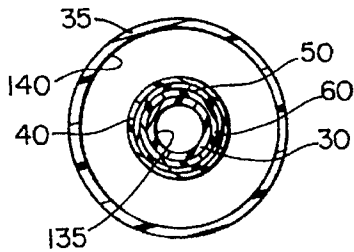

*Fig. 6*

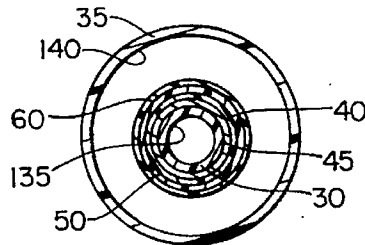

*Fig. 7*

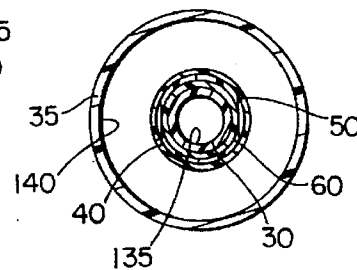

*Fig. 8*

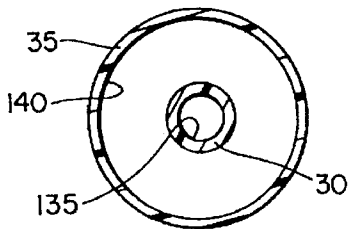

*Fig. 9*

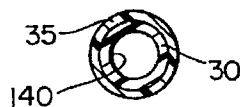

**Fig. 10**

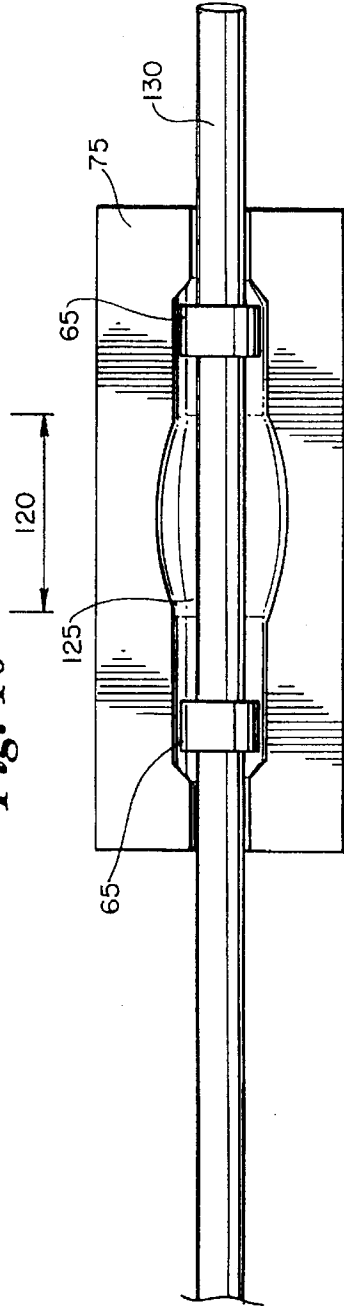

**Fig. 11**

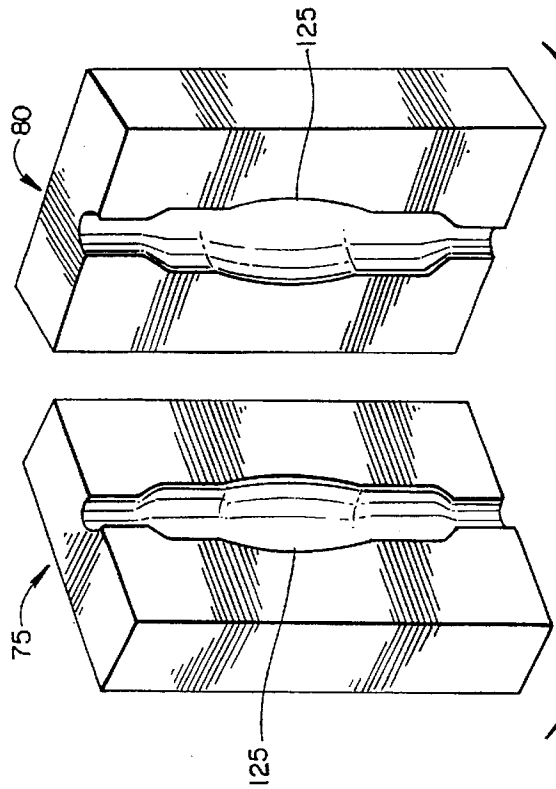

*Fig. 12*

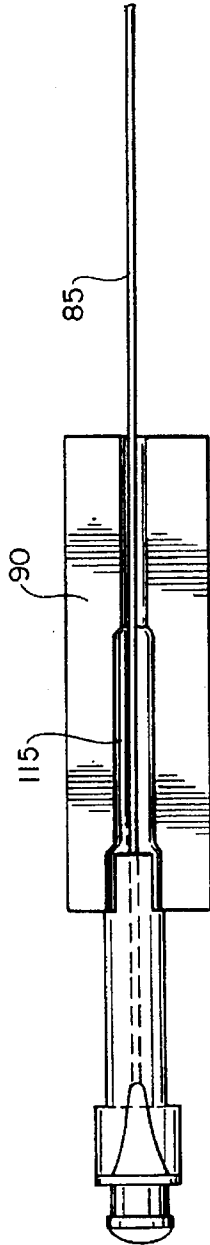

*Fig. 13*

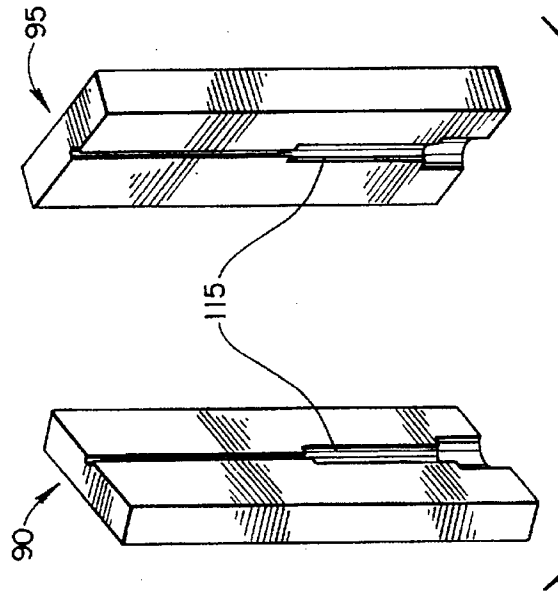

Fig. 14

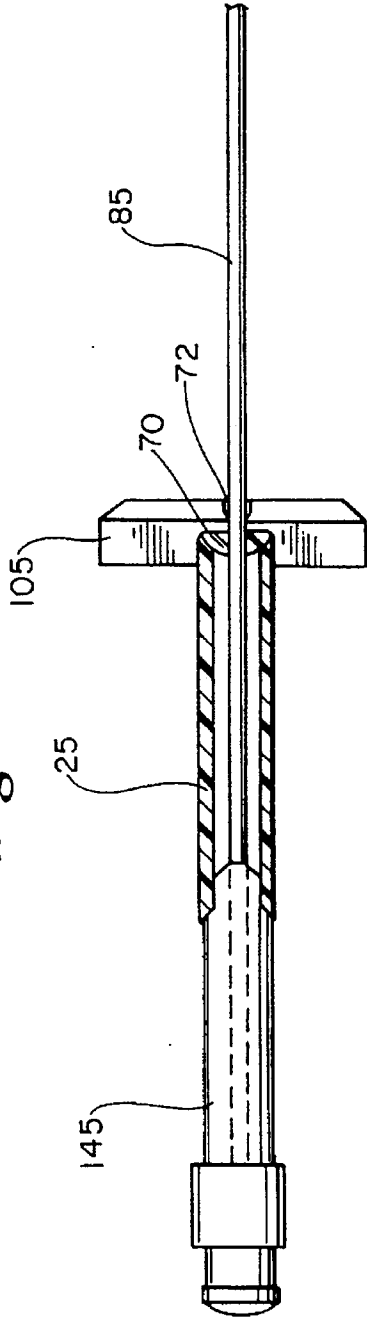
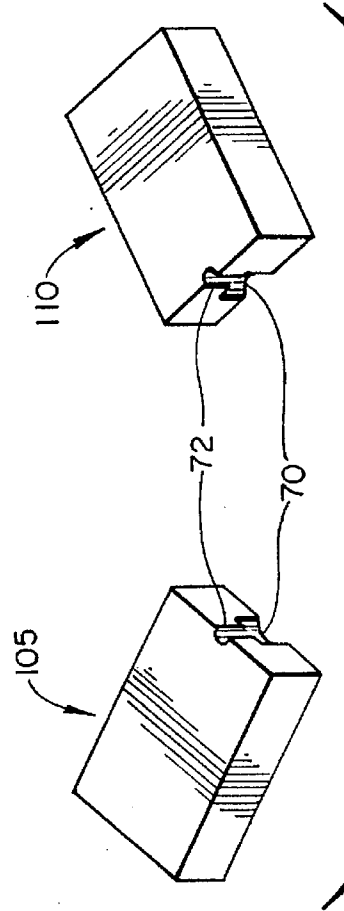

Fig. 15



# Explore Litigation Insights

Docket Alarm provides insights to develop a more informed litigation strategy and the peace of mind of knowing you're on top of things.

## Real-Time Litigation Alerts



Keep your litigation team up-to-date with **real-time alerts** and advanced team management tools built for the enterprise, all while greatly reducing PACER spend.

Our comprehensive service means we can handle Federal, State, and Administrative courts across the country.

## Advanced Docket Research



With over 230 million records, Docket Alarm's cloud-native docket research platform finds what other services can't. Coverage includes Federal, State, plus PTAB, TTAB, ITC and NLRB decisions, all in one place.

Identify arguments that have been successful in the past with full text, pinpoint searching. Link to case law cited within any court document via Fastcase.

## Analytics At Your Fingertips



Learn what happened the last time a particular judge, opposing counsel or company faced cases similar to yours.

Advanced out-of-the-box PTAB and TTAB analytics are always at your fingertips.

## API

Docket Alarm offers a powerful API (application programming interface) to developers that want to integrate case filings into their apps.

## LAW FIRMS

Build custom dashboards for your attorneys and clients with live data direct from the court.

Automate many repetitive legal tasks like conflict checks, document management, and marketing.

## FINANCIAL INSTITUTIONS

Litigation and bankruptcy checks for companies and debtors.

## E-DISCOVERY AND LEGAL VENDORS

Sync your system to PACER to automate legal marketing.