



US005197005A

United States Patent [19]

[11] Patent Number: 5,197,005

Shwartz et al.

[45] Date of Patent: Mar. 23, 1993

- [54] DATABASE RETRIEVAL SYSTEM HAVING A NATURAL LANGUAGE INTERFACE
- [75] Inventors: Steven Shwartz, Orange; Claudio Fratarcangeli, Trumbull; Richard E. Cullingford, Monroe; Gregory S. Aimi, North Haven; Donald P. Strasburger, Stratford, all of Conn.
- [73] Assignee: Intelligent Business Systems, Milford, Conn.
- [21] Appl. No.: 345,966
- [22] Filed: May 1, 1989
- [51] Int. Cl.<sup>5</sup> ..... G06F 15/40
- [52] U.S. Cl. .... 364/419; 395/600; 364/DIG. 1; 364/274; 364/274.2; 364/274.3; 364/274.8
- [58] Field of Search ..... 364/513, 419, 200 MS File, 364/900 MS File; 395/600, 12
- [56] References Cited

U.S. PATENT DOCUMENTS

4,736,296	4/1988	Katayama et al.	364/419
4,811,207	3/1989	Hikita et al.	364/900
4,839,853	6/1989	Deerwester et al.	364/900
4,914,590	4/1990	Loatman et al.	364/419
4,930,071	5/1990	Tou et al.	314/300
4,931,935	6/1990	Ohira et al.	364/419
4,943,933	7/1990	Miyamoto et al.	364/513
4,974,191	11/1990	Amirghodsi et al.	395/700
4,994,967	2/1991	Asakawa	364/419

FOREIGN PATENT DOCUMENTS

63-219034 9/1988 Japan

OTHER PUBLICATIONS

- Winston, "Natural Language Understanding", *Artificial Intelligence*, CH. 9, pp. 291-334.
- Rich, "Natural Language Interfaces", *IEEE Computer*, Sep. 1984, pp. 39-47.
- Kao et al., Providing Quality Responses with Natural Language Interfaces: the Null Value Problem, *IEEE Trans. Software Eng.*, vol. 14, No. 7, 1988.
- "Natural Language Interfaces: Benefits, Requirements, State of the Art and Applications", by John L. Manferdelli, *A. I. East*, Oct. 1987.

"Inside Computer Understanding", Schank and Riesbeck, Erlbaum Press, 1981, Chapter 14.

"The LIFER Manual: A Guide to Building Practical Natural Language Interfaces", by Gary G. Hendrix, SRI International, Technical Note 138, Feb. 1977.

"Human Engineering for Applied Natural Language Processing", by Gary G. Hendrix, SRI International, Technical Note 139, Feb. '77.

"Applied Natural Language Processing", Shwartz, Steven C., Petrocelli Books, Princeton, N.J., 1987.

Primary Examiner—Michael R. Fleming

Assistant Examiner—Debra A. Chun

Attorney, Agent, or Firm—Barry R. Lipsitz

[57] ABSTRACT

A database retrieval system having a natural language interface is provided. A database developer creates a knowledge base containing a structural description and semantic description of an application database from which data is to be retrieved. A database independent, canonical internal meaning representation of a natural language query is produced. An expert system accesses structural and semantic description information in the knowledge base and, in accordance with predefined rules, identifies database elements from said information that are necessary to satisfy the query represented by the internal meaning representation. A database query is generated among the database elements, enabling the retrieval and aggregation of data from the database to satisfy the natural language query. A debugging facility derives an external meaning representation from the internal meaning representation. The external meaning representation is database-independent, canonical, and easily understandable to the database developer. The external meaning representation enables the database developer to comprehend the internal meaning representation and verify that a natural language query is properly interpreted by the system to effect the accurate retrieval and aggregation of data from the database. The external meaning representation comprises entities and constraints relating to the entities, without reference to factual or linguistic relationships between entities that would prevent the external meaning representation from being easily understood.

41 Claims, 11 Drawing Sheets

Microfiche Appendix Included (11,603 Microfiche, 47 Pages)

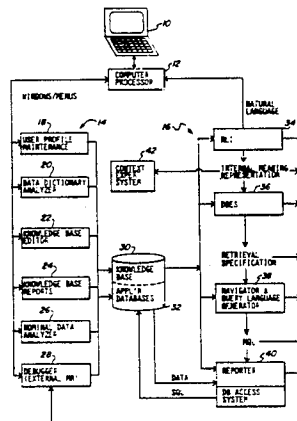

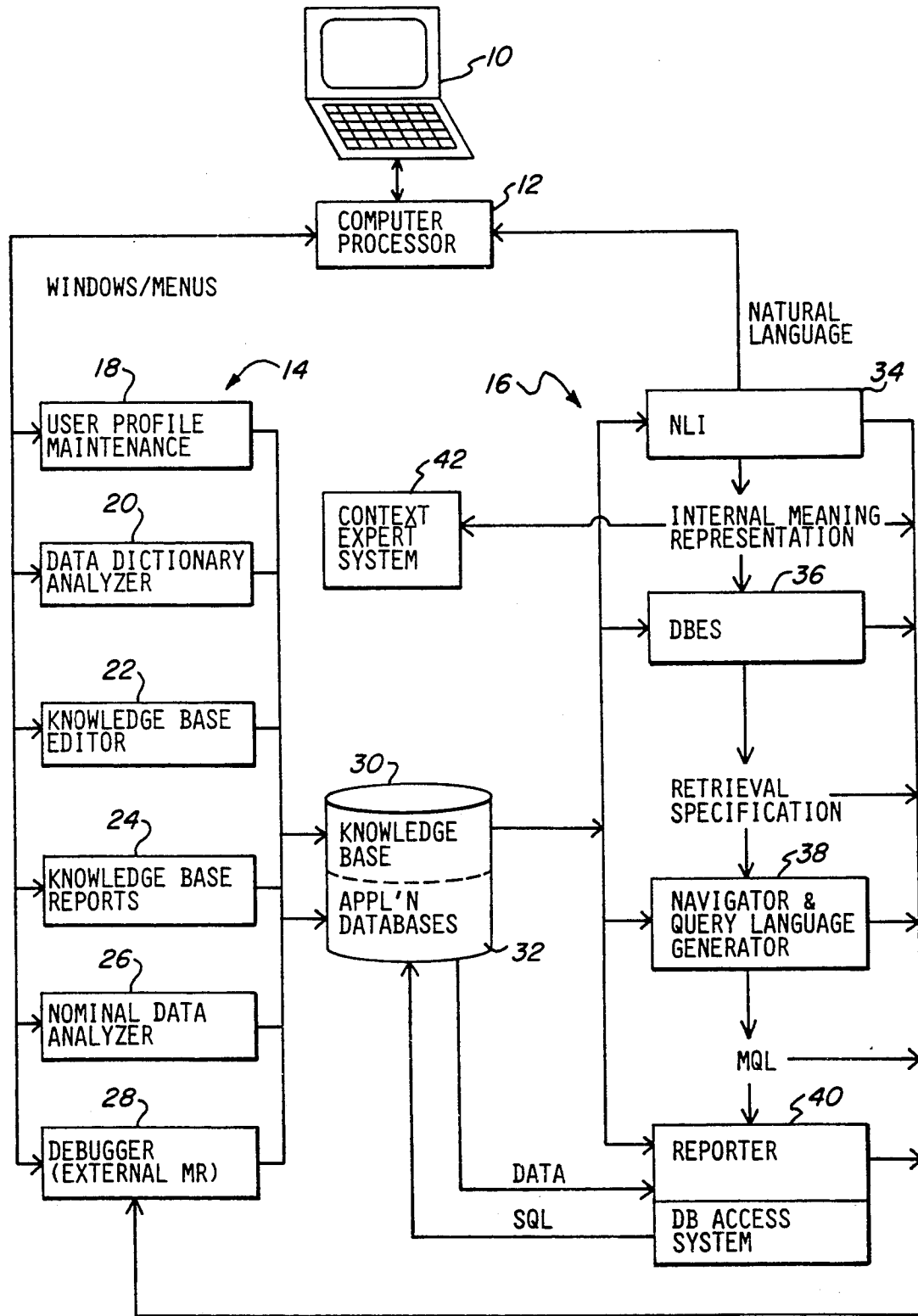

FIG. 1

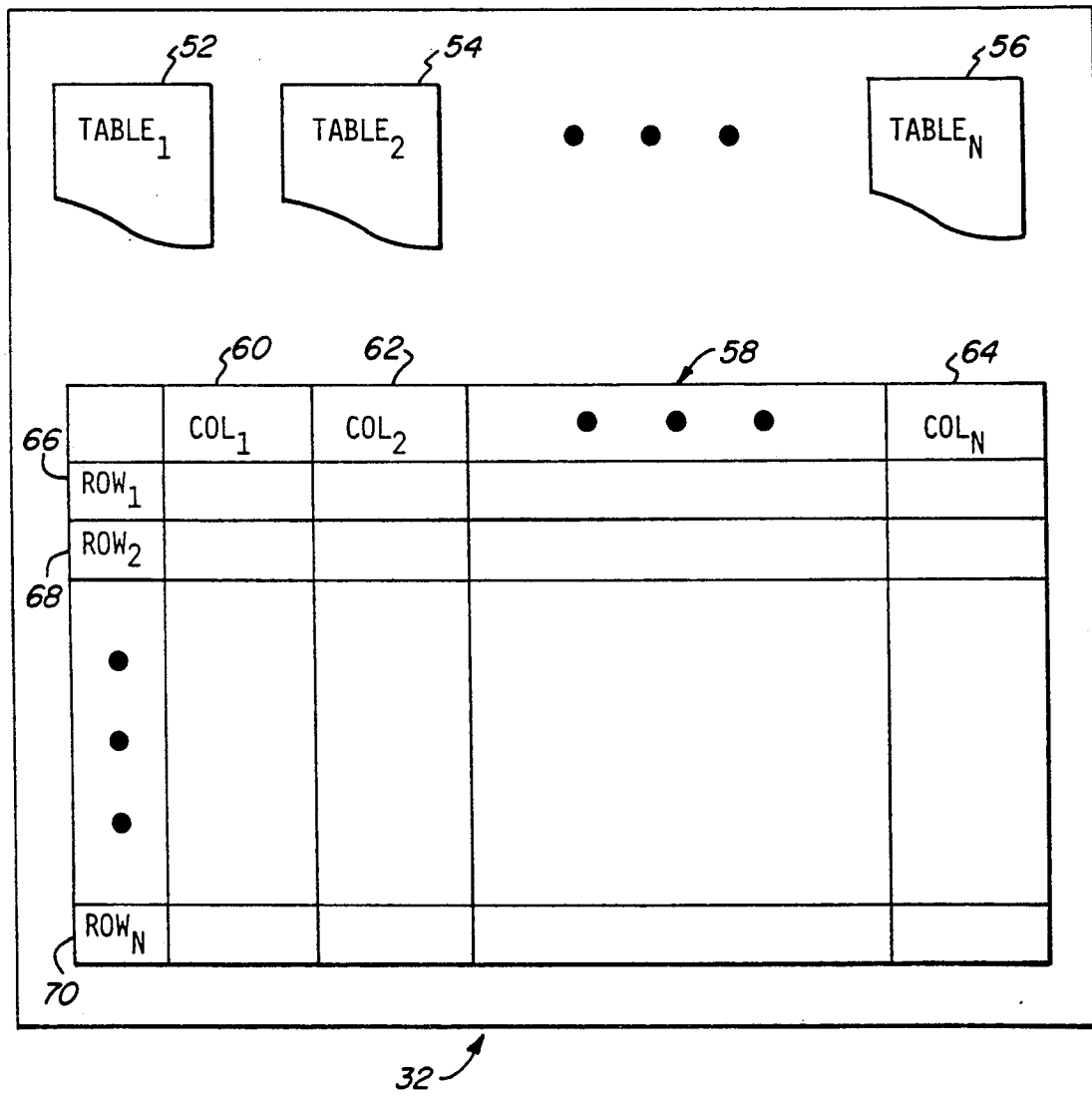

FIG. 2

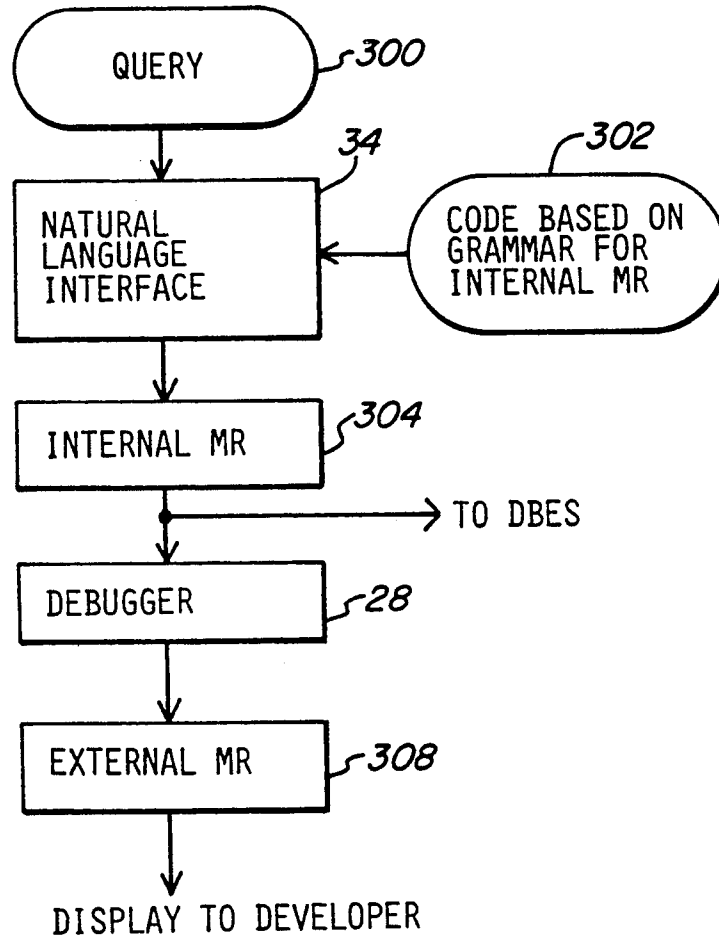

FIG. 3

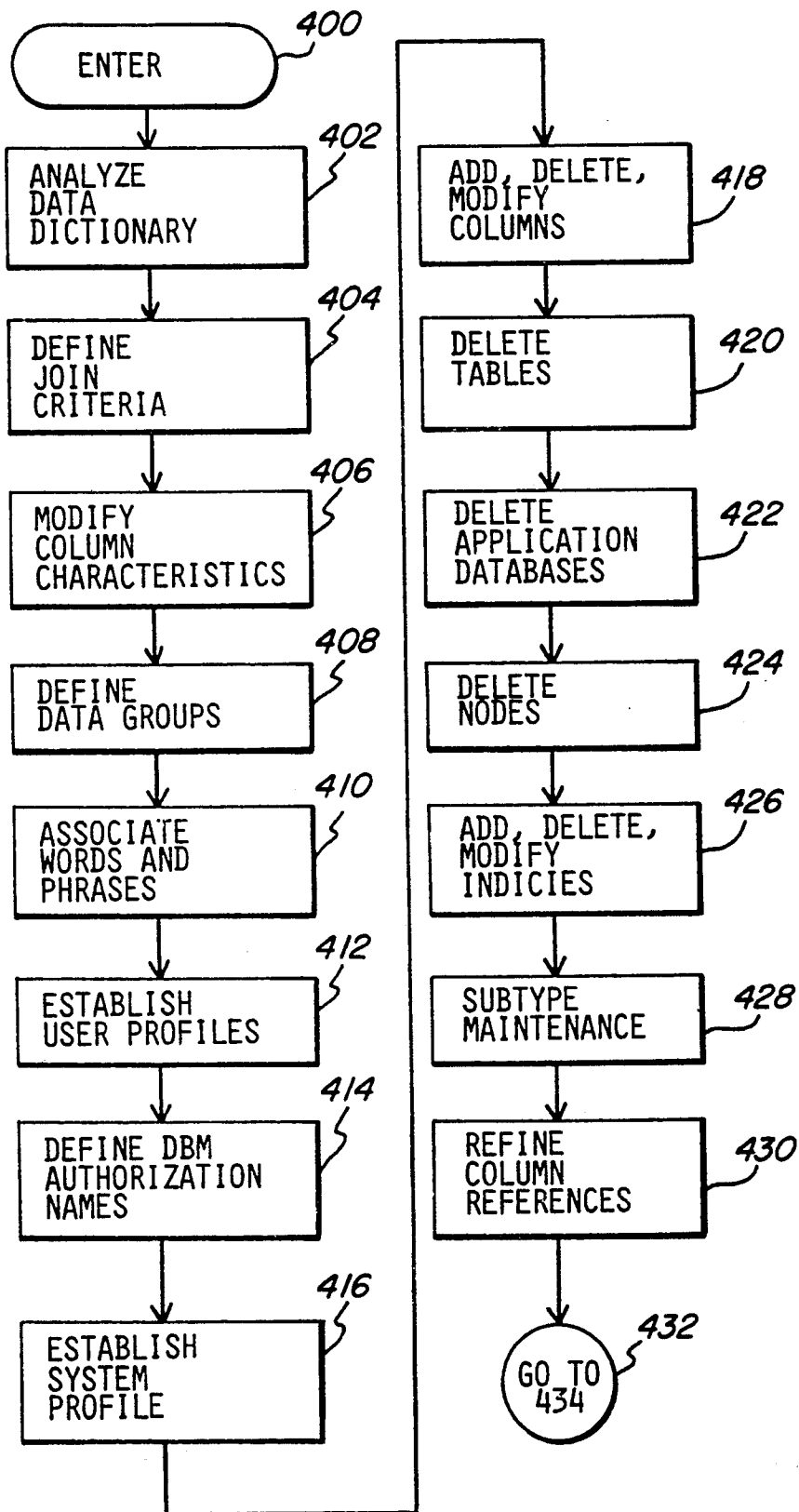

FIG. 1a

# Explore Litigation Insights

Docket Alarm provides insights to develop a more informed litigation strategy and the peace of mind of knowing you're on top of things.

## Real-Time Litigation Alerts



Keep your litigation team up-to-date with **real-time alerts** and advanced team management tools built for the enterprise, all while greatly reducing PACER spend.

Our comprehensive service means we can handle Federal, State, and Administrative courts across the country.

## Advanced Docket Research



With over 230 million records, Docket Alarm's cloud-native docket research platform finds what other services can't. Coverage includes Federal, State, plus PTAB, TTAB, ITC and NLRB decisions, all in one place.

Identify arguments that have been successful in the past with full text, pinpoint searching. Link to case law cited within any court document via Fastcase.

## Analytics At Your Fingertips



Learn what happened the last time a particular judge, opposing counsel or company faced cases similar to yours.

Advanced out-of-the-box PTAB and TTAB analytics are always at your fingertips.

## API

Docket Alarm offers a powerful API (application programming interface) to developers that want to integrate case filings into their apps.

## LAW FIRMS

Build custom dashboards for your attorneys and clients with live data direct from the court.

Automate many repetitive legal tasks like conflict checks, document management, and marketing.

## FINANCIAL INSTITUTIONS

Litigation and bankruptcy checks for companies and debtors.

## E-DISCOVERY AND LEGAL VENDORS

Sync your system to PACER to automate legal marketing.