

UNITED STATES PATENT AND TRADEMARK OFFICE

---

BEFORE THE PATENT TRIAL AND APPEAL BOARD

---

ORTHOPEDIATRICS CORP.,  
Petitioner,

v.

K2M, INC.,  
Patent Owner.

---

Case IPR2018-00521  
Patent 9,532,816 B2

---

Before LYNNE H. BROWNE, MICHAEL L. WOODS, and  
ROBERT L. KINDER, *Administrative Patent Judges*.

BROWNE, *Administrative Patent Judge*.

FINAL WRITTEN DECISION  
*35 U.S.C. § 318(a) and 37 C.F.R. § 42.73*

## I. INTRODUCTION

Orthopediatrics Corp. (“Petitioner”), on January 8, 2018, filed a Petition requesting *inter partes* review of claims 16, 18, 19, 21, and 22 of U.S. Patent No. 9,532,816 B2 (“the ’816 patent”). (Paper 1, “Pet.”). We issued a Decision to Institute an *inter partes* review (Paper 8, “DI”) of all challenged claims (16, 18, 19, 21, and 22) under all grounds, namely Grounds 1–8 discussed below.

After institution of trial, K2M, Inc. (“Patent Owner”) filed a Patent Owner Response (Paper 20, “PO Resp.”), to which Petitioner replied (Paper 26, “Pet. Reply”). Patent Owner also filed a Sur-Reply (Paper 31, “PO Sur-Reply”).

Oral argument was concurrently conducted on February 21, 2019, for this and related proceeding IPR2018-00429, and the transcript of the hearing has been entered as Paper 37.

We have jurisdiction under 35 U.S.C. § 318(a). After considering the evidence and arguments of both parties, and for the reasons set forth below, we determine that Petitioner has not met its burden of showing, by a preponderance of the evidence, that any of claims 16, 18, 19, 21, and 22 are unpatentable.

## II. BACKGROUND

### A. *Related Proceedings*

Petitioner is a defendant in a lawsuit involving the ’816 patent. Pet. 1 (referencing *K2M, Inc. v. OrthoPediatrics Corp. & OrthoPediatrics US Distribution Corp.*, Case No. 1:17-cv-00061-GMS (D. Del.)).

On the same day that the Petition in the instant proceeding was filed, Petitioner filed another petition requesting *inter partes* review challenging

IPR2018-00521  
Patent 9,532,816 B2

claims 16, 18, 19, 21, and 22 of the '816 patent. IPR2018-00429. The final decision in that proceeding is being issued concurrently with this decision. Subsequently, Petitioner filed three Petitions challenging claims 1, 3, 5, 6, 8–10, 12, and 15–19 of U.S. Patent No. 9,655,664 B2 which is a divisional of the '816 patent. IPR2018-01546, 1547, 1548.

*B. The '816 Patent*

The '816 patent is directed to “devices for stabilizing and fixing the bones and joints of the body. Particularly, the present invention relates to a manually operated device capable of reducing a rod into position in a rod receiving notch in the head of a bone screw with a controlled, measured action.” Ex. 1101, 1:14–19. The device described in the '816 patent achieves this objective by grasping “the head of a bone screw and reduc[ing] a rod into the rod receiving recess of the bone screw using a single manual control that can be activated in a controlled and measured manner.” *Id.* at 2:23–27.

Figure 4 reproduced below illustrates the device:

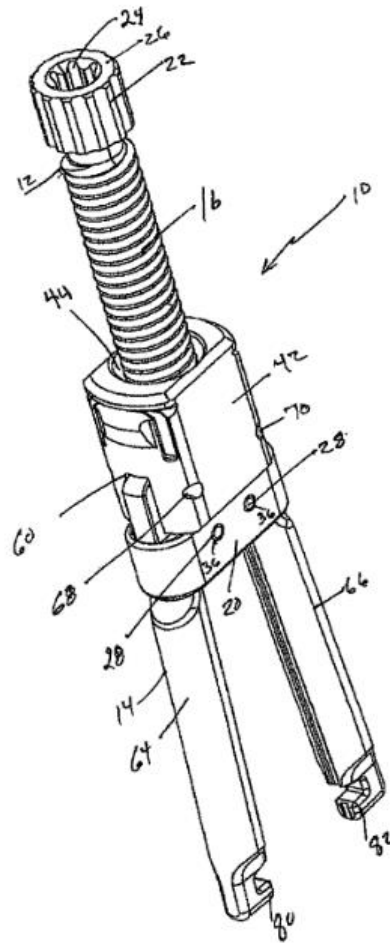

FIG 4

Figure 4 is an isometric view of the rod reducing device with the screw jack mechanism fully retracted and the two elongated grasping members in an open configuration. Ex. 1101, 3:27–30.

The '816 patent explains:

The device . . . is a rod [34] reduction device capable of reducing a rod into position in a rod receiving notch in the head of a bone screw with a controlled, measured action. The device is an elongated rod reduction device 10 that includes a screw jack mechanism 12 moveably engaged with an elongated grasping fork assembly 14. The screw jack mechanism 12 includes an

elongated threaded screw shaft 16 that terminates at its most proximal end with a controlling member 18 and terminates at its most distal end with a rod contact member 20.

*Id.* at 3:63–4:5.

### C. *Illustrative Claim*

Petitioner challenges claims 16, 18, 19, 21, and 22 of the '816 patent.

Claim 16, reproduced below, is the challenged independent claim.

16. A rod reducing device comprising:  
a housing defining a longitudinal axis, the housing including first and second grasping members configured to grasp a portion of a bone anchor therebetween, the first and second grasping members defining a plane;  
a rotatable member extending through the housing along the longitudinal axis; and  
a rod contact member positioned at a distal end of the rotatable member, the rod contact member translatable along the longitudinal axis in response to rotation of the rotatable member about the longitudinal axis, wherein the rod contact member and the rotatable member are translatable within the plane defined by the first and second grasping members.

Ex. 1101, 10:22–35.

### D. *References Relied Upon*

The Petitioner relies in relevant part on the following references

(*See* Pet. 4):

Name	Reference	Ex. No.
Whipple	US 2006/0293692 A1, published Dec. 28, 2006	1102
Runco	US 2006/0079909 A1, published Apr. 13, 2006	1103
Varieur	US 2005/0149053 A1, published July 7, 2005	1104
Jackson	US 2005/0192570 A1, published Sept. 1, 2005	1105
Trudeau	US 2006/0089651 A1, Published Apr. 27, 2006	1106

# Explore Litigation Insights

Docket Alarm provides insights to develop a more informed litigation strategy and the peace of mind of knowing you're on top of things.

## Real-Time Litigation Alerts



Keep your litigation team up-to-date with **real-time alerts** and advanced team management tools built for the enterprise, all while greatly reducing PACER spend.

Our comprehensive service means we can handle Federal, State, and Administrative courts across the country.

## Advanced Docket Research



With over 230 million records, Docket Alarm's cloud-native docket research platform finds what other services can't. Coverage includes Federal, State, plus PTAB, TTAB, ITC and NLRB decisions, all in one place.

Identify arguments that have been successful in the past with full text, pinpoint searching. Link to case law cited within any court document via Fastcase.

## Analytics At Your Fingertips



Learn what happened the last time a particular judge, opposing counsel or company faced cases similar to yours.

Advanced out-of-the-box PTAB and TTAB analytics are always at your fingertips.

## API

Docket Alarm offers a powerful API (application programming interface) to developers that want to integrate case filings into their apps.

## LAW FIRMS

Build custom dashboards for your attorneys and clients with live data direct from the court.

Automate many repetitive legal tasks like conflict checks, document management, and marketing.

## FINANCIAL INSTITUTIONS

Litigation and bankruptcy checks for companies and debtors.

## E-DISCOVERY AND LEGAL VENDORS

Sync your system to PACER to automate legal marketing.