



US007420756B2

(12) **United States Patent**
Lynam

(10) **Patent No.:** **US 7,420,756 B2**
(45) **Date of Patent:** **Sep. 2, 2008**

- (54) **MIRROR REFLECTIVE ELEMENT**
- (75) Inventor: **Niall R. Lynam**, Holland, MI (US)
- (73) Assignee: **Donnelly Corporation**, Holland, MI (US)
- (*) Notice: Subject to any disclaimer, the term of this patent is extended or adjusted under 35 U.S.C. 154(b) by 40 days.
- (21) Appl. No.: **10/709,434**
- (22) Filed: **May 5, 2004**

(65) **Prior Publication Data**
US 2004/0264011 A1 Dec. 30, 2004

Related U.S. Application Data
(60) Provisional application No. 60/471,872, filed on May 20, 2003.

(51) **Int. Cl.**
G02B 5/08 (2006.01)
G02B 5/26 (2006.01)
G02B 7/182 (2006.01)

(52) **U.S. Cl.** **359/884**; 359/883
(58) **Field of Classification Search** 359/866, 359/868, 883, 514, 884
See application file for complete search history.

(56) **References Cited**
U.S. PATENT DOCUMENTS
3,759,647 A 9/1973 Schrenk et al. 425/131
3,773,882 A 11/1973 Schrenk 264/171

3,884,606 A	5/1975	Schrenk	425/133.5
4,193,668 A	3/1980	Skinner	350/281
4,385,804 A	5/1983	Tamura et al.	350/310
4,666,264 A	5/1987	Yamabe	350/641
4,737,188 A	4/1988	Bahls	106/1.23
4,944,581 A	7/1990	Ichikawa	350/641
5,085,907 A	2/1992	Smith	428/40
5,262,894 A *	11/1993	Wheatley et al.	359/586
5,361,172 A	11/1994	Schissel et al.	359/883
5,483,386 A	1/1996	Carson	359/883
6,030,084 A *	2/2000	Schmidt	359/868
6,409,354 B1	6/2002	Richard	359/883
6,522,451 B1	2/2003	Lynam	359/265
6,709,119 B2 *	3/2004	Gillich et al.	359/883

* cited by examiner
Primary Examiner—Alessandro Amari
(74) *Attorney, Agent, or Firm*—Van Dyke, Gardner, Linn & Burkhart LLP

(57) **ABSTRACT**
A reflective element for a mirror assembly for a vehicle includes a substrate and a functional or anti-abrasion film applied to an exterior surface of the substrate. The substrate comprises a polymeric resin material, such as a transparent optical polymeric resin material. The functional or anti-abrasion film may comprise a glass material and may have a thickness of less than approximately 0.8 mm. The anti-abrasion film is flexible to conform to the exterior surface of the substrate. The flexible film may be unrolled from a reel or roll and applied to the exterior surface of an elongated strip or sheet of substrate material. The substrate, including the glass film or layer, may then be cut or otherwise formed from the elongated strip or sheet of molded or extruded or cast substrate material.

11 Claims, 3 Drawing Sheets

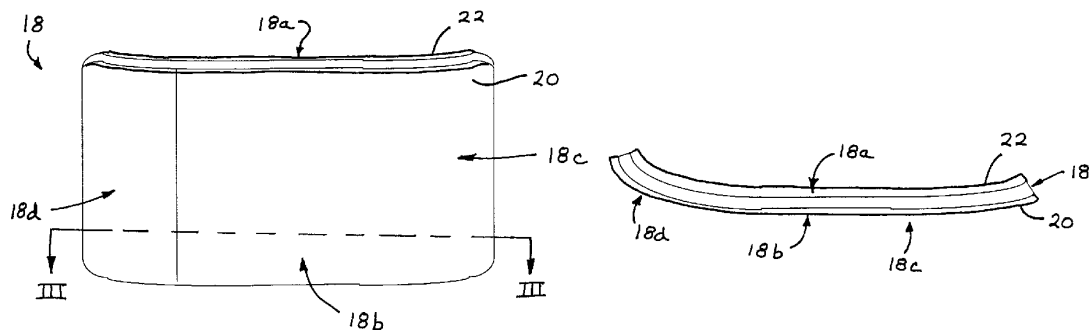

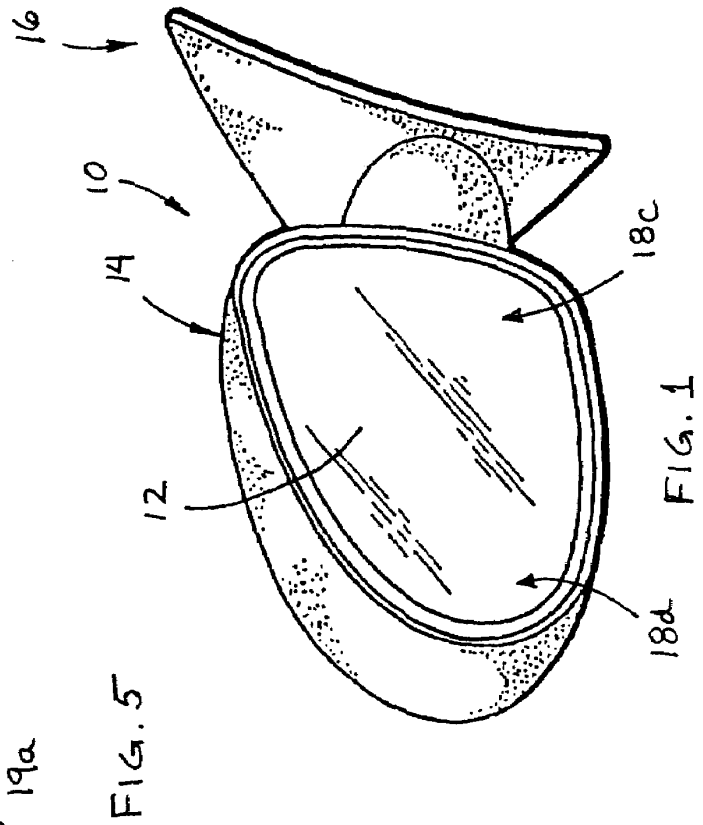
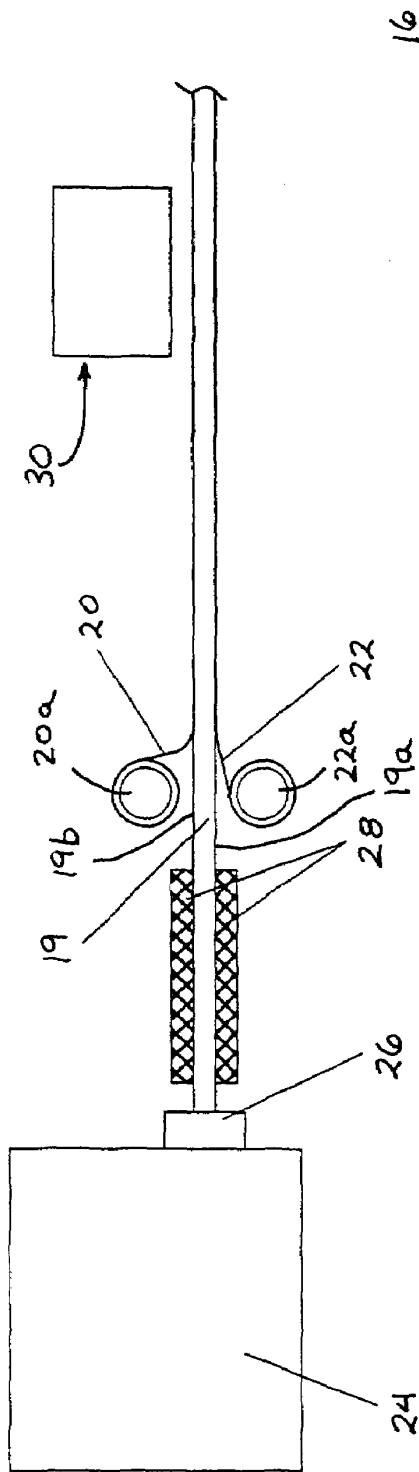

FIG. 5

FIG. 1

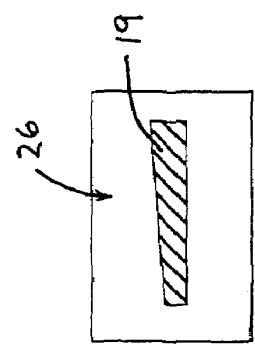

FIG. 5A

FIG. 3

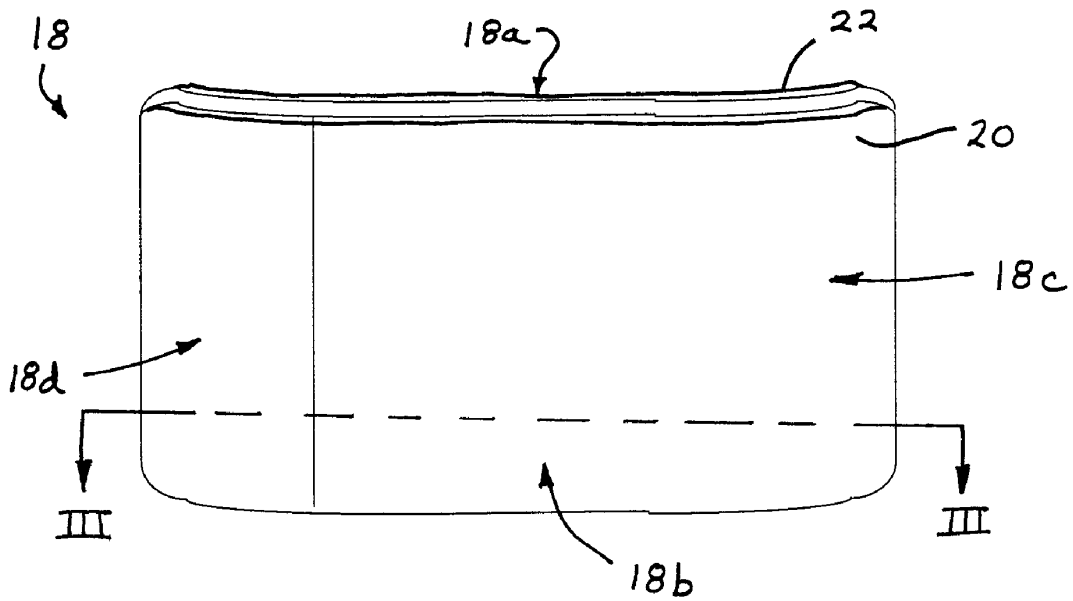
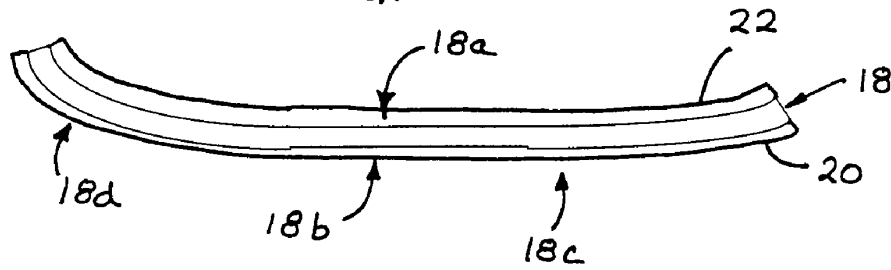
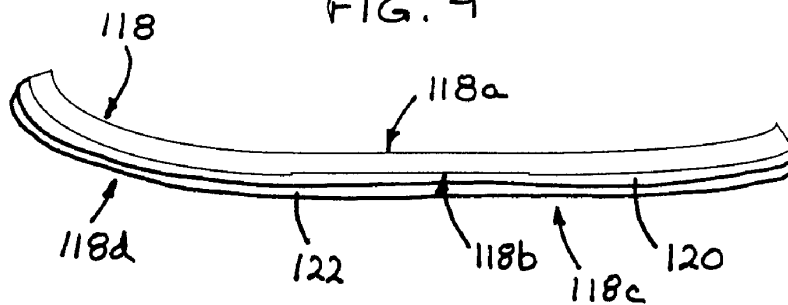
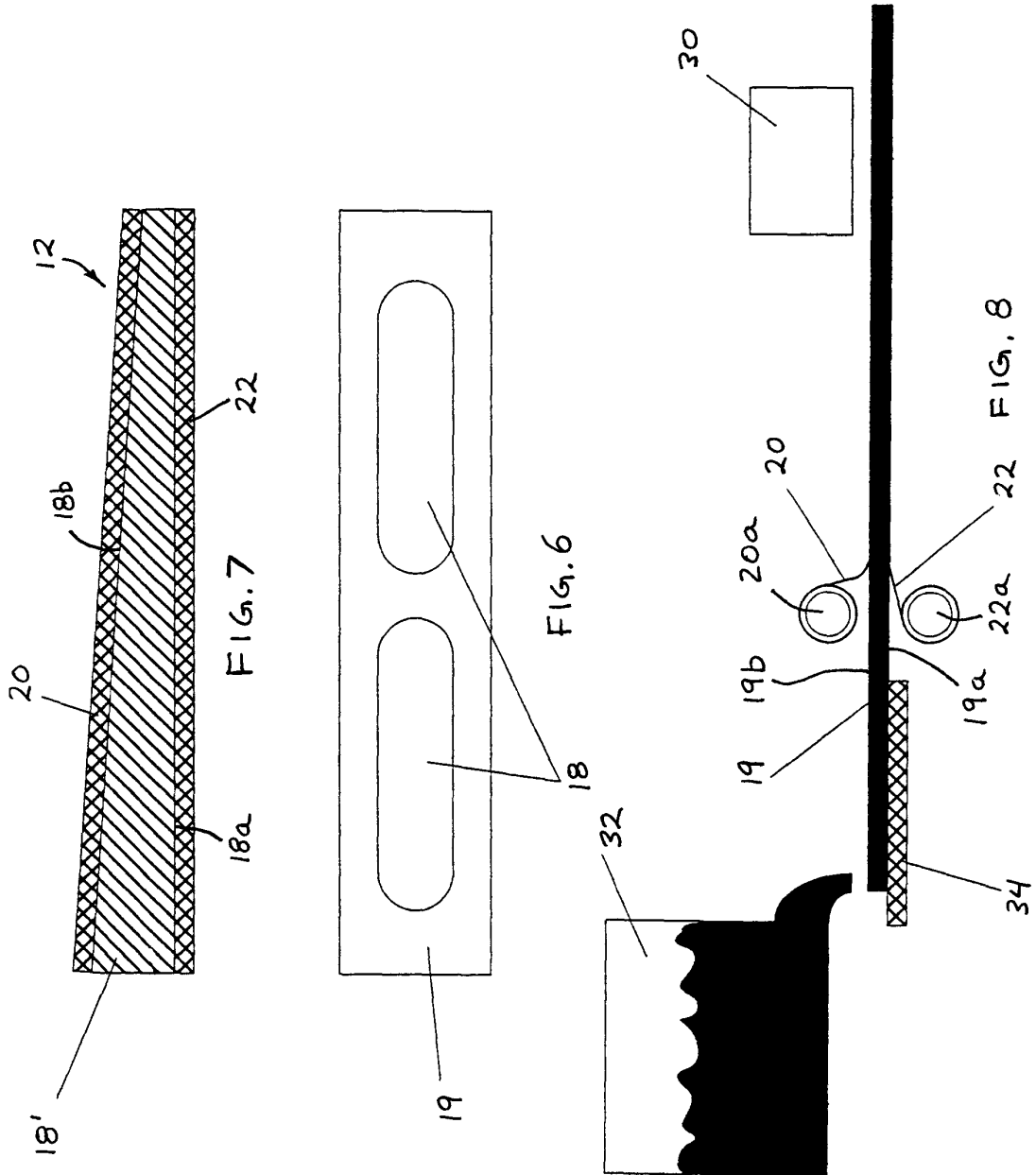

FIG. 2

FIG. 4





1

MIRROR REFLECTIVE ELEMENT**CROSS REFERENCE TO RELATED APPLICATIONS**

The present application claims the benefit of U.S. provisional application Ser. No. 60/471,872, filed May 20, 2003, which is hereby incorporated herein by reference in its entirety.

FIELD OF THE INVENTION

The present invention relates generally to rearview mirror elements for a rearview mirror assembly of a vehicle and, more particularly, to exterior rearview mirror elements comprising multi-radius reflective elements.

BACKGROUND OF THE INVENTION

Typically, mirror reflective elements are formed of glass and have a reflective coating deposited thereon, such as via vacuum deposition or wet chemical silvering or the like, such as on a silver line, such as described in U.S. Pat. No. 4,737,188, which is hereby incorporated herein by reference. Polymeric reflective elements are also known, such as are described in U.S. Pat. Nos. 6,601,960; 6,409,354; 4,944,581; 4,385,804; 4,193,668; 4,666,264; and 5,483,386, which are hereby incorporated herein by reference. For such polymeric mirror reflective elements, the need exists for a hard coat or surface on the first or outer or exterior surface of the element which is contacted by the exterior elements, such as rain, road debris, or the like, or contacted, for example, by a person scraping ice or wiping snow or condensation off the mirror element outer surface, such as during winter. A variety of hard coats have been proposed in the art, typically applied by dip coating or vacuum deposition techniques. However, a need exists for an automotive mirror reflective element which has the properties of plastic (i.e., a specific gravity roughly half that of glass), and which has a glass-like exterior surface.

Also, exterior rearview mirror reflective elements may be aspheric or multi-radius, and may typically have a less curved or substantially flat (around 2000 mm radius or thereabouts) inboard portion or surface at the inboard side of the reflective element (i.e., closer to the side body of the vehicle when the mirror assembly is mounted to the vehicle), and a more curved multi-radius portion or surface at the outboard side of the reflective element (i.e., further from the side body of the vehicle when the mirror assembly is mounted to the vehicle), in order to provide an extended field of view. It is typically desirable to have the reflective elements or substrates of such exterior mirror elements to be formed of a glass material because glass material typically provides an enhanced scratch resistance over conventional optical resins and the like.

Therefore, there is a need in the art for a mirror reflective element that overcomes the shortcomings of the prior art elements and substrates.

SUMMARY OF INVENTION

The present invention provides a molded wide angle or multi-radius substrate for a reflective element. The molded substrate comprises a polymeric optical resin transparent material and has a curved exterior surface, which may have a less curved/flatter or substantially flat inboard portion or surface and a more curved outboard portion or surface. The molded substrate may have an anti-abrasion film or layer, such as an ultrathin glass film, applied over the exterior sur-

2

face or first surface to provide substantial protection against scratches occurring to the molded substrate. The inner surface or second surface of the reflective element substrate may have a reflective coating or layer, such as a polymeric reflective film, laminated or adhered or otherwise applied thereto.

According to an aspect of the present invention, a wide angle reflective element for a mirror assembly for a vehicle includes a wide angle substrate having an exterior surface and a glass film disposed at the exterior surface. The exterior surface of the substrate has a less curved inboard portion or surface and a more curved outboard portion or surface. The substrate comprises a polymeric resin material. The glass film is adapted to substantially conform to the exterior surface of the wide angle substrate. The glass film comprises a glass material and has a thickness of less than approximately 0.8 mm.

According to another aspect of the present invention, a reflective element for a mirror assembly for a vehicle comprises a substrate having an exterior surface, and an anti-abrasion film applied to the exterior surface. The substrate comprises a polymeric resin material, such as a transparent optical polymeric resin material. The anti-abrasion film preferably comprises a glass material (such as a soda lime glass or a borosilicate or the like) and has a thickness of less than approximately 0.8 mm, and is flexible to conform to the exterior surface.

The substrate may be cut from a strip or sheet of molded or extruded or cast substrate material (or less preferably, may be cut from an injected molded strip or sheet). The flexible glass film may be unrolled from a reel or roll and applied to the exterior surface of the elongated strip or sheet of substrate material. The substrate, including the glass film or layer, may then be cut or otherwise formed from the elongated strip or sheet.

The substrate may comprise a wide angle substrate and/or may comprise a multi-radius exterior surface having a less curved inboard portion or surface and a more curved outboard portion or surface.

A reflective film or layer may be applied to the inner surface or side of the substrate or strip opposite the exterior surface. The reflective film may comprise a polymeric reflective film laminated or otherwise adhered or applied to the inner side of the substrate or strip. The reflective film may comprise an all polymer-thin-film multilayer, high reflective mirror film comprising multiple coextrusion of many plastic layers to form a highly reflective mirror film.

Optionally, a reflective film or layer may be applied to the exterior surface of the substrate or sheet or strip, and the glass film or layer or sheet may be applied over the reflective film layer. In such an application, the substrate acts as a support or backing plate for the reflective film or layer and the glass film or layer, whereby optical clarity/transparency of the substrate material is not necessary.

According to another aspect of the present invention, a method for forming a reflective element substrate for a mirror assembly of a vehicle comprises generally continuously forming an elongated strip or sheet of substrate material and applying a substantially transparent functional film, such as an anti-abrasion film or a hydrophilic film or a hydrophobic film or the like, to a surface of the elongated strip sheet. The substrate material may comprise a transparent optical polymeric resin. The functional film is preferably unrolled from a reel or roll of film and applied to the surface of the elongated strip or sheet generally continuously as the strip or sheet is formed or extruded or cast or molded. Preferably, multiple mirror element shapes or mirror element substrates may be

Explore Litigation Insights

Docket Alarm provides insights to develop a more informed litigation strategy and the peace of mind of knowing you're on top of things.

Real-Time Litigation Alerts



Keep your litigation team up-to-date with **real-time alerts** and advanced team management tools built for the enterprise, all while greatly reducing PACER spend.

Our comprehensive service means we can handle Federal, State, and Administrative courts across the country.

Advanced Docket Research



With over 230 million records, Docket Alarm's cloud-native docket research platform finds what other services can't. Coverage includes Federal, State, plus PTAB, TTAB, ITC and NLRB decisions, all in one place.

Identify arguments that have been successful in the past with full text, pinpoint searching. Link to case law cited within any court document via Fastcase.

Analytics At Your Fingertips



Learn what happened the last time a particular judge, opposing counsel or company faced cases similar to yours.

Advanced out-of-the-box PTAB and TTAB analytics are always at your fingertips.

API

Docket Alarm offers a powerful API (application programming interface) to developers that want to integrate case filings into their apps.

LAW FIRMS

Build custom dashboards for your attorneys and clients with live data direct from the court.

Automate many repetitive legal tasks like conflict checks, document management, and marketing.

FINANCIAL INSTITUTIONS

Litigation and bankruptcy checks for companies and debtors.

E-DISCOVERY AND LEGAL VENDORS

Sync your system to PACER to automate legal marketing.