

German  
Patent and  
Trademark Office

File No. 198 49 978.7  
Date of filing: October 29, 1998  
Date of Publication: May 11, 2000

Applicant:  
Prassler, Erwin, Dr., 80335 Munich, DE;  
Strobel, Engineer, 89079 Ulm, DE

Representative:  
Graf Lambsdorf M.,  
Patent Attorney, 80798 Munich

Inventor(s):  
Prassler, Erwin, Dr. 80335 Munich, DE  
Strobel, Matthias, Engineer, 89079 Ulm, DE

Cited Prior Art:  
DE 43 40 771 A1  
DE – OS 20 04 746  
DE – GM 71 35 880

**The following information was taken from the Applicant's submitted documentation**

Request for Examination has been submitted in accordance with § PatG.

Cleaning unit for the automatic wet cleaning on non-textile floor coverings and autonomously moving cleaning device for housing the cleaning unit

The invention relates to a cleaning unit (10) for automatic or manual wet cleaning of non-textile floor coverings with at least one rotating cleaning cloth (1) laid around numerous rollers (3 – 9), in particular guide and drive rollers, the cleaning cloth forming an outwardly facing surface (1a) and with at least one cleaning container (13) containing a cleaning fluid, through which the cleaning cloth may be led by means of the transport and drive rollers. The cleaning unit can be mounted on a mobile, in particular an autonomously moving cleaning device (20). The autonomously moveable cleaning device can, by means of the cleaning unit and its own navigation system, systematically and over a long period of time, clean a dirty non-textile floor surface without the intervention or support of an operator.

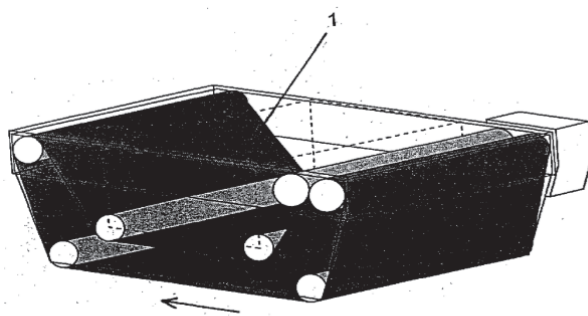

The invention relates to a cleaning unit for automatic wet cleaning of non-textile floor coverings with a rotating cleaning cloth and a cleaning container for the periodic moistening and cleaning of the cleaning cloth during each cycle. In addition, the invention relates to an autonomously moving cleaning vehicle which serves as a carrier vehicle for such cleaning unit and independently moves over the dirty area, thereby automatically cleaning it.

On smooth, as well as lightly structured floors, such as wooden, parquet or tile floors, visible deposits of dirt and dust quickly form which, although they do not constitute a severe soiling, nevertheless lead to a relatively severe deterioration of the floor's optical appearance. This is true both of the floor coverings in households, as well as of those found in public buildings. In particular the large floor surfaces in the entrance halls of heavily frequented buildings such as department stores, museums or banks become rapidly dirty under rainy or wintery weather conditions. According to the present state of the art, the cleaning of such non-textile floor coverings is carried out using mechanically or electrically driven mobile cleaning devices which, although they do produce a satisfying result, can nevertheless generally only be operated manually.

In accordance with the current state of the art, most known automatic or autonomously moving cleaning devices comprise electrically driven rotational cleaning brushes. As one example of this, reference is made to the German Patent Application DE-A-195 44 99, which relates to an autonomously moving cleaning apparatus for floor coverings. This apparatus allows the automatic cleaning of floor coverings, in particular along the area of a wall. It comprises an electrically driven disk-shaped brush by means of which, when in operation, dust and dirt particles are swept into and collected in a dust receptacle. This kind of cleaning is, in contrast to wet cleaning, by nature insufficient, as the dirt is inadequately bound. The additional suggestion to wet the bristles with alcohol does not constitute a significant improvement in binding the dirt.

Cleaning devices having continuous or rotating cleaning belts have also been proposed. In WO 91/1134 a mobile cleaning device is described which comprises a first roller, around which a portion of a cleaning belt is wound and a second electrically driven roller onto which the used cleaning belt is wound up when the device is in operation. On its way from the first to the second roller, the cleaning belt runs over the peripheral segment of an endless belt, thus bringing the underside of the cleaning belt into contact with the floor surface intended to be cleaned. By supplying water from a tank, a wet cleaning of the floor surface can also be carried out. The disadvantage of this device, however, consists in the need for the cleaning belt to be wound up by a second roller after use. This functional principle does not allow the sufficient and efficient wet cleaning of larger floor surfaces. A speedy unwinding and winding up of the cleaning cloth would lead to an improvement of the cleaning results, but would be uneconomical, as the cleaning belt would constantly have

surfaces is described in which a cleaning belt is arranged on the peripheral surface of a roller which rolls on the floor surface to be cleaned and which contacts a rotating fluid transport belt which is immersed into a cleaning fluid contained in a container and which then transfers this cleaning fluid onto the cleaning belt at the point at which they come into contact. As the cleaning belt is only wrung out but is not subject to any additional cleaning, this apparatus is also not designed for the cleaning of larger floor surfaces. Beyond this, the employment of two rotating belts is space consuming, inconvenient and uneconomical.

As opposed to this, the present invention is based on the objective of providing a compact cleaning unit which allows the wet cleaning of a non-textile floor covering and which can be mounted in an autonomously moving cleaning device.

This objective is achieved by means of the designated features of patent claim 1. In accordance with this, the invention relates to a cleaning unit for the automatic or manual cleaning of non-textile floor coverings comprising at least one rotating cleaning cloth laid around numerous rollers, in particular guide and drive rollers, and which forms, on one side of the cleaning unit, an outwardly facing cleaning surface, and further comprising at least one cleaning container which contains a cleaning fluid through which the cleaning cloth can be conveyed by means of the transport and drive rollers. The cleaning cloth can be brought into contact on the outwardly facing cleaning surface with the floor surface intended to be cleaned, thus collecting and binding the dirt located on this surface. The cleaning cloth is periodically rinsed out as it runs through the cleaning container.

Preferably, the cleaning unit comprises a drive motor, by means of which a drive roller, around which the cleaning cloth is laid, is driven. The characteristics of the drive roller's surface are such that they allow the cleaning cloth to be entrained by the roller.

It is also advantageous to arrange a squeezing roller in close proximity to the drive roller, so that the cleaning cloth may be conveyed in between the two rollers and thus wrung out.

The cleaning unit in accordance with the invention presents a compact construction unit which may be mounted on an autonomously moving cleaning device. A central controlling and navigation system that steers the electrically driven vehicle makes it possible for the cleaning device to move autonomously over the soiled floor surface, thereby cleaning it.

In the following, the example embodiments of the cleaning unit in accordance with the invention are described in detail with the aid of the attached figures. These show:

**Figs. 1A to D** show various representations of the individual structural components of one embodiment of a cleaning unit (A – C) in accordance with the invention, and in their entirety without the cleaning cloth (D);

**Fig. 2** shows the cleaning unit of Fig. 1D with a spanned cleaning cloth;

cleaning device;

**Fig. 4** shows the circuitry arrangement for a controlling and navigation system of an autonomously moving cleaning device;

**Figs. 5A to C** show examples of possible trajectories of an autonomously moving cleaning device.

In **Figs. 1A – D** and **2**, example embodiments of a cleaning unit **10** in accordance with the invention are shown. It mainly comprises a cleaning container **13** which is filled with a cleaning fluid, in the simplest case water, as well as numerous rollers **3** to **9**. The rollers comprise a drive roller **3** which is driven by a drive motor **2** and made to rotate (**Fig. 1C**). The drive roller **3** has a surface with a specific roughness or with suitable entrainers, allowing the entrainment of an endless cleaning cloth **1** laid around the drive roller. The first guide rollers **4** to **6** serve to lead the cleaning cloth **1** around the outside of the cleaning container **13**. In operation, the lower guide rollers **5** and **6** span the damp cleaning cloth **1** out to a flat cleaning surface **1a** in the lower segment of the cleaning unit which, when in operation, is in contact with a floor surface intended to be cleaned and cleans the surface by means of a rotating movement. The rotational direction of the cleaning cloth is indicated with an arrow in **Fig. 2**. The guide rollers **4** and **6** are preferably mounted on the cleaning container **13**.

Further, two tensioning and guide rollers **7** and **8** are provided that serve to convey the cleaning cloth into the interior of the cleaning container **13**. The rollers **7** and **8** are attached to an appropriate holder **12** which is fixedly or removably mounted on a container cover **11** (**Figs. 1A, B**). As can be seen in **Fig. 2**, the cleaning cloth runs along the inside of the rollers **7** and **8** and as such is forcibly inserted into the inside of the cleaning container **13**. In this way, the cleaning cloth can be rinsed out by the fluid contained in the cleaning container **13**.

Afterwards the cleaning cloth moves upward again. In the upper segment, in close proximity to the drive roller **3**, a squeezing roller **9** is arranged. The cleaning cloth runs between the squeezing roller **9** and the drive roller **3**, is pressed against the driver roller by the squeezing roller **9** and is thus wrung out. The squeezing roller **9** is mounted on the container cover **11** (**Fig. 1A, B**). The squeezing pressure that is achieved by means of the interaction between the squeezing roller **9** and the adjacent drive roller **3** can be adjusted by selecting the distance between the rollers, i.e. by varying their position in respect to each other. By varying the squeezing pressure, the moisture content of the cleaning cloth can be adjusted.

The cleaning cloth is preferably made of an exchangeable tensile fabric, for example of a knit or nonwoven fiber fleece. Additionally, at appropriate locations sensors may be arranged which detect the degree of dirtiness of the cleaning cloth or the cleaning fluid and which emit, when necessary, a warning signal to notify of the need to replace the cleaning cloth or the cleaning fluid. The cleaning unit may further have an exchangeable drying cloth attached to a rotating roller for the subsequent cleaning and drying of the floor surface,

collect larger dirt particles.

One significant advantage of the cleaning unit is that it is easy to handle and that it can be removed from and replaced in the mobile cleaning device described below in a few easy steps. The cleaning fleece, too, can be replaced in a few quick steps and the cleaning fluid can also be easily exchanged.

In the **Figs. 3A, B** the perspective and bottom views of one embodiment of a mobile cleaning device are shown. The cleaning device has a multi-wheeled, preferably a two-wheeled, as shown, basic vehicle in which the cleaning unit in accordance with the invention is installed. The cleaning device is preferably the approximate size of a vacuum cleaner and moves autonomously with the aid of an electric drive.

When the cleaning unit **10** is installed, the cleaning surface **1a** of the cleaning cloth lies on the floor surface intended to be cleaned. The cleaning cloth **1** is preferably pressed in the region of the cleaning surface **1a** against the floor surface intended to be cleaned by the rollers **5** and **6**. The pressure applied to the surface to be cleaned is generated by the screwing and clamping device with which the cleaning unit is attached in the carrier vehicle. By means of this device, the height of the cleaning unit in relation to the wheels of the vehicle and to the floor surface can be varied and thus the applied pressure adjusted. When the cleaning device is in motion, the drive motor of the cleaning unit is switched on, so that the cleaning cloth, as described, rotates, thus automatically and autonomously cleaning the floor surface. The rotation speed of the cleaning cloth may either be preset or adjustable. The direction of rotation runs preferably against the rotational direction of the wheels and thus against the direction in which the vehicle moves.

The embodiment shown in **Figs. 3A, B** shows a cleaning device with two wheels **21** and **22**. Preferably, the cleaning device has an individual drive motor for each of the wheels in order to allow for the steering of the cleaning device by means of the relative drive forces supplied to the wheels. Numerous distance sensors are arranged at the height of the widest dimension of the vehicle which measure the distance of the vehicle from surrounding obstacles. Upon approaching an obstacle, these supply corresponding signals to a central control unit. In its simplest version, four quarter-circle contact sensors **23a-d** are arranged on the perimeter of the lower part of the housing. Depending on which of the four contact sensors emits a signal, the central control unit initiates a movement to avoid the obstacle. As an alternative to contact sensors, other sensors that detect distance, such as ultrasonic or infrared sensors may also be used.

In **Fig. 4** an example embodiment of a circuit arrangement of a control and navigation system for an autonomously moving cleaning device is shown. The central unit of the circuit arrangement is a control processor **30**. The latter supplies, on the one hand, signals to the power electronics **33** in order to control the drive motors **31, 32** of the wheels **21, 22**, as well as the drive motor **2** of the cleaning unit **10**. On the other hand, the control processor **30** also receives signals from the

actually carried out by the cleaning device.

Movement along a straight line or along an otherwise formed trajectory is achieved by stipulating corresponding speeds and velocity ratios to the drive motors. The physical implementation of the speeds and velocity ratios is carried out by the power electronics by generating corresponding voltage values and voltage ratios and supplying these to the drive motors. The current and voltage supply is provided, for example, by a set of rechargeable 12 V batteries.

By varying the velocity ratios and the corresponding voltage ratios for the drive motors, any desired trajectory can be followed. The control of the velocity ratios and of the actual movement is carried out by the rotary encoders of the drive motors by means of measuring the distance travelled over a specific period of time. If the target speed and/or position differ from the actual speed and/or position, the control processor calculates corresponding compensation values.

The memory unit of the control processor allows, in particular, velocity patterns for specific trajectory patterns to be calculated and stored in advance. In **Figs. 5A to C**, numerous possible trajectories are shown. Accordingly, the cleaning device can move along a spiral formed (**5A**), a meandering (**5B**) or a serpentine formed (**5C**) cleaning trajectory. The selection is carried out by the operator by adjusting a switch. The parameterization of such programmed trajectory types, for example of their width, may optionally be selected by the operator by means of a switch, or it may be hardcoded. Spiral formed (**5A**) and meandering trajectories are generally followed beginning from the inside and moving outwards.

Numerous movement strategies exist for carrying out an all encompassing cleaning using the cleaning device that can be employed combined or individually. The movement can be carried out, for example, on a randomly chosen basis. In this case, the direction of movement and, where appropriate, the distance is (are) selected by the control processor according to a uniform distribution. Movement in a direction randomly chosen in this manner ensures that the floor surface intended to be cleaned will be almost entirely covered in the midterm.

As an alternative to a movement chosen on a random basis, the progression may follow a previously programmed trajectory (for example, **5A**, **5B**, or **5C**). The movement to be followed in this case varies in accordance with the selected trajectory pattern. After completing a corresponding trajectory, thereby carrying out the cleaning of a correspondingly large area, the device moves on in a randomly chosen direction and, after having travelled a predetermined distance, once again starts to carry out a trajectory.

In the event that the cleaning device, while moving straight ahead or along a previously programmed trajectory, is in danger of colliding with an obstacle, this will be reported to the control processor by the distance sensor system **34**. The control processor briefly halts the vehicle, selects at random a new direction of movement away from the obstacle and then resumes the vehicle's progression. The vehicle moves a specified distance in the

By virtue of the combined means of the straight line movement, movement along preset cleaning trajectories and the obstacle avoidance strategies described above, it can be ensured that nearly the entire surface of the floor intended to be cleaned will be covered in the midterm.

Alternatively to the two movement strategies outlined above that allow the combination of random and targeted progression, it is also possible to calculate the cleaning trajectory of a surface to be cleaned entirely, or to a great extent, before carrying it out. For this purpose the vehicle control must be provided with a preferably complete floor plan (outline) of the surface to be cleaned. With the aid of this plan, an all encompassing trajectory can be calculated. In order to ensure that the cleaning trajectory is precisely followed, the vehicle must further be capable of determining its exact position within the cleaning area and of supplementing the floor plan when unidentified objects are detected by its distance sensors. When objects not previously known from the floor plan are detected, the previously calculated cleaning trajectory must be modified to allow the obstacle to be avoided. This can be achieved, for example, by following along the periphery of the obstacle until the original trajectory is once again reached.

#### Claims

1. Cleaning unit (**10**) for automatic or manual cleaning of non-textile floor coverings, with at least one rotating cleaning cloth (**1**) laid around a plurality of rollers (**3-9**), in particular guide and drive rollers (**3-8**), and which forms, on one side of the cleaning unit, an outwardly facing cleaning surface (**1a**), further characterized by having at least one cleaning container (**13**), containing a cleaning fluid, through which the cleaning cloth (**1**) can be conveyed with the aid of the transport and drive rollers (**3-8**).
2. Cleaning unit in accordance with claim 1, characterized by having at least one drive roller (**3**) driven by a motor (**2**), in particular an electric motor, the surface texture of which allows the entrainment of the cleaning cloth (**1**).
3. Cleaning unit in accordance with claim 1, characterized in having a squeezing roller (**9**) by means of which, when in operation, the cleaning cloth (**1**) is pressed against one of the other rollers (**3-8**), in particular the drive roller (**3**), after being conveyed through the cleaning fluid.
4. Cleaning unit in accordance with claim 3, characterized in that the squeezing pressure is adjustable by means of selecting the distance between the rollers, i.e. by varying their position relative to each other.
5. Cleaning unit in accordance with claim 1, characterized by having first guide rollers (**4-6**), by means of which the cleaning belt (**1**) is led around the cleaning container (**13**), wherein the cleaning surface (**1a**) is formed by the segment of the cleaning cloth (**1**) spanned between the guide rollers (**5, 6**).

means of which the cleaning belt **(1)** is forcibly conveyed through the cleaning container, thus undergoing a constant cleaning.

7. Cleaning unit in accordance with claim 1, characterized by having a pressing apparatus, by means of which the cleaning surface **(1a)** of the cleaning cloth **(1)** can be pressed against the surface intended to be cleaned.

9. Cleaning unit in accordance with claim 1, characterized by having an exchangeable drying cloth for the subsequent cleaning and drying of the underlying surface attached to a rotating roller arranged at the end of the cleaning unit.

10. Mobile cleaning device containing a cleaning unit **(10)** in accordance with one or more of the preceding claims containing at least two wheels **(21, 22)**.

11. Cleaning device in accordance with claim 10, characterized in that it is designed as an autonomously moving vehicle **(20)** capable of systematically cleaning a soiled non-textile floor surface over a long period of time without the intervention or support of an operator.

12. Cleaning device in accordance with claim 11, characterized in that it comprises at least two drive motors **(31, 32)** that include power electronics for driving the wheels **(21, 22)**.

13. Cleaning device in accordance with claim 10, characterized in that it comprises a navigation system consisting of a control processor **(30)** for controlling the movement of the cleaning device **(20)**, rotary encoders **(31a, 31b)** for measuring the distance travelled and for determining the position of the cleaning device, and sensors **(23a-d; 34)** for detecting obstacles.

14. Cleaning device in accordance with claim 10, characterized in that it comprises a navigation system offering numerous movement strategies that allow a systematic, all encompassing covering of the floor surface intended to be cleaned.

15. Cleaning device in accordance with claim 10, characterized in that it comprises a navigation system which, by means of distance sensors **(213a-d; 34)**, recognizes that an obstacle is being approached and halts the device.

16. Cleaning device in accordance with claim 10, characterized in that it comprises a navigation device that, after approaching an obstacle and halting the vehicle, initiates a movement allowing the obstacle to be avoided.

---

Attached are 6 pages of figures

---

# Explore Litigation Insights

Docket Alarm provides insights to develop a more informed litigation strategy and the peace of mind of knowing you're on top of things.

## Real-Time Litigation Alerts



Keep your litigation team up-to-date with **real-time alerts** and advanced team management tools built for the enterprise, all while greatly reducing PACER spend.

Our comprehensive service means we can handle Federal, State, and Administrative courts across the country.

## Advanced Docket Research



With over 230 million records, Docket Alarm's cloud-native docket research platform finds what other services can't. Coverage includes Federal, State, plus PTAB, TTAB, ITC and NLRB decisions, all in one place.

Identify arguments that have been successful in the past with full text, pinpoint searching. Link to case law cited within any court document via Fastcase.

## Analytics At Your Fingertips



Learn what happened the last time a particular judge, opposing counsel or company faced cases similar to yours.

Advanced out-of-the-box PTAB and TTAB analytics are always at your fingertips.

## API

Docket Alarm offers a powerful API (application programming interface) to developers that want to integrate case filings into their apps.

## LAW FIRMS

Build custom dashboards for your attorneys and clients with live data direct from the court.

Automate many repetitive legal tasks like conflict checks, document management, and marketing.

## FINANCIAL INSTITUTIONS

Litigation and bankruptcy checks for companies and debtors.

## E-DISCOVERY AND LEGAL VENDORS

Sync your system to PACER to automate legal marketing.