



US 20050058728A1

(19) **United States**
 (12) **Patent Application Publication** (10) **Pub. No.: US 2005/0058728 A1**
Randolph et al. (43) **Pub. Date: Mar. 17, 2005**

(54) **CYTOKINE MODULATORS AND RELATED METHOD OF USE**

(52) **U.S. Cl.** 424/732; 424/765; 424/777

(76) Inventors: **Russell K. Randolph**, Anaheim, CA (US); **Haeri Roh-Schmidt**, Stockton, CA (US)

(57) **ABSTRACT**

Correspondence Address:
WARNER, NORCROSS & JUDD
IN RE: ALTICOR INC.
INTELLECTUAL PROPERTY GROUP
111 LYON STREET, N. W. STE 900
GRAND RAPIDS, MI 49503-2489 (US)

A composition for modulating cytokines to regulate an inflammatory or immunomodulatory response. The composition can include at least one of rosehips, blueberry, blackberry, elderberry, cranberry, rosemary, clove, feverfew, nettle root, artichoke, reishi mushroom, olive extract, green tea extract, grape seed extract, resveratrol, *Aframomum melegueta*, *boswellia serrata* extract, *boswellia forte*, ipriflavone, tocotrienols, evening primrose oil, INM-176, borage oil, krill oil, at least one type of xanthophyll (e.g., astaxanthin), green coffee extract and ferulic acid. Specifically, a composition of the invention can include: rosehips and at least one of blackberry, blueberry, elderberry, and optionally krill oil; or rosehips, resveratrol and at least one of *Aframomum melegueta* and astaxanthin. Based on the cytokine modulation and cytokine response inhibition of the composition, it can be used to regulate an immunomodulatory and/or inflammatory response, and subsequently treat diseases and/or abnormal conditions associated with inflammatory response, for example, cardiovascular conditions, arthritis, osteoporosis and Alzheimer's disease.

(21) Appl. No.: **10/938,093**

(22) Filed: **Sep. 10, 2004**

Related U.S. Application Data

(60) Provisional application No. 60/502,755, filed on Sep. 12, 2003.

Publication Classification

(51) **Int. Cl.⁷** **A61K 35/78**

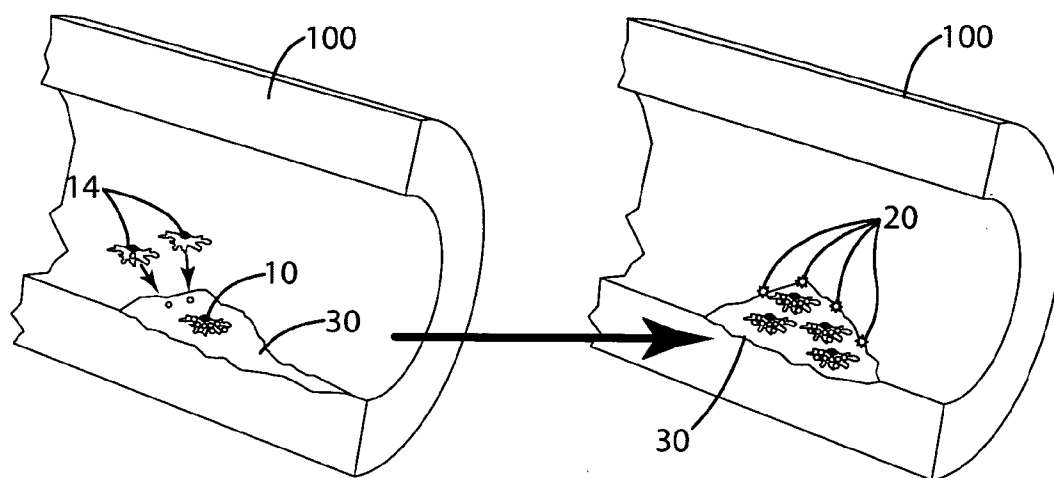

Fig. 1

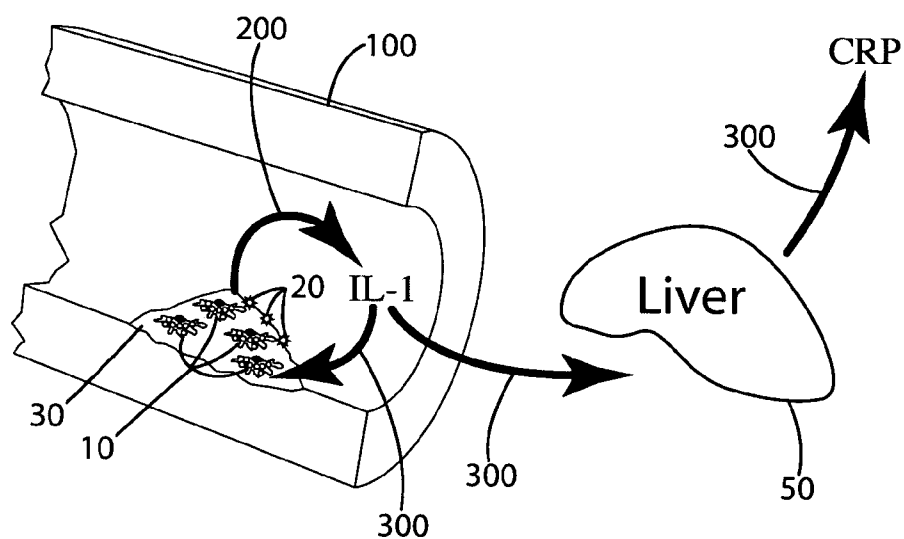

Fig. 2

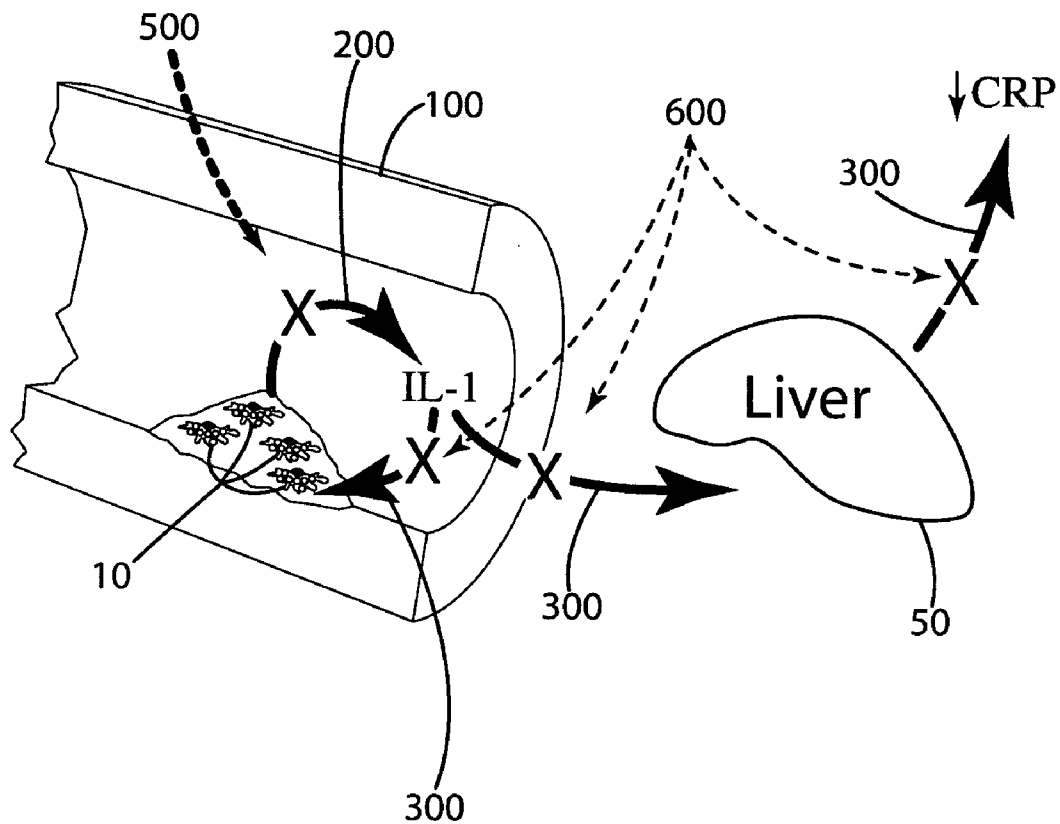

Fig. 3

CYTOKINE MODULATORS AND RELATED METHOD OF USE

[0001] This application claims benefit of U.S. Provisional Application 60/502,755, filed Sep. 12, 2003, which is hereby incorporated by reference.

BACKGROUND OF THE INVENTION

[0002] The present invention relates to inflammation within the body, and more particularly, to regulating inflammation to treat conditions and diseases associated therewith.

[0003] Inflammation has been linked to a variety of conditions and diseases that affect the body. For example, inflammation within joints is known to worsen the symptoms of and structural deformities caused by arthritis and rheumatoid diseases, such as bursitis, tendonitis, myositis and osteoarthritis, as well as bone and joint destructive diseases, such as osteoporosis.

[0004] Inflammation also is known to contribute to a variety of cardiovascular and metabolic disease processes, such as atherosclerosis, thrombosis, and insulin resistance associated with obesity. Atherosclerosis may increase the chances of stroke and myocardial infarction and insulin resistance may lead to diabetes.

[0005] Inflammation is also thought to contribute to the development of neurological disorders, for example, Alzheimer's disease.

[0006] Indeed a large body of research now links inflammation with a wide variety of chronic degenerative diseases. This research has identified certain cells—macrophages—that produce pro-inflammatory chemicals—cytokines—which induce signaling cascades that provide an inflammatory response. These cytokines play a role in inflammatory reaction in response to foreign and infectious agents, traumatic or chronic injury, and abnormal chemical or physical stresses.

[0007] Accordingly, treatments have been developed to regulate the release of inflammatory cytokines, or the signaling of inflammatory cytokines, specifically the interleukin-1 (IL-1) cytokine from macrophages. For example, U.S. Pat. No. 5,635,478 to Vignery discloses the use of calcitonin gene related peptide (CGRP) to regulate IL-1 release, and thereby treat rheumatoid arthritis. Although highly specific CGRP is effective at regulating IL-1, its use is cost prohibitive and presently it is undetermined whether this compound has a toxic effect with prolonged use.

SUMMARY OF THE INVENTION

[0008] The aforementioned problems are overcome in the present invention which provides a composition that regulates interleukin cytokines and/or regulates a physiological response caused by interleukin cytokines. This regulation is effective in controlling an immune response and/or an inflammatory condition. In one aspect, the composition can comprise rosehips and at least one of blackberry, blueberry and elderberry. In another aspect, the composition can comprise rosehips and krill oil. In yet another aspect, the composition can comprise rosehips, blackberry, blueberry,

melegueta. In an even further aspect, the composition can comprise rosehips, resveratrol and astaxanthin.

[0009] In a fourth aspect, the composition can comprise at least one ingredient chosen from rosehips, blueberry, blackberry, elderberry, cranberry, rosemary, clove, feverfew, nettle root, artichoke, reishi mushroom, olive extract, green tea extract (*epigallocatechin gallate*), grape seed extract, resveratrol, *Aframomum melegueta*, *boswellia serrata* extract, *boswellia forte*, ipriflavone, tocotrienols, evening primrose oil, INM-176, borage oil, krill oil, at least one type of xanthophyll (e.g., astaxanthin), green coffee extract (chlorogenic acid), and ferulic acid. In a more specific aspect, the composition can comprise rosehips, nettle root, olive extract and artichoke. In yet another specific aspect, the composition can comprise rose hips, resveratrol and astaxanthin.

[0010] In a fifth aspect, the invention can provide methods for controlling an immune response and/or an inflammatory condition in a subject, the method comprising administering to the subject an effective amount of the composition of the invention to control the immune response and/or the inflammatory condition. In a specific aspect, the composition can inhibit the function of an immunomodulatory or pro-inflammatory cell, for example, a macrophage and/or a leukocyte. In a more specific aspect, the composition can inhibit the expression of the genes that produce interleukin cytokines, for example, by preventing the genetic transcription of those genes. In an even more specific aspect, the composition can inhibit the interleukin cytokine inflammation response mechanism. In these aspects, the composition can reduce and/or eliminate pro-immunomodulatory and/or pro-inflammatory responses in skeletal mass, joints, muscle, tissue, arteries, veins, capillaries, and other organs, systems and/or cells.

[0011] In a sixth aspect, the invention can provide a method of regulating and/or controlling the function of immune cells, such as macrophages, leukocytes and lymphocytes, by administering an effective amount of the composition to a subject.

[0012] In another aspect, the invention can provide a method for regulating cytokine release, also referred to as secretion, from cells in a subject by administering to a subject a cytokine inhibiting amount of the composition.

[0013] In yet another aspect, the invention can provide a method that inhibits the response of cells to an interleukin cytokine by administering to a subject an effective amount of the composition of the invention. In a specific aspect, this administration can modulate the production of inflammation biomarkers, for example, C reactive protein, which is a biomarker produced by the liver that is indicative of excessive inflammation in the body.

[0014] In a ninth aspect, the invention can provide a method for treating a disease or abnormal condition caused by inflammation by administering a therapeutically effective amount of the composition. In a specific aspect, the disease or abnormal condition includes at least one of a cardiovascular disease or condition, thrombosis, a metabolic condition related to insulin resistance and obesity, a traumatic injury, arthritis, osteoporosis, and Alzheimer's disease. In a more specific aspect, the method can include administering the

discomfort following traumatic injuries, surgery or other events that may cause inflammation.

[0015] The present invention provides a composition and related methods for treating a variety of immunomodulatory- and inflammation-based conditions, symptoms and diseases. Because the ingredients used are readily available and relatively inexpensive, the present invention provides a simple and cost-effective solution for treating a variety of inflammation-caused ailments and conditions. Furthermore, because the ingredients are relatively stable, many can be mixed with other materials and provided in a multipurpose supplement or food product.

[0016] These and other objects, advantages and features of the invention will be more readily understood and appreciated by reference to the drawings and the detailed description of the invention.

BRIEF DESCRIPTION OF THE DRAWINGS

[0017] FIG. 1 is a sectional view of a blood vessel of a subject having atherosclerotic plaque development before being treated with the composition of the present invention in Example 3;

[0018] FIG. 2 is a second sectional view of the blood vessel and a liver of a subject that illustrates the effects of interleukin cytokines in atherosclerotic plaque development in Example 3; and

[0019] FIG. 3 is a third sectional view of the blood vessel and the liver of a subject that illustrates the effects of the composition on interleukin cytokines in atherosclerotic plaque development in Example 3.

DETAILED DESCRIPTION OF THE INVENTION

I. The Composition

[0021] A composition of the invention can include one or more ingredients chosen from rosehips, blueberry, blackberry, elderberry, cranberry, rosemary, clove, feverfew, nettle root, artichoke, reishi mushroom, olive extract, green tea extract (*epigallocatechin gallate*), grape seed extract, resveratrol, *Aframomum melegueta*, *boswellia serrata* extract, *boswellia forte*, ipriflavone, tocotrienols, evening primrose oil, INM-176, borage oil, krill oil, at least one type of xanthophyll (e.g., astaxanthin), green coffee extract (chlorogenic acid), and ferulic acid. Specifically, a composition of the invention can include rosehips and at least one of blackberry, blueberry, elderberry and krill oil. A composition also can include rosehips, resveratrol and *Aframomum melegueta*. Another composition can include rosehips, resveratrol and astaxanthin. The composition can be administered in any of the dosages recited herein to inhibit cytokine expression, production, reception, secretion and/or release, as well as inhibit the cytokine response, thereby reducing or eliminating an immunomodulatory and/or inflammatory response.

[0022] Acceptable dosages of the ingredients that may be effective at modulating cytokines, for example, regulating the production, reception, secretion and/or release of exemplary cytokines, such as IL-1 and/or IL-6, are presented in

dosages in Table I are presented in ranges of from about the recited lower limit to about the upper limit. For example, the nettle Dosage A recites “250-2500”, which represents a dosage of about 250 to about 2500 milligrams of nettle per day.

TABLE I

Acceptable Dosages for Ingredients to Modulate Cytokines		
Ingredient	Dosage A	Dosage B
Nettle extract	250-2500	500-1250
Artichoke	150-1500	300-750
Feverfew	50-500	100-250
Reishi mushroom	300-3000	600-1500
Olive extract	300-3000	600-1500
Green tea extract	150-1500	300-750
Grape seed extract	100-1000	200-500
<i>Aframomum melegueta</i> extract	150-1500	300-750
<i>Boswellia serrata</i> extract	350-3500	700-1750
Ipriflavone	100-1000	200-500
Tocotrienols	50-500	100-250
Evening primrose oil	500-5000	1000-2500
INM-176	100-1000	200-500
Borage Oil	500-5000	1000-2500
Krill Oil	300-3000	600-1500
Green coffee extract (chlorogenic acid)	100-1000	200-500
Ferulic acid	100-1000	200-500
Rosehips	50-500	500-5000
Blackberry powder	100-1000	200-500
Blueberry powder	200-2000	300-1500
Cranberry extract	100-1000	200-500
Rosemary extract	100-1000	200-500
Clove extract	100-1000	200-500
Resveratrol	100-1000	200-500
Elderberry extract	400-4000	700-2500

[0023] The ingredients identified above in Table I are readily commercially available. Depending on the application and/or the supplier, the ingredient may be an extract of a specific potency, a pure ingredient, an ingredient mixed with excipients, and in a variety of physical forms, e.g., liquid or powder. The ingredient identified is INM-176 is a compound of unknown composition available from Scigenic Company, Ltd. of Seoul, Korea.

[0024] More particularly, the composition can include one or more than one rosehip ingredient. Examples of rosehip ingredients include, without limitation, dried rosehips, rosehip oil, and rosehip extracts. A rosehip ingredient can be obtained from any of the multiple species of plants that belong to the *Rosa* family, for example *Rosa canina*. Moreover, rosehips can include the fruit, petals and/or seeds of the *Rosa* plants.

[0025] Any method can be used to prepare a rosehips ingredient. As an example, conventional harvesting and drying methods can be used to prepare dried rosehips. Rosehip oil can be produced with standard methods and processed with cellulose for tableting or powdered compositions. In addition, rosehips can be obtained commercially from MB North America of Torrance, Calif.

[0026] A composition of the invention can contain one or more than one rosehips ingredient. For example, a dietary supplement can contain dried rosehips as well as rosehips extract. In addition, a composition can contain any amount of a rosehips component. For example, at least about 1

Explore Litigation Insights

Docket Alarm provides insights to develop a more informed litigation strategy and the peace of mind of knowing you're on top of things.

Real-Time Litigation Alerts



Keep your litigation team up-to-date with **real-time alerts** and advanced team management tools built for the enterprise, all while greatly reducing PACER spend.

Our comprehensive service means we can handle Federal, State, and Administrative courts across the country.

Advanced Docket Research



With over 230 million records, Docket Alarm's cloud-native docket research platform finds what other services can't. Coverage includes Federal, State, plus PTAB, TTAB, ITC and NLRB decisions, all in one place.

Identify arguments that have been successful in the past with full text, pinpoint searching. Link to case law cited within any court document via Fastcase.

Analytics At Your Fingertips



Learn what happened the last time a particular judge, opposing counsel or company faced cases similar to yours.

Advanced out-of-the-box PTAB and TTAB analytics are always at your fingertips.

API

Docket Alarm offers a powerful API (application programming interface) to developers that want to integrate case filings into their apps.

LAW FIRMS

Build custom dashboards for your attorneys and clients with live data direct from the court.

Automate many repetitive legal tasks like conflict checks, document management, and marketing.

FINANCIAL INSTITUTIONS

Litigation and bankruptcy checks for companies and debtors.

E-DISCOVERY AND LEGAL VENDORS

Sync your system to PACER to automate legal marketing.