

**DESIGNLINES** | AUTOMOTIVE DESIGNLINE

Modulation Schemes: Moving Digital Data With Analog Signals

By [Andrew W. Davis](#), 10.04.97 0

Modulations are the techniques to carry digital data over analog waveforms. This rather arcane subject has been brought to the forefront of the DSP, EE, and telecommunications worlds by the ongoing interest in broadband communications, specifically, the great opportunity represented by bringing low cost broadband communications to the home. Think what it would be like to log on to the Internet or to the corporate LAN at speeds of over a megabit per second. The potential is enormous. The phone companies are approaching this opportunity with a grab bag of technologies known as DSL, digital subscriber loops. Many articles have appeared recently on ADSL, RDSL, SDSL, HDSL, MDSL, and VDSL. These will be covered in more depth in future newsletters. The cable companies are offering broadband services with cable modems. In either case, modulations are one of the fundamental technologies.

The modulation process places (analog or digital) signal information onto sinewave carriers while demodulation reverses the process at the receiving end. Modulation schemes are very much in the news today because newer algorithms that take advantage of newer and more powerful DSP architectures make possible faster and more reliable communications than was possible before. However, modulation changes, with few exceptions, are incompatible with previous schemes, making the economic cost of improvements very high if there is an installed base of users or equipment to worry about.

As you will see below, there are many types of modulation schemes available today. In the xDSL marketplace, there is an active marketing war going on between those in the CAP camp and those vendors in the DMT camp. A companion article in this newsletter from Rupert Baines of Analog Devices goes a long way towards explaining the CAP vs. DMT debates. Another technology camp where modulations are very much in the news is the cable modem camp. The cable operator companies have banded together to sort out these issues in order to bring a measure of standardization to their industry. These standardization issues are outside the scope of this newsletter. The information below is an overview to help you sort through the issues.

Analog modulation processes perform their magic by changing one or more of the three characteristics of a sine wave: amplitude, frequency, and phase.

Digital modulation applies a digital data stream to the carrier and makes the data stream compatible with the RF communications channel. Each wave state generated in this way represents one symbol of data (each symbol is an N-bit word where N is a power of two from 1 to 8, depending on the technology used). The resulting modulations schemes are called amplitude shift keying, frequency shift keying, and phase shift keying. In RF communications however, the two main approaches are phase shift (constant amplitude) and amplitude shift. The number of symbols per second transmitted is known as the baud rate. The number of bits per second equals (symbols per second) multiplied by (bits per symbol).

When it comes to modulations, the lack of standards becomes quite evident. A hodgepodge of modulation techniques with a range of price/performance features are in use today, although the cable modem industry seems to be settling on a de-facto turn to a 64-QAM (N=6) or 256-QAM (N=8) delivery model for downstream data, and QPSK for a moderate bit-rate return path.

All modulation schemes can be judged by their spectral efficiency and by their error rates. Spectral efficiency is the input digital rate divided by the allocated RF channel bandwidth. The unit of measure is "bits/Hz." The error rate (usually failed bits per million or bits per billion of "good" bits) is a function of several factors, including susceptibility to noise and interference, susceptibility to fading, and non-linearities, which can arise due to dependencies on signal frequency and amplitude. In general, as spectral efficiency increases, so unfortunately does the error rate, which means a higher signal-to-noise ratio might be needed to achieve acceptable error rates.

There are several ways to achieve more than one bit/Hz of throughput. Instead of simple binary encoding, the system can define four different voltages or phases for a single wave cycle, allowing one cycle to represent a two-bit symbol. If both phase and amplitude can vary simultaneously over four values, then one cycle can represent one of 16 discrete logical states. This squeezes 4 bits of data into a single wave cycle, or 4 bits/Hz. Much of the work on modulation techniques currently benefiting the cable modem industry stems from interest in digital video and from technology developed for telephony. While MPEG-2 is becoming the digital video standard for the broadcast industry, digital modulation techniques allow vendors to squeeze 6 or more digital channels into the 6 MHz space normally used for a single analog channel. This is one of digital video's major benefits (and is the basis for much of the talk about 500 cable channels in the future).

The set of available transmission symbols in a particular modulation scheme is known as its alphabet while a graph of the alphabet on a complex plane is known as the constellation (see examples below). After symbols have been formed and converted to complex numbers, the constellation diagram is drawn by plotting the real part, I, and complex (or imaginary) part, Q, on a 2-D map.

Carrierless Amplitude Modulation/Phase Modulation (CAP)

CAP is a bandwidth-efficient two-dimensional passband line code derived from QAM by AT&T Bell Labs as part of an effort to produce a variant of QAM that could be efficiently implemented on a digital signal processor. 16-CAP has been adopted by DAVIC, the Digital Audio-Visual Interoperability Council, for interactive TV and video-on-demand applications and is proposed for SVD systems. In 16-CAP, blocks of four bits are mapped into one of 16 possible 2-D symbols in each symbol period. Two bits represent the quadrant, two bits identify a symbol within the quadrant. Increasing the number of bits per symbol increases bandwidth efficiency. But the modulation scheme also becomes more sensitive to noise. This is the basis of any modulation tradeoff. In Switched Digital Video systems, 16-CAP squeezes 51.84 Mbps into a downstream signal occupying approximately 20 MHz of bandwidth.

Code Division Multiple Access (CDMA)

CDMA is a form of spread spectrum transmission which works by coding and spreading the information to be transmitted over a wide band. CDMA is asynchronous, and typically uses a 30 MHz bandwidth. CDMA used by some vendors, like Zenith and Cisco, who believe the spread spectrum approach to be superior in noisy upstream environments. Maximum digital bandwidth is approximately 10 Mbps over cable.

Coded Orthogonal Frequency Division Multiplexing (COFDM)

COFDM is an experimental approach, intended for broadcast TV, which works by taking the transmitted data and spreading it over a large number of carriers, rather than modulating it all onto a single carrier.

Hence, COFDM creates a large number of parallel paths, each of which carries data at a slower rate than the overall signal. The longer symbol times are more resistant to system noise. The data on the carriers can be modulated using one of the standard digital modulation schemes such as QPSK, 16-QAM, 64-QAM, or 256-QAM. Data is spread redundantly over many carriers so that a loss of some carriers leads only to loss of an occasional bit, a problem which can be corrected for at the receiving (forward-error correction) end. ADC Telecom uses orthogonal frequency division multiplexing for its cable-based telephony product to modulate 240 individual DS0 channels into a 5MHz spectrum with 0.5 MHz guardband on either side. This is very attractive to a cable operator with only 18 MHz usable upstream bandwidth. While OFDM has many advantages, it requires more signal processing horsepower at the headend than do some of the other modulation techniques.

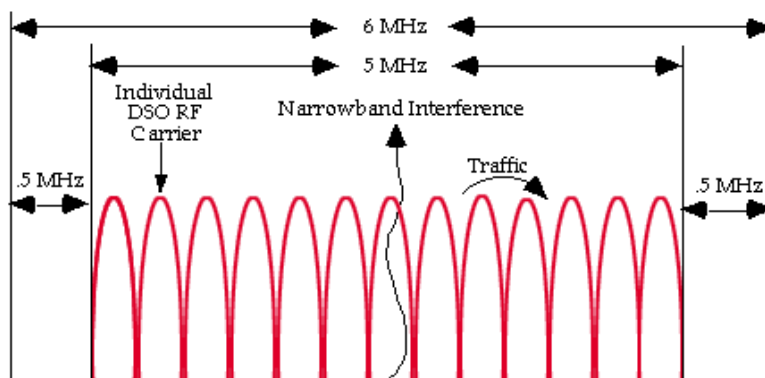

Figure 1: OFDM breaks the channel into many subchannels and shifts traffic to a clear channel when needed.

Quadrature Amplitude Modulation (QAM)

QAM systems combine PSK and ASK to increase the number of states per symbol. QAM is a proven technique for the transmission of digital data over a wide range of channels from voiceband modems at 9600 bps to microwave links transmitting hundreds of Mbps. QAM is also the modulation technique used by V.34 modems. Each symbol value represents multiple bits. 16-QAM carries 4 bits per symbol while 256-QAM carries 8 bits per symbol. The signal-to-noise ratio at the receiver determines the QAM level that can be used reliably on a given transmission channel. Typical terrestrial and cable channels allow 16-QAM and 256-QAM, leading to digital data rates of approximately 20 and 40 Mbps, respectively.

In a typical cable TV application, 64-QAM can squeeze a 30 Mbps data stream into a 6 MHz (bandwidth) TV channel. QAM is also of use for digital video broadcast. Note that for video-on-demand or MPEG-based broadcast video delivery, 64-QAM allows five channels of 6 Mbps video for each analog channel allocation. For telephony, which uses 64 kbps data streams, a single "video channel" could handle over 450 downstream phone calls, which would be time-division multiplexed within the datastream. Hence, in 750 MHz cable systems, the upper 240 MHz can contain up to 1000 3-Mbps datastreams, each carrying a unique digital address that directs it to a particular set-top box or cable modem (used for video on demand, or VOD). QAM is used in some upstream traffic designs, but is less noise resistant, though more bit-efficient, than QPSK.

It is easier to visualize QAM by looking at 16-QAM. QAM separates points widely and is hence fairly noise immune. The system for 16-QAM combines 4 input bits to produce 1 signal burst. Both phase and amplitude are modulated. Odd-numbered bits in the input stream are combined in pairs to form one of 4 levels which modulate the sine term. Even-numbered bits are similarly combined to modify the cosine term. Sine and cosine terms are then combined.

$$V(t) = x(t) \cos 1/2t + y(t)\sin 1/2t$$

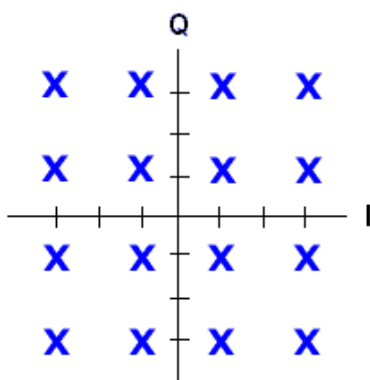

Figure 2: I-Q diagram or constellation for 16-QAM scheme.

16-QAM has better spectral efficiency than 8-PSK and is less sensitive to noise than 16-PSK because the spacings between symbols are larger (see diagrams below). This is true because the symbols are not all on the same circle; the resultant signals are not all of the same amplitude.

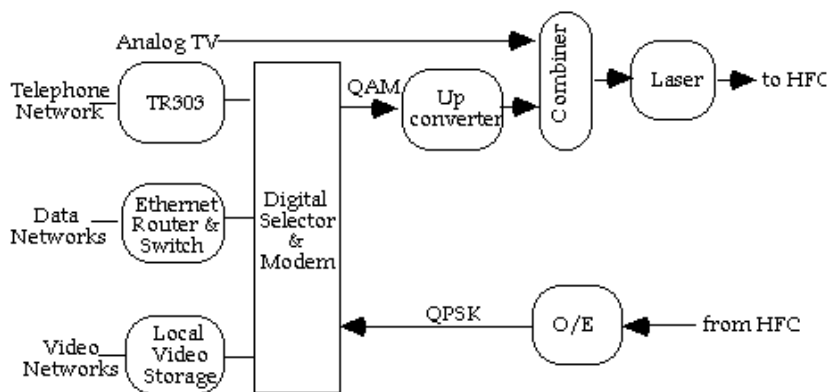

Figure 3: Digital multiplexing of data, video, and voice services in the cable headend.

Quadrature Phase Shift Keying (QPSK)

QPSK (which is QAM without an amplitude component) has become the preferred modulation format for the upstream. QPSK is inherently robust and economical. While other modulation techniques have been proposed with efficiencies higher than the 1.5 bits/Hz of QPSK, these formats have yet to be tested as thoroughly. QPSK has been selected by DAVIC as the upstream modulation format, and is the current front-runner for selection by the IEEE 802.14 committee. QPSK is also used in many satellite systems.

QPSK involves channel hopping until a clear path is found. QPSK is sometimes called four-phase PSK; the phase of the carrier can take on one of 4 values. Each transmitted symbol represents two bits.

- 00 Acos(wt)
- 01 Acos(wt+90)

10 $\text{Acos}(wt+180)$
 11 $\text{Acos}(wt+270)$

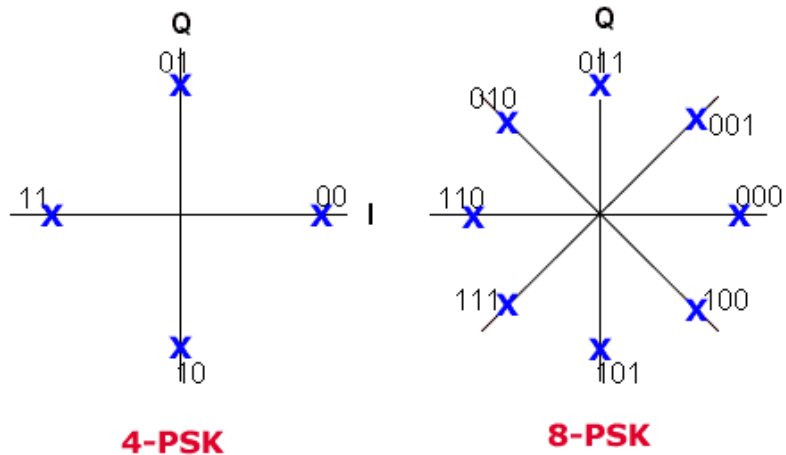

Figure 4: Constellations for QPSK (4-PSK) and 8-PSK

The system is less bit-efficient, but more noise-resistant and has advantages in its ability to operate over long distances with many interfering sources such as those found in a neighborhood cable network. For this reason, QPSK is favored for upstream traffic in cable modem applications. QPSK delivers about 1.5 bits per Hertz of bandwidth used. QPSK can go up to 10 Mbps in cable systems, but uses up a large portion of the available upstream bandwidth. Hence, most symmetrical cable modem products are expected to be limited to 10 Mbps. QPSK is also used for cable-based telephony applications (as well as some set-top box designs). Approximately 50 kHz of bandwidth is required for one DS0 channel (64 kbps). Individual channels are assigned to callers on a per-call basis anywhere within the 6-to-42 MHz band (downstream telephony modulations are different. Up to 72-64 kbps DS0 channels are packaged within a single 3 MHz slot in the 50-to-750 MHz region).

Explore Litigation Insights

Docket Alarm provides insights to develop a more informed litigation strategy and the peace of mind of knowing you're on top of things.

Real-Time Litigation Alerts



Keep your litigation team up-to-date with **real-time alerts** and advanced team management tools built for the enterprise, all while greatly reducing PACER spend.

Our comprehensive service means we can handle Federal, State, and Administrative courts across the country.

Advanced Docket Research



With over 230 million records, Docket Alarm's cloud-native docket research platform finds what other services can't. Coverage includes Federal, State, plus PTAB, TTAB, ITC and NLRB decisions, all in one place.

Identify arguments that have been successful in the past with full text, pinpoint searching. Link to case law cited within any court document via Fastcase.

Analytics At Your Fingertips



Learn what happened the last time a particular judge, opposing counsel or company faced cases similar to yours.

Advanced out-of-the-box PTAB and TTAB analytics are always at your fingertips.

API

Docket Alarm offers a powerful API (application programming interface) to developers that want to integrate case filings into their apps.

LAW FIRMS

Build custom dashboards for your attorneys and clients with live data direct from the court.

Automate many repetitive legal tasks like conflict checks, document management, and marketing.

FINANCIAL INSTITUTIONS

Litigation and bankruptcy checks for companies and debtors.

E-DISCOVERY AND LEGAL VENDORS

Sync your system to PACER to automate legal marketing.