

Under the Paperwork Reduction Act of 1995, no persons are required to respond to a collection of information unless it displays a valid OMB control number.

TRANSMITTAL FOR POWER OF ATTORNEY TO ONE OR MORE REGISTERED PRACTITIONERS

NOTE: This form is to be submitted with the Power of Attorney by Applicant form (PTO/AIA/82B) to identify the application to which the Power of Attorney is directed, in accordance with 37 CFR 1.5, unless the application number and filing date are identified in the Power of Attorney by Applicant form. If neither form PTO/AIA/82A nor form PTO/AIA82B identifies the application to which the Power of Attorney is directed, the Power of Attorney will not be recognized in the application.

Application Number	Unknown
Filing Date	Herewith
First Named Inventor	James H. Jannard et al.
Title	VIDEO CAMERA
Art Unit	Unknown
Examiner Name	Unknown
Attorney Docket Number	REDCOM.007C4

SIGNATURE of Applicant or Patent Practitioner

Signature	/Sean Ambrosius/	Date (Optional)	09/12/2014
Name	Sean Ambrosius	Registration Number	65,290
Title (if Applicant is a juristic entity)	Attorney of Record		
Applicant Name (if Applicant is a juristic entity)	REDCOM, INC.		

NOTE: This form must be signed in accordance with 37 CFR 1.33. See 37 CFR 1.4(d) for signature requirements and certifications. If more than one applicant, use multiple forms.

*Total of 1 forms are submitted.

This collection of information is required by 37 CFR 1.131, 1.32, and 1.33. The information is required to obtain or retain a benefit by the public which is to file (and by the USPTO to process) an application. Confidentiality is governed by 35 U.S.C. 122 and 37 CFR 1.11 and 1.14. This collection is estimated to take 3 minutes to complete, including gathering, preparing, and submitting the completed application form to the USPTO. Time will vary depending upon the individual case. Any comments on the amount of time you require to complete this form and/or suggestions for reducing this burden, should be sent to the Chief Information Officer, U.S. Patent and Trademark Office, U.S. Department of Commerce, P.O. Box 1450, Alexandria, VA 22313-1450. DO NOT SEND FEES OR COMPLETED FORMS TO THIS ADDRESS. **SEND TO: Commissioner for Patents, P.O. Box 1450, Alexandria, VA 22313-1450.**

If you need assistance in completing the form, call 1-800-PTO-9199 and select option 2.

POWER OF ATTORNEY BY APPLICANT

I hereby revoke all previous powers of attorney given in the application identified in either the attached transmittal letter or the boxes below.

Application Number	Filing Date

(Note: The boxes above may be left blank if information is provided on form PTO/AIA/82A.)

- I hereby appoint the Patent Practitioner(s) associated with the following Customer Number as my/our attorney(s) or agent(s), and to transact all business in the United States Patent and Trademark Office connected therewith for the application referenced in the attached transmittal letter (form PTO/AIA/82A) or identified above: 20995
- OR
- I hereby appoint Practitioner(s) named in the attached list (form PTO/AIA/82C) as my/our attorney(s) or agent(s), and to transact all business in the United States Patent and Trademark Office connected therewith for the patent application referenced in the attached transmittal letter (form PTO/AIA/82A) or identified above. (Note: Complete form PTO/AIA/82C.)

Please recognize or change the correspondence address for the application identified in the attached transmittal letter or the boxes above to:

- The address associated with the above-mentioned Customer Number
- OR
- The address associated with Customer Number:
- OR

Firm or Individual Name					
Address					
City	State	Zip			
Country					
Telephone	Email				

I am the Applicant (if the Applicant is a juristic entity, list the Applicant name in the box).

RED.COM, Inc.

- Inventor or Joint Inventor (title not required below)
- Legal Representative of a Deceased or Legally Incapacitated Inventor (title not required below)
- Assignee or Person to Whom the Inventor is Under an Obligation to Assign (provide signer's title if applicant is a juristic entity)
- Person Who Otherwise Shows Sufficient Proprietary Interest (e.g., a petition under 37 CFR 1.46(b)(2) was granted in the application or is concurrently being filed with this document) (provide signer's title if applicant is a juristic entity)

SIGNATURE of Applicant for Patent

The undersigned (whose title is supplied below) is authorized to act on behalf of the applicant (e.g., where the applicant is a juristic entity).

Signature		Date (Optional)	
Name	Peter Jarred Land		
Title	President		

NOTE: Signature - This form must be signed by the applicant in accordance with 37 CFR 1.33. See 37 CFR 1.4 for signature requirements and certifications. If more than one applicant, use multiple forms.

Total of 1 forms are submitted.

This collection of information is required by 37 CFR 1.131, 1.32, and 1.33. The information is required to obtain or retain a benefit by the public which is to file (and by the USPTO to process) an application. Confidentiality is governed by 35 U.S.C. 122 and 37 CFR 1.11 and 1.14. This collection is estimated to take 3 minutes to complete, including gathering, preparing, and submitting the completed application form to the USPTO. Time will vary depending upon the individual case. Any comments on the amount of time you require to complete this form and/or suggestions for reducing this burden, should be sent to the Chief Information Officer, U.S. Patent and Trademark Office, U.S. Department of Commerce, P.O. Box 1450, Alexandria, VA 22313-1450. DO NOT SEND FEES OR COMPLETED FORMS TO THIS ADDRESS. SEND TO: Commissioner for Patents, P.O. Box 1450, Alexandria, VA 22313-1450.

If you need assistance in completing the form, call 1-800-PTO-9199 and select option 2.

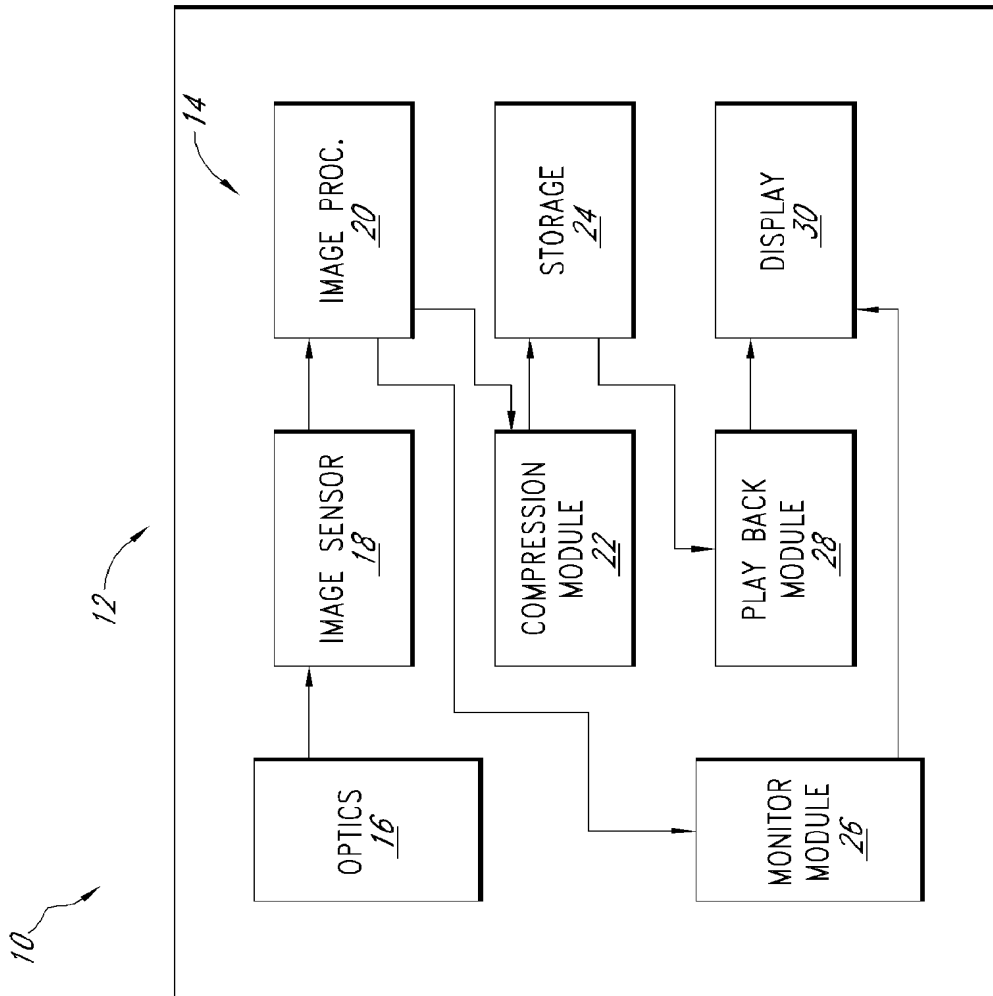

FIG. 1

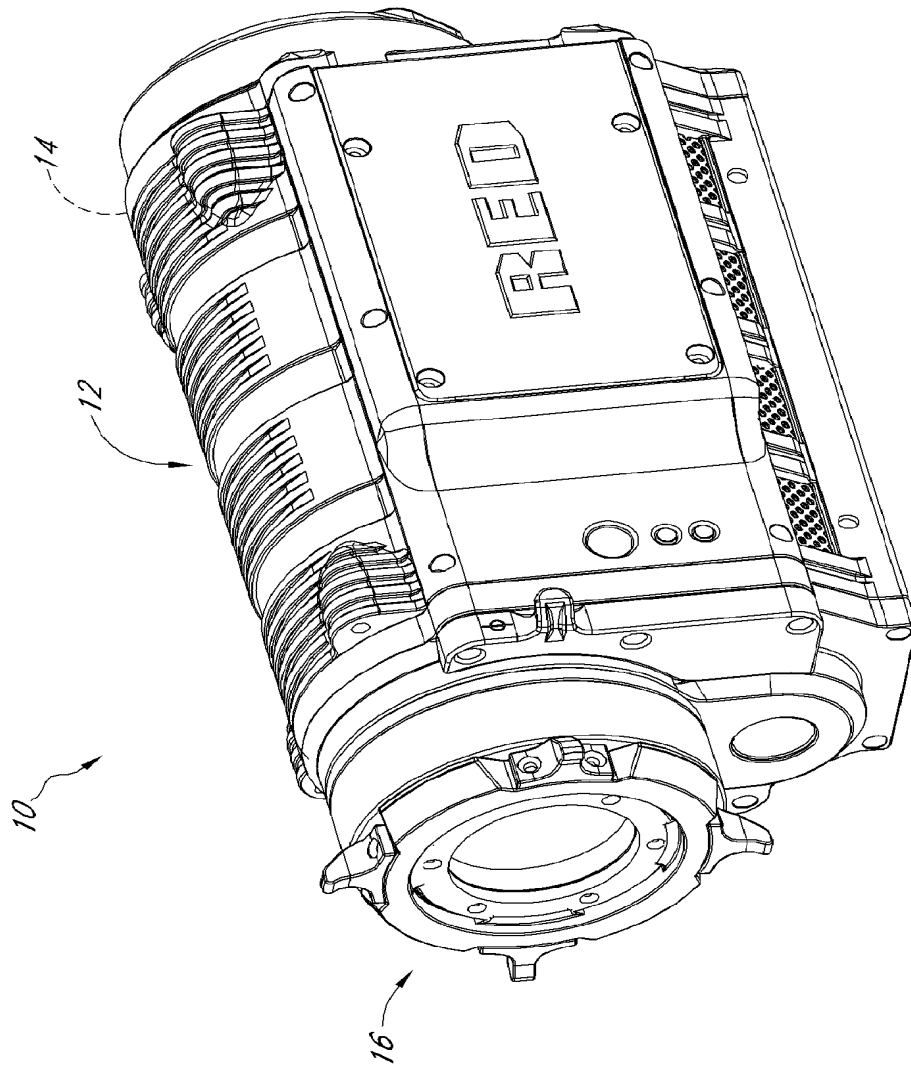

FIG. 2

	$m-3$	$m-2$	$m-1$	m	$m+1$	$m+2$	$m+3$	$m+4$
$n-3$	$B_{m-3,n-3}$	$G_{m-2,n-3}$	$B_{m-1,n-3}$	$G_{m,n-3}$	$B_{m+1,n-3}$	$G_{m+2,n-3}$	$B_{m+3,n-3}$	$G_{m+4,n-3}$
$n-2$	$G_{m-3,n-2}$	$R_{m-2,n-2}$	$G_{m-1,n-2}$	$R_{m,n-2}$	$G_{m+1,n-2}$	$R_{m+2,n-2}$	$G_{m+3,n-2}$	$R_{m+4,n-2}$
$n-1$	$B_{m-3,n-1}$	$G_{m-2,n-1}$	$B_{m-1,n-1}$	$G_{m,n-1}$	$B_{m+1,n-1}$	$G_{m+2,n-1}$	$B_{m+3,n-1}$	$G_{m+4,n-1}$
n	$G_{m-3,n}$	$R_{m-2,n}$	$G_{m-1,n}$	$R_{m,n}$	$G_{m+1,n}$	$R_{m+2,n}$	$G_{m+3,n}$	$R_{m+4,n}$
$n+1$	$B_{m-3,n+1}$	$G_{m-2,n+1}$	$B_{m-1,n+1}$	$G_{m,n+1}$	$B_{m+1,n+1}$	$G_{m+2,n+1}$	$B_{m+3,n+1}$	$G_{m+4,n+1}$
$n+2$	$G_{m-3,n+2}$	$R_{m-2,n+2}$	$G_{m-1,n+2}$	$R_{m,n+2}$	$G_{m+1,n+2}$	$R_{m+2,n+2}$	$G_{m+3,n+2}$	$R_{m+4,n+2}$
$n+3$	$B_{m-3,n+3}$	$G_{m-2,n+3}$	$B_{m-1,n+3}$	$G_{m,n+3}$	$B_{m+1,n+3}$	$G_{m+2,n+3}$	$B_{m+3,n+3}$	$G_{m+4,n+3}$
$n+4$	$G_{m-3,n+4}$	$R_{m-2,n+4}$	$G_{m-1,n+4}$	$R_{m,n+4}$	$G_{m+1,n+4}$	$R_{m+2,n+4}$	$G_{m+3,n+4}$	$R_{m+4,n+4}$

FIG. 3

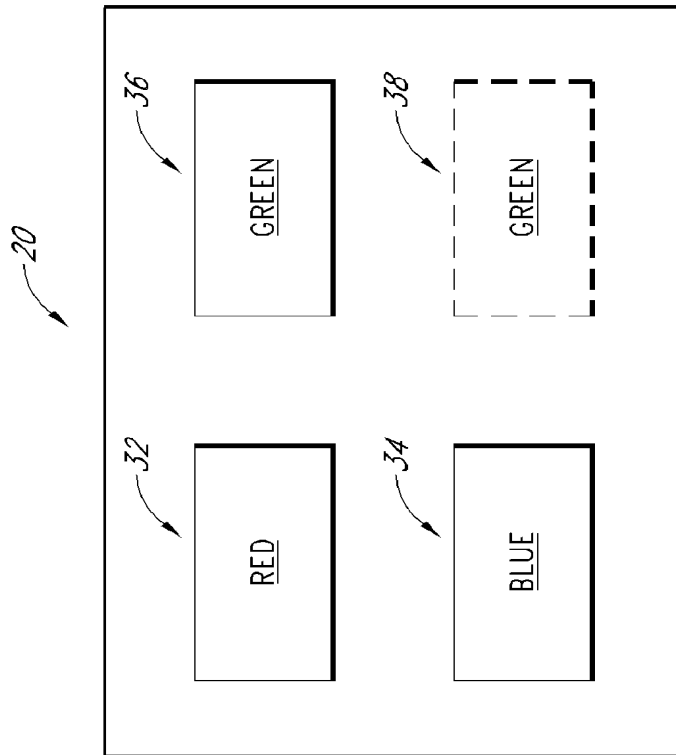

FIG. 4

$m-3$		$G_{m-2,n-3}$			$G_{m,n-3}$			$G_{m+2,n-3}$			$G_{m+4,n-3}$
$m-2$	$G_{m-3,n-2}$		$G_{m-1,n-2}$							$G_{m+3,n-2}$	
$m-1$		$G_{m-2,n-1}$			$G_{m,n-1}$			$G_{m+2,n-1}$			$G_{m+4,n-1}$
m											
$m+1$			$G_{m-1,n}$		$G_{m,n}$			$G_{m+1,n}$			
$m+2$	$G_{m-2,n+1}$									$G_{m+3,n}$	
$m+3$		$G_{m-2,n+2}$			$G_{m,n+1}$			$G_{m+2,n+1}$			$G_{m+4,n+1}$
$m+4$			$G_{m-1,n+2}$							$G_{m+3,n+2}$	
$n-3$											
$n-2$											
$n-1$											
n	$G_{m-3,n}$										
$n+1$											
$n+2$		$G_{m-3,n+2}$									
$n+3$											
$n+4$	$G_{m-3,n+4}$									$G_{m+3,n+4}$	

FIG. 5

$n-3$								
$n-2$	$G_{m-3,n-2}$		$G_{m-1,n-2}$	$G_{m+1,n-2}$	$G_{m+3,n-2}$			
$n-1$								
n	$G_{m-3,n}$		$G_{m-1,n}$	$G_{m+1,n}$	$G_{m+3,n}$			
$n+1$								
$n+2$	$G_{m-3,n+2}$		$G_{m-1,n+2}$	$G_{m+1,n+2}$	$G_{m+3,n+2}$			
$n+3$								
$n+4$	$G_{m-3,n+4}$		$G_{m-1,n+4}$	$G_{m+1,n+4}$	$G_{m+3,n+4}$			

FIG. 6

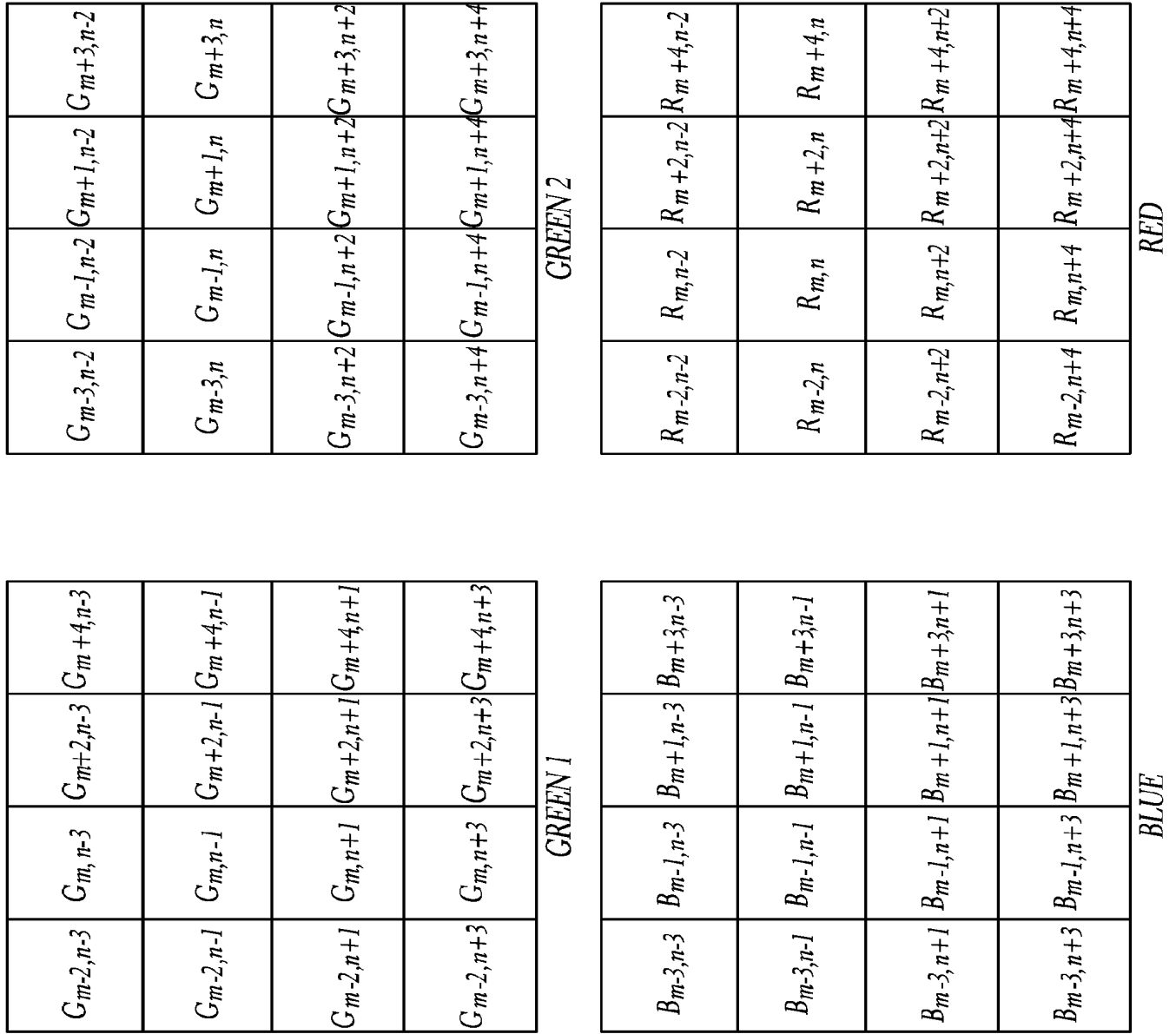

FIG. 7

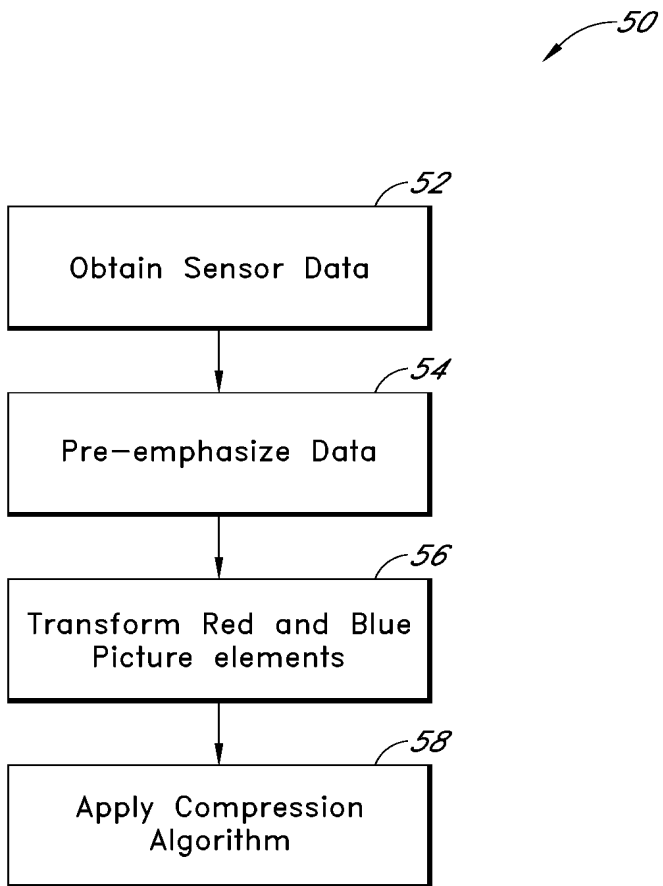

FIG. 8

50'

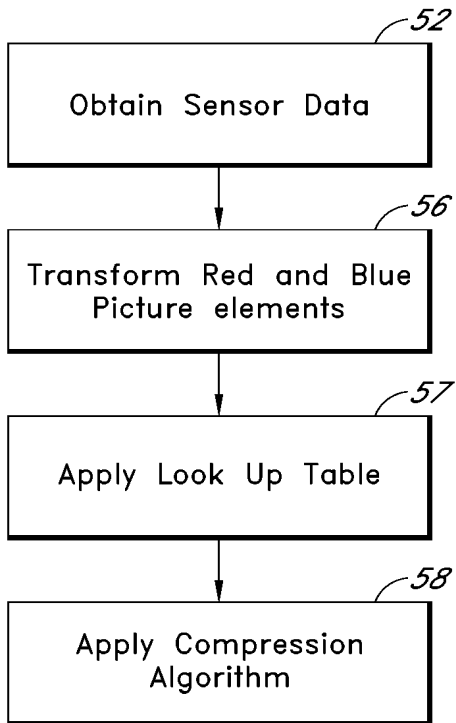

FIG. 8A

	$\begin{aligned} B'_{m-1,n-1} = \\ B_{m-1,n-1} - \\ (G_{m-1,n-2} + G_{m,n-1} + \\ G_{m-1,n} + G_{m-2,n-1})/4 \end{aligned}$		

FIG. 9

	$R'_{m-2,n-2} =$ $R_{m-2,n-2} -$ $(G_{m-2,n-3} + G_{m-1,n-2} +$ $G_{m-2,n-1} + G_{m-3,n-2})/4$		

FIG. 10

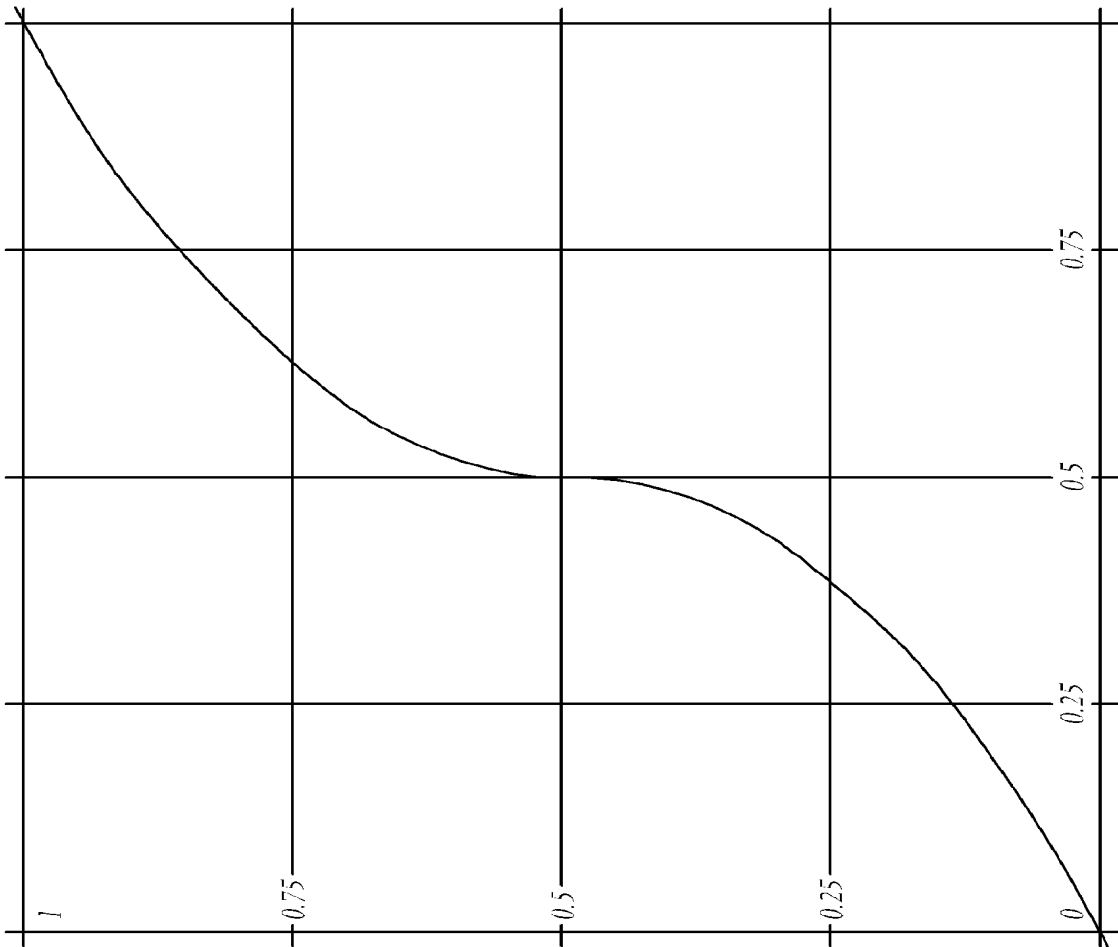

FIG. 11

60

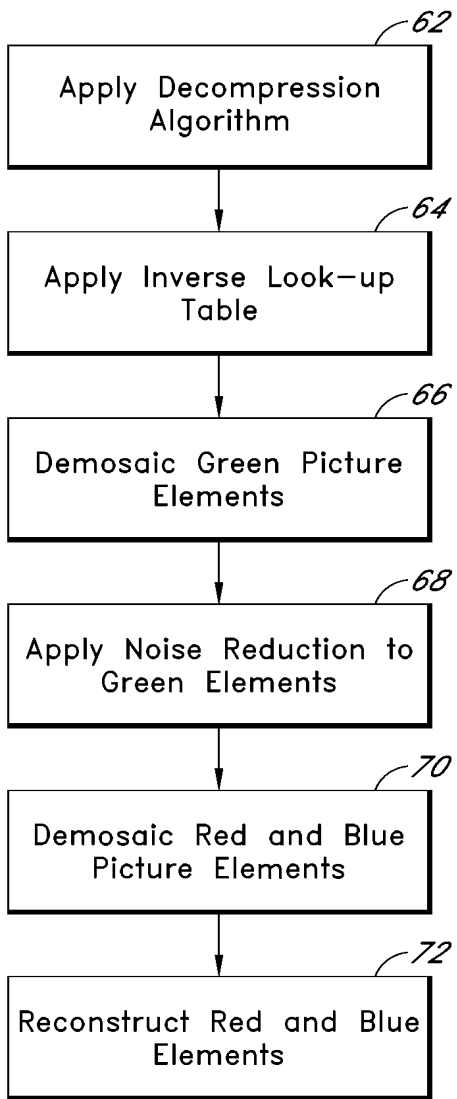

FIG. 12

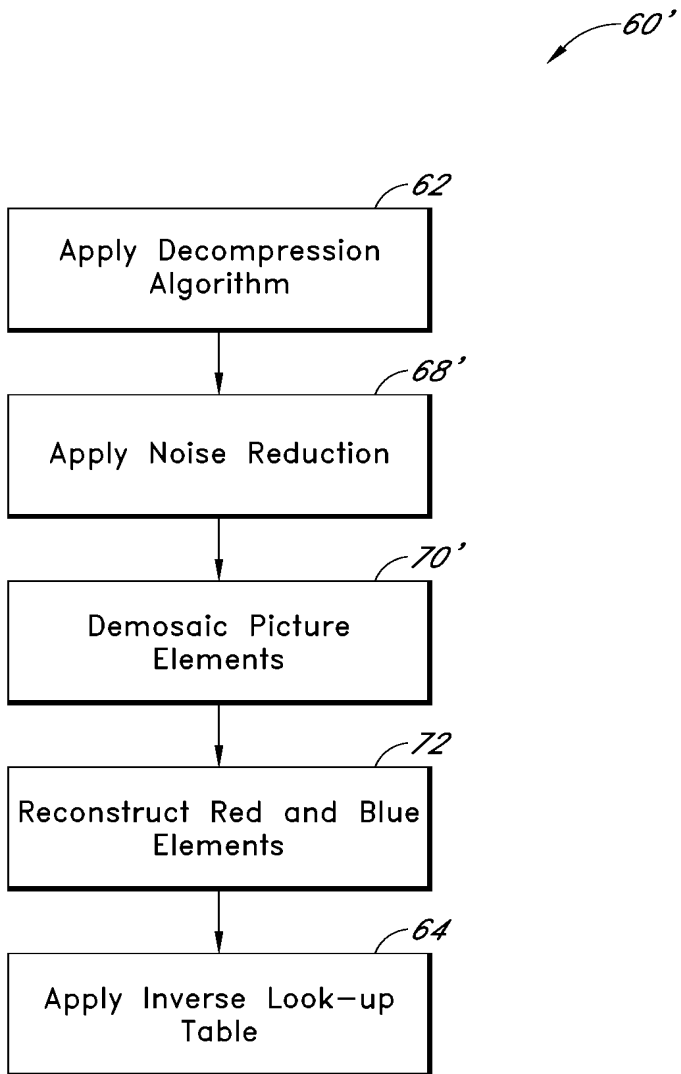

FIG. 12A

	$m-3$	$m-2$	$m-1$	m	$m+1$	$m+2$	$m+3$	$m+4$
$n-3$	$DG_{m-3,n-3}$	$G_{m-2,n-3}$	$DG_{m-1,n-3}$	$G_{m,n-3}$	$DG_{m+1,n-3}$	$G_{m+2,n-3}$	$DG_{m+3,n-3}$	$G_{m+4,n-3}$
$n-2$	$G_{m-3,n-2}$	$DG_{m-2,n-2}$	$G_{m-1,n-2}$	$DG_{m,n-2}$	$G_{m+1,n-2}$	$DG_{m+2,n-2}$	$G_{m+3,n-2}$	$DG_{m+4,n-2}$
$n-1$	$DG_{m-3,n-1}$	$G_{m-2,n-1}$	$DG_{m-1,n-1}$	$G_{m,n-1}$	$DG_{m+1,n-1}$	$G_{m+2,n-1}$	$DG_{m+3,n-1}$	$G_{m+4,n-1}$
n	$G_{m-3,n}$	$DG_{m-2,n}$	$G_{m-1,n}$	$DG_{m,n}$	$G_{m+1,n}$	$DG_{m+2,n}$	$G_{m+3,n}$	$DG_{m+4,n}$
$n+1$	$DG_{m-3,n+1}$	$G_{m-2,n+1}$	$DG_{m-1,n+1}$	$G_{m,n+1}$	$DG_{m+1,n+1}$	$G_{m+2,n+1}$	$DG_{m+3,n+1}$	$G_{m+4,n+1}$
$n+2$	$G_{m-3,n+2}$	$DG_{m-2,n+2}$	$G_{m-1,n+2}$	$DG_{m,n+2}$	$G_{m+1,n+2}$	$DG_{m+2,n+2}$	$G_{m+3,n+2}$	$DG_{m+4,n+2}$
$n+3$	$DG_{m-3,n+3}$	$G_{m-2,n+3}$	$DG_{m-1,n+3}$	$G_{m,n+3}$	$DG_{m+1,n+3}$	$G_{m+2,n+3}$	$DG_{m+3,n+3}$	$G_{m+4,n+3}$
$n+4$	$G_{m-3,n+4}$	$DG_{m-2,n+4}$	$G_{m-1,n+4}$	$DG_{m,n+4}$	$G_{m+1,n+4}$	$DG_{m+2,n+4}$	$G_{m+3,n+4}$	$DG_{m+4,n+4}$

FIG. 13

	$m-3$	$m-2$	$m-1$	m	$m+1$	$m+2$	$m+3$	$m+4$
$n-3$	$DG_{m-3,n-3}$	$DG_{m-2,n-3}$	$DG_{m-1,n-3}$	$DG_{m,n-3}$	$DG_{m+1,n-3}$	$DG_{m+2,n-3}$	$DG_{m+3,n-3}$	$DG_{m+4,n-3}$
$n-2$	$G_{m-3,n-2}$	$DG_{m-2,n-2}$	$G_{m-1,n-2}$	$DG_{m,n-2}$	$G_{m+1,n-2}$	$DG_{m+2,n-2}$	$G_{m+3,n-2}$	$DG_{m+4,n-2}$
$n-1$	$DG_{m-3,n-1}$	$DG_{m-2,n-1}$	$DG_{m-1,n-1}$	$DG_{m,n-1}$	$DG_{m+1,n-1}$	$DG_{m+2,n-1}$	$DG_{m+3,n-1}$	$DG_{m+4,n-1}$
n	$G_{m-3,n}$	$DG_{m-2,n}$	$G_{m-1,n}$	$DG_{m,n}$	$G_{m+1,n}$	$DG_{m+2,n}$	$G_{m+3,n}$	$DG_{m+4,n}$
$n+1$	$DG_{m-3,n+1}$	$DG_{m-2,n+1}$	$DG_{m-1,n+1}$	$DG_{m,n+1}$	$DG_{m+1,n+1}$	$DG_{m+2,n+1}$	$DG_{m+3,n+1}$	$DG_{m+4,n+1}$
$n+2$	$G_{m-3,n+2}$	$DG_{m-2,n+2}$	$G_{m-1,n+2}$	$DG_{m,n+2}$	$G_{m+1,n+2}$	$DG_{m+2,n+2}$	$G_{m+3,n+2}$	$DG_{m+4,n+2}$
$n+3$	$DG_{m-3,n+3}$	$DG_{m-2,n+3}$	$DG_{m-1,n+3}$	$DG_{m,n+3}$	$DG_{m+1,n+3}$	$DG_{m+2,n+3}$	$DG_{m+3,n+3}$	$DG_{m+4,n+3}$
$n+4$	$G_{m-3,n+4}$	$DG_{m-2,n+4}$	$G_{m-1,n+4}$	$DG_{m,n+4}$	$G_{m+1,n+4}$	$DG_{m+2,n+4}$	$G_{m+3,n+4}$	$DG_{m+4,n+4}$

FIG. 14

$m-3$	$B_{m-3,n-3}$		$B_{m-3,n-1}$		$B_{m-3,n+1}$		$B_{m-3,n+3}$	
$m-2$								
$m-1$	$B_{m-1,n-3}$		$B_{m-1,n-1}$		$B_{m-1,n+1}$		$B_{m-1,n+3}$	
m								
$m+1$	$B_{m+1,n-3}$		$B_{m+1,n-1}$		$B_{m+1,n+1}$		$B_{m+1,n+3}$	
$m+2$								
$m+3$	$B_{m+3,n-3}$		$B_{m+3,n-1}$		$B_{m+3,n+1}$		$B_{m+3,n+3}$	
$m+4$								
$n-3$								
$n-2$								
$n-1$								
n								
$n+1$								
$n+2$								
$n+3$								
$n+4$								

FIG. 15

	$m-3$	$m-2$	$m-1$	m	$m+1$	$m+2$	$m+3$	$m+4$
$n-3$	$B_{m-3,n-3}$	$DB_{m-2,n-3}$	$B_{m-1,n-3}$	$DB_{m,n-3}$	$B_{m+1,n-3}$	$DB_{m+2,n-3}$	$B_{m+3,n-3}$	$DB_{m+4,n-3}$
$n-2$	$DB_{m-3,n-2}$	$DB_{m-2,n-2}$	$DB_{m-1,n-2}$	$DB_{m,n-2}$	$DB_{m+1,n-2}$	$DB_{m+2,n-2}$	$DB_{m+3,n-2}$	$DB_{m+4,n-2}$
$n-1$	$B_{m+3,n-1}$	$DB_{m-2,n-1}$	$B_{m-1,n-1}$	$DB_{m,n-1}$	$B_{m+1,n-1}$	$DB_{m+2,n-1}$	$B_{m+3,n-1}$	$DB_{m+4,n-1}$
n	$DB_{m-3,n}$	$DB_{m-2,n}$	$DB_{m-1,n}$	$DB_{m,n}$	$DB_{m+1,n}$	$DB_{m+2,n}$	$DB_{m+3,n}$	$DB_{m+4,n}$
$n+1$	$B_{m-3,n+1}$	$DB_{m-2,n+1}$	$B_{m-1,n+1}$	$DB_{m,n+1}$	$B_{m+1,n+1}$	$DB_{m+2,n+1}$	$B_{m+3,n+1}$	$DB_{m+4,n+1}$
$n+2$	$DB_{m-3,n+2}$	$DB_{m-2,n+2}$	$DB_{m-1,n+2}$	$DB_{m,n+2}$	$DB_{m+1,n+2}$	$DB_{m+2,n+2}$	$DB_{m+3,n+2}$	$DB_{m+4,n+2}$
$n+3$	$B_{m-3,n+3}$	$DB_{m-2,n+3}$	$B_{m-1,n+3}$	$DB_{m,n+3}$	$B_{m+1,n+3}$	$DB_{m+2,n+3}$	$B_{m+3,n+3}$	$DB_{m+4,n+3}$
$n+4$	$DB_{m-3,n+4}$	$DB_{m-2,n+4}$	$DB_{m-1,n+4}$	$DB_{m,n+4}$	$DB_{m+1,n+4}$	$DB_{m+2,n+4}$	$DB_{m+3,n+4}$	$DB_{m+4,n+4}$

FIG. 16

Electronic Patent Application Fee Transmittal

Application Number:	
Filing Date:	
Title of Invention:	VIDEO CAMERA
First Named Inventor/Applicant Name:	James H. Jannard
Filer:	Sean Patrick Ambrosius/Jennifer Brown
Attorney Docket Number:	REDCOM.007C4

Filed as Large Entity

Track I Prioritized Examination - Nonprovisional Application under 35 USC 111(a) Filing Fees

Description	Fee Code	Quantity	Amount	Sub-Total in USD(\$)
Basic Filing:				
Utility application filing	1011	1	280	280
Utility Search Fee	1111	1	600	600
Utility Examination Fee	1311	1	720	720
Request for Prioritized Examination	1817	1	4000	4000

Pages:

Claims:

Claims in Excess of 20	1202	10	80	800
------------------------	------	----	----	-----

Miscellaneous-Filing:

Description	Fee Code	Quantity	Amount	Sub-Total in USD(\$)
Publ. Fee- Early, Voluntary, or Normal	1504	1	0	0
PROCESSING FEE, EXCEPT PROV. APPLS.	1830	1	140	140
Petition:				
Patent-Appeals-and-Interference:				
Post-Allowance-and-Post-Issuance:				
Extension-of-Time:				
Miscellaneous:				
Total in USD (\$)				6540

Electronic Acknowledgement Receipt

EFS ID:	20129326
Application Number:	14485612
International Application Number:	
Confirmation Number:	1068
Title of Invention:	VIDEO CAMERA
First Named Inventor/Applicant Name:	James H. Jannard
Customer Number:	20995
Filer:	Sean Patrick Ambrosius/Anthony Bonilla
Filer Authorized By:	Sean Patrick Ambrosius
Attorney Docket Number:	REDCOM.007C4
Receipt Date:	12-SEP-2014
Filing Date:	
Time Stamp:	20:37:18
Application Type:	Utility under 35 USC 111(a)

Payment information:

Submitted with Payment	yes
Payment Type	Credit Card
Payment was successfully received in RAM	\$6540
RAM confirmation Number	5729
Deposit Account	111410
Authorized User	KNOBBE MARTENS OLSON AND BEAR

The Director of the USPTO is hereby authorized to charge indicated fees and credit any overpayment as follows:

Charge any Additional Fees required under 37 C.F.R. Section 1.16 (National application filing, search, and examination fees)

Charge any Additional Fees required under 37 C.F.R. Section 1.17 (Patent application and reexamination processing fees)

File Listing:					
Document Number	Document Description	File Name	File Size(Bytes)/ Message Digest	Multi Part /.zip	Pages (if appl.)
1	TrackOne Request	REDCOM-007C4_PrioritizedExamRequest.pdf	74223 5a7162298bd63ccd6a3d9b4f421d31d9b4c9c01	no	1
Warnings:					
Information:					
2	Application Data Sheet	REDCOM-007C4_ADS.pdf	1561742 dc448b1eea3bb27aa166357365ba40d23a2b2d03	no	7
Warnings:					
Information:					
3	Miscellaneous Incoming Letter	REDCOM-007C4_Rescission.pdf	16053 904eb3e191ab76d126428ee6dfd78c5e2d0b333b	no	1
Warnings:					
Information:					
4		REDCOM-007C4_Spec.pdf	152067 75688d0c9b45f2530fa29770a09be9c60e3585ee	yes	31
	Multipart Description/PDF files in .zip description				
	Document Description		Start	End	
	Specification		1	23	
	Claims		24	30	
Abstract		31	31		
Warnings:					
Information:					
5	Power of Attorney	REDCOM-007C4_POA.pdf	436653 0ed0d3bc468810a5c3b6920b8d1e3f877d90d429	no	2
Warnings:					
Information:					
6	Drawings-only black and white line drawings	REDCOM-007C4_Figs.pdf	1475246 0df52a29162fabe588c8bf7cd11dfc212c68f254	no	18
Warnings:					
Information:					
7	Fee Worksheet (SB06)	fee-info.pdf	41835 50d30aa29d8025d505a723c94bab87fb60c7833f	no	2

Warnings:	
Information:	
Total Files Size (in bytes):	3757819
<p>This Acknowledgement Receipt evidences receipt on the noted date by the USPTO of the indicated documents, characterized by the applicant, and including page counts, where applicable. It serves as evidence of receipt similar to a Post Card, as described in MPEP 503.</p> <p><u>New Applications Under 35 U.S.C. 111</u> If a new application is being filed and the application includes the necessary components for a filing date (see 37 CFR 1.53(b)-(d) and MPEP 506), a Filing Receipt (37 CFR 1.54) will be issued in due course and the date shown on this Acknowledgement Receipt will establish the filing date of the application.</p> <p><u>National Stage of an International Application under 35 U.S.C. 371</u> If a timely submission to enter the national stage of an international application is compliant with the conditions of 35 U.S.C. 371 and other applicable requirements a Form PCT/DO/EO/903 indicating acceptance of the application as a national stage submission under 35 U.S.C. 371 will be issued in addition to the Filing Receipt, in due course.</p> <p><u>New International Application Filed with the USPTO as a Receiving Office</u> If a new international application is being filed and the international application includes the necessary components for an international filing date (see PCT Article 11 and MPEP 1810), a Notification of the International Application Number and of the International Filing Date (Form PCT/RO/105) will be issued in due course, subject to prescriptions concerning national security, and the date shown on this Acknowledgement Receipt will establish the international filing date of the application.</p>	

Electronic Acknowledgement Receipt

EFS ID:	20129326
Application Number:	14485612
International Application Number:	
Confirmation Number:	1068
Title of Invention:	VIDEO CAMERA
First Named Inventor/Applicant Name:	James H. Jannard
Customer Number:	20995
Filer:	Sean Patrick Ambrosius/Anthony Bonilla
Filer Authorized By:	Sean Patrick Ambrosius
Attorney Docket Number:	REDCOM.007C4
Receipt Date:	12-SEP-2014
Filing Date:	
Time Stamp:	20:37:18
Application Type:	Utility under 35 USC 111(a)

Payment information:

Submitted with Payment	yes
Payment Type	Credit Card
Payment was successfully received in RAM	\$6540
RAM confirmation Number	5729
Deposit Account	111410
Authorized User	KNOBBE MARTENS OLSON AND BEAR

The Director of the USPTO is hereby authorized to charge indicated fees and credit any overpayment as follows:

Charge any Additional Fees required under 37 C.F.R. Section 1.16 (National application filing, search, and examination fees)

Charge any Additional Fees required under 37 C.F.R. Section 1.17 (Patent application and reexamination processing fees)

File Listing:					
Document Number	Document Description	File Name	File Size(Bytes)/ Message Digest	Multi Part /.zip	Pages (if appl.)
1	TrackOne Request	REDCOM-007C4_PrioritizedExamRequest.pdf	74223 5a7162298bd63ccd6a3d9b4f421d31d9b64c9c01	no	1
Warnings:					
Information:					
2	Application Data Sheet	REDCOM-007C4_ADS.pdf	1561742 dc448b1eea3bb27aa166357365ba40d23a2b2d03	no	7
Warnings:					
Information:					
3	Miscellaneous Incoming Letter	REDCOM-007C4_Rescission.pdf	16053 904eb3e191ab76d126428ee6dfd78c5e2d0b333b	no	1
Warnings:					
Information:					
4		REDCOM-007C4_Spec.pdf	152067 75688d0c9b45f2530fa29770a09be9c60e3585ee	yes	31
	Multipart Description/PDF files in .zip description				
	Document Description		Start	End	
	Specification		1	23	
	Claims		24	30	
Abstract		31	31		
Warnings:					
Information:					
5	Power of Attorney	REDCOM-007C4_POA.pdf	436653 0ed0d3bc468810a5c3b6920b8d1e3f877d90d429	no	2
Warnings:					
Information:					
6	Drawings-only black and white line drawings	REDCOM-007C4_Figs.pdf	1475246 0df52a29162fabe588c8bf7cd11dfc212c68f254	no	18
Warnings:					
Information:					
7	Fee Worksheet (SB06)	fee-info.pdf	41835 50d30aa29d8025d505a723c94bab87fb60c7833f	no	2

Warnings:	
Information:	
Total Files Size (in bytes):	3757819
<p>This Acknowledgement Receipt evidences receipt on the noted date by the USPTO of the indicated documents, characterized by the applicant, and including page counts, where applicable. It serves as evidence of receipt similar to a Post Card, as described in MPEP 503.</p> <p><u>New Applications Under 35 U.S.C. 111</u> If a new application is being filed and the application includes the necessary components for a filing date (see 37 CFR 1.53(b)-(d) and MPEP 506), a Filing Receipt (37 CFR 1.54) will be issued in due course and the date shown on this Acknowledgement Receipt will establish the filing date of the application.</p> <p><u>National Stage of an International Application under 35 U.S.C. 371</u> If a timely submission to enter the national stage of an international application is compliant with the conditions of 35 U.S.C. 371 and other applicable requirements a Form PCT/DO/EO/903 indicating acceptance of the application as a national stage submission under 35 U.S.C. 371 will be issued in addition to the Filing Receipt, in due course.</p> <p><u>New International Application Filed with the USPTO as a Receiving Office</u> If a new international application is being filed and the international application includes the necessary components for an international filing date (see PCT Article 11 and MPEP 1810), a Notification of the International Application Number and of the International Filing Date (Form PCT/RO/105) will be issued in due course, subject to prescriptions concerning national security, and the date shown on this Acknowledgement Receipt will establish the international filing date of the application.</p>	

**CERTIFICATION AND REQUEST FOR PRIORITIZED EXAMINATION
 UNDER 37 CFR 1.102(e) (Page 1 of 1)**

First Named Inventor:	James H. Jannard et al.	Nonprovisional Application Number (if known):	Unknown
Title of Invention:	VIDEO CAMERA		

APPLICANT HEREBY CERTIFIES THE FOLLOWING AND REQUESTS PRIORITIZED EXAMINATION FOR THE ABOVE-IDENTIFIED APPLICATION.

1. The processing fee set forth in 37 CFR 1.17(i)(1) and the prioritized examination fee set forth in 37 CFR 1.17(c) have been filed with the request. The publication fee requirement is met because that fee, set forth in 37 CFR 1.18(d), is currently \$0. The basic filing fee, search fee, and examination fee are filed with the request or have been already been paid. I understand that any required excess claims fees or application size fee must be paid for the application.
2. I understand that the application may not contain, or be amended to contain, more than four independent claims, more than thirty total claims, or any multiple dependent claims, and that any request for an extension of time will cause an outstanding Track I request to be dismissed.
3. The applicable box is checked below:
 - I. **Original Application (Track One) - Prioritized Examination under § 1.102(e)(1)**
 - i. (a) The application is an original nonprovisional utility application filed under 35 U.S.C. 111(a). This certification and request is being filed with the utility application via EFS-Web.
 ---OR---
 - (b) The application is an original nonprovisional plant application filed under 35 U.S.C. 111(a). This certification and request is being filed with the plant application in paper.
 - ii. An executed inventor's oath or declaration under 37 CFR 1.63 or 37 CFR 1.64 for each inventor, or the application data sheet meeting the conditions specified in 37 CFR 1.53(f)(3)(i) is filed with the application.
 - II. **Request for Continued Examination - Prioritized Examination under § 1.102(e)(2)**
 - i. A request for continued examination has been filed with, or prior to, this form.
 - ii. If the application is a utility application, this certification and request is being filed via EFS-Web.
 - iii. The application is an original nonprovisional utility application filed under 35 U.S.C. 111(a), or is a national stage entry under 35 U.S.C. 371.
 - iv. This certification and request is being filed prior to the mailing of a first Office action responsive to the request for continued examination.
 - v. No prior request for continued examination has been granted prioritized examination status under 37 CFR 1.102(e)(2).

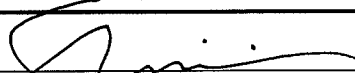
Signature		Date	9/12/2014
Name (Print/Typed)	Sean Ambrosius	Practitioner Registration Number	65,290

Note: This form must be signed in accordance with 37 CFR 1.33. See 37 CFR 1.4(d) for signature requirements and certifications. Submit multiple forms if more than one signature is required.*

*Total of 1 forms are submitted.

Under the Paperwork Reduction Act of 1995, no persons are required to respond to a collection of information unless it contains a valid OMB control number.

Application Data Sheet 37 CFR 1.76		Attorney Docket Number	REDCOM.007C4
		Application Number	
Title of Invention	VIDEO CAMERA		
<p>The application data sheet is part of the provisional or nonprovisional application for which it is being submitted. The following form contains the bibliographic data arranged in a format specified by the United States Patent and Trademark Office as outlined in 37 CFR 1.76. This document may be completed electronically and submitted to the Office in electronic format using the Electronic Filing System (EFS) or the document may be printed and included in a paper filed application.</p>			

Secrecy Order 37 CFR 5.2

<input type="checkbox"/>	Portions or all of the application associated with this Application Data Sheet may fall under a Secrecy Order pursuant to 37 CFR 5.2 (Paper filers only. Applications that fall under Secrecy Order may not be filed electronically.)
--------------------------	---

Inventor Information:

Inventor 1					<input type="button" value="Remove"/>
Legal Name					
Prefix	Given Name	Middle Name	Family Name	Suffix	
	James	H.	Jannard		
Residence Information (Select One) <input checked="" type="radio"/> US Residency <input type="radio"/> Non US Residency <input type="radio"/> Active US Military Service					
City	Las Vegas	State/Province	NV	Country of Residence i	US

Mailing Address of Inventor:

Address 1	15 Wild Ridge				
Address 2					
City	Irvine	State/Province	CA		
Postal Code	89135	Country i	US		

Inventor 2					<input type="button" value="Remove"/>
Legal Name					
Prefix	Given Name	Middle Name	Family Name	Suffix	
	Thomas	Graeme	Nattress		
Residence Information (Select One) <input type="radio"/> US Residency <input checked="" type="radio"/> Non US Residency <input type="radio"/> Active US Military Service					
City	Acton	Country of Residence i	CA		

Mailing Address of Inventor:

Address 1	41 Bower St.				
Address 2					
City	Acton	State/Province	ON		
Postal Code	L7J 1E1	Country i	CA		

All Inventors Must Be Listed - Additional Inventor Information blocks may be generated within this form by selecting the **Add** button.

Correspondence Information:

Application Data Sheet 37 CFR 1.76		Attorney Docket Number	REDCOM.007C4
		Application Number	
Title of Invention	VIDEO CAMERA		

Enter either Customer Number or complete the Correspondence Information section below.
For further information see 37 CFR 1.33(a).

An Address is being provided for the correspondence information of this application.

Customer Number	20995		
Email Address	efiling@knobbe.com	<input type="button" value="Add Email"/>	<input type="button" value="Remove Email"/>

Application Information:

Title of the Invention	VIDEO CAMERA		
Attorney Docket Number	REDCOM.007C4	Small Entity Status Claimed	<input type="checkbox"/>
Application Type	Nonprovisional		
Subject Matter	Utility		
Total Number of Drawing Sheets (if any)	18	Suggested Figure for Publication (if any)	

Filing By Reference :

Only complete this section when filing an application by reference under 35 U.S.C. 111(c) and 37 CFR 1.57(a). Do not complete this section if application papers including a specification and any drawings are being filed. Any domestic benefit or foreign priority information must be provided in the appropriate section(s) below (i.e., "Domestic Benefit/National Stage Information" and "Foreign Priority Information").

For the purposes of a filing date under 37 CFR 1.53(b), the description and any drawings of the present application are replaced by this reference to the previously filed application, subject to conditions and requirements of 37 CFR 1.57(a).

Application number of the previously filed application	Filing date (YYYY-MM-DD)	Intellectual Property Authority or Country

Publication Information:

Request Early Publication (Fee required at time of Request 37 CFR 1.219)

Request Not to Publish. I hereby request that the attached application not be published under 35 U.S.C. 122(b) and certify that the invention disclosed in the attached application **has not and will not** be the subject of an application filed in another country, or under a multilateral international agreement, that requires publication at eighteen months after filing.

Representative Information:

Representative information should be provided for all practitioners having a power of attorney in the application. Providing this information in the Application Data Sheet does not constitute a power of attorney in the application (see 37 CFR 1.32). Either enter Customer Number or complete the Representative Name section below. If both sections are completed the customer number will be used for the Representative Information during processing.

Please Select One:	<input checked="" type="radio"/> Customer Number	<input type="radio"/> US Patent Practitioner	<input type="radio"/> Limited Recognition (37 CFR 11.9)
Customer Number	20995		

Application Data Sheet 37 CFR 1.76		Attorney Docket Number	REDCOM.007C4
		Application Number	
Title of Invention	VIDEO CAMERA		

Domestic Benefit/National Stage Information:

This section allows for the applicant to either claim benefit under 35 U.S.C. 119(e), 120, 121, or 365(c) or indicate National Stage entry from a PCT application. Providing this information in the application data sheet constitutes the specific reference required by 35 U.S.C. 119(e) or 120, and 37 CFR 1.78.

When referring to the current application, please leave the application number blank.

Prior Application Status	Pending	<input type="button" value="Remove"/>			
Application Number	Continuity Type	Prior Application Number	Filing Date (YYYY-MM-DD)		
	Continuation of	13/464803	2012-05-04		
Prior Application Status	Patented	<input type="button" value="Remove"/>			
Application Number	Continuity Type	Prior Application Number	Filing Date (YYYY-MM-DD)	Patent Number	Issue Date (YYYY-MM-DD)
13/464803	Continuation of	12/101882	2008-04-11	8174560	2012-05-08
Prior Application Status	Expired	<input type="button" value="Remove"/>			
Application Number	Continuity Type	Prior Application Number	Filing Date (YYYY-MM-DD)		
12/101882	Claims benefit of provisional	60/911196	2007-04-11		
Prior Application Status	Expired	<input type="button" value="Remove"/>			
Application Number	Continuity Type	Prior Application Number	Filing Date (YYYY-MM-DD)		
12/101882	Claims benefit of provisional	61/017406	2007-12-28		
Additional Domestic Benefit/National Stage Data may be generated within this form by selecting the Add button.					<input type="button" value="Add"/>

Foreign Priority Information:

This section allows for the applicant to claim priority to a foreign application. Providing this information in the application data sheet constitutes the claim for priority as required by 35 U.S.C. 119(b) and 37 CFR 1.55(d). When priority is claimed to a foreign application that is eligible for retrieval under the priority document exchange program (PDX) the information will be used by the Office to automatically attempt retrieval pursuant to 37 CFR 1.55(h)(1) and (2). Under the PDX program, applicant bears the ultimate responsibility for ensuring that a copy of the foreign application is received by the Office from the participating foreign intellectual property office, or a certified copy of the foreign priority application is filed, within the time period specified in 37 CFR 1.55(g)(1).

<input type="button" value="Remove"/>				
Application Number	Country ⁱ	Filing Date (YYYY-MM-DD)	Access Code ⁱ (if applicable)	
Additional Foreign Priority Data may be generated within this form by selecting the Add button.				<input type="button" value="Add"/>

Application Data Sheet 37 CFR 1.76		Attorney Docket Number	REDCOM.007C4
		Application Number	
Title of Invention	VIDEO CAMERA		

Statement under 37 CFR 1.55 or 1.78 for AIA (First Inventor to File) Transition Applications

<p>This application (1) claims priority to or the benefit of an application filed before March 16, 2013 and (2) also contains, or contained at any time, a claim to a claimed invention that has an effective filing date on or after March 16, 2013.</p> <p><input type="checkbox"/> NOTE: By providing this statement under 37 CFR 1.55 or 1.78, this application, with a filing date on or after March 16, 2013, will be examined under the first inventor to file provisions of the AIA.</p>
--

Authorization to Permit Access:

<p><input type="checkbox"/> Authorization to Permit Access to the Instant Application by the Participating Offices</p> <p>If checked, the undersigned hereby grants the USPTO authority to provide the European Patent Office (EPO), the Japan Patent Office (JPO), the Korean Intellectual Property Office (KIPO), the World Intellectual Property Office (WIPO), and any other intellectual property offices in which a foreign application claiming priority to the instant patent application is filed access to the instant patent application. See 37 CFR 1.14(c) and (h). This box should not be checked if the applicant does not wish the EPO, JPO, KIPO, WIPO, or other intellectual property office in which a foreign application claiming priority to the instant patent application is filed to have access to the instant patent application.</p> <p>In accordance with 37 CFR 1.14(h)(3), access will be provided to a copy of the instant patent application with respect to: 1) the instant patent application-as-filed; 2) any foreign application to which the instant patent application claims priority under 35 U.S.C. 119(a)-(d) if a copy of the foreign application that satisfies the certified copy requirement of 37 CFR 1.55 has been filed in the instant patent application; and 3) any U.S. application-as-filed from which benefit is sought in the instant patent application.</p> <p>In accordance with 37 CFR 1.14(c), access may be provided to information concerning the date of filing this Authorization.</p>

Applicant Information:

<p>Providing assignment information in this section does not substitute for compliance with any requirement of part 3 of Title 37 of CFR to have an assignment recorded by the Office.</p>
--

Application Data Sheet 37 CFR 1.76	Attorney Docket Number	REDCOM.007C4
	Application Number	
Title of Invention	VIDEO CAMERA	

Applicant 1			<input type="button" value="Remove"/>
<p>If the applicant is the inventor (or the remaining joint inventor or inventors under 37 CFR 1.45), this section should not be completed. The information to be provided in this section is the name and address of the legal representative who is the applicant under 37 CFR 1.43; or the name and address of the assignee, person to whom the inventor is under an obligation to assign the invention, or person who otherwise shows sufficient proprietary interest in the matter who is the applicant under 37 CFR 1.46. If the applicant is an applicant under 37 CFR 1.46 (assignee, person to whom the inventor is obligated to assign, or person who otherwise shows sufficient proprietary interest) together with one or more joint inventors, then the joint inventor or inventors who are also the applicant should be identified in this section.</p>			
<input type="button" value="Clear"/>			
<input checked="" type="radio"/> Assignee	<input type="radio"/> Legal Representative under 35 U.S.C. 117	<input type="radio"/> Joint Inventor	
<input type="radio"/> Person to whom the inventor is obligated to assign.		<input type="radio"/> Person who shows sufficient proprietary interest	
If applicant is the legal representative, indicate the authority to file the patent application, the inventor is:			
Name of the Deceased or Legally Incapacitated Inventor : <input type="text"/>			
If the Applicant is an Organization check here. <input checked="" type="checkbox"/>			
Organization Name	RED.COM, INC.		
Mailing Address Information:			
Address 1	34 Parker		
Address 2			
City	Irvine	State/Province	CA
Country ⁱ	US	Postal Code	92618
Phone Number		Fax Number	
Email Address			
Additional Applicant Data may be generated within this form by selecting the Add button.			<input type="button" value="Add"/>

Assignee Information including Non-Applicant Assignee Information:

<p>Providing assignment information in this section does not substitute for compliance with any requirement of part 3 of Title 37 of CFR to have an assignment recorded by the Office.</p>	
Assignee 1	
<p>Complete this section if assignee information, including non-applicant assignee information, is desired to be included on the patent application publication. An assignee-applicant identified in the "Applicant Information" section will appear on the patent application publication as an applicant. For an assignee-applicant, complete this section only if identification as an assignee is also desired on the patent application publication.</p>	
<input type="button" value="Remove"/>	
If the Assignee or Non-Applicant Assignee is an Organization check here. <input type="checkbox"/>	

Under the Paperwork Reduction Act of 1995, no persons are required to respond to a collection of information unless it contains a valid OMB control number.

Application Data Sheet 37 CFR 1.76		Attorney Docket Number	REDCOM.007C4
		Application Number	
Title of Invention	VIDEO CAMERA		

Prefix	Given Name	Middle Name	Family Name	Suffix

Mailing Address Information For Assignee including Non-Applicant Assignee:

Address 1				
Address 2				
City		State/Province		
Country i		Postal Code		
Phone Number		Fax Number		
Email Address				

Additional Assignee or Non-Applicant Assignee Data may be generated within this form by selecting the Add button.

Signature:

NOTE: This form must be signed in accordance with 37 CFR 1.33. See 37 CFR 1.4 for signature requirements and certifications					
Signature	/Sean Ambrosius/		Date (YYYY-MM-DD)	2014-09-12	
First Name	Sean	Last Name	Ambrosius	Registration Number	65290
Additional Signature may be generated within this form by selecting the Add button.					<input type="button" value="Add"/>

This collection of information is required by 37 CFR 1.76. The information is required to obtain or retain a benefit by the public which is to file (and by the USPTO to process) an application. Confidentiality is governed by 35 U.S.C. 122 and 37 CFR 1.14. This collection is estimated to take 23 minutes to complete, including gathering, preparing, and submitting the completed application data sheet form to the USPTO. Time will vary depending upon the individual case. Any comments on the amount of time you require to complete this form and/or suggestions for reducing this burden, should be sent to the Chief Information Officer, U.S. Patent and Trademark Office, U.S. Department of Commerce, P.O. Box 1450, Alexandria, VA 22313-1450. DO NOT SEND FEES OR COMPLETED FORMS TO THIS ADDRESS. **SEND TO: Commissioner for Patents, P.O. Box 1450, Alexandria, VA 22313-1450.**

Privacy Act Statement

The Privacy Act of 1974 (P.L. 93-579) requires that you be given certain information in connection with your submission of the attached form related to a patent application or patent. Accordingly, pursuant to the requirements of the Act, please be advised that: (1) the general authority for the collection of this information is 35 U.S.C. 2(b)(2); (2) furnishing of the information solicited is voluntary; and (3) the principal purpose for which the information is used by the U.S. Patent and Trademark Office is to process and/or examine your submission related to a patent application or patent. If you do not furnish the requested information, the U.S. Patent and Trademark Office may not be able to process and/or examine your submission, which may result in termination of proceedings or abandonment of the application or expiration of the patent.

The information provided by you in this form will be subject to the following routine uses:

1. The information on this form will be treated confidentially to the extent allowed under the Freedom of Information Act (5 U.S.C. 552) and the Privacy Act (5 U.S.C. 552a). Records from this system of records may be disclosed to the Department of Justice to determine whether the Freedom of Information Act requires disclosure of these records.
2. A record from this system of records may be disclosed, as a routine use, in the course of presenting evidence to a court, magistrate, or administrative tribunal, including disclosures to opposing counsel in the course of settlement negotiations.
3. A record in this system of records may be disclosed, as a routine use, to a Member of Congress submitting a request involving an individual, to whom the record pertains, when the individual has requested assistance from the Member with respect to the subject matter of the record.
4. A record in this system of records may be disclosed, as a routine use, to a contractor of the Agency having need for the information in order to perform a contract. Recipients of information shall be required to comply with the requirements of the Privacy Act of 1974, as amended, pursuant to 5 U.S.C. 552a(m).
5. A record related to an International Application filed under the Patent Cooperation Treaty in this system of records may be disclosed, as a routine use, to the International Bureau of the World Intellectual Property Organization, pursuant to the Patent Cooperation Treaty.
6. A record in this system of records may be disclosed, as a routine use, to another federal agency for purposes of National Security review (35 U.S.C. 181) and for review pursuant to the Atomic Energy Act (42 U.S.C. 218(c)).
7. A record from this system of records may be disclosed, as a routine use, to the Administrator, General Services, or his/her designee, during an inspection of records conducted by GSA as part of that agency's responsibility to recommend improvements in records management practices and programs, under authority of 44 U.S.C. 2904 and 2906. Such disclosure shall be made in accordance with the GSA regulations governing inspection of records for this purpose, and any other relevant (i.e., GSA or Commerce) directive. Such disclosure shall not be used to make determinations about individuals.
8. A record from this system of records may be disclosed, as a routine use, to the public after either publication of the application pursuant to 35 U.S.C. 122(b) or issuance of a patent pursuant to 35 U.S.C. 151. Further, a record may be disclosed, subject to the limitations of 37 CFR 1.14, as a routine use, to the public if the record was filed in an application which became abandoned or in which the proceedings were terminated and which application is referenced by either a published application, an application open to public inspections or an issued patent.
9. A record from this system of records may be disclosed, as a routine use, to a Federal, State, or local law enforcement agency, if the USPTO becomes aware of a violation or potential violation of law or regulation.

Please Direct All Correspondence to Customer Number 20995

RESCISSION OF ANY PRIOR DISCLAIMERS AND REQUEST TO REVISIT ART

Inventor	: James H. Jannard et al.
App. No	: Unknown
Filed	: Herewith
For	: VIDEO CAMERA
Examiner	: Unknown
Art Unit	: Unknown
Conf #	: Unknown

Commissioner for Patents
P.O. Box 1450
Alexandria, VA 22313-1450

Dear Sir:

The claims of the present application are different and possibly broader in scope than the claims pursued in the parent application(s). To the extent any prior amendments or characterizations of the scope of any claim or referenced art could be construed as a disclaimer of any subject matter supported by the present disclosure, Applicant hereby rescinds and retracts such disclaimer. Accordingly, the references previously considered in the parent application(s) may need to be re-visited.

Please charge any additional fees, including any fees for additional extension of time, or credit overpayment to Deposit Account No. 11-1410.

Knobbe, Martens, Olson & Bear, LLP

Respectfully submitted,

Dated: September 12, 2014

/Sean Ambrosius/ _____
Sean Ambrosius
Registration No. 65,290
Attorney of Record
Customer No. 20995
(949) 760-0404

18673862

VIDEO CAMERA**CROSS-REFERENCE TO RELATED APPLICATIONS**

[0001] This application is a continuation of U.S. Patent Application Serial No. 13/464,803, filed on May 4, 2012, entitled “VIDEO CAMERA,” which is a continuation of U.S. Patent Application 12/101,882, filed on April 11, 2008, entitled “VIDEO CAMERA,” which claims benefit under 35 U.S.C. § 119(e) to U.S. Provisional Patent Application Nos. 60/911,196, filed April 11, 2007, and 61/017,406, filed December 28, 2007. The entire contents of each of the foregoing applications are hereby incorporated by reference herein.

BACKGROUNDField of the Inventions

[0002] The present inventions are directed to digital cameras, such as those for capturing still or moving pictures, and more particularly, to digital cameras that compress image data.

Description of the Related Art

[0003] Despite the availability of digital video cameras, the producers of major motion pictures and some television broadcast media continue to rely on film cameras. The film used for such provides video editors with very high resolution images that can be edited by conventional means. More recently, however, such film is often scanned, digitized and digitally edited.

SUMMARY OF THE INVENTIONS

[0004] Although some currently available digital video cameras include high resolution image sensors, and thus output high resolution video, the image processing and compression techniques used on board such cameras are too lossy and thus eliminate too much raw image data to be acceptable in the high end portions of the market noted above. An aspect of at least one of the embodiments disclosed herein includes the realization that video quality that is acceptable for the higher end portions of the markets noted above, such as the major motion picture market, can be satisfied by cameras that can capture and store

raw or substantially raw video data having a resolution of at least about 2k and at a frame rate of at least about 23 frames per second.

[0005] Thus, in accordance with an embodiment, a video camera can comprise a portable housing, and a lens assembly supported by the housing and configured to focus light. A light sensitive device can be configured to convert the focused light into raw image data with a resolution of at least 2k at a frame rate of at least about twenty-three frames per second. The camera can also include a memory device and an image processing system configured to compress and store in the memory device the raw image data at a compression ratio of at least six to one and remain substantially visually lossless, and at a rate of at least about 23 frames per second.

[0006] In accordance with another embodiment, a method of recording a motion video with a camera can comprise guiding light onto a light sensitive device. The method can also include converting the light received by the light sensitive device into raw digital image data at a rate of at least greater than twenty three frames per second, compressing the raw digital image data, and recording the raw image data at a rate of at least about 23 frames per second onto a storage device.

[0007] In accordance with yet another embodiment, a video camera can comprise a lens assembly supported by the housing and configured to focus light and a light sensitive device configured to convert the focused light into a signal of raw image data representing the focused light. The camera can also include a memory device and means for compressing and recording the raw image data at a frame rate of at least about 23 frames per second.

[0008] In accordance with yet another embodiment, a video camera can comprise a portable housing having at least one handle configured to allow a user to manipulate the orientation with respect to at least one degree of movement of the housing during a video recording operation of the camera. A lens assembly can comprise at least one lens supported by the housing and configured to focus light at a plane disposed inside the housing. A light sensitive device can be configured to convert the focused light into raw image data with a horizontal resolution of at least 2k and at a frame rate of at least about twenty three frames per second. A memory device can also be configured to store video image data. An image processing system can be configured to compress and store in the memory device the raw

image data at a compression ratio of at least six to one and remain substantially visually lossless, and at a rate of at least about 23 frames per second.

[0009] Another aspect of at least one of the inventions disclosed herein includes the realization that because the human eye is more sensitive to green wavelengths than any other color, green image data based modification of image data output from an image sensor can be used to enhance compressibility of the data, yet provide a higher quality video image. One such technique can include subtracting the magnitude of green light detected from the magnitudes of red and/or blue light detected prior to compressing the data. This can convert the red and/or blue image data into a more compressible form. For example, in the known processes for converting gamma corrected RGB data to Y'CbCr, the image is "decorrelated", leaving most of the image data in the Y' (a.k.a. "luma"), and as such, the remaining chroma components are more compressible. However, the known techniques for converting to the Y'CbCr format cannot be applied directly to Bayer pattern data because the individual color data is not spatially correlated and Bayer pattern data includes twice as much green image data as blue or red image data. The processes of green image data subtraction, in accordance with some of the embodiments disclosed herein, can be similar to the Y'CbCr conversion noted above in that most of the image data is left in the green image data, leaving the remaining data in a more compressible form.

[0010] Further, the process of green image data subtraction can be reversed, preserving all the original raw data. Thus, the resulting system and method incorporating such a technique can provide lossless or visually lossless and enhanced compressibility of such video image data.

[0011] Thus, in accordance with an embodiment, a video camera can comprise a lens assembly supported by the housing and configured to focus light and a light sensitive device configured to convert the focused light into a raw signal of image data representing at least first, second, and third colors of the focused light. An image processing module can be configured to modify image data of at least one of the first and second colors based on the image data of the third color. Additionally, the video camera can include a memory device and a compression device configured to compress the image data of the first, second, and third colors and to store the compressed image data on the memory device.

[0012] In accordance with another embodiment, a method of processing an image can be provided. The method can include converting an image and into first image data representing a first color, second image data representing a second color, and third image data representing a third color, modifying at least the first image data and the second image data based on the third image data, compressing the third image data and the modified first and second image data, and storing the compressed data.

[0013] In accordance with yet another embodiment, a video camera can comprise a lens assembly supported by the housing and configured to focus light. A light sensitive device can be configured to convert the focused light into a raw signal of image data representing at least first, second, and third colors of the focused light. The camera can also include means for modifying image data of at least one of the first and second colors based on the image data of the third color, a memory device, and a compression device configured to compress the image data of the first, second, and third colors and to store the compressed image data on the memory device.

BRIEF DESCRIPTION OF THE DRAWINGS

[0014] Figure 1 is a block diagram illustrating a system that can include hardware and/or can be configured to perform methods for processing video image data in accordance with an embodiment.

[0015] Figure 2 is an optional embodiment of a housing for the camera schematically illustrated in Figure 1.

[0016] Figure 3 is a schematic layout of an image sensor having a Bayer Pattern Filter that can be used with the system illustrated in Figure 1.

[0017] Figure 4 is a schematic block diagram of an image processing module that can be used in the system illustrated in Figure 1.

[0018] Figure 5 is a schematic layout of the green image data from the green sensor cells of the image sensor of Figure 3.

[0019] Figure 6 is a schematic layout of the remaining green image data of Figure 5 after an optional process of deleting some of the original green image data.

[0020] Figure 7 is a schematic layout of the red, blue, and green image data of Figure 5 organized for processing in the image processing module of Figure 1.

[0021] Figure 8 is a flowchart illustrating an image data transformation technique that can be used with the system illustrated in Figure 1.

[0022] Figure 8A is a flowchart illustrating a modification of the image data transformation technique of Figure 8 that can also be used with the system illustrated in Figure 1.

[0023] Figure 9 is a schematic layout of blue image data resulting from an image transformation process of Figure 8.

[0024] Figure 10 is a schematic layout of red image data resulting from an image transformation process of Figure 8.

[0025] Figure 11 illustrates an exemplary optional transform that can be applied to the image data for gamma correction.

[0026] Figure 12 is a flowchart of a control routine that can be used with the system of Figure 1 to decompress and demosaic image data.

[0027] Figure 12A is a flowchart illustrating a modification of the control routine of Figure 12 that can also be used with the system illustrated in Figure 1.

[0028] Figure 13 is a schematic layout of green image data having been decompressed and demosaiced according to the flowchart of Figure 12.

[0029] Figure 14 is a schematic layout of half of the original green image data from Figure 13, having been decompressed and demosaiced according to the flowchart of Figure 12.

[0030] Figure 15 is a schematic layout of blue image data having been decompressed according to the flowchart of Figure 12.

[0031] Figure 16 is a schematic layout of blue image data of Figure 15 having been demosaiced according to the flowchart of Figure 12.

DETAILED DESCRIPTION OF EMBODIMENTS

[0032] Figure 1 is a schematic diagram of a camera having image sensing, processing, and compression modules, described in the context of a video camera for moving pictures. The embodiments disclosed herein are described in the context of a video camera having a single sensor device with a Bayer pattern filter because these embodiments have particular utility in this context. However, the embodiments and inventions herein can also

be applied to cameras having other types of image sensors (e.g., CMY Bayer as well as other non-Bayer patterns), other numbers of image sensors, operating on different image format types, and being configured for still and/or moving pictures. Thus, it is to be understood that the embodiments disclosed herein are exemplary but nonlimiting embodiments, and thus, the inventions disclosed herein are not limited to the disclosed exemplary embodiments.

[0033] With continued reference to Figure 1, a camera 10 can include a body or housing 12 configured to support a system 14 configured to detect, process, and optionally store and/or replay video image data. For example, the system 14 can include optics hardware 16, an image sensor 18, an image processing module 20, a compression module 22, and a storage device 24. Optionally, the camera 10 can also include a monitor module 26, a playback module 28, and a display 30.

[0034] Figure 2 illustrates a nonlimiting exemplary embodiment of the camera 10. As shown in Figure 2, the optics hardware 16 can be supported by the housing 12 in a manner that leaves it exposed at its outer surface. In some embodiments, the system 14 is supported within the housing 12. For example, the image sensor 18, image processing module 20, and the compression module 22 can be housed within the housing 12. The storage device 24 can be mounted in the housing 12. Additionally, in some embodiments, the storage device 24 can be mounted to an exterior of the housing 12 and connected to the remaining portions of the system 14 through any type of known connector or cable. Additionally, the storage device 24 can be connected to the housing 12 with a flexible cable, thus allowing the storage device 24 to be moved somewhat independently from the housing 12. For example, with such a flexible cable connection, the storage device 24 can be worn on a belt of a user, allowing the total weight of the housing 12 to be reduced. Further, in some embodiments, the housing can include one or more storage devices 24 inside and mounted to its exterior. Additionally, the housing 12 can also support the monitor module 26, and playback module 28. Additionally, in some embodiments, the display 30 can be configured to be mounted to an exterior of the housing 12.

[0035] The optics hardware 16 can be in the form of a lens system having at least one lens configured to focus an incoming image onto the image sensor 18. The optics hardware 16, optionally, can be in the form of a multi-lens system providing variable zoom,

aperture, and focus. Additionally, the optics hardware 16 can be in the form of a lens socket supported by the housing 12 and configured to receive a plurality of different types of lens systems for example, but without limitation, the optics hardware 16 include a socket configured to receive various sizes of lens systems including a 50-100 millimeter (F2.8) zoom lens, an 18-50 millimeter (F2.8) zoom lens, a 300 millimeter (F2.8) lens, 15 millimeter (F2.8) lens, 25 millimeter (F1.9) lens, 35 millimeter (F1.9) lens, 50 millimeter (F1.9) lens, 85 millimeter (F1.9) lens, and/or any other lens. As noted above, the optics hardware 16 can be configured such that despite which lens is attached thereto, images can be focused upon a light-sensitive surface of the image sensor 18.

[0036] The image sensor 18 can be any type of video sensing device, including, for example, but without limitation, CCD, CMOS, vertically-stacked CMOS devices such as the Foveon® sensor, or a multi-sensor array using a prism to divide light between the sensors. In some embodiments, the image sensor 18 can include a CMOS device having about 12 million photocells. However, other size sensors can also be used. In some configurations, camera 10 can be configured to output video at “2k” (e.g., 2048 x 1152 pixels), “4k” (e.g., 4,096 x 2,540 pixels), “4.5k” horizontal resolution or greater resolutions. As used herein, in the terms expressed in the format of xk (such as 2k and 4k noted above), the “x” quantity refers to the approximate horizontal resolution. As such, “4k” resolution corresponds to about 4000 or more horizontal pixels and “2k” corresponds to about 2000 or more pixels. Using currently commercially available hardware, the sensor can be as small as about 0.5 inches (8 mm), but it can be about 1.0 inches, or larger. Additionally, the image sensor 18 can be configured to provide variable resolution by selectively outputting only a predetermined portion of the sensor 18. For example, the sensor 18 and/or the image processing module can be configured to allow a user to identify the resolution of the image data output.

[0037] The camera 10 can also be configured to downsample and subsequently process the output of the sensor 18 to yield video output at 2K, 1080p, 720p, or any other resolution. For example, the image data from the sensor 18 can be “windowed”, thereby reducing the size of the output image and allowing for higher readout speeds. However,

other size sensors can also be used. Additionally, the camera 10 can be configured to upsample the output of the sensor 18 to yield video output at higher resolutions.

[0038] With reference to Figure 1 and 3, in some embodiments, the sensor 18 can include a Bayer pattern filter. As such, the sensor 18, by way of its chipset (not shown) outputs data representing magnitudes of red, green, or blue light detected by individual photocells of the image sensor 18. Figure 3 schematically illustrates the Bayer pattern output of the sensor 18. In some embodiments, for example, as shown in Figure 3, the Bayer pattern filter has twice as many green elements as the number of red elements and the number of blue elements. The chipset of the image sensor 18 can be used to read the charge on each element of the image sensor and thus output a stream of values in the well-known RGB format output.

[0039] With continued reference to Figure 4, the image processing module 20 optionally can be configured to format the data stream from the image sensor 18 in any known manner. In some embodiments, the image processing module 20 can be configured to separate the green, red, and blue image data into three or four separate data compilations. For example, the image processing module 20 can be configured to separate the red data into one red data element, the blue data into one blue data element, and the green data into one green data element. For example, with reference to Figure 4, the image processing module 20 can include a red data processing module 32, a blue data image processing module 34, and a first green image data processing module 36.

[0040] As noted above, however, the Bayer pattern data illustrated in Figure 3, has twice as many green pixels as the other two colors. Figure 5 illustrates a data component with the blue and red data removed, leaving only the original green image data.

[0041] In some embodiments, the camera 10 can be configured to delete or omit some of the green image data. For example, in some embodiments, the image processing module 20 can be configured to delete 1/2 of the green image data so that the total amount of green image data is the same as the amounts of blue and red image data. For example, Figure 6 illustrates the remaining data after the image processing module 20 deletes 1/2 of the green image data. In the illustrated embodiment of Figure 6, the rows n-3, n-1, n+1, and n+3 have been deleted. This is merely one example of the pattern of green image data that can be deleted. Other patterns and other amounts of green image data can also be deleted.

[0042] In some alternatives, the camera 10 can be configured to delete ½ of the green image data after the red and blue image data has been transformed based on the green image data. This optional technique is described below following the description of the subtraction of green image data values from the other color image data.

[0043] Optionally, the image processing module 20 can be configured to selectively delete green image data. For example, the image processing module 20 can include a deletion analysis module (not shown) configured to selectively determine which green image data to delete. For example, such a deletion module can be configured to determine if deleting a pattern of rows from the green image data would result in aliasing artifacts, such as Moiré lines, or other visually perceptible artifacts. The deletion module can be further configured to choose a pattern of green image data to delete that would present less risk of creating such artifacts. For example, the deletion module can be configured to choose a green image data deletion pattern of alternating vertical columns if it determines that the image captured by the image sensor 18 includes an image feature characterized by a plurality of parallel horizontal lines. This deletion pattern can reduce or eliminate artifacts, such as Moiré lines, that might have resulted from a deletion pattern of alternating lines of image data parallel to the horizontal lines detected in the image.

[0044] However, this merely one exemplary, non-limiting example of the types of image features and deletion patterns that can be used by the deletion module. The deletion module can also be configured to detect other image features and to use other image data deletion patterns, such as for example, but without limitation, deletion of alternating rows, alternating diagonal lines, or other patterns. Additionally, the deletion module can be configured to delete portions of the other image data, such as the red and blue image data, or other image data depending on the type of sensor used.

[0045] Additionally, the camera 10 can be configured to insert a data field into the image data indicating what image data has been deleted. For example, but without limitation, the camera 10 can be configured to insert a data field into the beginning of any video clip stored into the storage device 24, indicating what data has been deleted in each of the “frames” of the video clip. In some embodiments, the camera can be configured to insert a data field into each frame captured by the sensor 18, indicating what image data has been

deleted. For example, in some embodiments, where the image processing module 20 is configured to delete $\frac{1}{2}$ of the green image data in one deletion pattern, the data field can be as small as a single bit data field, indicating whether or not image data has been deleted. Since the image processing module 20 is configured to delete data in only one pattern, a single bit is sufficient to indicate what data has been deleted.

[0046] In some embodiments, as noted above, the image processing module 20 can be configured to selectively delete image data in more than one pattern. Thus, the image data deletion field can be larger, including a sufficient number of values to provide an indication of which of the plurality of different image data deletion patterns was used. This data field can be used by downstream components and or processes to determine to which spatial positions the remaining image data corresponds.

[0047] In some embodiments, the image processing module can be configured to retain all of the raw green image data, e.g., the data shown in Figure 5. In such embodiments, the image processing module can include one or more green image data processing modules.

[0048] As noted above, in known Bayer pattern filters, there are twice as many green elements as the number of red elements and the number of blue elements. In other words, the red elements comprise 25% of the total Bayer pattern array, the blue elements corresponded 25% of the Bayer pattern array and the green elements comprise 50% of the elements of the Bayer pattern array. Thus, in some embodiments, where all of the green image data is retained, the image processing module 20 can include a second green data image processing module 38. As such, the first green data image processing module 36 can process half of the green elements and the second green image data processing module 38 can process the remaining green elements. However, the present inventions can be used in conjunction with other types of patterns, such as for example, but without limitation, CMY and RGBW.

[0049] Figure 7 includes schematic illustrations of the red, blue and two green data components processed by modules 32, 34, 36, and 38 (Figure 4). This can provide further advantages because the size and configuration of each of these modules can be about the same since they are handling about the same amount of data. Additionally, the image processing module 20 can be selectively switched between modes in which is processes all of

the green image data (by using both modules 36 and 38) and modes where ½ of the green image data is deleted (in which it utilizes only one of modules 36 and 38). However, other configurations can also be used.

[0050] Additionally, in some embodiments, the image processing module 20 can include other modules and/or can be configured to perform other processes, such as, for example, but without limitation, gamma correction processes, noise filtering processes, etc.

[0051] Additionally, in some embodiments, the image processing module 20 can be configured to subtract a value of a green element from a value of a blue element and/or red element. As such, in some embodiments, when certain colors are detected by the image sensor 18, the corresponding red or blue element can be reduced to zero. For example, in many photographs, there can be large areas of black, white, or gray, or a color shifted from gray toward the red or blue colors. Thus, if the corresponding pixels of the image sensor 18 have sensed an area of gray, the magnitude of the green, red, and blue, would be about equal. Thus, if the green value is subtracted from the red and blue values, the red and blue values will drop to zero or near zero. Thus, in a subsequent compression process, there will be more zeros generated in pixels that sense a black, white, or gray area and thus the resulting data will be more compressible. Additionally, the subtraction of green from one or both of the other colors can make the resulting image data more compressible for other reasons.

[0052] Such a technique can help achieve a higher effective compression ratio and yet remain visually lossless due to its relationship to the entropy of the original image data. For example, the entropy of an image is related to the amount of randomness in the image. The subtraction of image data of one color, for example, from image data of the other colors can reduce the randomness, and thus reduce the entropy of the image data of those colors, thereby allowing the data to be compressed at higher compression ratios with less loss. Typically, an image is not a collection of random color values. Rather, there is often a certain degree of correlation between surrounding picture elements. Thus, such a subtraction technique can use the correlation of picture elements to achieve better compression. The amount of compression will depend, at least in part, on the entropy of the original information in the image.

[0053] In some embodiments, the magnitudes subtracted from a red or blue pixel can be the magnitude of the value output from a green pixel adjacent to the subject red or blue pixel. Further, in some embodiments, the green magnitude subtracted from the red or blue elements can be derived from an average of the surrounding green elements. Such techniques are described in greater detail below. However, other techniques can also be used.

[0054] Optionally, the image processing module 20 can also be configured to selectively subtract green image data from the other colors. For example, the image processing module 20 can be configured to determine if subtracting green image data from a portion of the image data of either of the other colors would provide better compressibility or not. In this mode, the image processing module 20 can be configured to insert flags into the image data indicating what portions of the image data has been modified (by e.g., green image data subtraction) and which portions have not been so modified. With such flags, a downstream demosaicing/reconstruction component can selectively add green image values back into the image data of the other colors, based on the status of such data flags.

[0055] Optionally, image processing module 20 can also include a further data reduction module (not shown) configured to round values of the red and blue data. For example, if, after the subtraction of green magnitudes, the red or blue data is near zero (e.g., within one or two on an 8-bit scale ranging from 0-255 or higher magnitudes for a higher resolution system). For example, the sensor 18 can be a 12-bit sensor outputting red, blue, and green data on a scale of 0-4095. Any rounding or filtering of the data performed the rounding module can be adjusted to achieve the desired effect. For example, rounding can be performed to a lesser extent if it is desired to have lossless output and to a greater extent if some loss or lossy output is acceptable. Some rounding can be performed and still result in a visually lossless output. For example, on a 8-bit scale, red or blue data having absolute value of up to 2 or 3 can be rounded to 0 and still provide a visually lossless output. Additionally, on a 12-bit scale, red or blue data having an absolute value of up to 10 to 20 can be rounded to 0 and still provide visually lossless output.

[0056] Additionally, the magnitudes of values that can be rounded to zero, or rounded to other values, and still provide a visually lossless output depends on the configuration of the system, including the optics hardware 16, the image sensor 18, the

resolution of the image sensor, the color resolution (bit) of the image sensor 18, the types of filtering, anti-aliasing techniques or other techniques performed by the image processing module 20, the compression techniques performed by the compression module 22, and/or other parameters or characteristics of the camera 10.

[0057] As noted above, in some embodiments, the camera 10 can be configured to delete $\frac{1}{2}$ of the green image data after the red and blue image data has been transformed based on the green image data. For example, but without limitation, the processor module 20 can be configured to delete $\frac{1}{2}$ of the green image data after the average of the magnitudes of the surrounding green data values have been subtracted from the red and blue data values. This reduction in the green data can reduce throughput requirements on the associated hardware. Additionally, the remaining green image data can be used to reconstruct the red and blue image data, described in greater detail below with reference to Figures 14 and 16.

[0058] As noted above, the camera 10 can also include a compression module 22. The compression module 22 can be in the form of a separate chip or it can be implemented with software and another processor. For example, the compression module 22 can be in the form of a commercially available compression chip that performs a compression technique in accordance with the JPEG 2000 standard, or other compression techniques.

[0059] The compression module can be configured to perform any type of compression process on the data from the image processing module 20. In some embodiments, the compression module 22 performs a compression technique that takes advantage of the techniques performed by the image processing module 20. For example, as noted above, the image processing module 20 can be configured to reduce the magnitude of the values of the red and blue data by subtracting the magnitudes of green image data, thereby resulting in a greater number of zero values, as well as other effects. Additionally, the image processing module 20 can perform a manipulation of raw data that uses the entropy of the image data. Thus, the compression technique performed by the compression module 22 can be of a type that benefits from the presence of larger strings of zeros to reduce the size of the compressed data output therefrom.

[0060] Further, the compression module 22 can be configured to compress the image data from the image processing module 20 to result in a visually lossless output. For

example, firstly, the compression module can be configured to apply any known compression technique, such as, but without limitation, JPEG 2000, MotionJPEG, any DCT based codec, any codec designed for compressing RGB image data, H.264, MPEG4, Huffman, or other techniques.

[0061] Depending on the type of compression technique used, the various parameters of the compression technique can be set to provide a visually lossless output. For example, many of the compression techniques noted above can be adjusted to different compression rates, wherein when decompressed, the resulting image is better quality for lower compression rates and lower quality for higher compression rates. Thus, the compression module can be configured to compress the image data in a way that provides a visually lossless output, or can be configured to allow a user to adjust various parameters to obtain a visually lossless output. For example, the compression module 22 can be configured to compress the image data at a compression ratio of about 6:1, 7:1, 8:1 or greater. In some embodiments, the compression module 22 can be configured to compress the image data to a ratio of 12:1 or higher.

[0062] Additionally, the compression module 22 can be configured to allow a user to adjust the compression ratio achieved by the compression module 22. For example, the camera 10 can include a user interface that allows a user to input commands that cause the compression module 22 to change the compression ratio. Thus, in some embodiments, the camera 10 can provide for variable compression.

[0063] As used herein, the term “visually lossless” is intended to include output that, when compared side by side with original (never compressed) image data on the same display device, one of ordinary skill in the art would not be able to determine which image is the original with a reasonable degree of accuracy, based only on a visual inspection of the images.

[0064] With continued reference to Figure 1, the camera 10 can also include a storage device 24. The storage device can be in the form of any type of digital storage, such as, for example, but without limitation, hard disks, flash memory, or any other type of memory device. In some embodiments, the size of the storage device 24 can be sufficiently large to store image data from the compression module 22 corresponding to at least about 30

minutes of video at 12 mega pixel resolution, 12-bit color resolution, and at 60 frames per second. However, the storage device 24 can have any size.

[0065] In some embodiments, the storage device 24 can be mounted on an exterior of the housing 12. Further, in some embodiments, the storage device 24 can be connected to the other components of the system 14 through standard communication ports, including, for example, but without limitation, IEEE 1394, USB 2.0, IDE, SATA, etc. Further, in some embodiments, the storage device 24 can comprise a plurality of hard drives operating under a RAID protocol. However, any type of storage device can be used.

[0066] With continued reference to Figure 1, as noted above, in some embodiments, the system can include a monitor module 26 and a display device 30 configured to allow a user to view video images captured by the image sensor 18 during operation. In some embodiments, the image processing module 20 can include a subsampling system configured to output reduced resolution image data to the monitor module 26. For example, such a subsampling system can be configured to output video image data to support 2K, 1080p, 720p, or any other resolution. In some embodiments, filters used for demosaicing can be adapted to also perform downsampling filtering, such that downsampling and filtering can be performed at the same time. The monitor module 26 can be configured to perform any type of demosaicing process to the data from the image processing module 20. Thereafter, the monitor module 26 can output a demosaiced image data to the display 30.

[0067] The display 30 can be any type of monitoring device. For example, but without limitation, the display 30 can be a four-inch LCD panel supported by the housing 12. For example, in some embodiments, the display 30 can be connected to an infinitely adjustable mount configured to allow the display 30 to be adjusted to any position relative to the housing 12 so that a user can view the display 30 at any angle relative to the housing 12. In some embodiments, the display 30 can be connected to the monitor module through any type of video cables such as, for example, an RGB or YCC format video cable.

[0068] Optionally, the playback module 28 can be configured to receive data from the storage device 24, decompressed and demosaic the image data and then output the image data to the display 30. In some embodiments, the monitor module 26 and the playback

module 28 can be connected to the display through an intermediary display controller (not shown). As such, the display 30 can be connected with a single connector to the display controller. The display controller can be configured to transfer data from either the monitor module 26 or the playback module 28 to the display 30.

[0069] Figure 8 includes a flowchart 50 illustrating the processing of image data by the camera 10. In some embodiments, the flowchart 50 can represent a control routine stored in a memory device, such as the storage device 24, or another storage device (not shown) within the camera 10. Additionally, a central processing unit (CPU) (not shown) can be configured to execute the control routine. The below description of the methods corresponding to the flow chart 50 are described in the context of the processing of a single frame of video image data. Thus, the techniques can be applied to the processing of a single still image. These processes can also be applied to the processing of continuous video, e.g., frame rates of greater than 12, as well as frame rates of 20, 23.976, 24, 30, 60, and 120, or other frame rates between these frame rates or greater.

[0070] With continued reference to Figure 8, control routine can begin at operation block 52. In the operation block 52, the camera 10 can obtain sensor data. For example, with reference to Figure 1, the image sensor 18, which can include a Bayer Sensor and chipset, can output image data.

[0071] For example, but without limitation, with reference to Figure 3, the image sensor can comprise a CMOS device having a Bayer pattern filter on its light receiving surface. Thus, the focused image from the optics hardware 16 is focused on the Bayer pattern filter on the CMOS device of the image sensor 18. Figure 3 illustrates an example of the Bayer pattern created by the arrangement of Bayer pattern filter on the CMOS device.

[0072] In Figure 3, column m is the fourth column from the left edge of the Bayer pattern and row n is the fourth row from the top of the pattern. The remaining columns and rows are labeled relative to column m and row n. However, this layout is merely chosen arbitrarily for purposes of illustration, and does not limit any of the embodiments or inventions disclosed herein.

[0073] As noted above, known Bayer pattern filters often include twice as many green elements as blue and red elements. In the pattern of figure 5, blue elements only appear

in rows $n-3$, $n-1$, $n+1$, and $n+3$. Red elements only appear in rows $n-2$, n , $n+2$, and $n+4$. However, green elements appear in all rows and columns, interspersed with the red and blue elements.

[0074] Thus, in the operation block 52, the red, blue, and green image data output from the image sensor 18 can be received by the image processing module 20 and organized into separate color data components, such as those illustrated in Figure 7. As shown in Figure 7, and as described above with reference to Figure 4, the image processing module 20 can separate the red, blue, and green image data into four separate components. Figure 7 illustrates two green components (Green 1 and Green 2), a blue component, and a red component. However, this is merely one exemplary way of processing image data from the image sensor 18. Additionally, as noted above, the image processing module 20, optionally, can arbitrarily or selectively delete $\frac{1}{2}$ of the green image data.

[0075] After the operation block 52, the flowchart 50 can move on to operation block 54. In the operation block 54, the image data can be further processed. For example, optionally, any one or all of the resulting data (e.g., green 1, green 2, the blue image data from Figure 9, and the red image data from Figure 10) can be further processed.

[0076] For example, the image data can be pre-emphasized or processed in other ways. In some embodiments, the image data can be processed to be more (mathematically) non-linear. Some compression algorithms benefit from performing such a linearization on the picture elements prior to compression. However, other techniques can also be used. For example, the image data can be processed with a linear curve, which provides essentially no emphasis.

[0077] In some embodiments, the operation block 54 can process the image data using curve defined by the function $y=x^{0.5}$. In some embodiments, this curve can be used where the image data was, for example but without limitation, floating point data in the normalized 0-1 range. In other embodiments, for example, where the image data is 12-bit data, the image can be processed with the curve $y=(x/4095)^{0.5}$. Additionally, the image data can be processed with other curves, such as $y=(x+c)^g$ where $0.01 < g < 1$ and c is an offset, which can be 0 in some embodiments. Additionally, log curves can also be used. For example, curves in the form $y=A*\log(B*x+C)$ where A , B , and C are constants chosen to

provide the desired results. Additionally, the above curves and processes can be modified to provide more linear areas in the vicinity of black, similar to those techniques utilized in the well-known Rec709 gamma curve. In applying these processes to the image data, the same processes can be applied to all of the image data, or different processes can be applied to the different colors of image data. However, these are merely exemplary curves that can be used to process the image data, or curves or transforms can also be used. Additionally, these processing techniques can be applied using mathematical functions such as those noted above, or with Look Up Tables (LUTs). Additionally, different processes, techniques, or transforms can be used for different types of image data, different ISO settings used during recording of the image data, temperature (which can affect noise levels), etc.

[0078] After the operation block 54, the flowchart 50 can move to an operation block 56. In the operation block 56, the red and blue picture elements can be transformed. For example, as noted above, green image data can be subtracted from each of the blue and red image data components. In some embodiments, a red or blue image data value can be transformed by subtracting a green image data value of at least one of the green picture elements adjacent to the red or blue picture element. In some embodiments, an average value of the data values of a plurality of adjacent green picture elements can be subtracted from the red or blue image data value. For example, but without limitation, average values of 2, 3, 4, or more green image data values can be calculated and subtracted from red or blue picture elements in the vicinity of the green picture elements.

[0079] For example, but without limitation, with reference to Figure 3, the raw output for the red element $R_{m-2,n-2}$ is surrounded by four green picture elements $G_{m-2,n-3}$, $G_{m-1,n-2}$, $G_{m-3,n-2}$, and $G_{m-2,n-1}$. Thus, the red element $R_{m-2,n-2}$ can be transformed by subtracting the average of the values of the surrounding green element as follows:

[0080] (1) $R_{m,n} = R_{m,n} - (G_{m,n-1} + G_{m+1,n} + G_{m,n+1} + G_{m-1,n})/4$

[0081] Similarly, the blue elements can be transformed in a similar manner by subtracting the average of the surrounding green elements as follows:

[0082] (2) $B_{m+1,n+1} = B_{m+1,n+1} - (G_{m+1,n} + G_{m+2,n+1} + G_{m+1,n+2} + G_{m,n+1})/4$

[0083] Figure 9 illustrates a resulting blue data component where the original blue raw data $B_{m-1,n-1}$ is transformed, the new value labeled as $B'_{m-1,n-1}$ (only one value in the

component is filled in and the same technique can be used for all the blue elements). Similarly, Figure 10 illustrates the red data component having been transformed in which the transformed red element $R_{m-2,n-2}$ is identified as $R'_{m-2,n-2}$. In this state, the image data can still be considered “raw” data. For example, the mathematical process performed on the data are entirely reversible such that all of the original values can be obtained by reversing those processes.

[0084] With continued reference to Figure 8, after the operation block 56, the flowchart 50 can move on to an operation block 58. In the operation block 58, the resulting data, which is raw or can be substantially raw, can be further compressed to using any known compression algorithm. For example, the compression module 22 (Figure 1) can be configured to perform such a compression algorithm. After compression, the compressed raw data can be stored in the storage device 24 (Figure 1).

[0085] Figure 8A illustrates a modification of the flowchart 50, identified by the reference numeral 50'. Some of the steps described above with reference to the flowchart 50 can be similar or the same as some of the corresponding steps of the flowchart 50' and thus are identified with the same reference numerals.

[0086] As shown in Figure 8A, the flowchart 50', in some embodiments, can optionally omit operation block 54. In some embodiments, the flowchart 50' can also include an operation block 57 in which a look up table can be applied to the image data. For example, an optional look-up table, represented by the curve of Figure 11, can be used to enhance further compression. In some embodiments, the look-up table of Figure 11 is only used for the green picture elements. In other embodiments, the look-up table can also be used for red and blue picture elements. The same look-up table may be used for the three different colors, or each color may have its own look-up table. Additionally, processes other than that represented by the curve of Figure 11 can also be applied.

[0087] By processing the image data in the manner described above with reference to Figures 8 and 8A, it has been discovered that the image data from the image sensor 18 can be compressed by a compression ratio of 6 to 1 or greater and remain visually lossless. Additionally, although the image data has been transformed (e.g., by the subtraction of green image data) all of the raw image data is still available to an end user. For example,

by reversing certain of the processes, all or substantially all of the original raw data can be extracted and thus further processed, filtered, and/or demosaiced using any process the user desires.

[0088] For example, with reference to Figure 12, the data stored in the storage device 24 can be decompressed and demosaiced. Optionally, the camera 10 can be configured to perform the method illustrated by flowchart 60. For example, but without limitation, the playback module 28 can be configured to perform the method illustrated by flowchart 60. However, a user can also transfer the data from the storage device 24 into a separate workstation and apply any or all of the steps and/or operations of the flowchart 60.

[0089] With continued reference to Figure 12, the flowchart 60 can begin with the operation block 62, in which the data from the storage device 24 is decompressed. For example, the decompression of the data in operation block 62 can be the reverse of the compression algorithm performed in operational block 58 (Figure 8). After the operation block 62, the flowchart 60 can move on to an operation block 64.

[0090] In the operation block 64, a process performed in operation block 56 (Figure 8) can be reversed. For example, the inverse of the curve of Figure 11 or the inverse of any of the other functions described above with reference to operation block 56 of Figures 8 and 8A, can be applied to the image data. After the operation block 64, the flowchart 60 can move on to a step 66.

[0091] In the operation block 66, the green picture elements can be demosaiced. For example, as noted above, all the values from the data components Green 1 and/or Green 2 (Figure 7) can be stored in the storage device 24. For example, with reference to Figure 5, the green image data from the data components Green 1, Green 2 can be arranged according to the original Bayer pattern applied by the image sensor 18. The green data can then be further demosaiced by any known technique, such as, for example, linear interpolation, bilinear, etc.

[0092] Figure 13 illustrates an exemplary layout of green image data demosaiced from all of the raw green image data. The green image elements identified with the letter G_x represent original raw (decompressed) image data and the elements identified with “ DG_x ” represent elements that were derived from the original data through the demosaic process.

This nomenclature is used with regard to the below descriptions of the demosaicing process for the other colors. Figure 14 illustrates an exemplary image data layout for green image data demosaiced from $\frac{1}{2}$ of the original green image data.

[0093] With continued reference to Figure 12, the flowchart 60 can, after the operation block 66, move on to an operation block 68. In the operation block 68, the demosaiced green image data can be further processed. For example, but without limitation, noise reduction techniques can be applied to the green image data. However, any other image processing technique, such as anti-aliasing techniques, can also be applied to the green image data. After the operation block 68, the flowchart 60 can move on to an operation block 70.

[0094] In the operation block 70, the red and blue image data can be demosaiced. For example, firstly, the blue image data of Figure 9 can be rearranged according to the original Bayer pattern (Figure 15). The surrounding elements, as shown in Figure 16, can be demosaiced from the existing blue image data using any known demosaicing technique, including linear interpolation, bilinear, etc. As a result of demosaicing step, there will be blue image data for every pixel as shown in Figure 16. However, this blue image data was demosaiced based on the modified blue image data of Figure 9, i.e., blue image data values from which green image data values were subtracted.

[0095] The operation block 70 can also include a demosaicing process of the red image data. For example, the red image data from Figure 10 can be rearranged according to the original Bayer pattern and further demosaiced by any known demosaicing process such as linear interpolation, bilinear, etc.

[0096] After the operation block 70, the flowchart can move on to an operation block 72. In the operation block 72, the demosaiced red and blue image data can be reconstructed from the demosaiced green image data.

[0097] In some embodiments, each of the red and blue image data elements can be reconstructed by adding in the green value from co-sited green image element (the green image element in the same column “m” and row “n” position). For example, after demosaicing, the blue image data includes a blue element value $DB_{m-2,n-2}$. Because the original Bayer pattern of Figure 3 did not include a blue element at this position, this blue value $DB_{m-2,n-2}$ was derived through the demosaicing process noted above, based on, for

example, blue values from any one of the elements $B_{m-3,n-3}$, $B_{m-1,n-3}$, $B_{m-3,n-1}$, and $B_{m-1,n-1}$ or by any other technique or other blue image elements. As noted above, these values were modified in operation block 54 (Figure 8) and thus do not correspond to the original blue image data detected by the image sensor 18. Rather, an average green value had been subtracted from each of these values. Thus, the resulting blue image data $DB_{m-2,n-2}$ also represents blue data from which green image data has been subtracted. Thus, in one embodiment, the demosaiced green image data for element $DG_{m-2,n-2}$ can be added to the blue image value $DB_{m-2,n-2}$ thereby resulting in a reconstructed blue image data value.

[0098] In some embodiments, optionally, the blue and/or red image data can first be reconstructed before demosaicing. For example, the transformed blue image data $B'_{m-1,n-1}$ can be first reconstructed by adding the average value of the surrounding green elements. This would result in obtaining or recalculating the original blue image data $B_{m-1,n-1}$. This process can be performed on all of the blue image data. Subsequently, the blue image data can be further demosaiced by any known demosaicing technique. The red image data can also be processed in the same or similar manners.

[0099] Figure 12A illustrates a modification of the flowchart 60, identified by the reference numeral 60'. Some of the steps described above with reference to the flowchart 60 can be similar or the same as some of the corresponding steps of the flowchart 60' and thus are identified with the same reference numerals.

[0100] As shown in Figure 12A, the flow chart 60' can include the operation block 68' following operation block 62. In operation block 68', a noise reduction technique can be performed on the image data. For example, but without limitation, noise reduction techniques can be applied to the green image data. However, any other image processing technique, such as anti-aliasing techniques, can also be applied to the green image data. After operation block 68', the flow chart can move on to operation block 70'

[0101] In operation block 70', the image data can be demosaiced. In the description set forth above with reference to operation blocks 66 and 70, the green, red, and blue image data can be demosaiced in two steps. However, in the present flow chart 60', the demosaicing of all three colors of image data is represented in a single step, although the same demosaicing techniques described above can be used for this demosaicing process.

After the operation block 70', the flow chart can move on to operation block 72, in which the red and blue image data can be reconstructed, and operation block 64 in which an inverse look-up table can be applied.

[0102] After the image data has been decompressed and processed according to either of the flow charts 70 or 70', or any other suitable process, the image data can be further processed as demosaiced image data.

[0103] By demosaicing the green image data before reconstructing the red and blue image data, certain further advantages can be achieved. For example, as noted above, the human eye is more sensitive to green light. Demosaicing and processing the green image data optimize the green image values, to which the human eye is more sensitive. Thus, the subsequent reconstruction of the red and blue image data will be affected by the processing of the green image data.

[0104] Additionally, Bayer patterns have twice as many green elements as red and blue elements. Thus, in embodiments where all of the green data is retained, there is twice as much image data for the green elements as compared to either the red or blue image data elements. Thus, the demosaicing techniques, filters, and other image processing techniques result in a better demosaiced, sharpened, or otherwise filtered image. Using these demosaiced values to reconstruct and demosaic the red and blue image data transfers the benefits associated with the higher resolution of the original green data to the process, reconstruction, and demosaicing of the red and blue elements. As such, the resulting image is further enhanced.

WHAT IS CLAIMED IS:

1. A video camera comprising:

a portable housing having an opening through which light emanating from outside the portable housing enters the portable housing;

a memory device supported by the portable housing;

an image sensor comprising first, second, and third pluralities of light sensitive devices arranged with respect to one another in a plane defined by the image sensor such that the first, second, and third pluralities of light sensitive devices are intermingled, defining an intermingled pattern, the first, second, and third pluralities of light sensitive devices being configured to detect first, second, and third colors, respectively, the first, second, and third colors being different from each other, the image sensor being configured to convert light entering the portable housing through the opening into raw mosaiced image data comprising one data value for each of the light sensitive devices included in the first, second, and third pluralities of light sensitive devices, the image sensor being configured to output the raw mosaiced image data at a resolution of at least 2k and at a frame rate of at least about 23 frames per second; and

electronics having an image processing module and a compression module implemented therein,

the image processing module connected between the image sensor and the memory device, the image processing module configured to process the raw mosaiced image data from the image sensor and output processed image data based on the raw mosaiced image data from the image sensor, the processed image data including less than three data values for each of the light sensitive devices included in the first, second, and third pluralities of light sensitive devices, and

the compression module connected between the image sensor and the memory device, the compression module configured to compress the processed image data with a mathematically lossy compression technique into compressed processed image

data such that the compressed processed image data can be decompressed and demosaiced into a substantially visually lossless image of at least 2k resolution,

wherein the memory device receives the compressed processed image data at a rate of at least about 23 frames per second.

2. A video camera according to claim 1 wherein the image sensor is configured to output the raw mosaiced image data at a resolution of at least 2k and at a frame rate of at least 23 frames per second, wherein the compressed processed image data can be decompressed and demosaiced into a visually lossless image of at least 2k resolution, and wherein the memory device receives the compressed processed image data at a rate of at least 23 frames per second.

3. A video camera according to claim 1 wherein the image sensor is configured to output the raw mosaiced image data at a resolution of at least 4k, and the compressed processed image data can be decompressed and demosaiced into a substantially visually lossless image of at least 4k resolution.

4. A video camera according to claim 1 wherein the image sensor is configured to output the raw mosaiced image data at a resolution of at least 4k and at a frame rate of at least 23 frames per second, wherein the compressed processed image data can be decompressed and demosaiced into a visually lossless image of at least 4k resolution, and wherein the memory device receives the compressed processed image data at a rate of at least 23 frames per second.

5. A video camera according to claim 1 wherein the one data value for each of the first plurality of light sensitive devices is representative of light of only the first color, the one data value for each of the second plurality of light sensitive devices is representative of light of only the second color, and the one data value for each of the third plurality of light sensitive devices is representative of only the third color, and wherein the processed image data does not include separate data values for the first, second, and third colors for each of the light sensitive devices.

6. A video camera according to claim 1 wherein the memory device is disposed within the portable housing.

7. A video camera according to claim 1 wherein the memory device is supported on the outside of the portable housing.

8. A video camera according to claim 1 additionally comprising a playback module configured to receive the compressed processed image data from the memory device, and decompress and demosaic the compressed processed image data into demosaiced image data that includes three data values for each of the light sensitive devices included in the first, second, and third pluralities of light sensitive devices.

9. A video camera according to claim 1 wherein the compression module comprises a compression chip.

10. A video camera according to claim 1 wherein the compression technique is a wavelet compression technique.

11. A video camera according to claim 1 wherein the image processing module is configured to process the raw mosaiced image data at least in part by applying a pre-emphasis function to the raw mosaiced image data, wherein the pre-emphasis function is configured to increase data values of the mosaiced image data corresponding to relatively dark image regions and to decrease data values of the mosaiced image data corresponding to relatively bright image regions.

12. A video camera according to claim 1 wherein the image sensor is configured to output the raw mosaiced image data at a resolution falling within a range between and inclusive of 2k and 4.5k and at a frame rate falling within a range between and inclusive of 23 and 120 frames per second, wherein the compression module is configured to compress the processed image data with a mathematically lossy compression technique into compressed processed image data such that the compressed processed image data can be decompressed and demosaiced into a substantially visually lossless image having a resolution falling within a range between and inclusive of 2k and 4.5k resolution, and wherein the memory device receives the compressed processed image data at a rate falling within a range between and inclusive of 23 frames per second and 120 frames per second.

13. A video camera according to claim 1 wherein the image sensor is configured to output the raw mosaiced image data at a resolution that is one of 2k, 4k, and 4.5k and at a frame rate falling within a range between and inclusive of 23 and 120 frames per second,

wherein the compression module is configured to compress the processed image data with a mathematically lossy compression technique into compressed processed image data such that the compressed processed image data can be decompressed and demosaiced into a substantially visually lossless image having a resolution that is one of 2k, 4k, and 4.5k, and wherein the memory device receives the compressed processed image data at a rate falling within a range between and inclusive of 23 frames per second and 120 frames per second.

14. A video camera according to claim 1 wherein the memory device is sufficiently large to store image data from the compression module corresponding to at least about 30 minutes of video at 12 mega pixel resolution, 12-bit color resolution, and at 60 frames per second.

15. A video camera according to claim 1 wherein the image sensor is a CMOS sensor.

16. A method of recording motion video with a camera, the method comprising:

receiving light with an image sensor of a camera, the image sensor comprising first, second, and third pluralities of light sensitive devices arranged with respect to one another in a plane defined by the image sensor such that the first, second, and third pluralities of light sensitive devices are intermingled, defining an intermingled pattern, the first, second, and third pluralities of light sensitive devices being configured to detect first, second, and third colors, respectively, the first, second, and third colors being different from each other;

converting the light received by the image sensor into mosaiced image data at a resolution of least 2k and at a frame rate of at least about 23 frames per second, the mosaiced image data comprising one data value for each of the light sensitive devices included in the first, second, and third pluralities of light sensitive devices;

with electronics of the camera, processing the mosaiced image data from the image sensor and outputting processed image data based on the mosaiced image data from the image sensor, the processed image data including less than three data values for each of the light sensitive devices included in the first, second, and third pluralities of light sensitive devices;

with electronics of the camera, compressing the processed image data with a mathematically lossy compression technique into compressed processed image data

such that the compressed processed image data can be decompressed and demosaiced into a substantially visually lossless image of at least 2k resolution; and

recording the compressed processed image data onto a memory device of the camera at a rate of at least about 23 frames per second.

17. A method according to claim 16 wherein said converting comprises converting the light received by the image sensor into mosaiced image data at a resolution of least 2k and at a frame rate of at least 23 frames per second, wherein the compressed processed image data can be decompressed and demosaiced into a visually lossless image of at least 2k resolution, and wherein said recording comprises recording the compressed processed image data onto a memory device of the camera at a rate of at least 23 frames per second.

18. A method according to claim 16 wherein said converting comprises converting the light received by the image sensor into mosaiced image data at a resolution of least 4k, and the compressed processed image data can be decompressed and demosaiced into a substantially visually lossless image of at least 4k resolution.

19. A method according to claim 16 wherein said converting comprises converting the light received by the image sensor into mosaiced image data at a resolution of least 4k and at a frame rate of at least 23 frames per second, wherein the compressed processed image data can be decompressed and demosaiced into a visually lossless image of at least 4k resolution, and wherein said recording comprises recording the compressed processed image data onto a memory device of the camera at a rate of at least 23 frames per second.

20. A method according to claim 16 wherein the one data value for each of the first plurality of light sensitive devices is representative of light of only the first color, the one data value for each of the second plurality of light sensitive devices is representative of light of only the second color, and the one data value for each of the third plurality of light sensitive devices is representative of only the third color, and wherein the processed image data does not include separate data values for the first, second, and third colors for each of the light sensitive devices.

21. A method according to claim 16 wherein said recording comprises recording the compressed processed image data onto a memory device disposed within a portable housing of the camera.

22. A method according to claim 16 wherein said recording comprises recording the compressed processed image data onto a memory device supported on the outside of a portable housing of the camera.

23. A method according to claim 16 additionally comprising:

receiving the compressed processed image data from the memory device with a playback module implemented in the electronics of the camera; and

decompressing and demosaicing the compressed processed image data into demosaiced image data that includes three data values for each of the light sensitive devices included in the first, second, and third pluralities of light sensitive devices.

24. A method according to claim 16 wherein the electronics comprise a compression chip and said compressing is done using the compression chip.

25. A method according to claim 16 wherein the mosaiced image data is raw mosaiced image data.

26. A method according to claim 16 wherein the compression technique is a wavelet compression technique.

27. A method according to claim 16 wherein said processing the image data comprises processing the mosaiced image data at least in part by applying a pre-emphasis function to the mosaiced image data, wherein the application of the pre-emphasis function increases data values of the mosaiced image data corresponding to relatively dark image regions and decreases data values of the mosaiced image data corresponding to relatively bright image regions.

28. A method according to claim 16 wherein said converting comprises converting the light received by the image sensor into mosaiced image data at a resolution falling within a range between and inclusive of 2k and 4.5k and at a frame rate falling within a range between and inclusive of 23 and 120 frames per second, wherein said compressing comprises compressing the processed image data with a mathematically lossy compression technique into compressed processed image data such that the compressed processed image data can be decompressed and demosaiced into a substantially visually lossless image having a resolution falling within a range between and inclusive of 2k and 4.5k resolution, and said recording

comprises recording the compressed processed image data at a rate falling within a range between and inclusive of 23 frames per second and 120 frames per second.

29. A method according to claim 16 wherein said converting comprises converting the light received by the image sensor into mosaiced image data at a resolution that is one of 2k, 4k, and 4.5k and at a frame rate falling within a range between and inclusive of 23 and 120 frames per second, wherein said compressing comprises compressing the processed image data with a mathematically lossy compression technique into compressed processed image data such that the compressed processed image data can be decompressed and demosaiced into a substantially visually lossless image having a resolution that is one of 2k, 4k, and 4.5k, and said recording comprises recording the compressed processed image data at a rate falling within a range between and inclusive of 23 frames per second and 120 frames per second.

30. A method according to claim 16 wherein the memory device is sufficiently large to store image data from the compression module corresponding to at least about 30 minutes of video at 12 mega pixel resolution, 12-bit color resolution, and at 60 frames per second.

VIDEO CAMERA

ABSTRACT OF THE DISCLOSURE

Embodiments provide a video camera configured to capture, compress, and store video image data in a memory of the video camera at a rate of at least about twenty three frames per second. The video image data can be mosaiced image data, and the compressed, mosaiced image data may remain substantially visually lossless upon decompression and demosaicing.

18870676

Under the Paperwork Reduction Act of 1995, no persons are required to respond to a collection of information unless it displays a valid OMB control number.

PATENT APPLICATION FEE DETERMINATION RECORD Substitute for Form PTO-875	Application or Docket Number 14/485,612	Filing Date 09/12/2014	<input type="checkbox"/> To be Mailed
---	---	----------------------------------	---------------------------------------

ENTITY: LARGE SMALL MICRO

APPLICATION AS FILED – PART I

FOR	NUMBER FILED	NUMBER EXTRA	RATE (\$)	FEE (\$)
<input checked="" type="checkbox"/> BASIC FEE <small>(37 CFR 1.16(a), (b), or (c))</small>	N/A	N/A	N/A	280
<input checked="" type="checkbox"/> SEARCH FEE <small>(37 CFR 1.16(k), (l), or (m))</small>	N/A	N/A	N/A	600
<input checked="" type="checkbox"/> EXAMINATION FEE <small>(37 CFR 1.16(o), (p), or (q))</small>	N/A	N/A	N/A	720
TOTAL CLAIMS <small>(37 CFR 1.16(i))</small>	30 minus 20 =	* 10	x \$80 =	800
INDEPENDENT CLAIMS <small>(37 CFR 1.16(h))</small>	2 minus 3 =	* 0	x \$420 =	0
<input type="checkbox"/> APPLICATION SIZE FEE <small>(37 CFR 1.16(s))</small>	If the specification and drawings exceed 100 sheets of paper, the application size fee due is \$310 (\$155 for small entity) for each additional 50 sheets or fraction thereof. See 35 U.S.C. 41(a)(1)(G) and 37 CFR 1.16(s).			
<input type="checkbox"/> MULTIPLE DEPENDENT CLAIM PRESENT <small>(37 CFR 1.16(j))</small>				
* If the difference in column 1 is less than zero, enter "0" in column 2.			TOTAL	2400

APPLICATION AS AMENDED – PART II

	(Column 1)	(Column 2)	(Column 3)	PRESENT EXTRA	RATE (\$)	ADDITIONAL FEE (\$)
AMENDMENT	CLAIMS REMAINING AFTER AMENDMENT		HIGHEST NUMBER PREVIOUSLY PAID FOR			
	Total (37 CFR 1.16(i))	*	Minus	**	=	X \$ =
	Independent (37 CFR 1.16(h))	*	Minus	***	=	X \$ =
	<input type="checkbox"/> Application Size Fee (37 CFR 1.16(s))					
<input type="checkbox"/> FIRST PRESENTATION OF MULTIPLE DEPENDENT CLAIM (37 CFR 1.16(j))						
					TOTAL ADD'L FEE	

	(Column 1)	(Column 2)	(Column 3)	PRESENT EXTRA	RATE (\$)	ADDITIONAL FEE (\$)
AMENDMENT	CLAIMS REMAINING AFTER AMENDMENT		HIGHEST NUMBER PREVIOUSLY PAID FOR			
	Total (37 CFR 1.16(i))	*	Minus	**	=	X \$ =
	Independent (37 CFR 1.16(h))	*	Minus	***	=	X \$ =
	<input type="checkbox"/> Application Size Fee (37 CFR 1.16(s))					
<input type="checkbox"/> FIRST PRESENTATION OF MULTIPLE DEPENDENT CLAIM (37 CFR 1.16(j))						
					TOTAL ADD'L FEE	

* If the entry in column 1 is less than the entry in column 2, write "0" in column 3.
 ** If the "Highest Number Previously Paid For" IN THIS SPACE is less than 20, enter "20".
 *** If the "Highest Number Previously Paid For" IN THIS SPACE is less than 3, enter "3".
 The "Highest Number Previously Paid For" (Total or Independent) is the highest number found in the appropriate box in column 1.

LDRG
/EVA GILLIS/

This collection of information is required by 37 CFR 1.16. The information is required to obtain or retain a benefit by the public which is to file (and by the USPTO to process) an application. Confidentiality is governed by 35 U.S.C. 122 and 37 CFR 1.14. This collection is estimated to take 12 minutes to complete, including gathering, preparing, and submitting the completed application form to the USPTO. Time will vary depending upon the individual case. Any comments on the amount of time you require to complete this form and/or suggestions for reducing this burden, should be sent to the Chief Information Officer, U.S. Patent and Trademark Office, U.S. Department of Commerce, P.O. Box 1450, Alexandria, VA 22313-1450. DO NOT SEND FEES OR COMPLETED FORMS TO THIS ADDRESS. **SEND TO: Commissioner for Patents, P.O. Box 1450, Alexandria, VA 22313-1450.**

If you need assistance in completing the form, call 1-800-PTO-9199 and select option 2.



UNITED STATES PATENT AND TRADEMARK OFFICE

UNITED STATES DEPARTMENT OF COMMERCE
United States Patent and Trademark Office
Address: COMMISSIONER FOR PATENTS
P.O. Box 1450
Alexandria, Virginia 22313-1450
www.uspto.gov

Table with 7 columns: APPLICATION NUMBER, FILING or 371(c) DATE, GRP ART UNIT, FIL FEE REC'D, ATTY,DOCKET,NO, TOT CLAIMS, IND CLAIMS. Row 1: 14/485,612, 09/12/2014, 2673, 2540, REDCOM.007C4, 30, 2

CONFIRMATION NO. 1068

20995
KNOBBE MARTENS OLSON & BEAR LLP
2040 MAIN STREET
FOURTEENTH FLOOR
IRVINE, CA 92614

FILING RECEIPT



Date Mailed: 09/22/2014

Receipt is acknowledged of this non-provisional patent application. The application will be taken up for examination in due course. Applicant will be notified as to the results of the examination. Any correspondence concerning the application must include the following identification information: the U.S. APPLICATION NUMBER, FILING DATE, NAME OF APPLICANT, and TITLE OF INVENTION. Fees transmitted by check or draft are subject to collection. Please verify the accuracy of the data presented on this receipt. If an error is noted on this Filing Receipt, please submit a written request for a Filing Receipt Correction. Please provide a copy of this Filing Receipt with the changes noted thereon. If you received a "Notice to File Missing Parts" for this application, please submit any corrections to this Filing Receipt with your reply to the Notice. When the USPTO processes the reply to the Notice, the USPTO will generate another Filing Receipt incorporating the requested corrections

Inventor(s)

James H. Jannard, Las Vegas, NV;
Thomas Graeme Nattress, Acton, CANADA;

Applicant(s)

RED.COM, INC., Irvine, CA

Power of Attorney: The patent practitioners associated with Customer Number 20995

Domestic Priority data as claimed by applicant

This application is a CON of 13/464,803 05/04/2012
which is a CON of 12/101,882 04/11/2008 PAT 8174560
which claims benefit of 60/911,196 04/11/2007
and claims benefit of 61/017,406 12/28/2007

Foreign Applications for which priority is claimed (You may be eligible to benefit from the Patent Prosecution Highway program at the USPTO. Please see http://www.uspto.gov for more information.) - None.

Foreign application information must be provided in an Application Data Sheet in order to constitute a claim to foreign priority. See 37 CFR 1.55 and 1.76.

If Required, Foreign Filing License Granted: 09/18/2014

The country code and number of your priority application, to be used for filing abroad under the Paris Convention, is US 14/485,612

Projected Publication Date: 01/01/2015

Non-Publication Request: No

Early Publication Request: No

Title

VIDEO CAMERA

Preliminary Class

358

Statement under 37 CFR 1.55 or 1.78 for AIA (First Inventor to File) Transition Applications: No

PROTECTING YOUR INVENTION OUTSIDE THE UNITED STATES

Since the rights granted by a U.S. patent extend only throughout the territory of the United States and have no effect in a foreign country, an inventor who wishes patent protection in another country must apply for a patent in a specific country or in regional patent offices. Applicants may wish to consider the filing of an international application under the Patent Cooperation Treaty (PCT). An international (PCT) application generally has the same effect as a regular national patent application in each PCT-member country. The PCT process **simplifies** the filing of patent applications on the same invention in member countries, but **does not result** in a grant of "an international patent" and does not eliminate the need of applicants to file additional documents and fees in countries where patent protection is desired.

Almost every country has its own patent law, and a person desiring a patent in a particular country must make an application for patent in that country in accordance with its particular laws. Since the laws of many countries differ in various respects from the patent law of the United States, applicants are advised to seek guidance from specific foreign countries to ensure that patent rights are not lost prematurely.

Applicants also are advised that in the case of inventions made in the United States, the Director of the USPTO must issue a license before applicants can apply for a patent in a foreign country. The filing of a U.S. patent application serves as a request for a foreign filing license. The application's filing receipt contains further information and guidance as to the status of applicant's license for foreign filing.

Applicants may wish to consult the USPTO booklet, "General Information Concerning Patents" (specifically, the section entitled "Treaties and Foreign Patents") for more information on timeframes and deadlines for filing foreign patent applications. The guide is available either by contacting the USPTO Contact Center at 800-786-9199, or it can be viewed on the USPTO website at <http://www.uspto.gov/web/offices/pac/doc/general/index.html>.

For information on preventing theft of your intellectual property (patents, trademarks and copyrights), you may wish to consult the U.S. Government website, <http://www.stopfakes.gov>. Part of a Department of Commerce initiative, this website includes self-help "toolkits" giving innovators guidance on how to protect intellectual property in specific countries such as China, Korea and Mexico. For questions regarding patent enforcement issues, applicants may call the U.S. Government hotline at 1-866-999-HALT (1-866-999-4258).

LICENSE FOR FOREIGN FILING UNDER
Title 35, United States Code, Section 184
Title 37, Code of Federal Regulations, 5.11 & 5.15

GRANTED

The applicant has been granted a license under 35 U.S.C. 184, if the phrase "IF REQUIRED, FOREIGN FILING LICENSE GRANTED" followed by a date appears on this form. Such licenses are issued in all applications where the conditions for issuance of a license have been met, regardless of whether or not a license may be required as set forth in 37 CFR 5.15. The scope and limitations of this license are set forth in 37 CFR 5.15(a) unless an earlier license has been issued under 37 CFR 5.15(b). The license is subject to revocation upon written notification. The date indicated is the effective date of the license, unless an earlier license of similar scope has been granted under 37 CFR 5.13 or 5.14.

This license is to be retained by the licensee and may be used at any time on or after the effective date thereof unless it is revoked. This license is automatically transferred to any related applications(s) filed under 37 CFR 1.53(d). This license is not retroactive.

The grant of a license does not in any way lessen the responsibility of a licensee for the security of the subject matter as imposed by any Government contract or the provisions of existing laws relating to espionage and the national security or the export of technical data. Licensees should apprise themselves of current regulations especially with respect to certain countries, of other agencies, particularly the Office of Defense Trade Controls, Department of State (with respect to Arms, Munitions and Implements of War (22 CFR 121-128)); the Bureau of Industry and Security, Department of Commerce (15 CFR parts 730-774); the Office of Foreign Assets Control, Department of Treasury (31 CFR Parts 500+) and the Department of Energy.

NOT GRANTED

No license under 35 U.S.C. 184 has been granted at this time, if the phrase "IF REQUIRED, FOREIGN FILING LICENSE GRANTED" DOES NOT appear on this form. Applicant may still petition for a license under 37 CFR 5.12, if a license is desired before the expiration of 6 months from the filing date of the application. If 6 months has lapsed from the filing date of this application and the licensee has not received any indication of a secrecy order under 35 U.S.C. 181, the licensee may foreign file the application pursuant to 37 CFR 5.15(b).

SelectUSA

The United States represents the largest, most dynamic marketplace in the world and is an unparalleled location for business investment, innovation, and commercialization of new technologies. The U.S. offers tremendous resources and advantages for those who invest and manufacture goods here. Through SelectUSA, our nation works to promote and facilitate business investment. SelectUSA provides information assistance to the international investor community; serves as an ombudsman for existing and potential investors; advocates on behalf of U.S. cities, states, and regions competing for global investment; and counsels U.S. economic development organizations on investment attraction best practices. To learn more about why the United States is the best country in the world to develop technology, manufacture products, deliver services, and grow your business, visit <http://www.SelectUSA.gov> or call +1-202-482-6800.



UNITED STATES PATENT AND TRADEMARK OFFICE

UNITED STATES DEPARTMENT OF COMMERCE
United States Patent and Trademark Office
Address: COMMISSIONER FOR PATENTS
P.O. Box 1450
Alexandria, Virginia 22313-1450
www.uspto.gov

Table with 4 columns: APPLICATION NUMBER (14/485,612), FILING OR 371(C) DATE (09/12/2014), FIRST NAMED APPLICANT (James H. Jannard), ATTY. DOCKET NO./TITLE (REDCOM.007C4)

CONFIRMATION NO. 1068

20995
KNOBBE MARTENS OLSON & BEAR LLP
2040 MAIN STREET
FOURTEENTH FLOOR
IRVINE, CA 92614

NOTICE



Date Mailed: 09/22/2014

INFORMATIONAL NOTICE TO APPLICANT

Applicant is notified that the above-identified application contains the deficiencies noted below. No period for reply is set forth in this notice for correction of these deficiencies. However, if a deficiency relates to the inventor's oath or declaration, the applicant must file an oath or declaration in compliance with 37 CFR 1.63, or a substitute statement in compliance with 37 CFR 1.64, executed by or with respect to each actual inventor no later than the expiration of the time period set in the "Notice of Allowability" to avoid abandonment. See 37 CFR 1.53(f).

The item(s) indicated below are also required and should be submitted with any reply to this notice to avoid further processing delays.

- A properly executed inventor's oath or declaration has not been received for the following inventor(s):
James H. Jannard
Thomas Graeme Nattress

INFORMATION DISCLOSURE STATEMENT BY APPLICANT	Application No.	14/485612
	Filing Date	September 12, 2014
	First Named Inventor	James H. Jannard
	Art Unit	2661
<i>(Multiple sheets used when necessary)</i>	Examiner	Unknown
SHEET 1 OF 14	Attorney Docket No.	REDCOM.007C4

U.S. PATENT DOCUMENTS					
Examiner Initials	Cite No.	Document Number <i>Number - Kind Code (if known)</i> Example: 1,234,567 B1	Publication Date MM-DD-YYYY	Name of Patentee or Applicant	Pages, Columns, Lines Where Relevant Passages or Relevant Figures Appear
	1	3,972,010	07-27-1976	Dolby	
	2	4,200,889	04-19-1980	Strobele	
	3	4,316,213	02-16-1982	Wharton et al.	
	4	4,450,487	05-22-1984	Koide	
	5	4,561,012	12-24-1985	Acampora	
	6	5,016,107	05-14-1991	Sasson et al.	
	7	5,040,063	08-13-1991	Citta et al.	
	8	5,049,983	09-17-1991	Matsumoto et al.	
	9	5,249,053	09-28-1993	Jain	
	10	5,255,083	10-19-1993	Capitant et al.	
	11	5,303,062	04-12-1994	Kawarai	
	12	5,343,243	08-30-1994	Maeda	
	13	5,442,718	08-15-1995	Kobayashi et al.	
	14	5,526,047	06-11-1996	Sawanobori	
	15	5,535,246	07-09-1996	Beech	
	16	5,537,157	07-16-1996	Washino et al.	
	17	5,563,655	10-08-1996	Lathrop	
	18	5,592,224	01-07-1997	Shim	
	19	5,592,237	01-07-1997	Greenway	
	20	5,818,524	10-06-1998	Juen	
	21	5,875,122	02-23-1999	Acharya	
	22	5,949,468	09-07-1999	Asahina et al.	
	23	5,991,515	11-23-1999	Fall et al.	
	24	5,999,220	12-07-1999	Washino	
	25	6,009,201	12-28-1999	Acharya	
	26	6,124,811	09-26-2000	Acharya et al.	
	27	6,154,493	11-28-2000	Acharya et al.	
	28	6,192,086	02-20-2001	Darr	
	29	6,198,505	03-06-2001	Turner et al.	

Examiner Signature	Date Considered
<p>*Examiner: Initial if reference considered, whether or not citation is in conformance with MPEP 609. Draw line through citation if not in conformance and not considered. Include copy of this form with next communication to applicant.</p>	

T¹ - Place a check mark in this area when an English language Translation is attached.

INFORMATION DISCLOSURE STATEMENT BY APPLICANT	Application No.	14/485612
	Filing Date	September 12, 2014
	First Named Inventor	James H. Jannard
	Art Unit	2661
<i>(Multiple sheets used when necessary)</i>	Examiner	Unknown
SHEET 2 OF 14	Attorney Docket No.	REDCOM.007C4

U.S. PATENT DOCUMENTS					
Examiner Initials	Cite No.	Document Number <i>Number - Kind Code (if known)</i> Example: 1,234,567 B1	Publication Date MM-DD-YYYY	Name of Patentee or Applicant	Pages, Columns, Lines Where Relevant Passages or Relevant Figures Appear
	30	6,262,763	07-17-2001	Totsuka	
	31	6,269,217	07-31-2001	Rodriguez	
	32	6,275,263	08-14-2001	Hu	
	33	6,285,794	09-04-2001	Georgiev et al.	
	34	6,314,206	11-06-2001	Sato	
	35	6,466,699	10-15-2002	Schwartz et al.	
	36	6,567,988	05-20-2003	Okawa	
	37	6,597,860	07-22-2003	Song et al.	
	38	6,697,106	02-24-2004	Saito	
	39	6,778,709	08-17-2004	Taubman	
	40	6,798,901	09-28-2004	Acharya et al.	
	41	6,825,876	11-30-2004	Easwar et al.	
	42	6,859,226	02-22-2005	Kawamura et al.	
	43	6,867,717	03-15-2005	Ion	
	44	6,937,276	08-30-2005	Chung	
	45	6,944,349	09-13-2005	Onno et al.	
	46	6,958,774	10-25-2005	Kuroiwa	
	47	6,983,074	01-03-2006	Clauson et al.	
	48	6,989,773	01-24-2006	Wee et al.	
	49	6,990,240	01-24-2006	Hagiwara	
	50	6,995,793	02-07-2006	Albadawi et al.	
	51	6,995,794	02-07-2006	Hsu et al.	
	52	7,038,719	05-02-2006	Hirai	
	53	7,050,642	05-23-2006	Graffagnino	
	54	7,092,016	08-15-2006	Morton et al.	
	55	7,095,899	08-22-2006	Malvar	
	56	7,110,605	09-19-2006	Marcellin et al.	
	57	7,113,645	09-26-2006	Sano et al.	
	58	7,126,634	10-24-2006	Kato	

Examiner Signature	Date Considered
<p>*Examiner: Initial if reference considered, whether or not citation is in conformance with MPEP 609. Draw line through citation if not in conformance and not considered. Include copy of this form with next communication to applicant.</p>	

T¹ - Place a check mark in this area when an English language Translation is attached.

INFORMATION DISCLOSURE STATEMENT BY APPLICANT	Application No.	14/485612
	Filing Date	September 12, 2014
	First Named Inventor	James H. Jannard
	Art Unit	2661
<i>(Multiple sheets used when necessary)</i>	Examiner	Unknown
SHEET 3 OF 14	Attorney Docket No.	REDCOM.007C4

U.S. PATENT DOCUMENTS					
Examiner Initials	Cite No.	Document Number <i>Number - Kind Code (if known)</i> Example: 1,234,567 B1	Publication Date MM-DD-YYYY	Name of Patentee or Applicant	Pages, Columns, Lines Where Relevant Passages or Relevant Figures Appear
	59	7,127,116	10-24-2006	Goldstein et al.	
	60	7,155,066	12-26-2006	Baharav	
	61	7,174,045	02-06-2007	Yokonuma	
	62	7,212,313	05-01-2007	Hoel	
	63	7,253,836	08-07-2007	Suzuki et al.	
	64	7,312,821	12-25-2007	Voss	
	65	7,313,286	12-25-2007	Schwartz et al.	
	66	7,324,141	01-29-2008	Kubo et al.	
	67	7,343,043	03-11-2008	Yokonuma	
	68	7,349,579	03-25-2008	Kadowaki et al.	
	69	7,365,658	04-29-2008	Todorov et al.	
	70	7,369,161	05-06-2008	Easwar et al.	
	71	7,376,183	05-20-2008	Weigand et al.	
	72	7,385,647	06-10-2008	Park	
	73	7,388,992	06-17-2008	Atsumi et al.	
	74	7,394,485	07-01-2008	Kim	
	75	7,477,781	01-13-2009	Tanbakuchi	
	76	7,483,909	01-27-2009	Sena et al.	
	77	7,512,283	03-31-2009	Brower	
	78	7,526,134	04-28-2009	Matsubara	
	79	7,577,689	08-18-2009	Masinter et al.	
	80	7,590,301	09-15-2009	Wu	
	81	7,609,300	10-27-2009	Wu	
	82	7,778,473	08-17-2010	Kodama	
	83	7,796,186	09-14-2010	Oshima	
	84	7,830,967 (and entire prosecution history) (REDCOM.007CP1C1)	11-09-2010	Jannard et al.	
	85	7,868,879	01-11-2011	Rizko	
	86	7,898,575	03-01-2011	Ishii	

Examiner Signature	Date Considered
* Examiner: Initial if reference considered, whether or not citation is in conformance with MPEP 609. Draw line through citation if not in conformance and not considered. Include copy of this form with next communication to applicant.	

T¹ - Place a check mark in this area when an English language Translation is attached.

INFORMATION DISCLOSURE STATEMENT BY APPLICANT	Application No.	14/485612
	Filing Date	September 12, 2014
	First Named Inventor	James H. Jannard
	Art Unit	2661
<i>(Multiple sheets used when necessary)</i>	Examiner	Unknown
SHEET 4 OF 14	Attorney Docket No.	REDCOM.007C4

U.S. PATENT DOCUMENTS					
Examiner Initials	Cite No.	Document Number <i>Number - Kind Code (if known)</i> Example: 1,234,567 B1	Publication Date MM-DD-YYYY	Name of Patentee or Applicant	Pages, Columns, Lines Where Relevant Passages or Relevant Figures Appear
	87	7,907,791	03-15-2011	Kinrot	
	88	7,936,919	05-03-2011	Kameyama	
	89	8,014,597	09-06-2011	Newman	
	90	8,174,560 C1 (and entire prosecution history) (REDCOM.007A)	05-16-2014	Jannard et al.	
	91	8,237,830 (and entire prosecution history) (REDCOM.007CP1)	08-07-2012	Jannard et al.	
	92	8,358,357 (and entire prosecution history) (REDCOM.007C2)	01-22-2013	Jannard et al.	
	93	RE 37,342	08-02-2001	Washino et al.	
	94	RE 38,079	04-15-2003	Washino et al.	
	95	2002/0041707	04-11-2002	Newman	
	96	2002/0063787	05-30-2002	Watanabe	
	97	2002/0196354	12-26-2002	Chang et al.	
	98	2003/0007567	01-09-2003	Newman et al.	
	99	2003/0011747	01-16-2003	Lenz	
	100	2003/0018750	01-23-2003	Onno et al.	
	101	2003/0038885	02-27-2003	Rodriguez	
	102	2003/0122037	07-03-2003	Hyde et al.	
	103	2003/0122937	07-03-2003	Guarnera et al.	
	104	2003/0156188	08-21-2003	Abrams Jr.	
	105	2003/0185302	10-02-2003	Abrams Jr.	
	106	2003/0202106	10-30-2003	Kanleinsberger et al.	
	107	2004/0051793	03-18-2004	Tecu	
	108	2004/0095477	05-20-2004	Maki et al.	
	109	2004/0131274	07-08-2004	Perlmutter et al.	
	110	2004/0165080	08-26-2004	Burks et al.	
	111	2004/0169746	09-02-2004	Chen et al.	
	112	2004/0169751	09-02-2004	Takemura et al.	
	113	2004/0196389	10-07-2004	Honda	

Examiner Signature	Date Considered
<p>*Examiner: Initial if reference considered, whether or not citation is in conformance with MPEP 609. Draw line through citation if not in conformance and not considered. Include copy of this form with next communication to applicant.</p>	

T¹ - Place a check mark in this area when an English language Translation is attached.

INFORMATION DISCLOSURE STATEMENT BY APPLICANT	Application No.	14/485612
	Filing Date	September 12, 2014
	First Named Inventor	James H. Jannard
	Art Unit	2661
<i>(Multiple sheets used when necessary)</i>	Examiner	Unknown
SHEET 5 OF 14	Attorney Docket No.	REDCOM.007C4

U.S. PATENT DOCUMENTS					
Examiner Initials	Cite No.	Document Number <i>Number - Kind Code (if known)</i> Example: 1,234,567 B1	Publication Date MM-DD-YYYY	Name of Patentee or Applicant	Pages, Columns, Lines Where Relevant Passages or Relevant Figures Appear
	114	2004/0201701	10-14-2004	Takagi	
	115	2004/0213472	10-28-2004	Kodama et al.	
	116	2004/0218812	11-04-2004	Douglass	
	117	2004/0246346	12-09-2004	Kim et al.	
	118	2005/0182972	08-18-2005	Apostolopoulos et al.	
	119	2005/0183118	08-18-2005	Wee et al.	
	120	2005/0276496	12-15-2005	Molgaard et al.	
	121	2005/0286797	12-29-2005	Hayaishi	
	122	2006/0007324	01-12-2006	Takei	
	123	2006/0012694	01-19-2006	Yoneda et al.	
	124	2006/0061659	03-23-2006	Niwa	
	125	2006/0061822	03-23-2006	Sung et al.	
	126	2006/0114987	06-01-2006	Roman	
	127	2006/0165178	07-26-2006	Ma et al.	
	128	2006/0165179	07-26-2006	Feuer et al.	
	129	2006/0170786	08-03-2006	Won	
	130	2006/0221199	10-05-2006	Nakajima	
	131	2006/0221203	10-05-2006	Abe et al.	
	132	2006/0221230	10-05-2006	Dutt et al.	
	133	2006/0244842	11-02-2006	Hatano	
	134	2007/0035636	02-15-2007	Wu	
	135	2007/0041634	02-22-2007	Sugimori	
	136	2007/0051817	03-08-2007	Yano	
	137	2007/0091187	04-26-2007	Lin	
	138	2007/0092149	04-26-2007	Sung	
	139	2007/0109316	05-17-2007	Fainstain	
	140	2007/0127095	06-07-2007	Sugimori	
	141	2007/0153093	07-05-2007	Lin et al.	
	142	2007/0160142	07-12-2007	Abrams Jr.	

Examiner Signature	Date Considered
<p>*Examiner: Initial if reference considered, whether or not citation is in conformance with MPEP 609. Draw line through citation if not in conformance and not considered. Include copy of this form with next communication to applicant.</p>	

T¹ - Place a check mark in this area when an English language Translation is attached.

INFORMATION DISCLOSURE STATEMENT BY APPLICANT	Application No.	14/485612
	Filing Date	September 12, 2014
	First Named Inventor	James H. Jannard
	Art Unit	2661
<i>(Multiple sheets used when necessary)</i>	Examiner	Unknown
SHEET 6 OF 14	Attorney Docket No.	REDCOM.007C4

U.S. PATENT DOCUMENTS					
Examiner Initials	Cite No.	Document Number <i>Number - Kind Code (if known)</i> Example: 1,234,567 B1	Publication Date MM-DD-YYYY	Name of Patentee or Applicant	Pages, Columns, Lines Where Relevant Passages or Relevant Figures Appear
	143	2007/0165116	07-19-2007	Hung et al.	
	144	2007/0206852	09-06-2007	McGee	
	145	2007/0216782	09-20-2007	Chernoff	
	146	2007/0285517	12-13-2007	Ishikuro	
	147	2008/0002035	01-03-2008	Yoshida	
	148	2008/0012953	01-17-2008	Yang et al.	
	149	2008/0018746	01-24-2008	Kawanami	
	150	2008/0055426	03-06-2008	Pertsel et al.	
	151	2008/0062272	03-13-2008	Kuroiwa	
	152	2008/0063070	03-13-2008	Schwartz et al.	
	153	2008/0079818	04-03-2008	Takahashi	
	154	2008/0084581	04-10-2008	Kobayashi et al.	
	155	2008/0131013	06-05-2008	Suino et al.	
	156	2008/0259180	10-23-2008	Ovsiannikov	
	157	2008/0273809	11-06-2008	Demos	
	158	2008/0284485	11-20-2008	Schilling	
	159	2008/0301315	12-04-2008	Cheng et al.	
	160	2009/0052797	02-26-2009	Matsushita	
	161	2009/0052861	02-26-2009	Goldman	
	162	2009/0080784	03-26-2009	Luh et al.	
	163	2009/0141140	06-04-2009	Robinson	
	164	2010/0014590	01-21-2010	Smith	
	165	2010/0111489	05-06-2010	Presler	
	166	2012/0294582 (and entire prosecution history) (REDCOM.007C1)	11-22-2012	Jannard et al.	
	167	2013/0113951 (and entire prosecution history) (REDCOM.007CP1C2)	05-09-2013	Jannard et al.	
	168	2014/0226036	08-14-2014	Jannard et al.	

FOREIGN PATENT DOCUMENTS

Examiner Signature	Date Considered
* Examiner: Initial if reference considered, whether or not citation is in conformance with MPEP 609. Draw line through citation if not in conformance and not considered. Include copy of this form with next communication to applicant.	

T¹ - Place a check mark in this area when an English language Translation is attached.

INFORMATION DISCLOSURE STATEMENT BY APPLICANT	Application No.	14/485612
	Filing Date	September 12, 2014
	First Named Inventor	James H. Jannard
	Art Unit	2661
<i>(Multiple sheets used when necessary)</i>	Examiner	Unknown
SHEET 7 OF 14	Attorney Docket No.	REDCOM.007C4

Examiner Initials	Cite No.	Foreign Patent Document Country Code-Number-Kind Code Example: JP 1234567 A1	Publication Date MM-DD-YYYY	Name of Patentee or Applicant	Pages, Columns, Lines Where Relevant Passages or Relevant Figures Appear	T ¹
	169	CA 2,683,636	01-28-2014	Red.com, Inc.		
	170	EP 1 605 403	12-14-2005	ST Microelectronics		
	171	EP 2 145 330	01-20-2010	Red.com, Inc.		
	172	JP 06-054239	02-25-1994	Canon Inc.		X-Abs
	173	JP 2000-069488	03-03-2000	Nikon Corp.		X
	174	JP 2001-515318	09-18-2001	Intel Corporation		X
	175	JP 2002-051266	02-15-2002	Sony Corp.		X
	176	JP 2004-038693	02-05-2004	Canon Inc.		X
	177	JP 2004-248061	09-02-2004	Fuji Photo Film Co., Ltd.		X
	178	JP 2004-260821	09-16-2004	Hewlett-Packard Development Co. LP		X
	179	JP 2004-282780	10-07-2004	Canon Inc.		X
	180	JP 2004-349842	12-09-2004	Fuji Photo Film Co., Ltd.		X
	181	JP 2005-210216	08-04-2005	Konica Minolta Photo Imaging Inc.		X
	182	JP 2006-171524	06-29-2006	Sanyo Electric Co., Ltd.		X
	183	JP 2006-311314	11-09-2006	Matsushita Electric Ind. Co., Ltd.		X
	184	JP 2007-267072	10-11-2007	Sanyo Electric Co., Ltd.		X
	185	JP 2012-523790 (REDCOM.007QPC)	10-04-2012	Red.com, Inc.		X
	186	KR 10-2002-0041778	06-03-2002	Sharp Corporation		X-Abs
	187	WO 91/001613	02-07-1991	Eastman Kodak Co.		
	188	WO 97/009818	03-13-1997	Starcam Systems Inc.		
	189	WO 2008/128112 (REDCOM.007VPC)	10-23-2008	Red.com, Inc.		
	190	WO 92/010911	06-25-1992	Eastman Kodak Co.		
	191	KR 10-2009-0035204	04-09-2009	Samsung Electronics Co., Ltd.		X-Abs

NON PATENT LITERATURE DOCUMENTS

Examiner Initials	Cite No.	Include name of the author (in CAPITAL LETTERS), title of the article (when appropriate), title of the item (book, magazine, journal, serial, symposium, catalog, etc.), date, page(s), volume-issue number(s), publisher, city and/or country where published.	T ¹

Examiner Signature	Date Considered
--------------------	-----------------

***Examiner:** Initial if reference considered, whether or not citation is in conformance with MPEP 609. Draw line through citation if not in conformance and not considered. Include copy of this form with next communication to applicant.

T¹ - Place a check mark in this area when an English language Translation is attached.

INFORMATION DISCLOSURE STATEMENT BY APPLICANT	Application No.	14/485612
	Filing Date	September 12, 2014
	First Named Inventor	James H. Jannard
	Art Unit	2661
<i>(Multiple sheets used when necessary)</i>	Examiner	Unknown
SHEET 8 OF 14	Attorney Docket No.	REDCOM.007C4

NON PATENT LITERATURE DOCUMENTS

Examiner Initials	Cite No.	Include name of the author (in CAPITAL LETTERS), title of the article (when appropriate), title of the item (book, magazine, journal, serial, symposium, catalog, etc.), date, page(s), volume-issue number(s), publisher, city and/or country where published.	T ¹
	192	2K Digital Cinema Camera Streamlines Movie and HD Production, Silicon Imaging Digital Cinema, Press News Releases, Hollywood, California, date listed November 1, 2006, in 2 pages. (www.siliconimaging.com_DigitalCinema_News_PR_11_01_06_1)	
	193	4:4:4 12-bit Uncompressed DVX100, date listed May 11 - 16, 2004, in 9 pages. (http://www.dvinfo.net/forum/archive/index.php/t-20332-p-13.html)	
	194	Abel Cine, "Abel North American Agent for Phantom Cameras," February 7, 2007, http://web.archive.org/web/20120523003248/http://about.abelcine.com/2007/02/07/abel-north-american-agent-for-phantom-cameras/ in 2 pages.	
	195	ARRIFLEX D-20 Preliminary Specifications, archive.org indicates available on-line on May 31, 2005, www.arri.com , [online], http://web.archive.org/web/20050531010626/www.arri.com/entry/products.htm , pp. 1-2	
	196	ARRIFLEX D-21: The Film Style Digital Camera, date listed January 4, 2008, www.arri.de , [online] http://www.arri.de/press/press/press_release.html?tx_ttnews[tt_news]=32&tx_ttnews[backPid]=1781&cHash=e89c9b0855e89c9b0855	
	197	BRUNER, Guy, Silicon Imaging Shows 1920x1080P Camera System, Camcorder News, Las Vegas, NAB, date listed April 25, 2006, in 8 pages. (http://www.camcorderinfo.com/content/Silicon-Imaging-Shows-1920x1080P-Camera-System.htm)	
	198	CineForm Insider, blog post dated November 13, 2007; http://cineform.blogspot.com/2007/11/cineform-on-chip.html , in 3 pages	
	199	CineForm Insider, date listed as January through December, 2006, in 17 pages. (http://cineform.blogspot.com/search?updated-min=2006-01-01T00:00:00-08:00&updated-max=2007-01-01T00:00:00-08:00&max-results=22)	
	200	CineForm Online Workflow Solutions for Film and Video - November 1, 2006	
	201	CineForm Raw - Dalsa and Vision Research Raw File Converters, printed August 16, 2010, www.cineform.com , [online].	
	202	CineForm RAW - Technology Overview and Workflow, date listed April 13, 2006, in 3 pages.	
	203	CinemaTechnic Camera Profiles ARRI 16SR, date listed 2001	
	204	Dalsa Origin Brochure, document indicates that it was printed April 2004, in 2 pages.	
	205	"Dalsa Technology with Vision," Presentation, March 2003, pp. 35.	
	206	Defendant's Answer, Affirmative Defenses and Counterclaims; Demand for Jury Trial; RED.COM, Inc. v. Sony Corporation of America and Sony Electronics Inc., Case No. 13CV0334-DMS-BGS, dated June 20, 2013.	
	207	Digital Negative (DNG) Specification, date listed April 2008	

Examiner Signature	Date Considered
<p>*Examiner: Initial if reference considered, whether or not citation is in conformance with MPEP 609. Draw line through citation if not in conformance and not considered. Include copy of this form with next communication to applicant.</p>	

T¹ - Place a check mark in this area when an English language Translation is attached.

INFORMATION DISCLOSURE STATEMENT BY APPLICANT	Application No.	14/485612
	Filing Date	September 12, 2014
	First Named Inventor	James H. Jannard
	Art Unit	2661
<i>(Multiple sheets used when necessary)</i>	Examiner	Unknown
SHEET 9 OF 14	Attorney Docket No.	REDCOM.007C4

NON PATENT LITERATURE DOCUMENTS

Examiner Initials	Cite No.	Include name of the author (in CAPITAL LETTERS), title of the article (when appropriate), title of the item (book, magazine, journal, serial, symposium, catalog, etc.), date, page(s), volume-issue number(s), publisher, city and/or country where published.	T ¹
	208	DOUTRE et al., "An Efficient Compression Scheme for Colour Filter Array Images Using Estimated Colour Difference", IEEE Canadian conference on Electrical and Computer Engineering, date listed 2007, pp.24-27	
	209	ION, Lucian, et al., High Dynamic Range Data Centric Workflow System, DALSA Digital Cinema, this paper reported to be originally presented at SMPTE Technical Conference and Exhibit, New York, date listed November 2005, in 14 pages.	
	210	ION, Lucian, et al., White Paper: 4K Digital Capture and Postproduction Workflow, DALSA Digital Cinema, in 5 pages.	
	211	ISO Standard 15444 (part 1): Information technology - JPEG 2000 image coding system: Core coding system, pages i-v, xiv, 1-11,120-122, copyright date listed is 2004.	
	212	JPEG 2000 still image coding versus other standards, date listed July 2000	
	213	LUKAC et al.: Single-sensor camera image compression, date listed May 2006, pages 299-307.	
	214	MENON et al., "On The Dependency Between Compression and Demosaicing In Digital Cinema", Visual Media Production, The 2nd IEEE European Conference, Nov. 30 - Dec. 1, 2005, pp. 104 - 111.	
	215	MITANI, et al.; A 4 K x 2 K-pixel color image pickup system; IEICE Transactions on Information and Systems; E82D (8): 1219-1227; August -1999	
	216	MITANI, et al.; Ultrahigh-definition color video camera system with 4K-scanning lines; Sensors and Camera Systems for Scientific, Industrial, and Digital Photography Applications IV, 5017: 159-166, 2003	
	217	New Camcorder from Silicon Imaging, © 2006-2008 Digital Camcorder News, date listed April 19, 2006, in 2 pages. http://www.digitalcamcordernews.com/2006/04/new-camcorder-from-silicon-imaging)	
	218	NORDHAUSER, Steve, Silicon Imaging Announces World's First Digital Cinema Camera with Direct-to-Disk 10-bit CineForm RAW™ Recording and Adobe® Production Studio Integration, Silicon Imaging, Inc., Albany, New York, date listed June 26, 2006, in 3 pages. (http://www.filmmakers.com/news/digital/article_713.shtml)	
	219	Notes from the field: Silicon Imaging SI-1920HDVR camera in actual use, FRESHDV, date listed May 18, 2006, in 2 pages. (http://www.freshdv.com/2006/05/notes-from-field-silicon-imaging-si.html)	
	220	PHANTOM 65 the world's first 65mm digital cinema, date listed Nov 22, 2006	
	221	PHANTOM 65, archive.org indicates available on-line February 4, 2007, www.visionresearch.com , [online], http://web.archive.org/web/20070204110551/www.visionresearch.com/index.cfm?sector=htm/files&page=camera_65_new , pp. 1-2	
	222	"Phantom HD", < http://www.alfavisionsrl.com.ar/espanol/alquiler/camera/info/manuals/DS_phantomHD.pdf >, dated March 30, 2007, pp. 2.	
	223	Compiled by PUHOVSKI, NENAD, High Definition Report from Cilect Standing Committee for New Technologies, Madrid, date listed 2006, in 146 pages.	

Examiner Signature	Date Considered
--------------------	-----------------

***Examiner:** Initial if reference considered, whether or not citation is in conformance with MPEP 609. Draw line through citation if not in conformance and not considered. Include copy of this form with next communication to applicant.

T¹ - Place a check mark in this area when an English language Translation is attached.

INFORMATION DISCLOSURE STATEMENT BY APPLICANT	Application No.	14/485612
	Filing Date	September 12, 2014
	First Named Inventor	James H. Jannard
	Art Unit	2661
<i>(Multiple sheets used when necessary)</i>	Examiner	Unknown
SHEET 10 OF 14	Attorney Docket No.	REDCOM.007C4

NON PATENT LITERATURE DOCUMENTS			
Examiner Initials	Cite No.	Include name of the author (in CAPITAL LETTERS), title of the article (when appropriate), title of the item (book, magazine, journal, serial, symposium, catalog, etc.), date, page(s), volume-issue number(s), publisher, city and/or country where published.	T ¹
	224	"RED Digital Cinema", < http://www.dvxuser.com/articles/redteam/RED-DVXUSER.pdf >, December 31, 2006, pp. 2.	
	225	"Red Exclusive Brochure", www.dvxuser.com, retrieved on February 5, 2013, in 1 page http://www.dvxuser.com/V6/archive/index.php/t-54786.html	
	226	RED vs DALSA ORIGIN, REDUSER.net, The DSMC System, Red One, date listed October 26, 2007, in 5 pages. (http://www.reduser.net/forum/archive/index.php/t-5344.html)	
	227	ROBIN, Gamma Correction, www.broadcastengineering.com [online], date listed January 1, 2005 in 5 pages.	
	228	NAB2006DayThree, archive.org indicates available on-line March 2, 2007, [on-line] http://web.archive.org/web/20070302002153/http://web.mac.com/mikedcurtis/iWeb/HD4NDs_Image_Galleries/NAB2006DayThreePt1.html , in 5 pages.	
	229	SI-2K Digital Cinema Camera, Silicon Imaging, copyright date listed is 2007, in 14 pages.	
	230	Silicon Imaging SI-2K MINI Full Specifications, archive.org indicates available on-line May 23, 2007, www.siliconimaging.com, [online], http://web.archive.org/web/20070523223217/www.siliconimaging.com/DigitalCinema/SI_2K_full_specifications.html , pp. 1-2	
	231	Silicon Imaging, PRESS News Releases, www.siliconimaging.com/DigitalCinema/SI_Press.html , printed November 5, 2012.	
	232	Silicon Imaging Support: Frequently-Asked-Questions, archive.org indicates available on-line December 12, 2007, www.siliconimaging.com, [online], http://web.archive.org/web/20071212165310/www.siliconimaging.com/DigitalCinema/SiliconImaging_faq.html , in 12 pages.	
	233	SI-1920HDVR Key Features, Silicon Imaging Digital Cinema, in 2 pages. (http://www.siliconimaging.com/DigitalCinema/key_features.html)	
	234	SMITH, et al.; Constant quality JPEG2000 rate control for digital cinema; Source: Proceedings of SPIE - The International Society for Optical Engineering, v 6508, n PART 1, 2007, Conference: Visual Communications and Image Processing 2007, January 30, 2007 - February 1, 2007	
	235	SMITH, et al., Image Resolution of the One-CCD Palomar Motion Picture Camera, 37th Advance Motion Imaging Conference, Seattle, Washington, date listed February 27-March 1, 2003, in 8 pages.	
	236	Some Like It Raw, Silicon Imaging D-Cinema Camera with Cineform RAW Codec, Studio Daily, date listed May 8, 2006, [on-line] http://www.studiodaily.com/2006/05/some-like-it-raw/	
	237	THE RED ONE CAMERA 4K Resolution, various dates listed, starting from February 7th, 2007, URL: http://www.vnnforum.com/showthread.php?t=44489 [retrieved on 2012-08-03]	
	238	WILT, Adam, Camera Log, NAB 2009 - SI-2K, date listed April 19, 2009, in 5 pages. (http://videocoalition.com/index.php/awilt/story/nab_2009_si_2k/)	
	239	ZENG, Jianfen, et al., Video Coding Techniques for Digital Cinema, ©2004 IEEE International Conference on Multimedia and Expo (ICME), pages 415-418, Vol. 1.	

Examiner Signature	Date Considered
<p>*Examiner: Initial if reference considered, whether or not citation is in conformance with MPEP 609. Draw line through citation if not in conformance and not considered. Include copy of this form with next communication to applicant.</p>	

T¹ - Place a check mark in this area when an English language Translation is attached.

INFORMATION DISCLOSURE STATEMENT BY APPLICANT	Application No.	14/485612
	Filing Date	September 12, 2014
	First Named Inventor	James H. Jannard
	Art Unit	2661
<i>(Multiple sheets used when necessary)</i>	Examiner	Unknown
SHEET 11 OF 14	Attorney Docket No.	REDCOM.007C4

NON PATENT LITERATURE DOCUMENTS

Examiner Initials	Cite No.	Include name of the author (in CAPITAL LETTERS), title of the article (when appropriate), title of the item (book, magazine, journal, serial, symposium, catalog, etc.), date, page(s), volume-issue number(s), publisher, city and/or country where published.	T ¹
	240	ZHANG et al. Real-time lossless compression of mosaic video sequences, Zhang, L; Wu, X; Bao, P, date listed 10 August 2005, in 8 pages	
	241	Complaint for Patent Infringement; RED.COM, INC., Inc. v. Sony Corporation of America and Sony Electronics, Inc., U.S. District Court for the Southern District of California, Case No.: 3:13-cv-00334-DMS-BGS, dated February 12, 2013.	
	242	Joint Motion for Dismissal Without Prejudice; RED.COM, Inc. v. Sony Corporation of America and Sony Electronics Inc., Case No. 13CV0334-DMS-BGS, dated July 19, 2013.	
	243	On-line discussion thread from www.dvxuser.com, first post in thread dated May 1, 2006, retrieved from http://www.dvxuser.com/V6/showthread.php?55590-Worried-about-depending-on-RED-codec	
	244	On-line discussion thread from www.dvxuser.com, first post in thread dated September 8, 2006, retrieved from http://www.dvxuser.com/V6/showthread.php?70333-Workflow-(good)-News	
	245	On-line discussion thread from www.dvxuser.com, first post in thread dated September 8, 2006, retrieved from http://www.dvxuser.com/V6/showthread.php?70412-First-video-from-the-RED-4K-demo!	
	246	On-line discussion thread from www.dvxuser.com, first post in thread dated September 8, 2006, retrieved from http://www.dvxuser.com/V6/showthread.php?70417-RED-workflow-(how-we-prepared-the-Red-Footage-for-IBC)	
	247	On-line discussion thread from www.dvxuser.com, first post in thread dated September 10, 2006, retrieved from http://www.dvxuser.com/V6/showthread.php?70671-4K-RAW-data-rates	
	248	On-line discussion thread from www.dvxuser.com, first post in thread dated September 18, 2006, retrieved from http://www.dvxuser.com/V6/showthread.php?71703-Dynamic-Range	
	249	On-line discussion thread from www.dvxuser.com, first post in thread dated September 19, 2006, retrieved from http://www.dvxuser.com/V6/showthread.php?71756-RED-code-RAW-lossless-lossy	
	250	On-line discussion thread from www.dvxuser.com, first post in thread dated September 24, 2006, retrieved from http://www.dvxuser.com/V6/showthread.php?72306-4k-live-(-4k-Still-from-Red-One-is-up-)	
	251	On-line discussion thread from www.dvxuser.com, first post in thread dated October 2, 2006, retrieved from http://www.dvxuser.com/V6/showthread.php?73415-1st-video-posted	
	252	On-line discussion thread from www.dvxuser.com, first post in thread dated October 3, 2006, retrieved from http://www.dvxuser.com/V6/showthread.php?73448-editing-4K-at-home	
	253	On-line discussion thread from www.dvxuser.com, first post in thread dated October 9, 2006, retrieved from http://www.dvxuser.com/V6/showthread.php?74232-1k-Bubble-Girl-video-up	
	254	On-line discussion thread from www.dvxuser.com, first post in thread dated October 31, 2006, retrieved from http://www.dvxuser.com/V6/showthread.php?76711-First-REDCODE-image!	

Examiner Signature	Date Considered
<p>*Examiner: Initial if reference considered, whether or not citation is in conformance with MPEP 609. Draw line through citation if not in conformance and not considered. Include copy of this form with next communication to applicant.</p>	

T¹ - Place a check mark in this area when an English language Translation is attached.

INFORMATION DISCLOSURE STATEMENT BY APPLICANT	Application No.	14/485612
	Filing Date	September 12, 2014
	First Named Inventor	James H. Jannard
	Art Unit	2661
<i>(Multiple sheets used when necessary)</i>	Examiner	Unknown
SHEET 12 OF 14	Attorney Docket No.	REDCOM.007C4

NON PATENT LITERATURE DOCUMENTS

Examiner Initials	Cite No.	Include name of the author (in CAPITAL LETTERS), title of the article (when appropriate), title of the item (book, magazine, journal, serial, symposium, catalog, etc.), date, page(s), volume-issue number(s), publisher, city and/or country where published.	T ¹
	255	On-line discussion thread from www.dvxuser.com, first post in thread dated November 3, 2006, retrieved from http://www.dvxuser.com/V6/showthread.php?76954-Red-still-gallery-updated-with-new-4k-still!	
	256	On-line discussion thread from www.dvxuser.com, first post in thread dated November 4, 2006, retrieved from http://www.dvxuser.com/V6/showthread.php?77032-RAW-vs-REDCODE-RAW	
	257	On-line discussion thread from www.dvxuser.com, first post in thread dated November 5, 2006, retrieved from http://www.dvxuser.com/V6/showthread.php?77117-Slo-Mo-and-REDCODE-RAW-questions	
	258	On-line discussion thread from www.dvxuser.com, first post in thread dated November 6, 2006, retrieved from http://www.dvxuser.com/V6/showthread.php?77216-120fps-at-4K	
	259	On-line discussion thread from www.dvxuser.com, first post in thread dated November 13, 2006, retrieved from http://www.dvxuser.com/V6/showthread.php?78010-David-Stump-on-Red	
	260	On-line discussion thread from www.dvxuser.com, first post in thread dated November 14, 2006, retrieved from http://www.dvxuser.com/V6/showthread.php?78150-RED-L-A-photos-what-have-you-s	
	261	On-line discussion thread from www.dvxuser.com, first post in thread dated November 15, 2006, retrieved from http://www.dvxuser.com/V6/showthread.php?78290-Red-Camera-first-test-with-Still-Lens-(-Nikon-)	
	262	On-line discussion thread from www.dvxuser.com, first post in thread dated November 19, 2006, retrieved from http://www.dvxuser.com/V6/showthread.php?78623-Red-compression-and-matrix-tests	
	263	On-line discussion thread from www.dvxuser.com, first post in thread dated November 20, 2006, retrieved from http://www.dvxuser.com/V6/showthread.php?78823-Image-links-fixed	
	264	On-line discussion thread from www.dvxuser.com, first post in thread dated November 21, 2006, retrieved from http://www.dvxuser.com/V6/showthread.php?78934-redcode-amazingly-good-!	
	265	On-line discussion thread from www.dvxuser.com, first post in thread dated November 24, 2006, retrieved from http://www.dvxuser.com/V6/showthread.php?79130-More-footage	
	266	On-line discussion thread from www.dvxuser.com, first post in thread dated December 11, 2006, retrieved from http://www.dvxuser.com/V6/showthread.php?80963-NEW-VIDEO!!!-Bus-Video-1080p-clip-online-REDCODE	
	267	On-line discussion thread from www.dvxuser.com, first post in thread dated December 18, 2006, retrieved from http://www.dvxuser.com/V6/showthread.php?81686-Specs-changes	
	268	On-line discussion thread from www.hdforindies.com, first post in thread dated September 8, 2006, retrieved from http://www.hdforindies.com/2006/09/amsterdam-ibc-2006-red-news-redcode-4k.html	
	269	On-line discussion thread from www.hdforindies.com, first post in thread dated December 19, 2006, retrieved from http://www.hdforindies.com/2006/12/mikes-conjecture-on-redcode-data-rates.html	

Examiner Signature	Date Considered
<p>*Examiner: Initial if reference considered, whether or not citation is in conformance with MPEP 609. Draw line through citation if not in conformance and not considered. Include copy of this form with next communication to applicant.</p>	

T¹ - Place a check mark in this area when an English language Translation is attached.

INFORMATION DISCLOSURE STATEMENT BY APPLICANT	Application No.	14/485612
	Filing Date	September 12, 2014
	First Named Inventor	James H. Jannard
	Art Unit	2661
<i>(Multiple sheets used when necessary)</i>	Examiner	Unknown
SHEET 13 OF 14	Attorney Docket No.	REDCOM.007C4

NON PATENT LITERATURE DOCUMENTS

Examiner Initials	Cite No.	Include name of the author (in CAPITAL LETTERS), title of the article (when appropriate), title of the item (book, magazine, journal, serial, symposium, catalog, etc.), date, page(s), volume-issue number(s), publisher, city and/or country where published.	T ¹
	270	Order Granting Joint Motion for Dismissal Without Prejudice; RED.COM, Inc. v. Sony Corporation of America and Sony Electronics Inc., Case No. 13CV0334-DMS-BGS, dated July 29, 2013.	
	271	RED DIGITAL CINEMA, "Introducing REDCODE", September 2006, International Broadcasting Convention, Amsterdam, the Netherlands, in 1 page.	
	272	RED DIGITAL CINEMA, "Mysterium Sensor", September 2006, International Broadcasting Convention, Amsterdam, the Netherlands, in 1 page.	
	273	RED DIGITAL CINEMA, "Preliminary Specifications", September 2006, International Broadcasting Convention, Amsterdam, the Netherlands, in 1 page.	
	274	RED DIGITAL CINEMA, "Preliminary Specifications", April 14-19, 2007, Las Vegas, Nevada, in 1 page.	
	275	RED DIGITAL CINEMA, "Simple. 4K to Anything", September 2006, International Broadcasting Convention, Amsterdam, the Netherlands, in 1 page.	
	276	Request for Re-Examination of U.S. Patent No. 8,174,560 (REDCOM.007A), dated September 13, 2012.	
	277	Re-Examination Grant in U.S. Patent No. 8,174,560 (REDCOM.007A), dated December 6, 2012.	
	278	Official Communication in Japanese Application No. 2012-506053 (REDCOM.007QJP), dated October 16, 2013.	
	279	International Search Report and Written Opinion in PCT Application No. PCT/US2010/028808 (REDCOM.007QPC), dated August 3, 2010.	
	280	Examination Report in Australian Application No. 2008240144 (REDCOM.007VAU), dated December 23, 2010.	
	281	Official Communication in Chinese Application No. 200880018570.6 (REDCOM.007VCN), dated March 31, 2014.	
	282	Official Communication in European Application No. 08745686.9 (REDCOM.007VEP), dated March 30, 2010.	
	283	Extended European Search Report in European Application No. 08745686.9 (REDCOM.007VEP), dated August 4, 2011.	
	284	Office Action in European Application No. 08745686.9 (REDCOM.007VEP), dated August 10, 2012.	
	285	Summons to Attend Oral Proceedings in European Application No. 08745686.9 (REDCOM.007VEP), dated October 31, 2013.	
	286	Official Communication in European Application No. 08745686.9 (REDCOM.007VEP), dated February 5, 2014.	
	287	Official Communication in European Application No. 08745686.9 (REDCOM.007VEP), dated March 18, 2014.	
	288	Office Action in Mexican Application No. MX/a/2009/010926 (REDCOM.007VMX), dated May 16, 2012.	

Examiner Signature	Date Considered
<p>*Examiner: Initial if reference considered, whether or not citation is in conformance with MPEP 609. Draw line through citation if not in conformance and not considered. Include copy of this form with next communication to applicant.</p>	

T¹ - Place a check mark in this area when an English language Translation is attached.

INFORMATION DISCLOSURE STATEMENT BY APPLICANT	Application No.	14/485612
	Filing Date	September 12, 2014
	First Named Inventor	James H. Jannard
	Art Unit	2661
<i>(Multiple sheets used when necessary)</i>	Examiner	Unknown
SHEET 14 OF 14	Attorney Docket No.	REDCOM.007C4

NON PATENT LITERATURE DOCUMENTS			
Examiner Initials	Cite No.	Include name of the author (in CAPITAL LETTERS), title of the article (when appropriate), title of the item (book, magazine, journal, serial, symposium, catalog, etc.), date, page(s), volume-issue number(s), publisher, city and/or country where published.	T ¹
	289	Office Action in Japanese Application No. 2010-503253 (REDCOM.007VJP), dated June 26, 2012.	
	290	Office Action in Korean Application No. 10-2009-7023045 (REDCOM.007VKR), dated February 6, 2014.	
	291	Examination Report in New Zealand Application No. 580171 (REDCOM.007VNZ), dated February 22, 2011.	
	292	Examination Report in New Zealand Application No. 601474 (REDCOM.007NZD1), dated August 1, 2012.	
	293	Examination Report in New Zealand Application No. 620333 (REDCOM.007NZD2), dated February 14, 2014.	
	294	Written Opinion in PCT Application No. PCT/US2008/060126 (REDCOM.007VPC), dated July 7, 2008.	
	295	International Preliminary Report on Patentability in PCT Application No. PCT/US2008/060126 (REDCOM.007VPC), dated October 13, 2009	
	296	Official Communication in Taiwanese Application No. 097113289 (REDCOM.007VTW), dated August 29, 2013	
	297	Final Office Action in Re-Examination of US Patent No. 8,174,560 (REDCOM.007X1), dated October 31, 2013.	
	298	Notice of Intent to Issue Ex Parte Reexamination Certificate in Re-Examination of US Patent No. 8,174,560 (REDCOM.007X1), dated March 5, 2014.	
	299	International Search Report and Written Opinion in PCT Application No. PCT/US2010/060851 (REDCOM.032WO), dated August 24, 2011.	
	300	International Search Report and Written Opinion in PCT Application No. PCT/US2014/016301 (REDCOM.084WO), dated May 21, 2014.	
	301	Official Communication in Taiwanese Application No. 097113289 (REDCOM.007VTW), dated July 15, 2014	
	302	Official Communication in European Application No. 14177071.9 (REDCOM.007VEPD1), dated August 22, 2014.	
	303	Examination Report in Australian Application No. 2012216606 (REDCOM.007VAUD1), dated July 31, 2014.	
	304	Official Communication in European Application No. 10726688.4 (REDCOM.007QEP), dated July 14, 2014.	
	305	POYNTON, Charles, "A Technical Introduction to Digital Video," 1996, Ch. 6 (Gamma), pp. 91-114.	

18876617

Examiner Signature	Date Considered
<p>*Examiner: Initial if reference considered, whether or not citation is in conformance with MPEP 609. Draw line through citation if not in conformance and not considered. Include copy of this form with next communication to applicant.</p>	

T¹ - Place a check mark in this area when an English language Translation is attached.



INTERNATIONAL APPLICATION PUBLISHED UNDER THE PATENT COOPERATION TREATY (PCT)

<p>(51) International Patent Classification ⁵ : H04N 11/04, 7/133, 9/04</p>	<p>A1</p>	<p>(11) International Publication Number: WO 92/10911 (43) International Publication Date: 25 June 1992 (25.06.92)</p>
<p>(21) International Application Number: PCT/US91/08767 (22) International Filing Date: 26 November 1991 (26.11.91) (30) Priority data: 625,232 10 December 1990 (10.12.90) US (71) Applicant: EASTMAN KODAK COMPANY [US/US]; 343 State Street, Rochester, NY 14650-2201 (US). (72) Inventors: TSAI, Yusheng, Timothy ; 269 North Creek Crossing, Rochester, NY 14612 (US), DALY, Scott, James ; 1758 Scottsville-Mumford Road, Scottsville, NY 14546 (US). (74) Agent: DUGAS, Edward; 343 State Street, Rochester, NY 14650-2201 (US).</p>		<p>(81) Designated States: AT (European patent), BE (European patent), CH (European patent), DE (European patent), DK (European patent), ES (European patent), FR (European patent), GB (European patent), GR (European patent), IT (European patent), JP, LU (European patent), NL (European patent), SE (European patent). Published With international search report.</p>

(54) Title: IMAGE COMPRESSION WITH COLOR INTERPOLATION FOR A SINGLE SENSOR IMAGE SYSTEM

(57) Abstract

In accordance with the present invention, the R, G, B color image signals from a single sensor having a color filter array are all transformed to Γ -space by changing them to $R^{1/\Gamma}$, $G^{1/\Gamma}$, $B^{1/\Gamma}$, respectively, where Γ is approximately 2.4. In this space, all operations such as color differencing, interpolation of those missing pixels required for color differencing, compression, decompression, edge enhancement and final interpolation of all missing pixels are performed without further transformation of the image signals. For the same final bit rate, noise in the reproduced image is reduced by refraining from

interpolating the missing color pixels prior to compression of the image data. In order to avoid over-emphasizing features of the image which are already sufficiently sharp, the combined outputs of horizontal and vertical sharpening processes are subjected to a paring process of the invention which suppresses strong high-spatial frequency components as a function of their amplitude. In the compression-decompression process of the invention, each spatial frequency coefficient of the spatial frequency-transformed image is divided by a normalization factor determined by cascading in the spatial frequency domain the human visual system contrast sensitivity function, the edge enhancement modulation transfer function and the image display modulation transfer function and inverting the resulting matrix elements.

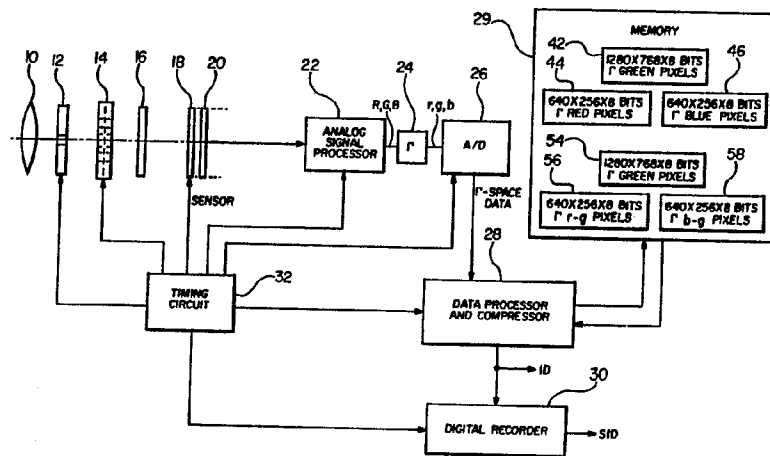

FOR THE PURPOSES OF INFORMATION ONLY

Codes used to identify States party to the PCT on the front pages of pamphlets publishing international applications under the PCT.

AT	Austria	ES	Spain	MG	Madagascar
AU	Australia	FI	Finland	ML	Mali
BB	Barbados	FR	France	MN	Mongolia
BE	Belgium	GA	Gabon	MR	Mauritania
BF	Burkina Faso	GB	United Kingdom	MW	Malawi
BG	Bulgaria	GN	Guinea	NL	Netherlands
BJ	Benin	GR	Greece	NO	Norway
BR	Brazil	HU	Hungary	PL	Poland
CA	Canada	IT	Italy	RO	Romania
CF	Central African Republic	JP	Japan	SD	Sudan
CG	Congo	KP	Democratic People's Republic of Korea	SE	Sweden
CH	Switzerland	KR	Republic of Korea	SN	Senegal
CJ	Côte d'Ivoire	LI	Liechtenstein	SU ⁺	Soviet Union
CM	Cameroon	LK	Sri Lanka	TD	Chad
CS	Czechoslovakia	LU	Luxembourg	TG	Togo
DE*	Germany	MC	Monaco	US	United States of America
DK	Denmark				

+ Any designation of "SU" has effect in the Russian Federation. It is not yet known whether any such designation has effect in other States of the former Soviet Union.

**IMAGE COMPRESSION WITH COLOR INTERPOLATION
FOR A SINGLE SENSOR IMAGE SYSTEM**

BACKGROUND OF THE INVENTION

5 Technical Field:

The field of the invention is compression of a color image signal --such as that generated by a single sensor 3-color filter array-- whose chrominance-related (e.g., blue and red) components are sub-sampled with respect to 10 its luminance-related (e.g., green) component.

Background Art:

Electronic color cameras which employ only a single sensor are highly economical compared with electronic 15 color cameras employing three separate sensors (e.g., red, green and blue sensors). A single image sensor (such as a CCD imager integrated circuit) can be made to produce a color image signal simply by imposing a color filter array over the sensor. The color filter array 20 permits light of different colors to impinge on different picture elements (pixels) of the sensor in a fixed predetermined pattern. Typically one of the three colors (usually green) is most closely related to the luminance component of the image while the remaining two colors 25 (usually red and blue) are most closely related to the chrominance components of the image. Using a single sensor necessarily reduces the resolution of each color component of the image, because sensor pixels dedicated to one color are in effect "missing" with respect to the 30 other colors. Such "missing" pixels for a given color must therefore be inferred by interpolation in the reproduced image. Such interpolation can introduce into the reproduced image distortion objectionably visible to the human eye. The human eye is most sensitive to the 35 luminance component of such distortion.

In order to minimize the perception of such distortion by the human eye and provide the most pleasing reproduced image, the resolution (or pixel density) of the luminance-related (e.g., green) pixels is increased at the expense of the chrominance-related (e.g., red and blue) pixels. Specifically, the color pattern of the color filter array is such that a majority of the sensor pixels receive the luminance-related (green) component of the light, while the remaining pixels receive the chrominance-related colors (e.g., red and blue). For example, a well-known color filter array (referred to as a 3G color filter array) consists of three rows of green pixels followed by a row of alternating red and blue pixels, so that $3/4$ of the pixels are green and the blue and red pixels each comprise $1/8$ of the pixels.

In reproducing a color image from the signal generated by the image sensor and color filter array combination and computing the missing chrominance-related pixels, the distortion perceived by the human eye is further reduced by interpolating between the ratios of the chrominance-related (red and blue) pixels to the co-located green pixels. This approach succeeds in reducing the distortion detected by the human eye because it can be shown that it reduces the luminance component of the distortion (without necessarily reducing the overall distortion).

A further improvement is achieved by performing such color interpolation of intensity values using the logarithm of each pixel intensity rather than the pixel intensity itself. This feature improves the color fidelity in the reproduced image because of the non-linear relationships involved in combining color signals,

which are well-known and need not be described herein. One advantage is that this feature permits interpolation of color difference signals rather than ratios, since, for example,

5 $\log R/G = \log R - \log G$
 and $\log B/G = \log B - \log G$.

All of the foregoing color image signal processing methods are described in U.S. Patent Application Serial
10 No. 384,353 filed 24 July 1989 by Yusheng T. Tsai, Kenneth A. Parulski and Majid Rabbani entitled "A COMPRESSION METHOD AND APPARATUS FOR SINGLE SENSOR COLOR IMAGING SYSTEMS" and assigned to the assignee of the present invention. The referenced application describes
15 how to employ such methods in an image compression system. In the referenced patent application, compression prior to interpolation of the missing pixels is disclosed. In the image compression system, the amount by which digital data representing each spatial
20 frequency component of the image signal is compressed is varied so as to compensate for the contrast sensitivity function of the human eye, as described in U.S. Patent No. 4,780,761 to Scott J. Daly et al. and assigned to the assignee of the present invention.

25

The green signal is preferably interpolated linearly because the green signal is the one most closely related to the luminance component. One problem with the foregoing techniques is that the red, green and blue
30 signals must be transformed to logarithms in order to best interpolate the color difference signals. This ultimately requires a multiplicity of such transformations, representing a significant processing burden.

35

Another problem is that image processing, such as sharpening or edge enhancement, can increase the visibility of distortions introduced into the reproduced image by the compression-decompression process. A

5 related problem is that the modulation transfer function introduced by the image display (such as a color video monitor or color paper printing) can affect the visibility of distortions introduced into the image by the compression-decompression process.

10

Still another problem is that the human eye contrast sensitivity function has a lower frequency response to the color difference signals than to the luminance-related green signal. While the prior art teaches sub-
15 sampling color pixels with respect to luminance pixels to accommodate for this aspect of the human visual system, a better method is needed. This is particularly true in the case of the 3G color filter array, in which sub-sampling of the red and blue pixels is non-isotropic,
20 being two times greater along the columns of the array than along the rows of the array.

Yet another problem is that such edge enhancement processes tend to objectionably over-emphasize image
25 features which are already sufficiently sharp. It has seemed that this is an unavoidable penalty which accompanies edge enhancement of the image. Therefore, there is a need for an edge enhancement process which does not over-emphasize sufficiently sharp image
30 features. A related problem is that a CCD image sensor introduces CCD charge transfer noise into its output signal in a non-isotropic manner which affects high spatial frequency texture or edge features lying along one axis of the image more than those lying along the

35

other axis of the image. Edge enhancement tends to emphasize such noise.

Accordingly, it is an object of the invention to
5 reproduce an image from a single sensor/color filter array combination without requiring any logarithmic transformations whatsoever.

It is a further object of the invention to perform
10 all processing and compression of all components of the image signal in the same color space, thereby minimizing the number of required transformations.

It is another object of the invention to
15 automatically compensate for the effects of the edge enhancement process and of the image display on the visibility of errors introduced by the compression/decompression image process.

It is still another object of the invention to
20 provide different adaptive corrections in the compression-decompression processes for different (luminance-related and chrominance-related) components of the image best suited for the respective components.

25

It is a still further object of the invention to provide different adaptive corrections in the compression-decompression processes for different components of the image in accordance with the lower
30 frequency response of the human visual system to the color difference signals and in accordance with the non-isotropic pattern of the green, red and blue pixels of the color filter array.

35

It is yet another object of the invention to provide an edge enhancement process which does not over-emphasize image features which are already sufficiently sharp and which does not require any transformation of the image data to another color space (e.g., a log or anti-log transformation). It is a related object of the invention to provide such an edge enhancement process which refrains from emphasizing CCD transfer noise affecting high spatial frequency image features along one axis without detracting from the edge enhancement of features lying along the other axis of the image.

DISCLOSURE OF THE INVENTION

In accordance with the present invention, the color pixel amplitudes from a single sensor having a color filter array are all transformed to Γ -space by raising them to the power of $1/\Gamma$, respectively, where Γ is approximately 2.4. For example, if the color filter array provides red, green and blue (R,G,B) color pixel amplitudes, then the transformation provides the following Γ -space color signals: $R^{1/\Gamma}$, $G^{1/\Gamma}$, $B^{1/\Gamma}$. All operations such as color differencing, interpolation of those missing pixels required for color differencing, compression/decompression, edge enhancement and final interpolation of all missing pixels are performed in Γ -space without further transformation of the image signals. (This transformation has been used in other applications to achieve more faithful reproduction and less visible quantization noise in comparison with other methods which used the logarithm of the luminance, as described in "Uniform Perceptual Quantization: Applications to Digital Radiography" by Sezan, Yip and Daly, IEEE Trans. Sys. Man. Cyber. Vol. SNC-17 #4 1987 622-634.) The advantage realized in the present invention is the elimination of unnecessary

transformation steps, so that the entire signal process is greatly simplified by performing every step in Γ -space and sources of error are reduced. In the preferred embodiment of the invention, the uninterpolated Γ -space
5 image data is compressed for recording, storage or transmission and is later decompressed before the missing pixels are inferred by interpolation.

In the edge enhancement or image sharpening process
10 of the invention, the Γ -space luminance-related signal (the green signal in the case of an RGB color signal) is sharpened by emphasizing high-spatial frequency image components along the vertical and horizontal axes independently without transforming the signal to another
15 space. In order to avoid over-emphasizing high-spatial frequency image components which are unreliable or noisy due to the non-isotropic manner in which CCD transfer noise is introduced into the sensor output signal, a transversal blur or low-pass filter is imposed on the
20 output of the vertical axis sharpening process before it is combined with the output of the horizontal axis sharpening process. In order to avoid over-sharpening features of the image which are already sufficiently sharp, the combined outputs of the horizontal and
25 vertical sharpening processes are subjected to a paring process of the invention which suppresses strong high spatial frequency components as a function of their amplitude.

30 The invention compensates for the effects of the modulation transfer function of the edge enhancement process and the color image display device or media on the visibility of distortions introduced by the data compression process. This compensation is achieved in
35 the data compression process, which requires that the

image data be divided into blocks and each block be transformed to a block of spatial frequency coefficients. In accordance with the invention, the bit resolution of each spatial frequency coefficient is determined by
5 dividing the coefficient by a corresponding normalization factor taken from an array of normalization factors. The array of normalization factors is determined by (in effect) cascading in the spatial frequency domain the human visual system contrast sensitivity function, an
10 edge enhancement modulation transfer function and an image display modulation transfer function and inverting each element in the resulting cascaded transfer function to its reciprocal.

15 Preferably, the human visual contrast sensitivity function, the edge enhancement modulation transfer function and the display modulation transfer function each comprise an array of spatial frequency domain amplitude elements corresponding to a block of spatial
20 frequency coefficients of the image data. The arrays thus formed are then cascaded. This is accomplished in a progressive manner by first determining from the parameters of position-to-spatial frequency transformation the number of cycles per block of each
25 spatial frequency coefficient in the block. Next, the number of cycles per pixel is determined from the number of pixels per block for each spatial frequency coefficient in the block. This information is used to construct a corresponding array representing the edge
30 enhancement modulation transfer function. Next, the number of cycles per unit distance is determined from the pixel spacing of the display for each spatial frequency coefficient in the block. This information is used to construct a corresponding array representing the image
35 display or media modulation transfer function. Finally,

the number of cycles per degree of visual scan is determined from the viewing distance characteristic of the display for each spatial frequency coefficient in the block. This information is used in the manner described
5 in the above-referenced U.S. Patent No. 4,780,761 to Scott J. Daly et al. to construct a corresponding array representing the human visual contrast sensitivity function.

10 In accordance with a further aspect of the invention, the bandwidth of the human visual contrast sensitivity function is reduced for the color difference (R-G and B-G) signals in computing the normalization factors discussed immediately above. The advantage of
15 this aspect of the invention is that it accommodates the reduced spatial frequency response of the human visual system to the color difference signals R-G and B-G. The normalization arrays thus generated for the R-G and B-G data blocks for the data compression process differ from
20 the normalization array for the G data block in that they have a reduced frequency response and are non-isotropic due to the uneven distribution of red and blue pixels in the 3G color filter array. In the preferred embodiment, a further distinction of the R-G and B-G normalization
25 arrays is that no compensation is made for the edge enhancement and image display modulation transfer functions.

All of the foregoing operations are performed on R-
30 space R, G and B data without any intervening transformations.

BRIEF DESCRIPTION OF THE DRAWINGS

The invention is described below in detail by
35 reference to the accompanying drawings, of which:

Fig. 1 is a block diagram of an image recording system embodying one aspect of the invention;

5 Fig. 2 is a block diagram of an image playback system embodying another aspect of the invention;

Fig. 3 is a block diagram of the color image sensing apparatus employed in the system of Fig. 1;

10

Fig. 4 is a graph of the Γ -space transformation employed in the invention;

15 Fig. 5 is a flow diagram illustrating the image recording process performed by the system of Fig. 1;

Fig. 6 is a flow diagram illustrating the image playback process performed by the system of Fig. 2;

20 Fig. 7 is a block diagram depicting the three interpolated color data blocks produced by the process of Fig. 6;

25 ~~Fig. 8 is a block diagram illustrating the edge enhancement process and playback image processes performed by the system of Fig. 2;~~

30 Fig. 9 is a graph illustrating the response of a paring filter in the edge enhancement circuit of Fig. 8;

Fig.'s 10a and 10b illustrate the data compression and data decompression processes performed by the systems of Fig.'s 1 and 2, respectively;

Fig. 11 illustrates the spatial frequency transformation process performed by the data compressor of Fig. 10a in accordance with the present invention;

5 Fig. 12 illustrates the cascading of the human visual contrast sensitivity function with modulation transfer functions of the edge enhancement process and of the image display in generating the normalization arrays employed in the data compression process of Fig. 10a and
10 in the decompression process of Fig. 10b;

Fig.'s 13a, 13b, 13c and 13d illustrate arrays representing, respectively, the edge enhancement modulation transfer function, the display modulation
15 transfer function, the human visual contrast sensitivity function and an array formed by cascading the foregoing arrays;

Fig.'s 14a and 14b illustrate, respectively, the
20 normalization factor array obtained from the cascaded array of Fig. 13d and a normalization array obtained from the contrast sensitivity function array of Fig. 13c alone; and

25 Fig.'s 15a and 15b illustrate the contrast sensitivity functions for generating the normalization arrays for the R-G image data blocks and the B-G image data blocks, respectively.

30 MODES FOR CARRYING OUT THE INVENTION

Referring to Fig. 1, an image capture or recording system embodying one aspect of the invention receives a light beam from a scene through a lens 10, an aperture 12 and a shutter 14. A blur filter 16 distributes the image
35 in a nearly uniform manner across the image plane of a

color filter array (CFA) 18 and an image sensor 20. The image sensor 20 may be a charge coupled device (CCD) of the type well-known in the art which produces an analog voltage for each one of an array of pixels in its image
5 plane. The CFA 18 preferably is an array of red, green and blue filters overlying respective ones of the pixels of the sensor 20, so that the voltages produced by the sensor 20 represent R, G and B (red, green and blue) light intensity analog signals. The R, G and B analog
10 image signals produced by the sensor 20 are amplified and processed by a conventional analog signal processor 22. The R, G and B analog signals are then transformed by raising them to the exponential power of $1/\Gamma$ in a conventional manner by a non-linear amplifier 24, to
15 produce Γ -space analog image signals $r=R^{1/\Gamma}$, $g=G^{1/\Gamma}$, $b=B^{1/\Gamma}$. The r, g and b Γ -space analog signals are then converted to digital r, g and b data (e.g., 8-bit bytes) by an analog-to-digital converter 26. A data processor and compressor 28 temporarily stores the data in a memory
20 29 and then compresses the data. A digital recorder 30 records the compressed data on a digital storage medium such as a disk. The foregoing components are controlled by a conventional timing circuit 32.

25 Referring to Fig. 2, an image playback or reproducing system embodying another aspect of the invention includes a digital playback device 34 (such as a disk player or digital memory read-out) and a data decompressor and processor 35. The digital playback
30 device 34 receives either the stored image data SID recorded in the digital recorder 30 of Fig. 1 or receives image data ID directly from the data processor and compressor 28 of Fig. 1. The output of the decompressor 35 may be transmitted either to a video display processor
35 36 or to a hardcopy print processor 37. The output of

the video processor 36 is transmitted to a color video display 38 while the output of the print processor 37 is transmitted to a hardcopy color printer 39.

5 Fig. 3 illustrates the preferred apparatus for capturing the image. The CFA 18 is a "3G" CFA of the well-known type comprising 1024 rows and 1280 columns of discrete color filter pixels in which every fourth color filter pixel row contains alternate red and blue pixels
10 while the remaining color filter pixels are green. The R, G and B pixels are in precise registration with respective light sensitive pixels 20A of the sensor 20. The sensor 20 likewise comprises 1024 rows and 1280 columns of light sensitive pixels 20A. If the A/D
15 converter 26 of Fig. 1 produces 8-bit bytes, then 1024 rows and 1280 columns of 8-bit pixels represent the image captured by the sensor 20. However, it should be understood that the number of pixel rows and pixel columns, the number of bits per pixel and the particular
20 color pattern of the CFA 18 are all design choices which may be varied in practicing the invention.

Transformation of the Image Signals to Γ -Space:

Fig. 4 illustrates the behavior of the
25 Γ -transformation from an intensity I to an intensity $I^{1/\Gamma}$. Fig. 4 also illustrates the log-transformation from I to $\log I$ for a pixel intensity I employed in the system of the patent application by Kenneth G. Parulski et al. referenced above. The Γ -transformation is
30 somewhat more nearly linear than the log-transformation and it so happens to provide a superior result when combining or interpolating color difference signals. The main advantage of the Γ -space transformation discovered in the present invention, as will be described
35 hereinbelow, is that no further transformations are

required in processing the image signals, and all image signals (green, red and blue) are processed in the same color space (i.e., Γ -space), providing a significant economy of signal processing and computation.

5

Fig. 5 is a flow diagram depicting successive steps of the process performed by the data processor and compressor 28 of Fig. 1. The data processor 28 receives the Γ -space image data from the A/D converter 26 representing the image captured by the image sensor 20 (step 40 of Fig. 5). In step 41 of Fig. 5, the data processor 28 temporarily stores the data in the memory 29 in three separate memory blocks or color data planes (depicted in Fig. 1) comprising a data plane or memory block 42 of g (Γ -space green) pixels, a data plane or memory block 44 of r (Γ -space red) pixels and a data plane or memory block 46 of b (Γ -space blue) pixels. In the preferred embodiment, the g pixel memory block 42 has 1280 columns by 768 rows of 8-bit bytes, while each one of the b pixel and r pixel blocks 44 and 46 has 640 columns by 256 rows of 8-bit bytes.

10
15
20

Compression Noise Reduction by Refraining from Filling In Certain Missing Pixels:

In each pixel column of the image captured by the image sensor 20, every fourth green pixel is missing (as shown in Fig. 3), so that the missing green pixels must be filled in by vertical interpolation. In alternate pixel columns of the captured image, only every fourth red pixel is present at the site of a missing green pixel. In the remaining columns of the captured image, only every fourth blue pixel is present. Therefore, the red and blue pixels must be interpolated both horizontally and vertically to fill in the missing red and blue pixels. However, it is a discovery of the

25
30
35

invention that by refraining from filling in the missing pixels until after the image has been compressed, recorded, played back and then decompressed, noise in the reproduced image is significantly decreased in comparison
5 with the alternative method in which the missing pixels are filled in prior to compression and recording. This discovery may be confirmed analytically in accordance with statistical methods.

10 In the case of the green image, the missing pixels comprise 1/4 of all green pixels and the compression noise is reduced in accordance with the foregoing method of filling in missing pixels after decompression by about 12.5% in the decompressed green pixels. As mentioned
15 previously herein, the red and blue pixels each comprise only 1/8 of all pixels in the image and, as will be discussed below, the red and blue pixels are stored and compressed in Γ -space as the Γ -space color difference signals $r-g$ and $b-g$. It can be shown that by refraining
20 from filling in $r-g$ and $b-g$ color difference signals of the missing red and green pixels prior to decompression, the compression noise is reduced in the decompressed color difference signals on the order of 60%.

25 Producing the Γ -Space Color Difference Signals for Compression:

Referring again to Fig. 5, the data processor 28 does not fill in the missing red and blue pixels prior to compression, in accordance with the foregoing discussion.
30 However, the data processor 28 produces the Γ -space color difference signals $r-g$ and $b-g$ prior to compression for those red and blue pixels which are not missing. In order to accomplish this, the missing green pixels are computed at the site of each red or blue pixel. The
35 missing green pixels g_{miss} are filled in (step 48 of Fig.

5) by interpolating the Γ -space green pixel data in each column, in the following column pattern of the 3G CFA 18:

5		g ₁
		g ₂
		g ₃
		g _{miss}
		g ₄
		g ₅
10		g ₆

using the following center-weighted average:

$$g_{\text{miss}} = A \times g_1 + B \times g_2 + C \times g_3 + C \times g_4 + B \times g_5 + A \times g_6$$

15 where:

$$A < B < C.$$

In a preferred embodiment:

$$A = .218$$

$$B = .563$$

20

$$C = .844.$$

In step 50 of Fig. 5, the data processor 28 computes the Γ -space color difference signals r-g and b-g only for those red and blue pixels present in the CFA array, thereby refraining from filling in any missing red or blue pixels prior to compression. Thus, in step 50 the data processor 28 subtracts from each Γ -space red pixel value r the Γ -space value g_{miss} of the corresponding missing green pixel to form the r-g color difference data. Likewise, the processor 28 also subtracts from each Γ -space blue pixel value b the Γ -space value g_{miss} of the corresponding missing green pixel to form the b-g color difference data. The operation of step 50 may be summarized for the ith red or blue pixel as follows:

35 $(r-g)_i = r_i - g_{r_i(\text{miss})}$ and

$$(b-g)_i = b_i - g_{b_i}(\text{miss})$$

where $(r-g)_i$ is the value of the i^{th} r-g color difference
 5 pixel, r_i is the value of the i^{th} Γ -space red pixel and
 $g_{r_i}(\text{miss})$ is the interpolated Γ -space value of the
 missing green pixel at the site of the i^{th} red pixel.
 Also, $(b-g)_i$ is the value of the i^{th} b-g color difference
 pixel, b_i is the value of the i^{th} Γ -space blue pixel and
 10 $g_{b_i}(\text{miss})$ is the interpolated Γ -space value of the
 missing green pixel at the site of the i^{th} blue pixel.

In step 52, the color difference data generated in
 step 50 is stored with the uninterpolated green pixel
 15 data in the memory 29 in three separate memory blocks or
 color data planes (shown in Fig. 1), comprising a memory
 block 54 of 1280 columns and 768 rows of 8-bit bytes
 representing the Γ -space green pixels, a memory block 56
 of 640 columns and 256 rows of 8-bit bytes comprising the
 20 Γ -space r-g color difference data and a memory block 58
 of 640 columns and 256 rows of 8-bit bytes comprising the
 b-g color difference data. The data representing the
 missing green pixels which were filled in to generate the
 color difference data is then discarded.

25

In step 61 of Fig. 5, the data processor 28
 separately compresses the data stored in each of the
 memory blocks 54, 56, 58 of Fig. 1. The digital recorder
 30 records the compressed data on data storage media in
 step 62.

Fig. 6 is a flow diagram depicting successive steps
 of the playback process performed by the data processor
 35 of Fig. 2. The compressed data from the playback
 device 34 corresponds to the uncompressed data planes or

blocks 54, 56, 58 of Fig. 1. This data is decompressed by the data processor 35 in step 64 of Fig. 6 using the inverse of the compression process performed by the data processor 28 of Fig. 1 to produce decompressed data
 5 corresponding to the color data planes or memory blocks 54, 56, 58 of Fig. 1. Then, in step 66 the missing green, red and blue pixels are computed by interpolation of the green (g) data and the r-g and b-g color
 10 difference data to form a block 68 of Γ -space color image data illustrated in Fig. 7 having no missing pixels. The interpolation step 66 of Fig. 6 consists of three steps: the missing green pixels are first filled in by vertical interpolation (step 70 of Fig. 6), then missing color
 15 difference (r-g and b-g) pixels are horizontally interpolated (step 72 of Fig. 6) and then vertically interpolated (step 74 of Fig. 6). Referring to Fig. 7, the block 68 comprises three arrays or color data planes 76, 77, 78 each consisting of 1280 columns and 1024 rows of 8-bit bytes representing the Γ -space red, green and
 20 blue pixels, respectively.

The green pixel interpolation step 70 of Fig. 6 is carried out in the same manner as the green pixel interpolation step 48 of Fig. 5. The horizontal
 25 interpolation step 72 of Fig. 6 fills in the missing red and blue pixels of every fourth pixel row of alternating r-g and b-g pixels in the decompressed image data recovered by the decompression step 64. In every fourth pixel row of the decompressed data, a typical sequence of
 30 Γ -space r-g pixels is:

$$(r-g)_1; (r-g)_{\text{miss}}; (r-g)_2; \dots,$$

while a typical sequence of Γ -space b-g pixels is:

35

$$(b-g)_1; (b-g)_{\text{miss}}; (b-g)_2; \dots,$$

where the subscript "miss" denotes a missing pixel. The corresponding sequence of red and blue pixels in every fourth row of the CFA 18 of Fig. 3 is as follows:

$$r_1, r_{\text{miss}}, r_2, \dots \text{ and} \\ b_1, b_{\text{miss}}, b_2, \dots$$

where r_{miss} and b_{miss} are the missing red and blue pixels in the CFA pattern. The horizontal interpolation of the missing r -space red and blue pixels using the decompressed r -g and b -g r -space data is as follows:

$$r_{\text{miss}} = g_{r_{\text{miss}}} + .5 \times [(r-g)_1 + (r-g)_2] \text{ and} \\ b_{\text{miss}} = g_{b_{\text{miss}}} + .5 \times [(b-g)_1 + (b-g)_2],$$

where $g_{r_{\text{miss}}}$ and $g_{b_{\text{miss}}}$ are the green pixels at the sites of the missing red and blue pixels r_{miss} and b_{miss} , respectively. Of course, no such interpolation is necessary in computing (from the color difference signals) any red and blue pixels r_1 and b_1 which are not missing:

$$r_1 = g_{r_1} + (r-g)_1 \text{ and} \\ b_1 = g_{b_1} + (b-g)_1,$$

where g_{r_1} and g_{b_1} are the interpolated missing green pixels at the site of r_1 and b_1 respectively and $(r-g)_1$ and $(b-g)_1$ are the color difference signals corresponding to r_1 and b_1 .

The vertical interpolation step 74 of Fig. 6 fills in the missing red and blue pixels that occur in every three out of four pixel rows. Following the horizontal

interpolation step of block 72, the Γ -space red and blue pixels have the following patterns for each pixel column:

5	r_1 $r_{(miss)1}$ $r_{(miss)2}$ $r_{(miss)3}$ r_2	b_1 $b_{(miss)1}$ $b_{(miss)2}$ $b_{(miss)3}$ b_2
---	---	---

10 The missing red pixels are vertically interpolated in Γ -space in step 74 by adding corresponding green pixels to color difference signals weighted in accordance with their proximity to the missing red pixels, as follows:

$$r_{(miss)1} = g_{r_{(miss)1}} + A \times (r_1 - g_1) + B \times (r_2 - g_2)$$

$$15 \quad r_{(miss)2} = g_{r_{(miss)2}} + C \times (r_1 - g_1) + D \times (r_2 - g_2)$$

$$r_{(miss)3} = g_{r_{(miss)3}} + E \times (r_1 - g_1) + F \times (r_2 - g_2), \text{ where}$$

20 $g_{r_{(miss)i}}$ is the Γ -space value of the green pixel at the site of the i^{th} missing red pixel $r_{(miss)i}$, and g_1 and g_2 are the interpolated missing green pixel values at the sites of the red pixels r_1 and r_2 . Preferably, in step 74, $A=F=.75$, $C=D=.5$ and $B=E=.25$. The missing blue pixels are vertically interpolated in the same manner.

25 In summary, all of the pre-compression signal processing including the computation of the color difference signals, the compression, the decompression and the post-decompression processing including the interpolation of all missing red, green and blue pixels is carried out in Γ -space, no interim transformations of the data being necessary. The elimination of all interim transformations provides a significant advantage in processing speed, economy of hardware and image quality.

35

Γ -Space Edge Enhancement Process:

5 Upon the completion of the de-compression and
interpolation processes of Fig. 6, the data processor 35
of Fig. 2 enhances or sharpens the Γ -space data of Fig. 7
representing the interpolated red, green and blue pixels
in accordance with a Γ -space edge enhancement process of
10 the invention. The data is prepared in a conventional
manner for video display by the video processor 36 or
prepared in a conventional manner for print-out by the
print processor 37. The edge enhancement process, the
video processing and the print processing are illustrated
15 in Fig. 8. As illustrated in Fig. 8, much of the edge
enhancement process is performed in parallel with the
conventional video processing or in parallel with the
conventional print processing.

20 The Γ -space edge enhancement process 80 of Fig. 8
requires as an input only the luminance-related (green)
 Γ -space data (i.e., block 77 of Fig. 7). This process
begins with two separate bandpass filtering steps carried
out simultaneously, namely a vertical bandpass filtering
25 step 82 and a horizontal bandpass filtering step 84. The
bandpass filtering steps 82, 84 extract high spatial
frequency components from the image which are to be added
back into the original image to boost their amplitude in
the original image, thereby sharpening the image. Using
30 conventional transversal filtering techniques, the
vertical bandpass filter step 82 computes a new value for
each Γ -space green pixel based upon the value of
neighboring pixels within the same column as the current
pixel being processed. The vertical bandpass filter step
35 82 does this for each pixel in a given column and for

each column of Γ -space green pixels in the data block 77 of Fig. 7.

In similar manner and using conventional transversal
5 filtering techniques, the horizontal bandpass filter step
84 computes a new value for each Γ -space green pixel
based upon the value of neighboring pixels within the
same row as the current pixel being processed. The
horizontal bandpass filter step 84 does this for each
10 pixel in a given row and for each row of Γ -space green
pixels in the data block 77 of Fig. 7. For each pixel,
the new Γ -space value computed for it by the vertical
bandpass filter step 82 and the new Γ -space value
computed for it by the horizontal bandpass filter step 84
15 are combined by an adding step 86 to produce a two-
dimensionally bandpass filtered Γ -space pixel value
reflecting the results of both the vertical and
horizontal bandpass filter steps 82, 84.

20 One problem encountered in boosting the high spatial
frequency image components is that more noise will be
boosted along one axis than along the other. This is
particularly true of images produced by a typical CCD
imaging array due to the row-by-row charge transfer
25 process by which an image signal is extracted from the
CCD array. In order to solve this problem, a low pass
filter step 88 is interposed between the output of the
vertical bandpass filter step 82 and the adding step 86.
Preferably, using conventional transversal filtering
30 techniques, the low pass filter step 88 computes a low
pass filtered Γ -space value for each pixel based upon the
two neighboring pixels immediately preceding and
following the current pixel in the data stream using the
coefficient sequence 1-2-1. Thus, in a vertical column

or sequence of three green pixels, g_1 , g_2 , g_3 , the low pass filtered Γ -space value of g_2 is computed as follows:

$$g_2 = 1 \times g_1 + 2 \times g_2 + 1 \times g_3.$$

Other suitable filter coefficient sequences may be
5 selected by the skilled worker.

Another problem with edge enhancing the image is that image features which are already very sharp may be further sharpened to an undesirably exaggerated degree.
10 In order to solve this problem, the Γ -space image data produced by the adding step 86 is "pared" by a paring or filtering step 90. As used herein, paring refers to high amplitude attenuation. The non-linear transfer function of the paring step 90 is illustrated in Fig. 9 for an
15 input amplitude range of 0 to 255 for 8-bit data. The input signal is g_{in} and the output signal is g_{out} . Essentially, for input amplitudes of absolute value zero through 32, a unity gain is provided. The absolute value of g_{out} never exceeds 32 in this embodiment. For input
20 amplitudes above an absolute value 32, the gain rapidly falls below unity until zero gain is reached at maximum input absolute value 255. Thus, for the highest amplitude high spatial frequency components (e.g., very sharp and contrasting edges) virtually no sharpening is
25 performed because they are not boosted, a significant advantage.

As will be described below, the enhanced or sharpened image or array of pixel values thus produced at
30 the output of the paring step 90 is combined with all three blocks or planes of color data (red and blue as well as green).

In the video processing step 94 performed by the
35 video processor 36 of Fig. 2 and in the print processing

step 96 performed by the print processor 37 of Fig. 2, the Γ -space r, g and b data is back-transformed to linear space (by computing the Γ power of the amplitude of each Γ -space pixel). Then, the video processing step 94 and the pre-print processing step 96 employ conventional techniques to prepare the resulting R,G,B signal for output to a video display or printer, respectively. In particular, the color signals must be adjusted in accordance with the particular color response of the video monitor or the printer/print media. In the case of the printer and media, a further adjustment must be made to perform density correction using conventional techniques. The video processing step 94 and the pre-print processing step 96 then back-transform their color adjusted data to Γ -space. The Γ -space green, red and blue pixel values output by the video processing step 94 are each combined in an adding and clipping step 98 with the corresponding sharpened pixel values output by the edge enhancement process 80 so that the video-processed green, red and blue video color images are each individually sharpened. The resulting video processed data is then sent to a color video display device. The Γ -space green, red and blue pixel values output by the print processing step 96 are each combined in an adding and clipping step 100 with corresponding sharpened pixel values output by the edge enhancement process 80, so that the print processed green, red and blue images are each individually sharpened. The resulting print processed image data is transformed in step 102 to another space compatible with a printer (such as log) and sent to a printer.

Cascaded Modulation Transfer Functions for Controlling Bit Resolution of Each Component of the Compressed Image:

In order to solve the problem of the edge enhancement process making the compression-induced noise more visible in the image to the human eye, the edge enhancement process modulation transfer function is taken
5 into account along with the human visual contrast sensitivity function in computing normalization factors which determine the bit resolution (i.e., number of representative bits) of respective spatial frequency components of the compressed data produced by step 61 of
10 the process of Fig. 5. In order to compensate for the effect of the video display on the visibility to the human eye of compression-induced noise in the image, the display modulation transfer function is also taken into account in computing the normalization factors. In
15 general, the modulation transfer functions of any steps in the image recording/playback process tending to affect visibility to the human eye of compression noise may be cascaded together with the human visual contrast sensitivity function in accordance with the invention to
20 generate an array of normalization factors for the compression process. This will now be described with reference to the compressing step 61 of Fig. 5 performed by the data compressor 28 of Fig. 1 and further with reference to the decompressing step 64 of Fig. 6
25 performed by the data decompressor 35 of Fig. 2.

Fig. 10a illustrates in detail the compression process performed in step 61 of Fig. 5 by the data processor 28. This process begins by taking an
30 individual one of the g, r-g or b-g Γ -space memory blocks or color data planes 54, 56, 58 (of Fig. 1) and dividing it into many small transform blocks of pixels (step 116 of Fig. 10a). This step is depicted in further detail in Fig. 11. In the preferred embodiment, each small
35 transform block has 16 rows and 16 columns of pixels

$I(x,y)$. Referring again to Fig. 10a, each 16-by-16 transform block thus generated is transformed by a discrete cosine transform (DCT) step 118, to generate a 16-by-16 block of DCT coefficients $T(i,j)$. The DCT coefficient block is sequentialized in step 120 to a stream of DCT coefficients $T(k)$. The number of encoded bits which will represent each coefficient in the compressed data is then determined by a normalization step 124 and a quantization step 126. The normalization step 124 consists of dividing each DCT coefficient $T(k)$ in the sequentialized 16-by-16 DCT block by a normalization factor generated for that particular coefficient by a normalization array generating step 125. The normalization step 124 produces a normalized coefficient $TN(k)$. The number of encoded bits which will represent the compressed version of the particular coefficient is inversely proportional, approximately, to the amplitude of the normalization factor. The quantization step 126 quantizes each normalized coefficient $TN(k)$ to produce a quantized coefficient $\hat{T}N(k)$. The normalized and quantized DCT coefficients $\hat{T}N(k)$ are then minimum-redundancy (Huffman) encoded and run-length encoded in step 128 to produce the encoded bits comprising compressed DCT coefficients $CV(k)$, which completes the compression process. As described in the above-referenced U.S. Patent No. 4,780,761 to Scott J. Daly et al., the normalization array generating step 125 generates a 16-by-16 array of normalization factors $N(k)$ associated with the 16-by-16 block of DCT coefficients in such a manner as to compensate for the human visual contrast sensitivity function. In accordance with the present invention, the normalization array generating step 125 further compensates for the modulation transfer functions of the edge enhancement process (or any other

image signal process as desired) and of the image display, as will be described below.

Fig. 10b illustrates in detail the decompression process performed in step 64 of Fig. 6 by the data processor 35. In the first step of this process (step 130 of Fig. 10b), the compressed DCT coefficients $CV(k)$ are decoded in accordance with the minimum redundancy (Huffman) codes and run length codes to produce the normalized coefficients $\hat{T}N(k)$. The normalized coefficients are denormalized in step 132 to produce the DCT coefficients $T(k)$. The denormalization step 132 is accomplished by multiplying each DCT coefficient by the same normalization factor by which it was previously divided in the compression process. For this purpose, the normalization array generating step 125 of the compression process of Fig. 10a is repeated as the normalization array generating step 125' in the decompression process of Fig. 10b. In one embodiment, the normalization generating step 125' of Fig. 10b furnishes the reciprocals $N^{-1}(k)$ of the normalization factors. The DCT coefficients $T(k)$ are then reformatted into a 16-by-16 block $T(i,j)$ in step 136 and inverse DCT transformed in step 138 to a 16-by-16 image block $I(x,y)$. The image blocks thus generated are assembled together in step 140 to form the reproduced g, r-g or b-g image.

Fig. 12 illustrates how the normalization array generating step 125 cascades the different modulation transfer functions and the human contrast sensitivity function to form the normalization array $N(k)$. In essence, the predominant spatial frequency of each DCT coefficient in the 16-by-16 block is estimated in different units suitable for correlation with modulation transfer functions of different processes (namely, the

edge enhancement process, the image display process and the human visual perception process). The first step (step 142 of Fig. 12) is to compute the frequency in cycles per block of each DCT coefficient based upon the specific parameters employed in the discrete cosine transform used to generate the DCT coefficients. Next, in step 144 of Fig. 12 the number of cycles per pixel is computed from the number of cycles per block for each DCT coefficient and from the number of pixel rows (B_x) and columns (B_y) in each block, which in the preferred embodiment is 16 rows and 16 columns. The two-dimensional modulation transfer function of the edge enhancement process of Fig. 8 is readily generated by the skilled worker using ordinary techniques and is best expressed in the dimension of step 144, namely cycles per pixel. The results of step 144 are exploited in step 146 by associating an amplitude from the edge enhancement modulation transfer function with each DCT coefficient based upon its predominant spatial frequency in cycles per pixel. This produces a 16-by-16 edge enhancement modulation transfer function array. In Fig. 13a, the shape of the three dimensional surface corresponds to the two dimensional modulation transfer function of the edge enhancement process 80 Fig. 8. The intersection points in the grid superimposed on the three dimensional surface of Fig. 13a are the amplitudes associated with the individual DCT coefficients in step 146.

Next, in step 148 of Fig. 12 the number of cycles per unit distance (e.g., millimeters) is computed for each DCT coefficient from the number of cycles per pixel and from the pixel-to-pixel spacing P_x , P_y of the CFA 18 of Fig. 3 for example. The two-dimensional modulation transfer function of the image display is readily generated by the skilled worker using ordinary techniques

from the known characteristics of the image display (video monitor or print media) to be employed and is best expressed in units of cycles per unit distance (millimeters). This follows from the fact that the perception of texture and edges in printed media, for example, is affected by the pixel spacing on the media. Then, step 150 exploits the results of step 148 by associating an amplitude from the display modulation transfer function with each DCT coefficient based upon its spatial frequency in cycles per millimeter. This produces a 16-by-16 image display modulation transfer function array. In Fig. 13b, the shape of the three dimensional surface corresponds to the two dimensional modulation transfer function of the image display. The intersection points in the grid superimposed on the three dimensional surface of Fig. 13b are the amplitudes associated with the individual DCT coefficients in step 150.

Next, in step 152 the number of cycles per degree of the visual angle (or subtense) is computed for each DCT coefficient from the number of cycles per millimeter and from the assumed distance V between the viewer and the display. The two-dimensional human visual contrast sensitivity function (CSF) is obtained in accordance with the teachings of the above-referenced U.S. Patent No. 4,780,761 to Scott J. Daly et al. and is best expressed in units of cycles per degree of visual degree. One aspect of the CSF reflects the eye's perception of high spatial frequencies being affected by the distance to the image. There are other aspects also which need not be mentioned herein. Step 154 of Fig. 12 exploits the results of step 152 by associating an amplitude from the human visual contrast sensitivity function with each DCT coefficient based upon its spatial frequency in cycles

per degree. The result is a 16-by-16 human contrast sensitivity function array. In Fig. 13c, the shape of the three dimensional surface corresponds to the two dimensional contrast sensitivity function of the image display. The intersection points in the grid superimposed on the three dimensional surface of Fig. 13c are the amplitudes associated with the individual DCT coefficients in step 154.

10 The display and edge enhancement modulation transfer function arrays are multiplied together in a multiplication step 156 coefficient-by-coefficient and the resulting 16-by-16 product array is multiplied by the contrast sensitivity array in a multiplication step 158 to produce a cascaded array illustrated in Fig. 13d. Each element of the resulting cascaded array is converted to its reciprocal in step 160 and multiplied by a bit rate factor to produce the normalization array illustrated in Fig. 14a. The normalization array may then be loaded into a look-up table, for example. The result (Fig. 14a) contrasts dramatically with the normalization array of Fig. 14b (disclosed in the above-referenced U.S. Patent to Scott Daly et al.) which takes into account the human visual contrast sensitivity function only.

In order to compensate for the lower spatial frequency response of the eye to color difference signals, different normalization arrays are produced by the normalization array generating step 125 for use in compressing the r-g and b-g color difference signals. For this purpose, the normalization array generating step 125 of Fig. 10a is depicted as three generating in steps 125a, 125b, 125c, labelled "green", "red-green" and "blue-green", respectively. The appropriate one of the

normalization array generating steps 125a, 125b, 125c is selected depending upon whether the green signal or one of the color difference signals is to be compressed. Thus, a different normalization array is used with each
 5 of the g, r-g and b-g data blocks. Likewise, the normalization array generating step 125' of Fig. 10b is divided into separate normalization array generating steps 125'a, 125'b, 125'c.

10 The normalization arrays for the color difference signals compensate for the lower frequency human visual response to the color difference signals by altering the human visual contrast sensitivity function model described in the above-referenced U.S. Patent No.
 15 4,780,764 to Scott J. Daly et al. Specifically, the frequency variable r in the human visual contrast sensitivity function model equation

$$H(r) = HA \times (HB + HC \times r) \exp(-HC \times r)^{HD}$$

is multiplied by a factor greater than one. For the r-g
 20 color difference data block, this factor preferably equals 2 and the model equation thus becomes:

$$H(r) = HA \times (HB + HC \times 2r) \exp(-HC \times 2r)^{HD}$$

for the r-g color difference signal. For the b-g color difference data block, the factor preferably equals 4.
 25 This reduces the effective bandwidth of the resulting contrast sensitivity function, thus accommodating the lower frequency response of the eye to the color differences r-g and b-g compared with the eye's response to green. The remaining steps in generating the 2-
 30 dimensional human visual contrast sensitivity function and producing therefrom the 16-by-16 contrast sensitivity function array are described in the above-referenced U.S. patent to Daly et al. and need not be described herein.

Because the CFA has different pixel-to-pixel spacings or patterns for different colors (illustrated in Fig. 3) and because the factors for the frequency variable r are different for the r-g and b-g blocks, the steps of Fig. 12 produce a different normalization array for each of the color difference signals. For example, the r-g normalization array is illustrated in Fig. 15a and the b-g normalization array is illustrated in Fig. 15b.

10

While the invention has been described with reference to a preferred embodiment using a 3G CFA in which the luminance-related color is green and the chrominance-related signals are r-g and b-g, other CFA's having different color schemes, different spatial patterns and a different luminance-related color as well as a different set of chrominance-related or color difference signals may be employed in carrying out the invention.

20

While the invention has been described in detail by specific reference to preferred embodiments thereof, modifications and variations thereof may be made without departing from the true spirit and scope of the invention.

25

What is claimed is:

1. Apparatus for transmitting and receiving a color image signal representing the amplitudes of a single image plane of pixels, each one of said pixels
5 representing a respective one of three different colors whereby pixels of pairs of said colors are missing at sites of respective individual pixels, one of said three colors being more closely related to luminance than the remaining colors, said apparatus comprising:
 - 10 A) transmitting means comprising:
 - 1) means for transforming the amplitude of each of said pixels to a Γ -space amplitude by changing its original value A to $A^{1/\Gamma}$, where Γ is a real number, whereby the Γ -space amplitudes of the pixels of said one
15 color comprise a first input color data plane;
 - 2) first means for inferring by interpolation the Γ -space amplitudes of the missing pixels of said one color;
 - 3) means for forming second and third
20 input color data planes of respective color difference signals by subtracting the Γ -space amplitudes of said missing pixels of said one color from the Γ -space amplitudes of corresponding pixels of each of said remaining colors, respectively;
 - 25 4) means for compressing each of said input color data planes to form corresponding first, second and third compressed color data planes;
 - B) receiving means comprising:
 - 1) means for decompressing said first,
30 second and third compressed color data planes to form, respectively, first, second and third decompressed color data planes;
 - 2) means for converting said first, second and third decompressed color data planes to first, second
35 and third output color data planes, respectively, of

Γ -space amplitudes of pixels of respective ones of said three colors;

3) means for edge enhancing said first, second and third output color data planes; and

5 4) means for back-transforming each of the Γ -space amplitudes $A^{1/\Gamma}$ of the pixels of said output color data planes to amplitudes A .

2. The apparatus of Claim 1 wherein said image
10 plane corresponds to a color filter array, said one color related to luminance is green and said remaining colors are red and blue and wherein Γ is about 2.4.

3. The apparatus of Claim 1 wherein said
15 transmitting means further comprise means for recording said compressed color data planes and wherein said receiving means further comprise means for playing back the compressed color data planes recorded by said means for recording.

20 4. The apparatus of Claim 1 wherein said means for converting comprise means for determining from said decompressed color data planes Γ -space amplitudes of missing pixels of said three colors.

25 5. The apparatus of Claim 4 wherein said means for determining comprises:

first means for computing from said first decompressed color data plane interpolated Γ -space
30 amplitudes of missing pixels of said one color to produce said first output color data plane;

first means for adding said interpolated Γ -space amplitudes of said one color to corresponding Γ -space color difference signal amplitudes of said second
35 and third decompressed color planes.

6. The apparatus of Claim 5 wherein said means for determining further comprises:

5 second means for computing from said second and third decompressed color data planes interpolated Γ -space amplitudes of color difference signals corresponding to missing pixels of said remaining colors; and

10 second means for adding Γ -space amplitudes of pixels of said first decompressed color data plane to corresponding ones of said interpolated color difference signal Γ -space amplitudes computed by said second means for computing, to produce interpolated Γ -space amplitudes of the missing pixels of said remaining colors.

15 7. The apparatus of Claim 6 wherein said image plane comprises pixel columns and pixel rows in a planar array of said pixels and said color related to luminance is green and has missing pixels in every n^{th} pixel row of said image plane and said remaining colors are red and
20 blue and have alternate pixels in every n^{th} pixel row of said image plane, whereby said color difference signals correspond to red minus green and blue minus green, and wherein:

25 said first means for computing comprises means for vertically interpolating Γ -space amplitudes of missing green pixels within each pixel column of said first decompressed color data plane;

said second means for computing comprises:

30 (1) means for horizontally interpolating color difference signal Γ -space amplitudes corresponding to missing red and blue pixels in respective rows of said second and third compressed color data planes, and

(2) means for vertically interpolating color difference signal Γ -space amplitudes corresponding

to missing red and blue pixels in each pixel column of said second and third compressed color data planes.

8. The apparatus of Claim 4 wherein said first
5 output color data plane corresponds to said one color related to luminance and wherein said means for edge enhancing comprises:

means for bandpass filtering each pixel column
of Γ -space pixel amplitudes of said first output color
10 data plane to produce a corresponding column of bandpass filtered Γ -space pixel amplitudes;

means for bandpass filtering each pixel row of
 Γ -space pixel amplitudes of said first output color data
plane to produce a corresponding row of bandpass filtered
15 Γ -space pixel amplitudes;

means for combining said bandpass filtered
pixel rows and columns to produce two-dimensionally
bandpass filtered Γ -space pixel amplitudes;

means for paring said two-dimensionally
20 bandpass filtered Γ -space amplitudes whereby to boost high spatial frequency components having lower amplitudes and suppress high spatial frequency components having higher amplitudes; and

means for adding the Γ -space pixel amplitudes
25 produced by said means for paring to amplitudes of corresponding pixels in each of said first, second and third output color data planes.

9. The apparatus of Claim 8 wherein said columns
30 of bandpass filtered amplitudes have greater high spatial frequency noise than said rows of bandpass filtered amplitudes, said apparatus further comprising:

means for low pass filtering said columns of
bandpass filtered amplitudes.

10. The apparatus of Claim 8 further comprising means for output color adjusting said amplitudes of the pixels of said output color data planes.

5 11. The apparatus of Claim 1 wherein:

A) said means for compressing comprises:

1) means for dividing each of said input color data planes into transform blocks,

2) means for transforming the Γ -space
10 amplitudes of each of said transform blocks into spatial frequency coefficients,

3) means for determining the number of encoded bits to represent each of said spatial frequency coefficients in compressed versions of said coefficients
15 in accordance with a cascaded modulation transfer function corresponding to modulation transfer functions of selected elements of said apparatus,

4) encoding means for producing said encoded bits; and

20 B) wherein said means for decompressing comprises:

1) means for converting said encoded bits to decompressed spatial frequency coefficients,

2) means for back-transforming said
25 decompressed spatial frequency coefficients of each transform block to pixel amplitudes.

12. The apparatus of Claim 11 wherein said means for determining the number of encoded bits to represent
30 each spatial frequency coefficient comprises:

means for producing a normalization array corresponding to said cascaded modulation transfer function;

35 means for dividing each spatial frequency coefficient by a corresponding element of said

normalization array whereby to produce first normalized coefficients; and

means for quantizing said first normalized coefficients.

5

13. The apparatus of Claim 12 further comprising means for displaying an image of pixel amplitudes produced by the back-transforming means, wherein said cascaded modulation transfer function corresponds to modulation transfer functions of said means for edge enhancing and of said means for displaying.

14. The apparatus of Claim 13 wherein said cascaded modulation transfer function further corresponds to a human visual contrast sensitivity function.

15. The apparatus of Claim 14 wherein said means for producing said normalization array corresponding to said cascaded modulation transfer function comprises:

20 means for determining from the number of pixel rows and pixel columns in each of said transform blocks the number of cycles per pixel of each of said spatial frequency coefficients and means for associating each coefficient with a value of a modulation transfer function of said means for edge enhancing at a corresponding spatial frequency in cycles per pixel whereby to form an edge enhancement modulation transfer function array;

25 means for determining from pixel spacing corresponding to said means for displaying the number of cycles per unit distance of each of said spatial frequency coefficients and means for associating each coefficient with a value of a modulation transfer function of said means for displaying at a corresponding

35

spatial frequency in cycles per unit distance whereby to form a display modulation transfer function array;

means for determining from a viewing distance corresponding to said means for displaying the number of
5 cycles per degree of visual scan of each of said spatial frequency coefficients and means for associating each coefficient with a value of a human visual contrast sensitivity function at a corresponding spatial frequency in cycles per degree whereby to form a human visual
10 contrast sensitivity function array;

means for cascading said arrays together whereby to form a cascaded array of plural elements comprising said cascaded modulation transfer function;
and

15 means for inversing each element of the cascaded array.

16. The apparatus of Claim 12 wherein said means for converting said encoded bits to decompressed spatial
20 frequency coefficients comprises:

means for decoding said encoded bits whereby to produce second normalized spatial frequency coefficients;
and

25 means for multiplying said second normalized spatial frequency coefficients by corresponding elements of said normalization array whereby to produce said decompressed spatial frequency coefficients.

17. The apparatus of Claim 15 further comprising
30 means for reducing the bandwidth of said human visual contrast sensitivity function by a predetermined factor whenever said means for compressing compresses said second or third input color data planes.

18. The apparatus of Claim 17 wherein the spatial patterns of the pixels of said three colors in said image plane are different, whereby said means for determining the number of cycles per unit distance of said spatial frequency coefficients produce different normalization arrays depending upon which one of said first, second or third input color data planes is being compressed.

19. The apparatus of Claim 17 wherein said second and third input color data planes comprise red minus green and blue minus green color difference signals and wherein said predetermined factor is 2 for said second input color data plane and 4 for said third input color data plane.

15

20. The apparatus of Claim 11 wherein said means for transforming to spatial frequency coefficients performs a discrete cosine transform process, and wherein said means for producing said encoded bits comprises means for encoding each of said spatial frequency coefficients in accordance with a minimum redundancy code.

21. Apparatus for transmitting and receiving image data comprising arrays of pixels, comprising:

A) transmitting means for compressing said data, comprising:

1) means for transforming the pixels of each of said arrays into spatial frequency coefficients;

2) means for representing each of said spatial frequency coefficients by a number of bits in compressed versions of said coefficients in accordance with a cascaded modulation transfer function corresponding to means by which said data is to be displayed; and

B) receiving means for decompressing data compressed by said transmitting means, comprising:

1) means for producing decompressed coefficients from said compressed versions of said
5 coefficients,

2) means for back-transforming said decompressed coefficients to pixels.

22. The apparatus of Claim 21 wherein said means
10 for representing comprises:

means for producing a normalization array having plural normalization factors corresponding to said cascaded modulation transfer function;

normalizing means for dividing each spatial
15 frequency coefficient by a corresponding factor in said normalization array to produce a normalized coefficient; and

means for quantizing said normalized coefficient.

20

23. The apparatus of Claim 22 further comprising means for edge enhancing an image comprising the pixels produced by said means for back-transforming and means for displaying an image comprising the pixels produced by
25 said means for edge enhancing, wherein said cascaded modulation transfer function corresponds to modulation transfer functions of said means for edge enhancing and of said means for displaying.

30 24. The apparatus of Claim 23 wherein said cascaded modulation transfer function further corresponds to a contrast sensitivity function of the human visual system.

35 25. The apparatus of Claim 24 wherein said means for transforming to spatial frequency coefficients

comprises means for dividing the arrays of pixels into plural transform blocks of pixels and means for spatial frequency transforming each of said blocks, and wherein said means for producing said normalization array
5 corresponding to said cascaded modulation transfer function comprises:

means for determining from the number of pixel rows and columns in each of said transform blocks the number of cycles per pixel of each of said spatial
10 frequency coefficients and means for associating each coefficient with an amplitude of a modulation transfer function of said means for edge enhancing at a corresponding spatial frequency in cycles per pixel whereby to form an edge enhancement modulation transfer
15 function array;

means for determining from pixel spacing corresponding to said means for displaying the number of cycles per unit distance of each of said spatial frequency coefficients and means for associating each
20 coefficient with an amplitude of a modulation transfer function of said means for displaying at a corresponding spatial frequency in cycles per unit distance whereby to form a display modulation transfer function array;

means for determining from a viewing distance corresponding to said means for displaying the number of cycles per degree of visual scan of each of said spatial frequency coefficients and means for associating each
25 coefficient with an amplitude of the human visual contrast sensitivity function at a corresponding spatial frequency in cycles per degree whereby to form a visual
30 contrast sensitivity function array;

means for cascading said arrays together to form a cascaded array of plural elements comprising said cascaded modulation transfer function; and

means for inversing each element of the cascaded array.

26. The apparatus of Claim 22 wherein said means
5 for decompressing comprises denormalizing means for multiplying each decompressed coefficient by the corresponding factor in said normalization array.

27. The apparatus of Claim 25 wherein said arrays
10 represent, respectively, a luminance related component and a pair of color difference components of a color image, said apparatus further comprising means for reducing the bandwidth of said human visual contrast sensitivity function by a predetermined factor whenever
15 said means for compressing compresses coefficients of a color difference component.

28. The apparatus of Claim 27 wherein the spatial patterns of the pixels of said components are different,
20 whereby said means for determining the number of cycles per unit distance of said spatial frequency coefficients produces different normalization arrays depending upon which one of the arrays of pixels is being compressed.

29. The apparatus of Claim 27 wherein said color difference components comprise red minus green and blue minus green color difference components and wherein said predetermined factor is 2 for the red minus green component and 4 for the blue minus green component.
25

30. The apparatus of Claim 21 wherein said means for transforming to spatial frequency coefficients comprises means for performing a discrete cosine transform process, and wherein said means for compressing
30 further comprises means for encoding each of said spatial

frequency coefficients in accordance with a minimum redundancy code.

31. Apparatus for edge enhancing a color image
5 comprising three arrays of rows and columns of pixel amplitudes corresponding to three colors, one of said colors being more related to luminance than the others, comprising:

means for bandpass filtering each column of
10 pixel amplitudes of said color related to luminance to produce a corresponding column of bandpass filtered pixel amplitudes;

means for bandpass filtering each row of pixel amplitudes of said color related to luminance to produce
15 a corresponding column of bandpass filtered pixel amplitudes;

means for combining said bandpass filtered pixel rows and columns to produce two-dimensionally bandpass filtered pixel amplitudes;

20 means for paring said two-dimensionally bandpass filtered amplitudes so as to boost high spatial frequency components having lower amplitudes and so as to attenuate high spatial frequency components having higher amplitudes; and...

25 means for adding the two-dimensionally bandpass filtered pixel amplitudes to corresponding amplitudes of the pixels of each of said three colors.

32. The apparatus of Claim 31 wherein each column
30 of bandpass filtered amplitudes has more noise than each row, said apparatus further comprising:

means for low pass filtering each column of bandpass filtered amplitudes.

33. The apparatus of Claim 31 further comprising means for output color adjusting said corresponding amplitudes of the pixels of said three colors.

5 34. Apparatus for transmitting a color image signal representing the amplitudes of a single image plane of pixels, each one of said pixels representing a respective one of three different colors whereby pixels of pairs of said colors are missing at sites of respective individual
10 pixels, one of said three colors being more closely related to luminance than the remaining colors, said apparatus comprising:

means for transforming the amplitude of each of said pixels to a Γ -space amplitude by changing its
15 original value A to $A^{1/\Gamma}$, where Γ is a real number, whereby the Γ -space amplitudes of the pixels of said one color comprise a first input color data plane;

first means for inferring by interpolation the Γ -space amplitudes of the missing pixels of said one
20 color;

means for forming second and third input color data planes of respective color difference signals by subtracting the Γ -space amplitudes of said missing pixels of said one color from the Γ -space amplitudes of
25 corresponding pixels of each of said remaining colors, respectively; and

means for compressing each of said input color data planes to form corresponding first, second and third compressed color data planes.

30

35. The apparatus of Claim 34 wherein said image plane corresponds to a color filter array, said one color related to luminance is green and said remaining colors are red and blue and wherein Γ is about 2.4.

36. The apparatus of Claim 34 further comprising means for recording said compressed color data planes.

37. The apparatus of Claim 34 wherein said means
5 for compressing comprises:

1) means for dividing each of said input color data planes into transform blocks,

2) means for transforming the Γ -space amplitudes of each of said transform blocks into spatial
10 frequency coefficients,

3) means for determining the number of encoded bits to represent each of said spatial frequency coefficients in compressed versions of said coefficients in accordance with a cascaded modulation transfer
15 function corresponding to modulation transfer functions of image output elements, and

4) encoding means for producing said encoded bits.

20 38. The apparatus of Claim 37 wherein said means for determining the number of encoded bits to represent each spatial frequency coefficient comprises:

means for producing a normalization array corresponding to said cascaded modulation transfer
25 function;

normalization means for dividing each spatial frequency coefficient by a corresponding element of said normalization array whereby to produce first normalized coefficients; and

30 means for quantizing said first normalized coefficients.

39. The apparatus of Claim 38 wherein said cascaded modulation transfer function corresponds to modulation

transfer functions of an edge enhancing apparatus and of an image displaying apparatus.

40. The apparatus of Claim 39 wherein said cascaded
5 modulation transfer function further corresponds to a human visual contrast sensitivity function.

41. The apparatus of Claim 40 wherein said means
for producing said normalization array corresponding to
10 said cascaded modulation transfer function comprises:

means for determining from the number of pixel
rows and pixel columns in each of said transform blocks
the number of cycles per pixel of each of said spatial
frequency coefficients and means for associating each
15 coefficient with a value of the modulation transfer
function of said edge enhancing apparatus at a
corresponding spatial frequency in cycles per pixel
whereby to form an edge enhancement modulation transfer
function array;

20 means for determining from pixel spacing
corresponding to the displaying means the number of
cycles per unit distance of each of said spatial
frequency coefficients and means for associating each
coefficient with a value of the modulation transfer
25 function of said image displaying apparatus at a
corresponding spatial frequency in cycles per unit
distance whereby to form a display modulation transfer
function array;

means for determining from a viewing distance
30 corresponding to said image displaying apparatus the
number of cycles per degree of visual scan of each of
said spatial frequency coefficients and means for
associating each coefficient with a value of the human
visual contrast sensitivity function at a corresponding

spatial frequency in cycles per degree whereby to form a human visual contrast sensitivity function array; and

means for cascading said arrays together whereby to form a cascaded array of plural elements
5 comprising said cascaded modulation transfer function; and

means for inversing each element of the cascaded array to form said normalization array.

10 42. The apparatus of Claim 41 further comprising means for reducing the bandwidth of said human visual contrast sensitivity function by a predetermined factor whenever said means for compressing compresses said
15 second or third input color data planes.

43. The apparatus of Claim 42 wherein the spatial patterns of the pixels of said three colors in said image plane are different, whereby said means for determining the number of cycles per unit distance of said spatial
20 frequency coefficients produce different normalization arrays depending upon which one of said first, second or third input color data planes is being compressed.

44. The apparatus of Claim 42 wherein said second
25 and third input color data planes comprise red minus green and blue minus green color difference signals and wherein said predetermined factor is 2 for said second input color data plane and 4 for said third input color data plane.

30 45. The apparatus of Claim 37 wherein said means for transforming to spatial frequency coefficients comprises means for performing a discrete cosine transform, and wherein said means for producing said
35 encoded bits comprises means for encoding each of said

spatial frequency coefficients in accordance with a minimum redundancy code.

46. Apparatus for transmitting image data
5 comprising arrays of pixels, comprising:
- 1) means for transforming the pixels of each of said arrays into spatial frequency coefficients; and
 - 2) means for representing each of said spatial frequency coefficients by a number of bits in compressed
10 versions of said coefficients in accordance with a cascaded modulation transfer function representing means by which said data is to be displayed.

47. The apparatus of Claim 46 wherein said means
15 for representing comprises:
- means for producing a normalization array having plural normalization factors corresponding to said cascaded modulation transfer function;
- normalizing means for dividing each spatial
20 frequency coefficient by a corresponding factor in said normalization array to produce a normalized coefficient; and
- means for quantizing said normalized coefficient.

- 25
48. The apparatus of Claim 47 wherein said cascaded modulation transfer function corresponds to an edge enhancement modulation transfer function of an edge enhancing means and to a display modulation transfer
30 function of an image displaying means.

49. The apparatus of Claim 48 wherein said cascaded modulation transfer function further corresponds to a contrast sensitivity function of the human visual system.

50. The apparatus of Claim 49 wherein said means for transforming to spatial frequency coefficients comprises means for dividing the arrays of pixels into plural transform blocks of pixels and means for spatial
5 frequency transforming each of said blocks, and wherein said means for representing comprises means for computing said cascaded modulation transfer function comprising:

means for determining from the number of pixel rows and columns in each of said transform blocks the
10 number of cycles per pixel of each of said spatial frequency coefficients and means for associating each coefficient with an amplitude of the edge enhancement modulation transfer function at a corresponding spatial
frequency in cycles per pixel whereby to form an edge
15 enhancement modulation transfer function array;

means for determining from pixel spacing corresponding to said display modulation transfer function the number of cycles per unit distance of each
of said spatial frequency coefficients and means for
20 associating each coefficient with an amplitude of the display modulation transfer function at a corresponding spatial frequency in cycles per unit distance whereby to form a display modulation transfer function array;

means for determining from a viewing distance
25 corresponding to said display modulation transfer function the number of cycles per degree of visual scan of each of said spatial frequency coefficients and means for associating each coefficient with an amplitude of the human visual contrast sensitivity function at a
30 corresponding spatial frequency in cycles per degree whereby to form a visual contrast sensitivity function array;

means for cascading said arrays together to form a cascaded array of plural elements comprising said
35 cascaded modulation transfer function; and

means for inversing each element of the cascaded array.

51. The apparatus of Claim 50 wherein said arrays
5 of pixels represent, respectively, a luminance related component and a pair of color difference components of a color image, said apparatus further comprising means for reducing the bandwidth of said human visual contrast sensitivity function by a predetermined factor whenever
10 said means for compressing compresses coefficients of a color difference component.

52. The apparatus of Claim 51 wherein the spatial patterns of the pixels of said components are different,
15 whereby said means for determining the number of cycles per unit distance of said spatial frequency coefficients produces different normalization arrays depending upon which one of the arrays of pixels is being compressed.

20 53. The apparatus of Claim 51 wherein said color difference components comprise red minus green and blue minus green color difference components and wherein said predetermined factor is 2 for the red minus green component and 4 for the blue minus green component.

25 54. The apparatus of Claim 46 wherein said means for transforming to spatial frequency coefficients comprises means for performing a discrete cosine transform process, said means for representing further
30 comprising means for encoding each of said spatial frequency coefficients in accordance with a minimum redundancy code.

55. Apparatus for receiving a color image signal comprising compressed data corresponding to Γ -space amplitudes $A^{1/\Gamma}$ of a single image plane of pixels, each one of said pixels representing a respective one of three
5 different colors whereby pixels of pairs of said colors are missing at sites of respective individual pixels, one of said three colors being more closely related to luminance than the remaining colors, said compressed data comprising a first compressed color data plane comprising
10 the Γ -space amplitudes of the pixels of said one color and second and third compressed color data planes comprising respective color difference signals formed by subtracting interpolated Γ -space amplitudes of missing
15 pixels of said one color from the Γ -space amplitudes of corresponding pixels of each of said remaining colors, respectively, said apparatus comprising:

means for decompressing said compressed data to form first, second and third decompressed color data planes of Γ -space amplitudes corresponding to said first,
20 second and third compressed color data planes, respectively;

means for converting said first, second and third decompressed color data planes to first, second and third output color data planes, respectively, of Γ -space
25 amplitudes of pixels of respective ones of said three colors;

means for edge enhancing said first, second and third output color data planes; and

means for back-transforming each of the Γ -space
30 amplitudes $A^{1/\Gamma}$ of the pixels of said output color data planes to amplitudes A .

56. The apparatus of Claim 55 wherein said image plane corresponds to a color filter array, said one color

related to luminance is green and said remaining colors are red and blue and wherein Γ is about 2.4.

57. The apparatus of Claim 55 wherein said color
5 image signal has been previously recorded, said apparatus further comprising means for playing back said color image signal.

58. The apparatus of Claim 55 wherein said means
10 for converting comprises means for determining from said decompressed color data planes Γ -space amplitudes of missing pixels of said three colors.

59. The apparatus of Claim 58 wherein said means
15 for determining comprises:

first means for computing from said first decompressed color data plane interpolated Γ -space amplitudes of missing pixels of said one color to produce said first output color data plane;

20 first means for adding said interpolated Γ -space amplitudes of said one color to corresponding Γ -space color difference signal amplitudes of said second and third decompressed color planes.

25 60. The apparatus of Claim 59 wherein said means for determining further comprises:

second means for computing from said second and third decompressed color data planes interpolated Γ -space amplitudes of color difference signals corresponding to
30 missing pixels of said remaining colors; and

second means for adding Γ -space amplitudes of pixels of said first decompressed color data plane to corresponding ones of said interpolated color difference signal Γ -space amplitudes computed by said second means
35 for computing, whereby to produce interpolated Γ -space

amplitudes of the missing pixels of said remaining colors.

61. The apparatus of Claim 60 wherein said image
5 plane comprises pixel columns and pixel rows in a planar array of said pixels and said color related to luminance is green and has missing pixels in every n^{th} pixel row of said image plane and said remaining colors are red and
10 blue and have alternate pixels in every n^{th} pixel row of said image plane, whereby said color difference signals correspond to red minus green and blue minus green, and wherein:

said first means for computing comprises means
for vertically interpolating Γ -space amplitudes of
15 missing green pixels within each pixel column of said first decompressed color data plane;

said second means for computing comprises:

means for horizontally interpolating color
20 difference signal Γ -space amplitudes corresponding to missing red and blue pixels in respective pixel rows of said second and third compressed color data planes, and
means for vertically interpolating color
difference signal Γ -space amplitudes corresponding to
25 missing red and blue pixels in each pixel column of said second and third compressed color data planes.

62. The apparatus of Claim 58 wherein said first
output color data plane corresponds to said one color
related to luminance and wherein said means for edge
30 enhancing comprises:

means for bandpass filtering each pixel column
of Γ -space pixel amplitudes of said first output color
data plane to produce a corresponding column of bandpass
filtered Γ -space pixel amplitudes;

means for bandpass filtering each pixel row of Γ -space pixel amplitudes of said first output color data plane to produce a corresponding row of bandpass filtered Γ -space pixel amplitudes;

5 means for combining said bandpass filtered pixel rows and columns to produce two-dimensionally bandpass filtered Γ -space pixel amplitudes;

means for paring said two-dimensionally bandpass filtered Γ -space amplitudes whereby to boost
10 high spatial frequency components having lower amplitudes and suppress high spatial frequency components having higher amplitudes; and

means for adding the Γ -space pixel amplitudes produced by said means for paring to amplitudes of
15 corresponding pixels in each of said first, second and third output color data planes.

63. The apparatus of Claim 62 wherein said columns of bandpass filtered amplitudes have greater high spatial
20 frequency noise than said rows of bandpass filtered amplitudes, said apparatus further comprising:

means for low pass filtering said columns of bandpass filtered amplitudes.

25 64. The apparatus of Claim 62 further comprising means for output color adjusting said amplitudes of the pixels of said output color data planes.

65. The apparatus of Claim 55 wherein said
30 compressed data comprises compressed normalized spatial frequency coefficients and wherein said means for decompressing comprises:

1) means for producing decompressed normalized coefficients from said compressed normalized
35 coefficients,

2) means for denormalizing said decompressed coefficients in accordance with a cascaded modulation transfer function corresponding to modulation transfer functions of selected elements of said apparatus, whereby
5 to produce denormalized spatial frequency coefficients,
3) means for back-transforming respective transform blocks of the denormalized spatial frequency coefficients to blocks of pixel amplitudes whereby to produce said first, second and third decompressed color
10 data planes.

66. The apparatus of Claim 65 wherein said means for producing decompressed normalized coefficients comprises:

15 means for decoding said recorded data in accordance with a minimum redundancy code whereby to produce said decompressed normalized spatial frequency coefficients; and

wherein said means for denormalizing comprise:

20 means for multiplying said decompressed normalized spatial frequency coefficients by corresponding elements of a normalization array corresponding to said cascaded modulation transfer function whereby to produce said denormalized spatial
25 frequency coefficients.

67. The apparatus of Claim 66 further comprising means for displaying an image comprising pixel amplitudes produced by the back-transforming means, wherein said
30 cascaded modulation transfer function corresponds to modulation transfer functions of said means for edge enhancing and of said means for displaying.

68. The apparatus of Claim 67 wherein said cascaded modulation transfer function further corresponds to a human visual contrast sensitivity function.

5 69. The apparatus of Claim 68 further comprising means for producing said normalization array corresponding to said cascaded modulation transfer function, comprising:

 means for determining from the number of pixel
10 rows and pixel columns in each of said transform blocks the number of cycles per pixel of each of said spatial frequency coefficients and means for associating each coefficient with a value of a modulation transfer function of said edge enhancing means at a corresponding
15 spatial frequency in cycles per pixel whereby to form an edge enhancement modulation transfer function array;

 means for determining from pixel spacing corresponding to said means for displaying the number of cycles per unit distance of each of said spatial
20 frequency coefficients and means for associating each coefficient with a value of a modulation transfer function of said displaying means at a corresponding spatial frequency in cycles per unit distance whereby to form a display modulation transfer function array;

25 means for determining from a viewing distance corresponding to said displaying means the number of cycles per degree of visual scan of each of said spatial frequency coefficients and means for associating each coefficient with a value of a human visual contrast
30 sensitivity function at a corresponding spatial frequency in cycles per degree whereby to form a human visual contrast sensitivity function array;

 means for cascading said arrays together whereby to form a cascaded array of plural elements

comprising said cascaded modulation transfer function;
and

means for inverting the elements of said
cascaded array.

5

70. The apparatus of Claim 69 further comprising
means for reducing the bandwidth of said human visual
contrast sensitivity function by a predetermined factor
whenever said means for compressing compresses said
10 second or third input color data planes.

71. The apparatus of Claim 70 wherein the spatial
patterns of the pixels of said three colors in said image
plane are different, whereby said means for determining
15 the number of cycles per unit distance of said spatial
frequency coefficients produce different normalization
arrays depending upon which one of said first, second or
third input color data planes is being compressed.

20 72. The apparatus of Claim 70 wherein said second
and third input color data planes comprise red minus
green and blue minus green color difference signals and
wherein said predetermined factor is 2 for said second
input color data plane and 4 for said third input color
25 data plane.

73. The apparatus of Claim 65 wherein said means
for back-transforming said decompressed spatial frequency
coefficients performs an inverse discrete cosine
30 transform.

74. Apparatus for receiving image data comprising
arrays of compressed normalized spatial frequency
transform coefficients, comprising:

1) means for producing decompressed normalized coefficients from said compressed normalized coefficients;

2) means for denormalizing said decompressed normalized coefficients to produce denormalized coefficients in accordance with a cascaded modulation transfer function representing image output means; and

3) means for back-transforming individual transform blocks of said denormalized spatial frequency coefficients to blocks of pixels.

75. The apparatus of Claim 74 wherein said means for denormalizing comprises:

means for producing a normalization array having plural normalization factors corresponding to said cascaded modulation transfer function; and

means for multiplying each spatial frequency coefficient by a corresponding factor in said normalization array to produce a denormalized coefficient.

76. The apparatus of Claim 75 further comprising means for edge enhancing an image comprising the pixels produced by said means for back-transforming and means for displaying an image comprising the pixels produced by said means for edge enhancing, wherein said cascaded modulation transfer function corresponds to modulation transfer functions of said means for edge enhancing and said means for displaying.

77. The apparatus of Claim 76 wherein said cascaded modulation transfer function further corresponds to a contrast sensitivity function of the human visual system.

78. The apparatus of Claim 77 wherein said means for producing said normalization array corresponding to said cascaded modulation transfer function comprise:

means for determining from the number of pixel
5 rows and columns in each of said transform blocks the number of cycles per pixel of each of said spatial frequency coefficients and means for associating each coefficient with an amplitude of a modulation transfer function of said means for edge enhancing at a
10 corresponding spatial frequency in cycles per pixel whereby to form an edge enhancement modulation transfer function array;

means for determining from pixel spacing
15 corresponding to said means for displaying the number of cycles per unit distance of each of said spatial frequency coefficients and means for associating each coefficient with an amplitude of a modulation transfer function of said displaying means at a corresponding spatial frequency in cycles per unit distance whereby to
20 form a display modulation transfer function array;

means for determining from a viewing distance
25 corresponding to said means for displaying the number of cycles per degree of visual scan of each of said spatial frequency coefficients and means for associating each coefficient with an amplitude of the human visual contrast sensitivity function at a corresponding spatial frequency in cycles per degree whereby to form a visual contrast sensitivity function array;

means for cascading said arrays together to
30 form a cascaded array of plural elements comprising said cascaded modulation transfer function; and

means for inverting each element of the cascaded array.

79. The apparatus of Claim 78 wherein said arrays represent, respectively, a luminance related component and a pair of color difference components of a color image, said apparatus further comprising means for
5 reducing the bandwidth of said human visual contrast sensitivity function by a predetermined factor whenever said means for compressing compresses coefficients of a color difference component.

10 80. The apparatus of Claim 79 wherein the spatial patterns of the pixels of said components are different, whereby said means for determining the number of cycles per unit distance of said spatial frequency coefficients produces different normalization arrays depending upon
15 which one of the arrays of pixels is being compressed.

81. The apparatus of Claim 79 wherein said color difference components comprise red minus green and blue minus green color difference components and wherein said
20 predetermined factor is 2 for the red minus green component and 4 for the blue minus green component.

82. The apparatus of Claim 74 wherein said means for back-transforming said denormalized coefficients
25 comprises means for performing an inverse discrete cosine transform process, and said means for producing said decompressed normalized coefficients comprises means for decoding the data comprising said compressed coefficients in accordance with a minimum redundancy code.

30

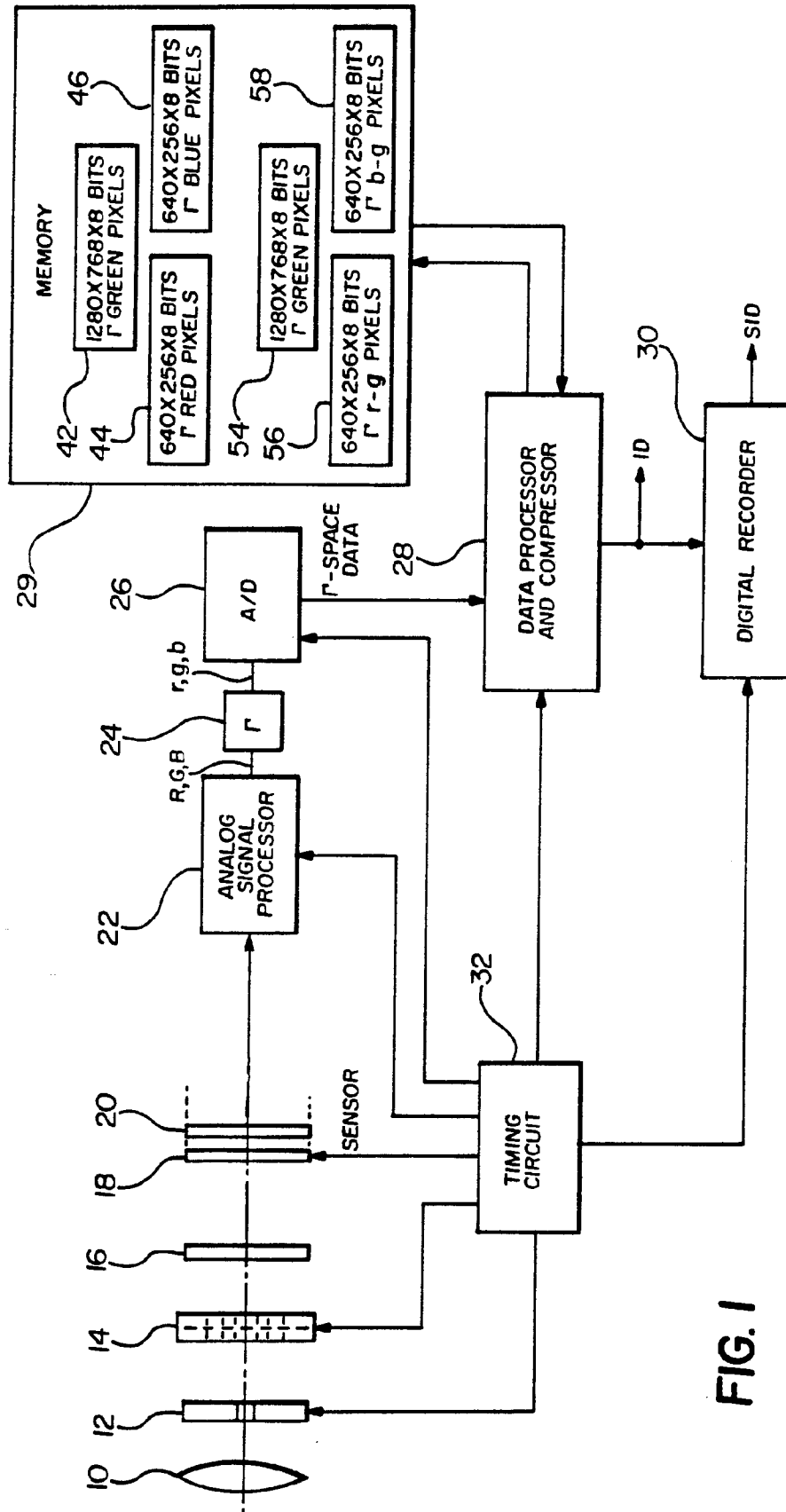

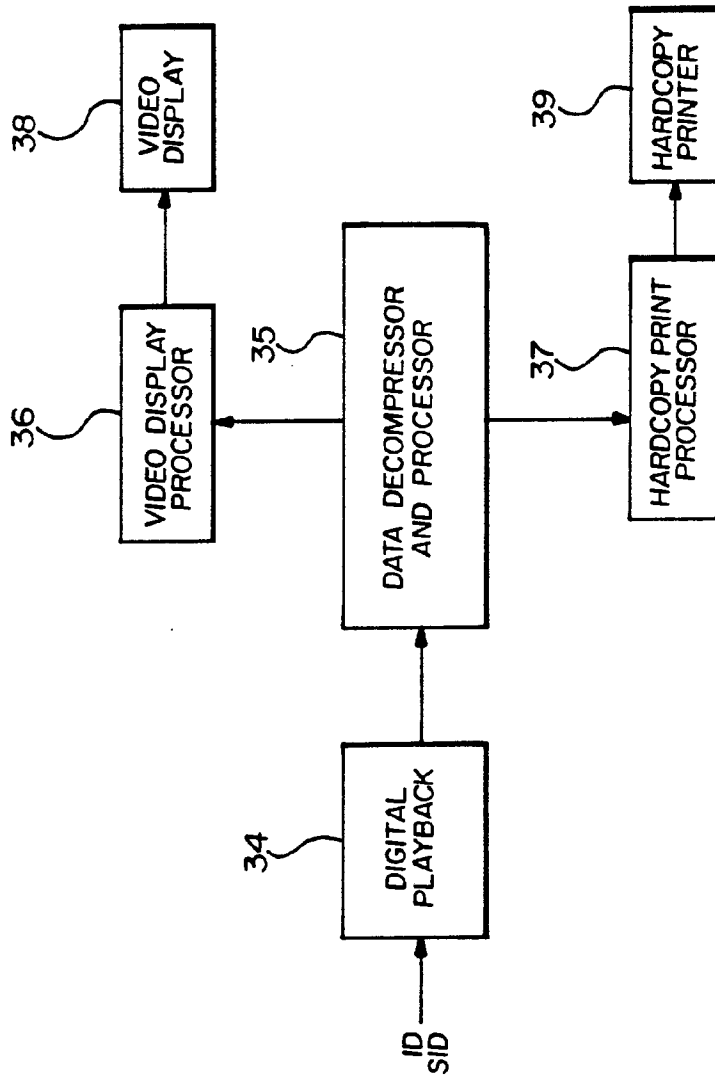

FIG. 2

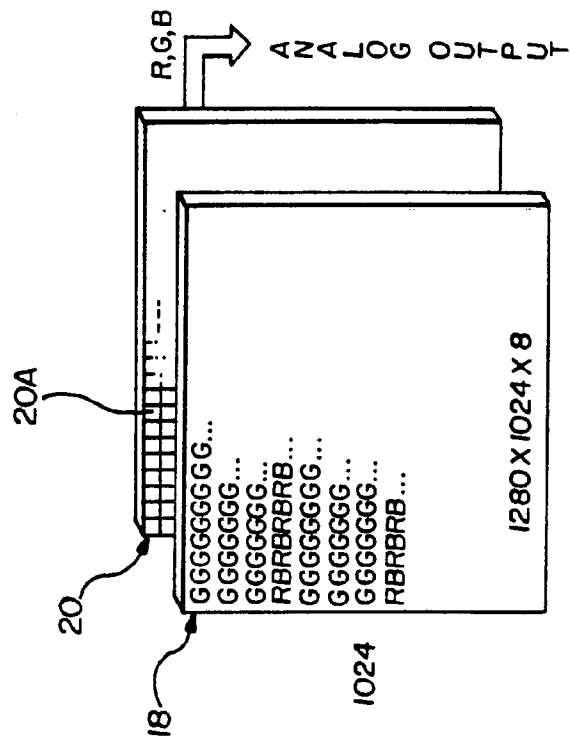

FIG. 3

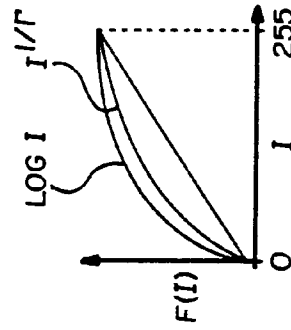

FIG. 4

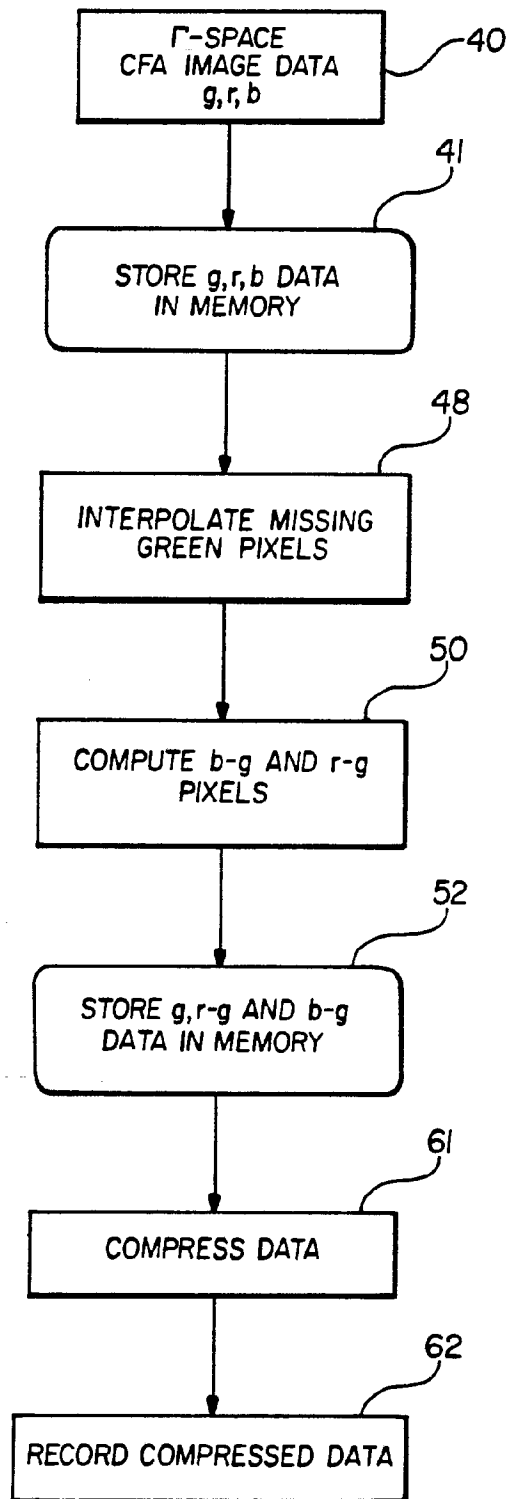

FIG. 5

5/13

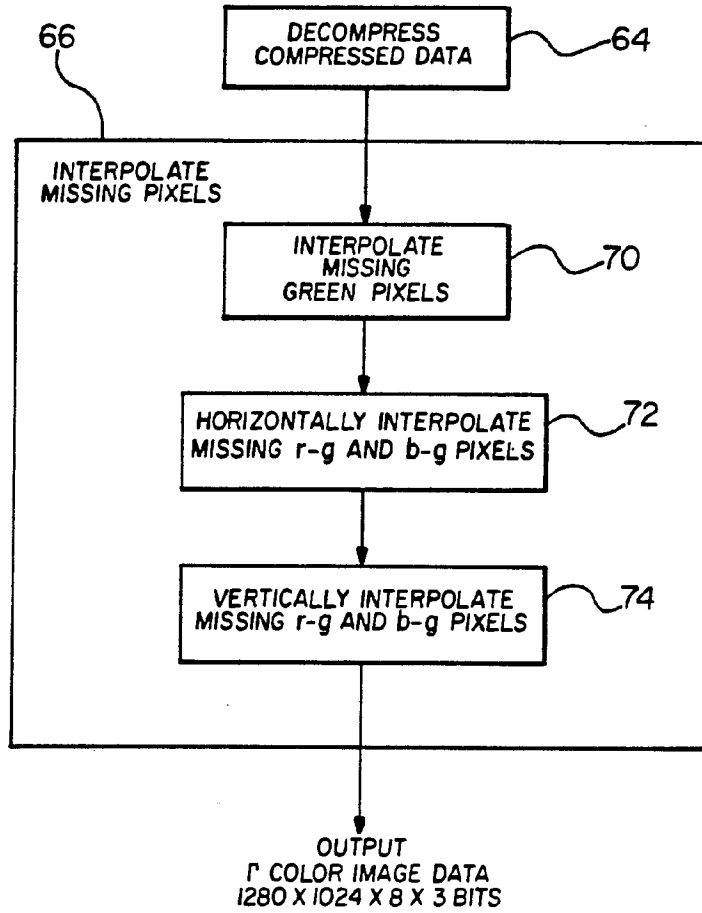

FIG. 6

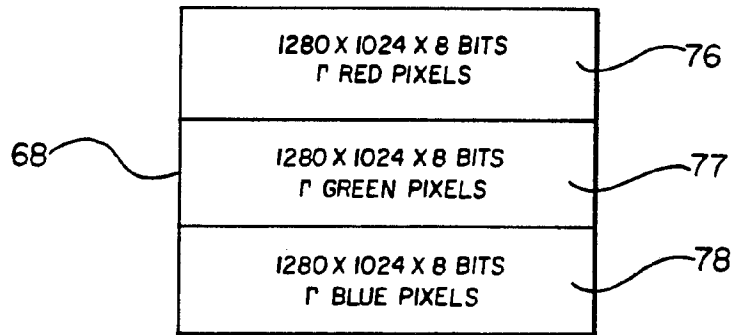

FIG. 7

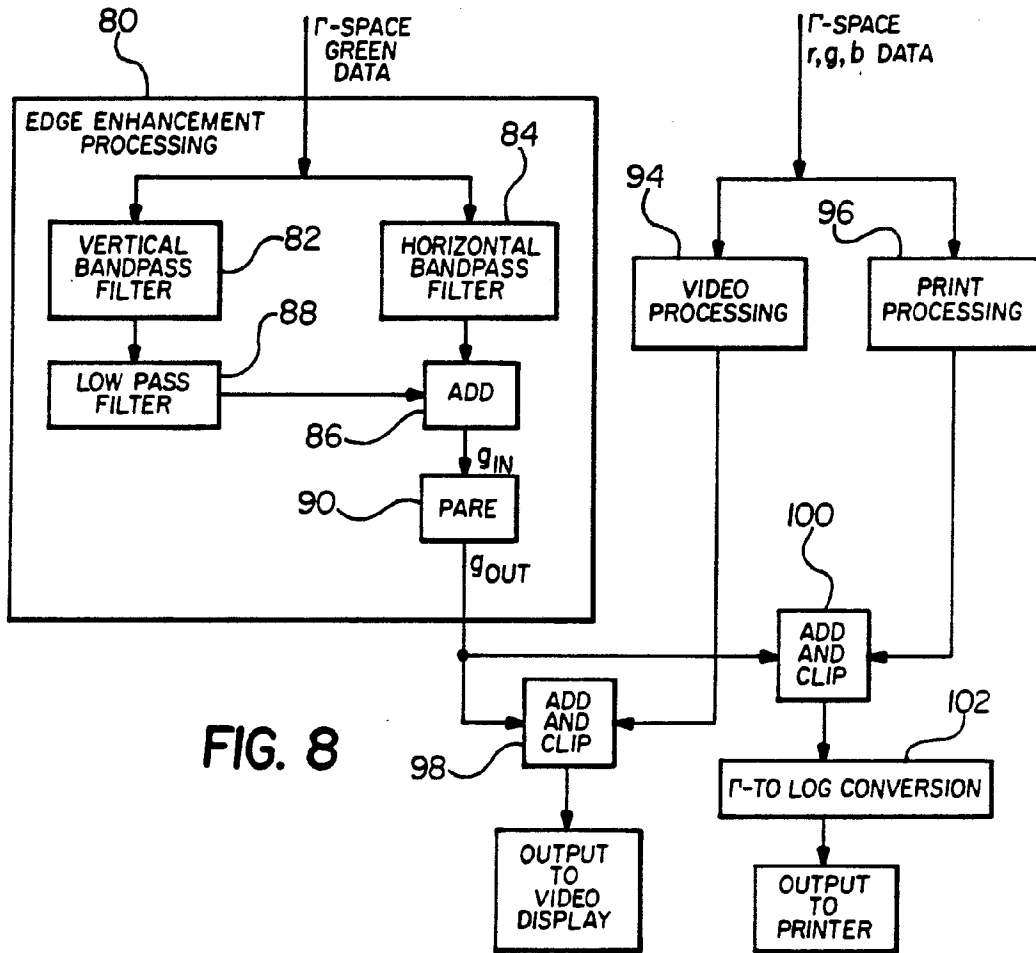

FIG. 8

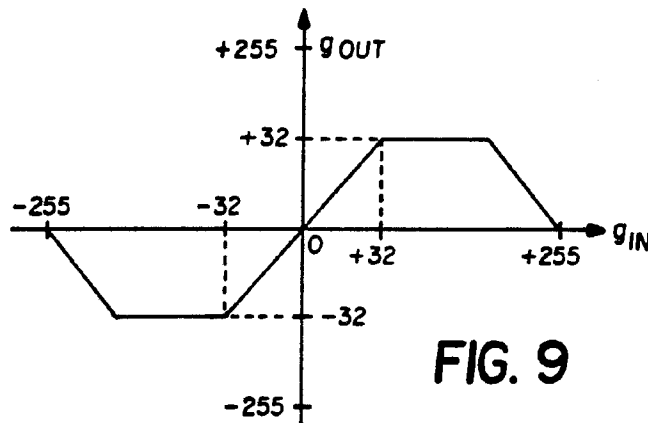

FIG. 9

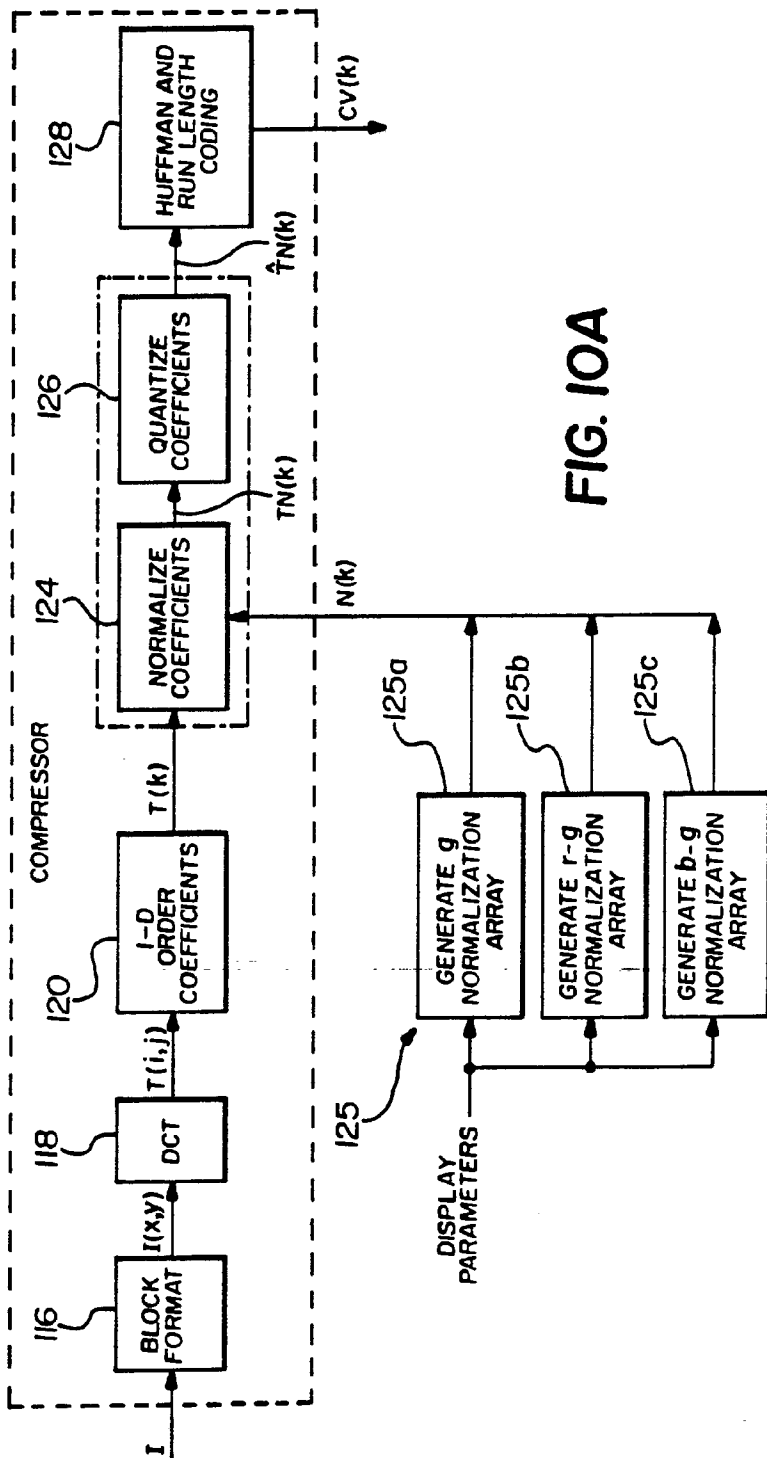
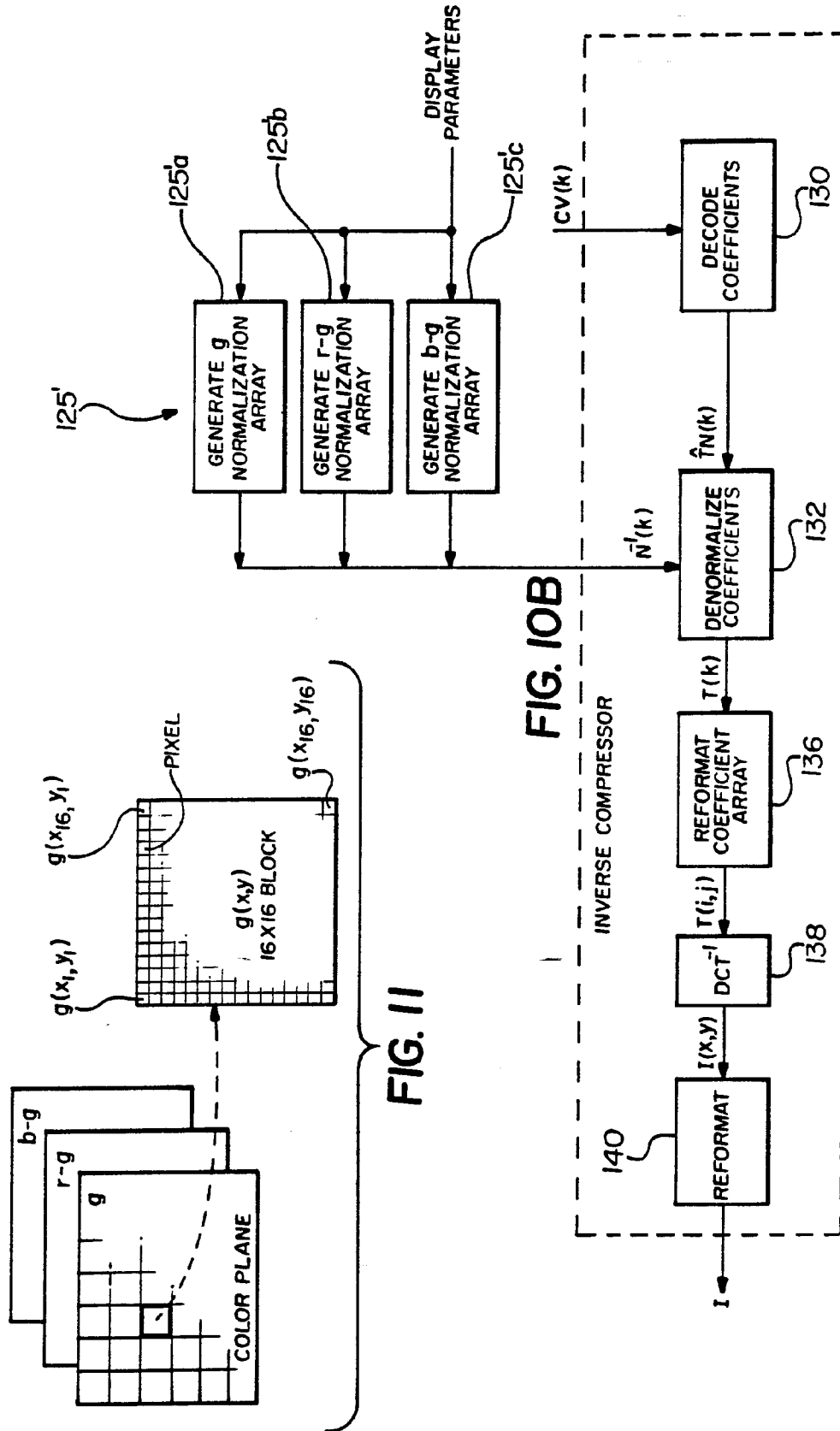
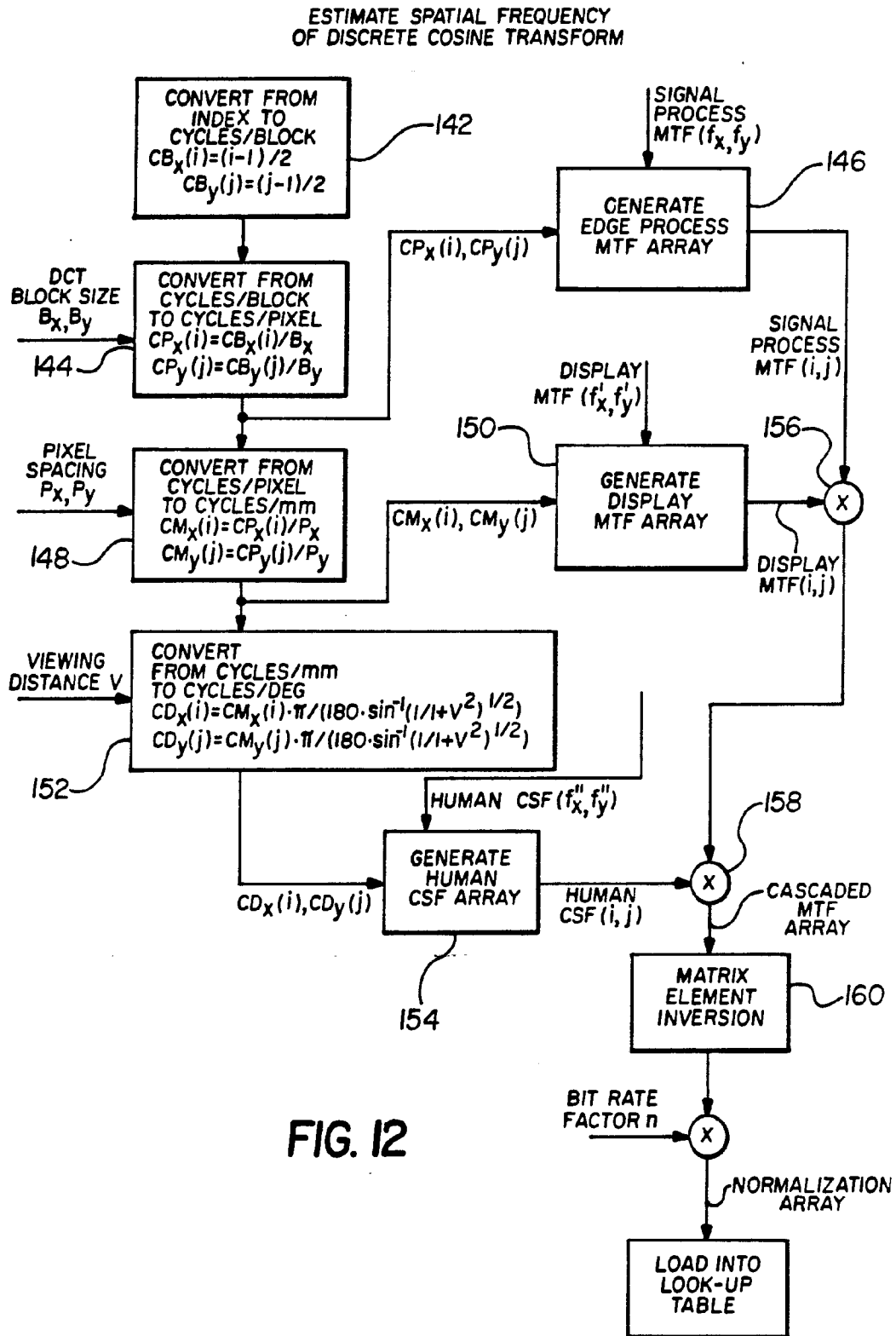

FIG. 10A





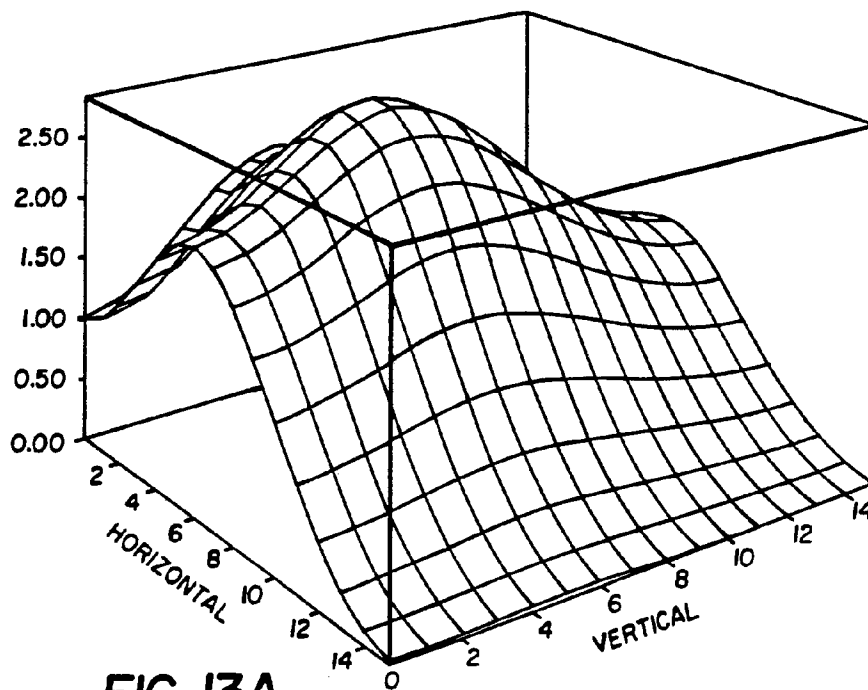

FIG. 13A

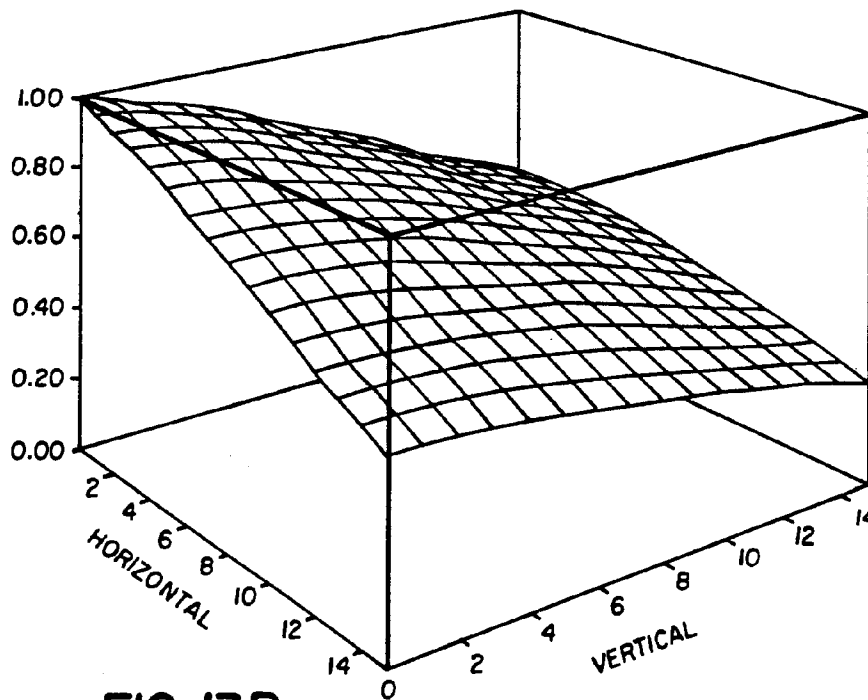
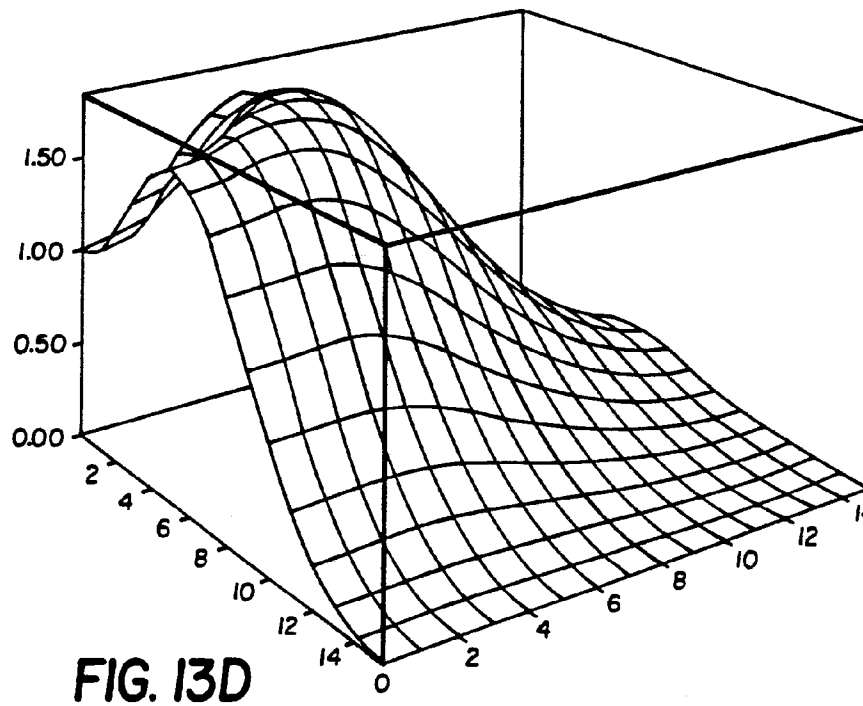
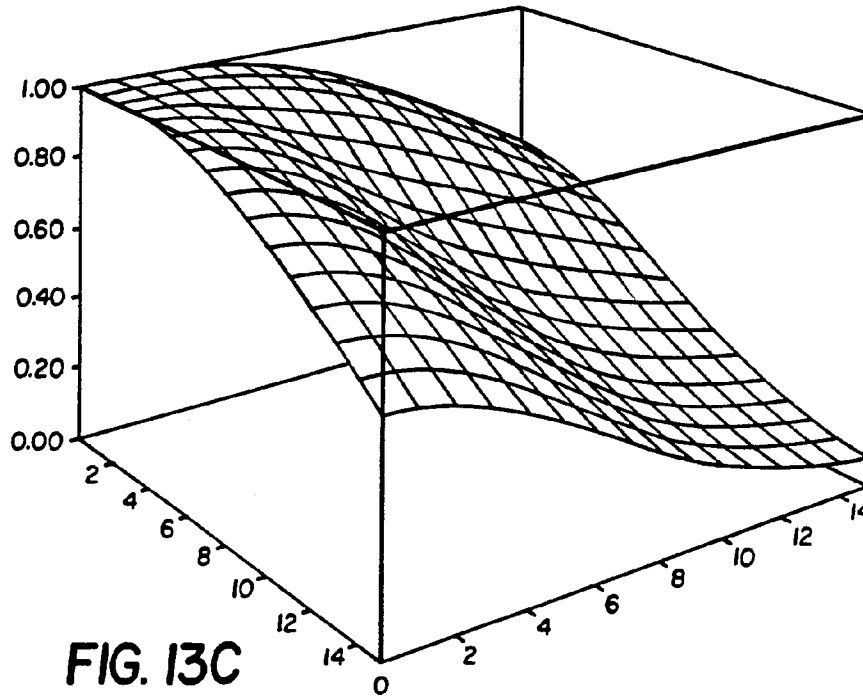
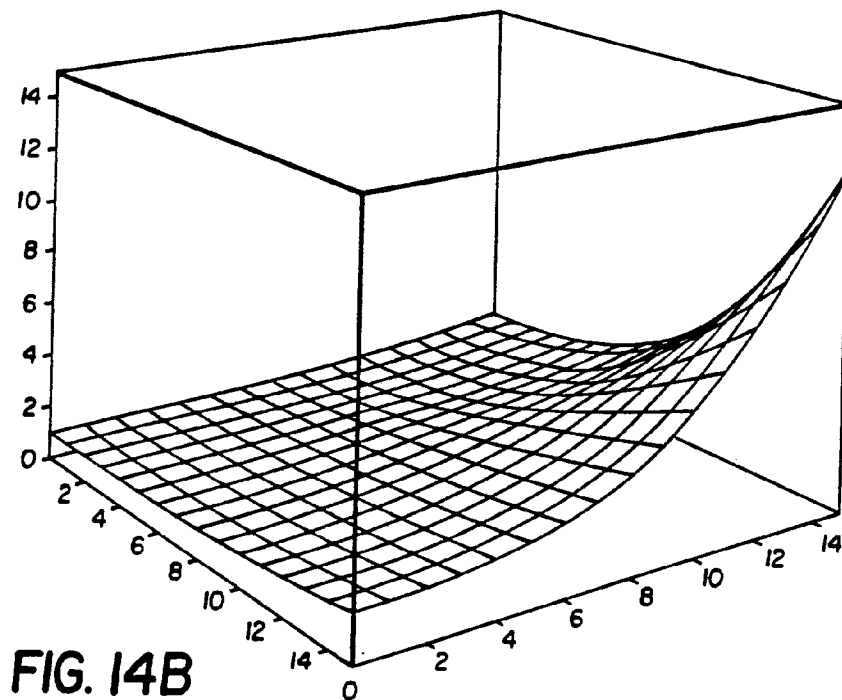
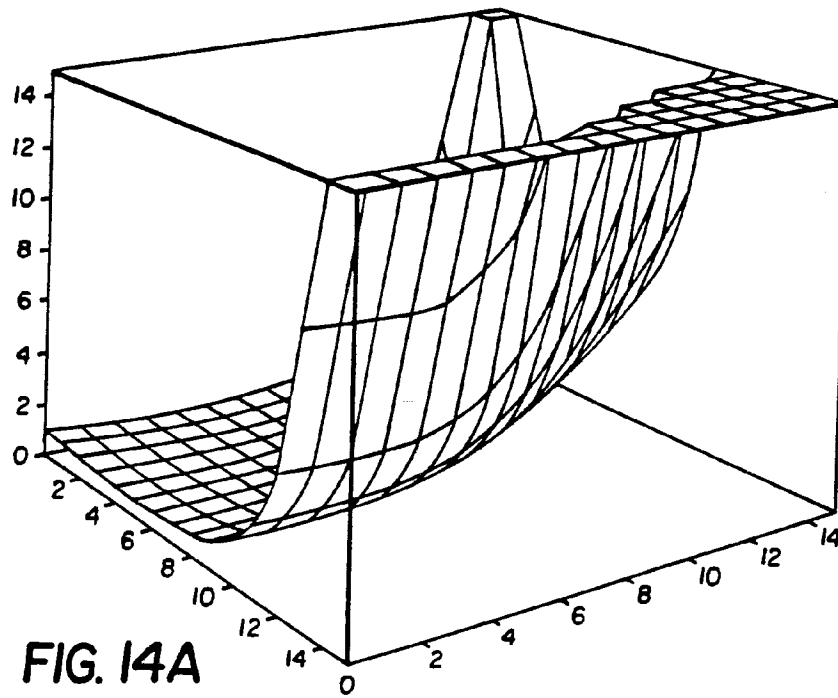
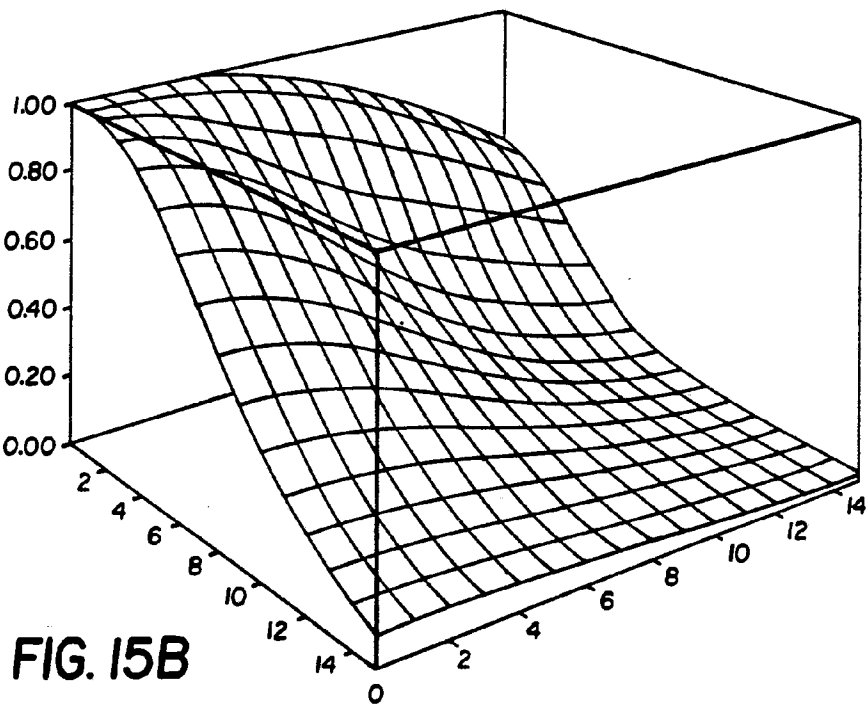
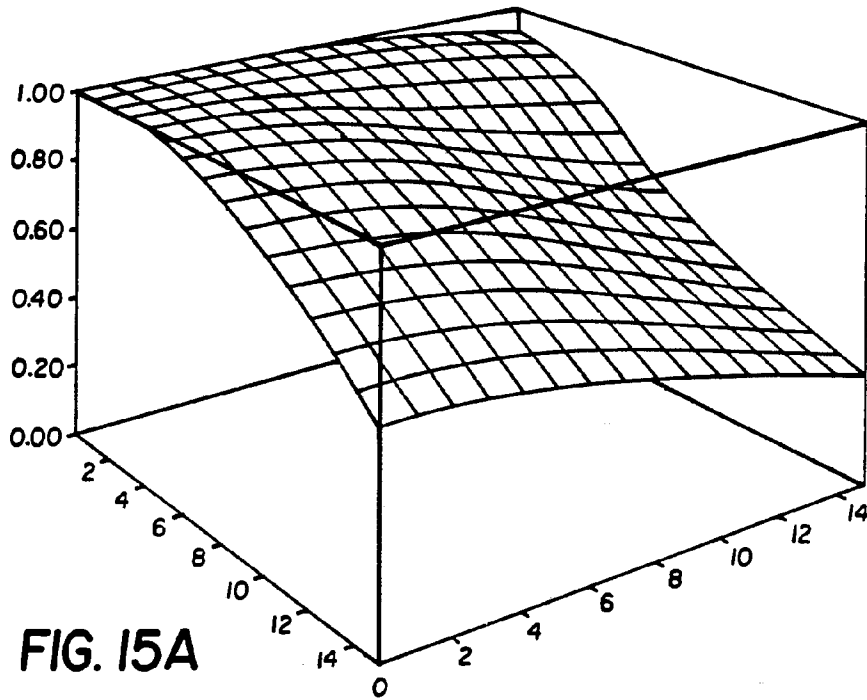

FIG. 13B







INTERNATIONAL SEARCH REPORT

International Application No

PCT/US 91/08767

I. CLASSIFICATION OF SUBJECT MATTER (if several classification symbols apply, indicate all) ⁶		
According to International Patent Classification (IPC) or to both National Classification and IPC		
IPC ⁵ : H 04 N 11/04, H 04 N 7/133, H 04 N 9/04		
II. FIELDS SEARCHED		
Minimum Documentation Searched ⁷		
Classification System	Classification Symbols	
IPC ⁵	H 04 N 3/00, H 04 N 5/00, H 04 N 7/00, H 04 N 9/00, H 04 N 11/00	
Documentation Searched other than Minimum Documentation to the extent that such Documents are included in the Fields Searched ⁸		
III. DOCUMENTS CONSIDERED TO BE RELEVANT⁹		
Category ¹⁰	Citation of Document, ¹¹ with indication, where appropriate, of the relevant passages ¹²	Relevant to Claim No. ¹³
A	US, A, 4 614 966 (YUNOKI) 30 September 1986 (30.12.86), see fig. 1,7; column 2, line 30 - column 4, line 8. --	1-3, 34, 35, 36, 55, 56, 67
A	EP, A1, 0 390 421 (CANON) 03 October 1990 (03.10.90), see fig. 1; column 3, line 12 - column 4, line 25. --	1, 11, 21, 30, 34, 37, 46, 74
A	EP, A2, 0 304 643 (POLAROID) 01 March 1989 (01.03.89), see abstract. --	1, 2, 34, 35
A	GB, A, 737 351 (SYLVANIA) 21 September 1955 (21.09.55), see fig. 1; page 2, lines 85-87.	1, 2, 34, 35
<p>¹⁰ Special categories of cited documents: ¹⁰</p> <p>"A" document defining the general state of the art which is not considered to be of particular relevance</p> <p>"E" earlier document but published on or after the international filing date</p> <p>"L" document which may throw doubts on priority claim(s) or which is cited to establish the publication date of another citation or other special reason (as specified)</p> <p>"O" document referring to an oral disclosure, use, exhibition or other means</p> <p>"P" document published prior to the international filing date but later than the priority date claimed</p> <p>"T" later document published after the international filing date or priority date and not in conflict with the application but cited to understand the principle or theory underlying the invention</p> <p>"X" document of particular relevance; the claimed invention cannot be considered novel or cannot be considered to involve an inventive step</p> <p>"Y" document of particular relevance; the claimed invention cannot be considered to involve an inventive step when the document is combined with one or more other such documents, such combination being obvious to a person skilled in the art.</p> <p>"Z" document member of the same patent family</p>		
IV. CERTIFICATION		
Date of the Actual Completion of the International Search	Date of Mailing of this International Search Report	
30 March 1992	- 7. 04. 92	
International Searching Authority	Signature of Authorized Officer	
EUROPEAN PATENT OFFICE	Maria Peis <i>Maria Peis</i>	

Form PCT/ISA/210 (second sheet) (January 1985)

III. DOCUMENTS CONSIDERED TO BE RELEVANT (CONTINUED FROM THE SECOND SHEET)		
Category *	Citation of Document, " with indication, where appropriate, of the relevant passages	Relevant to Claim No.
A	<p style="text-align: center;">---</p> EP, A2, 0 211 320 (POLAROID) 25 February 1987 (25.02.87), see abstract; column 4, line 37 - column 5, line 4.	1,34
P,A	<p style="text-align: center;">---</p> WO, A1, 91/01 613 (EASTMAN KODAK) 07 February 1991 (07.02.91), see totality.	1-3,7, 11,12, 16,18, 20-22, 25,26, 30,46, 47,50, 54,74, 82
A	<p style="text-align: center;">---</p> US, A, 4 780 761 (DALY) 25 October 1988 (25.10.88), see fig. 1; column 2, line 65 - column 4; line 17 (cited in the application).	46,50, 54,74, 82

ANHANG

ANNEX

ANNEXE

zum internationalen Recherchenbericht über die internationale Patentanmeldung Nr.

to the International Search Report to the International Patent Application No.

au rapport de recherche international relatif à la demande de brevet international n°

PCT/US91/08767 SAE 55179

In diesem Anhang sind die Mitglieder der Patentfamilien der im obengenannten internationalen Recherchenbericht angeführten Patentdokumente angegeben. Diese Angaben dienen nur zur Unterrichtung und erfolgen ohne Gewähr.

This Annex lists the patent family members relating to the patent documents cited in the above-mentioned international search report. The Office is in no way liable for these particulars which are given merely for the purpose of information.

La présente annexe indique les membres de la famille de brevets relatifs aux documents de brevets cités dans le rapport de recherche international visée ci-dessus. Les renseignements fournis sont donnés à titre indicatif et n'engagent pas la responsabilité de l'Office.

In Recherchenbericht angeführtes Patentdokument Patent document cited in search report Document de brevet cité dans le rapport de recherche	Datum der Veröffentlichung Publication date Date de publication	Mitglied(er) der Patentfamilie Patent family member(s) Membre(s) de la famille de brevets	Datum der Veröffentlichung Publication date Date de publication
US A 4614966	30-09-86	DE C0 3381463 EP A2 102030 EP A3 102030 EP B1 102030 JP A2 59034772	17-05-90 07-03-84 08-10-86 11-04-90 25-02-84
EP A1 390421	03-10-90	CA AA 2012966 JP A2 2305189 JP A2 2257780	30-09-90 18-12-90 18-10-90
EP A2 304643	01-03-89	CA A1 1287163 EP TD 304643 EP A3 304643 JP A2 1059470 US A 4774565	30-07-91 22-06-89 20-09-89 07-03-89 27-09-88
GB A 737351		keine - none - rien	
EP A2 211320	25-02-87	CA A1 1252200 DE C0 3682547 EP A3 211320 EP B1 211320 JP A2 62034484 US A 4663655 US A 4724395	04-04-89 02-01-92 20-07-88 21-11-91 14-02-87 05-05-87 09-02-88
WD A1 9101613	07-02-91	EP A1 436012 US A 5053861 US A 5065229	10-07-91 01-10-91 12-11-91
US A 4780761	25-10-88	EP A1 316419 JP T2 1503588 WD A1 8810050	24-05-89 30-11-89 15-12-88

KOREAN PATENT ABSTRACTS

(11) Publication number: 1020090035204 A

(43) Publication date: 09.04.2009

(21) Application number: 1020070100345

(22) Application date: 05.10.2007

(71) Applicant:

• SAMSUNG
ELECTRONICS
CO., LTD.

(72) Inventor:

• KIM, JUNG YEON
• TANAKA HIROMICHI
• KIM, JIN HAK

(51) Int. Cl: H04N 5/335 (2006.01)

(54) SOLID IMAGING APPARATUS IMPROVING A PATTERN AND SIGNAL PROCESSING OPERATION OF A COLOR FILTER, A PIXEL ARRAY METHOD OF THE SOLID IMAGING APPARATUS AND A SIGNAL PROCESSING METHOD OF A SOLID IMAGING APPARATUS

(57) Abstract:

<SEC> PURPOSE: A solid imaging apparatus, a pixel array method of a solid imaging apparatus and a signal processing method of a solid imaging apparatus are provided to improve the problem of crosstalk and the deterioration of sensibility.

CONSTITUTION: A pixel array(110) senses a yellow color, a green color and a cyan color with sensing. The array of pixel comprises a plurality of pixel rows arranged as the vertical direction of the array. In the first pixel row among the pixel row, the pixel sensing the same first color is arranged. The pixel sensing the second color and the pixel sensing the third color is arranged in the second pixel row among the pixel row. The first pixel row and the second pixel row are arranged to be adjacent to the horizontal direction of the array. A color correction unit(130) removes cross-talk about the signal outputted from the interpolator(120).

© KIPO 2009 </SEC>



(19) 대한민국특허청(KR)
(12) 공개특허공보(A)

(11) 공개번호 10-2009-0035204
(43) 공개일자 2009년04월09일

(51) Int. Cl.

H04N 5/335 (2006.01)

(21) 출원번호 10-2007-0100345

(22) 출원일자 2007년10월05일

심사청구일자 없음

(71) 출원인

삼성전자주식회사

경기도 수원시 영통구 매탄동 416

(72) 발명자

김정연

부산 부산진구 개금3동 개금반도보라아파트
101-1802

다나카 히로미치

경기 수원시 팔달구 영통동 958-2 웨미리타워 82
5호

김진학

서울 동작구 사당동 1027-22번지 101호

(74) 대리인

리엔특허법인

전체 청구항 수 : 총 37 항

(54) 고체 촬상 장치, 고체 촬상 장치의 픽셀 배열 방법 및 고체촬상 장치의 신호 처리 방법

(57) 요약

크로스 토크(Crosstalk) 성분 및 위색신호를 효과적으로 제거할 수 있는 고체 촬상장치, 고체 촬상 장치의 픽셀 배열 방법 및 고체 촬상 장치의 신호 처리 방법이 개시된다. 상기 고체 촬상 장치의 일실시에 따르면, 적어도 황색(Yellow) 칼라, 녹색(Green) 칼라 및 사이언(Cyan) 칼라를 센싱하는 픽셀 어레이 및 상기 픽셀 어레이로부터 제공되는 이미지 신호를 입력받아 소정의 연산 동작을 수행하는 칼라 보정부를 구비하며, 상기 픽셀 어레이는, 어레이의 수직방향으로 동일한 제1 칼라를 센싱하는 픽셀들이 배치되는 제1 픽셀열과, 어레이의 수직방향으로 제2 칼라를 센싱하는 픽셀과 제3 칼라를 센싱하는 픽셀이 교대로 배치되는 제2 픽셀열을 구비하는 것을 특징으로 한다.

대표도

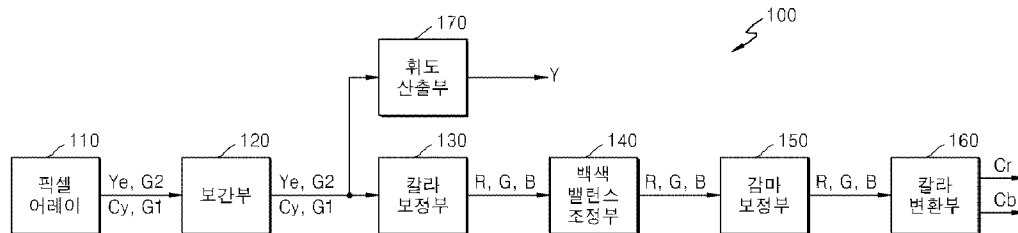

특허청구의 범위

청구항 1

적어도 황색(Yellow) 칼라, 녹색(Green) 칼라 및 사이언(Cyan) 칼라를 센싱하는 픽셀 어레이; 및
 상기 픽셀 어레이로부터 제공되는 이미지 신호를 입력받아 소정의 연산 동작을 수행하는 칼라 보정부를 구비하며,
 상기 픽셀 어레이는, 어레이의 수직방향으로 동일한 제1 칼라를 센싱하는 픽셀들이 배치되는 제1 픽셀열과, 어레이의 수직방향으로 제2 칼라를 센싱하는 픽셀과 제3 칼라를 센싱하는 픽셀이 교대로 배치되는 제2 픽셀열을 구비하는 것을 특징으로 하는 고체 촬상 장치.

청구항 2

제1항에 있어서,
 상기 제1 픽셀열과 상기 제2 픽셀열은, 어레이의 수평 방향으로 서로 인접하게 배치되는 것을 특징으로 하는 고체 촬상 장치.

청구항 3

제2항에 있어서,
 상기 어레이의 수평 방향으로 상기 제1 픽셀열과 상기 제2 픽셀열이 교대로 배치되는 것을 특징으로 하는 고체 촬상 장치.

청구항 4

제1항에 있어서,
 상기 제1 칼라는 녹색(Green) 칼라이며, 상기 제2 칼라는 황색(Yellow) 칼라이고, 상기 제3 칼라는 사이언(Cyan) 칼라인 것을 특징으로 하는 고체 촬상 장치.

청구항 5

제1항에 있어서, 상기 칼라 보정부는,
 황색(Yellow) 칼라신호, 사이언(Cyan) 칼라신호, 상기 사이언(Cyan) 칼라신호에 수평방향으로 인접하는 제1 녹색(Green) 칼라신호 및 상기 황색(Yellow) 칼라신호에 수평방향으로 인접하는 제2 녹색(Green) 칼라신호를 입력받으며, 상기 입력된 신호들에 대한 연산 동작을 수행하여 적(Red), 녹(Green), 청(Blue)의 칼라 신호를 산출하는 것을 특징으로 하는 고체 촬상 장치.

청구항 6

제5항에 있어서, 상기 칼라 보정부는,
 상기 입력된 황색(Yellow) 칼라신호, 제1, 제2 녹색(Green) 칼라신호 및 사이언(Cyan) 칼라신호를 선택적으로 연산함으로써, 상기 신호들 내에 포함되는 크로스 토크(Crosstalk) 성분을 감소시키는 것을 특징으로 하는 고체 촬상 장치.

청구항 7

제6항에 있어서, 상기 칼라 보정부는,
 상기 크로스 토크(Crosstalk) 성분을 감소시키기 위하여, 상기 황색(Yellow) 칼라신호와 상기 제1 녹색(Green) 칼라신호를 서로 연산하는 제1 과정과, 상기 사이언(Cyan) 칼라신호와 상기 제2 녹색(Green) 칼라신호를 서로 연산하는 제2 과정 및 상기 제1 녹색(Green) 칼라신호와 상기 제2 녹색(Green) 칼라신호를 서로 연산하는 제3 과정들 중 적어도 하나의 과정을 포함하는 것을 특징으로 하는 고체 촬상 장치.

청구항 8

제7항에 있어서, 상기 칼라 보정부는,
 상기 제1 과정은, 상기 황색(Yellow) 칼라신호에서 상기 제1 녹색(Green) 칼라신호를 감산하는 과정이고,
 상기 제2 과정은, 상기 사이언(Cyan) 칼라신호에서 상기 제2 녹색(Green) 칼라신호를 감산하는 과정이며,
 상기 제3 과정은, 상기 제1 녹색(Green) 칼라신호와 상기 제2 녹색(Green) 칼라신호의 평균을 구하는 과정인 것을 특징으로 하는 고체 촬상 장치.

청구항 9

제5항에 있어서, 상기 칼라 보정부는,
 상기 입력된 신호들에 포함된 크로스 토크(Crosstalk) 성분을 감소시키기 위한 연산을 수행하는 크로스 토크 보정회로; 및
 상기 크로스 토크 보정회로로부터 보정된 신호를 입력받아 이를 표준 이미지 신호로 보정하는 색 보정 매트릭스(Matrix) 회로를 구비하는 것을 특징으로 하는 고체 촬상 장치.

청구항 10

제1항에 있어서,
 상기 픽셀 어레이 및 상기 칼라 보정부 사이에 배치되며, 상기 픽셀 어레이로부터 칼라 신호를 입력받아 이에 대한 보간(Interpolation) 동작을 수행하는 보간부를 더 구비하는 것을 특징으로 하는 고체 촬상 장치.

청구항 11

제10항에 있어서,
 상기 픽셀 어레이로부터 제공되는 칼라 신호를 이용하여 이미지의 휘도 성분을 산출하기 위한 휘도 산출부를 더 구비하는 것을 특징으로 하는 고체 촬상 장치.

청구항 12

제11항에 있어서,
 상기 휘도 산출부는 상기 보간부에서 출력되는 보간동작 수행된 칼라 신호를 입력받는 것을 특징으로 하는 고체 촬상 장치.

청구항 13

제11항에 있어서, 상기 휘도 산출부는,
 입력된 칼라 신호에 각각에 대하여 소정의 계수를 승산하기 위한 승산기;
 상기 승산기로부터 승산 처리된 칼라 신호를 입력받아, 이에 대한 가산 동작을 수행하여 휘도신호를 산출하는 가산기; 및
 상기 가산기로부터 제공된 휘도신호를 입력받아 게인(gain)을 조절하는 게인 조절부를 구비하는 것을 특징으로 하는 고체 촬상 장치.

청구항 14

제13항에 있어서, 상기 게인 조절부는,
 상기 칼라 신호에 대한 보정 처리를 수행하는 과정에서 발생하는 신호의 레벨 변동에 대응하여 상기 휘도신호의 레벨을 조절하는 것을 특징으로 하는 고체 촬상 장치.

청구항 15

제13항에 있어서, 상기 휘도 산출부는,

상기 칼라 신호에 대한 감마 보정을 수행하는 과정에서 발생하는 신호의 레벨 변동에 대응하여 상기 휘도신호의 레벨을 조절하기 위한 감마 보정부를 더 구비하는 것을 특징으로 하는 고체 촬상 장치.

청구항 16

제1항에 있어서,

상기 고체 촬상 장치는 CMOS 이미지 센서인 것을 특징으로 하는 고체 촬상 장치.

청구항 17

적어도 황색(Yellow) 칼라, 녹색(Green) 칼라 및 사이언(Cyan) 칼라를 센싱하는 픽셀 어레이; 및

상기 픽셀 어레이로부터 제공되는 이미지 신호에 포함된 크로스 토크(Crosstalk) 성분을 감소시키는 칼라 보정부를 구비하며,

상기 픽셀 어레이는, 수직 방향으로 두 개의 픽셀과 수평 방향으로 두 개의 픽셀에 해당하는 크기를 갖는 픽셀 그룹을 복수 개 구비하고, 상기 픽셀 그룹 각각은 제1 칼라를 센싱하는 두 개의 픽셀과 제2 칼라를 센싱하는 하나의 픽셀 및 제3 칼라를 센싱하는 하나의 픽셀을 포함하며, 상기 제1 칼라를 센싱하는 두 개의 픽셀은 수직 방향으로 인접하게 배치되는 것을 특징으로 하는 고체 촬상 장치.

청구항 18

제17항에 있어서,

상기 제1 칼라는 녹색(Green) 칼라이며, 상기 제2 칼라는 황색(Yellow) 칼라이고, 상기 제3 칼라는 사이언(Cyan) 칼라인 것을 특징으로 하는 고체 촬상 장치.

청구항 19

복수의 행 및 복수의 열 방향으로 배치되는 픽셀들을 포함하는 픽셀 어레이;

상기 픽셀 어레이로부터 제공된 칼라 신호에 대해 보간 동작을 수행하는 보간부; 및

상기 보간부로부터 보간 처리된 칼라 신호를 입력받으며, 동일한 칼라의 신호를 서로 연산함에 기반하여 위색신호를 포함하는 픽셀들의 위치를 검출하고 이에 따른 보정신호를 발생하며, 상기 보간 처리된 칼라신호에 대해 상기 보정신호에 기반하여 가산 연산 및/또는 감산 연산을 수행함으로써 상기 위색신호를 제거하는 위색신호 제거부를 구비하는 것을 특징으로 하는 고체 촬상 장치.

청구항 20

제19항에 있어서, 상기 픽셀 어레이는,

적어도 황색(Yellow) 칼라, 녹색(Green) 칼라 및 사이언(Cyan) 칼라를 센싱하는 픽셀들을 포함하는 것을 특징으로 하는 고체 촬상 장치.

청구항 21

제20항에 있어서, 상기 픽셀 어레이는,

어레이의 수직방향으로 동일한 녹색(Green) 칼라를 센싱하는 픽셀들이 배치되는 제1 픽셀열과, 어레이의 수직방향으로 황색(Yellow) 칼라를 센싱하는 픽셀과 사이언(Cyan) 칼라를 센싱하는 픽셀이 교대로 배치되는 제2 픽셀열을 구비하는 것을 특징으로 하는 고체 촬상 장치.

청구항 22

제21항에 있어서, 상기 픽셀 어레이는,

상기 어레이의 수평 방향으로 상기 제1 픽셀열과 상기 제2 픽셀열이 교대로 배치되는 것을 특징으로 하는 고체 촬상 장치.

청구항 23

제19항에 있어서, 상기 위색신호 제거부는,

상기 보간 처리된 칼라 신호를 입력받아, 이에 대해 감산 및/또는 가산 연산을 통하여 위색신호를 포함하는 픽셀들의 위치를 검출하고, 이에 따른 보정신호를 발생하는 보정신호 발생부; 및

상기 보간 처리된 칼라 신호를 입력받으며, 상기 위치 검출 결과에 기반하여 상기 검출된 위치 근방의 픽셀들을 이용하여 평균 칼라 신호를 산출하고, 상기 보정신호에 응답하여 상기 보간 처리된 칼라 신호와 상기 평균 칼라 신호를 서로 합산하거나 감산함으로써 상기 위색신호를 제거하는 오차 보정부를 구비하는 것을 특징으로 하는 고체 촬상 장치.

청구항 24

제23항에 있어서,

상기 픽셀 어레이는, 수평 방향으로 제1 칼라를 센싱하는 제1 픽셀과 제2 칼라를 센싱하는 제2 픽셀이 교대로 배치되며,

상기 보정신호 발생부는, 제1 칼라 신호들을 서로 감산 연산하여 제1 신호를 발생하고, 제2 칼라 신호들을 서로 감산 연산하여 제2 신호를 발생하며, 상기 제1 신호 및 제2 신호를 서로 합산하여 제3 신호를 발생하고, 상기 제3 신호를 상기 어레이의 왼쪽 방향 또는 오른쪽 방향으로 쉬프트(sift)시켜 제4 신호를 발생하며, 상기 제4 신호의 일부 신호 레벨을 반전시킴으로써 상기 보정신호를 발생하는 것을 특징으로 하는 고체 촬상 장치.

청구항 25

제24항에 있어서, 상기 오차 보정부는,

상기 위치 검출 결과에 기반하여, 제1 픽셀에 대응하는 제2 칼라의 평균 신호 및 제3 칼라의 평균 신호를 산출하고, 제2 픽셀에 대응하는 제1 칼라의 평균 신호 및 제3 칼라의 평균 신호를 산출하는 것을 특징으로 하는 고체 촬상 장치.

청구항 26

제25항에 있어서, 상기 오차 보정부는,

상기 제1 픽셀에 대응하는 보정신호가 제1 레벨인 경우, 상기 제1 픽셀로부터의 보간 처리된 칼라 신호와 상기 제1 픽셀에 대응하는 평균 신호를 서로 합산하고,

상기 제1 픽셀에 대응하는 보정신호가 제2 레벨인 경우, 상기 제1 픽셀로부터의 칼라 신호에서 상기 제1 픽셀에 대응하는 평균 신호를 감산하는 것을 특징으로 하는 고체 촬상 장치.

청구항 27

칼라를 센싱하기 위한 픽셀 어레이를 구비하는 고체 촬상 장치의 픽셀들을 배열하는 방법에 있어서,

상기 픽셀들은 적어도 황색(Yellow) 칼라, 녹색(Green) 칼라 및 사이언(Cyan) 칼라를 센싱하는 픽셀들로 이루어지며, 어레이의 수직 방향으로 배치되는 제1 픽셀열에는 동일한 제1 칼라를 센싱하는 픽셀들이 배치되고, 어레이의 수직방향으로 배치되는 제2 픽셀열에는 제2 칼라를 센싱하는 픽셀과 제3 칼라를 센싱하는 픽셀이 교대로 배치되며, 상기 제1 픽셀열과 상기 제2 픽셀열은 어레이의 수평 방향으로 서로 인접하는 것을 특징으로 하는 고체 촬상 장치의 픽셀 배열 방법.

청구항 28

제27항에 있어서,

상기 제1 칼라는 녹색(Green) 칼라이며, 상기 제2 칼라는 황색(Yellow) 칼라이고, 상기 제3 칼라는 사이언(Cyan) 칼라인 것을 특징으로 하는 고체 촬상 장치의 픽셀 배열 방법.

청구항 29

고체 촬상 장치의 신호 처리 방법에 있어서,

황색(Yellow) 칼라신호, 사이언(Cyan) 칼라신호, 상기 사이언(Cyan) 칼라신호에 수평방향으로 인접하는 제1 녹색

색(Green) 칼라신호 및 상기 황색(Yellow) 칼라신호에 수평방향으로 인접하는 제2 녹색(Green) 칼라신호가 픽셀 어레이로부터 출력되는 단계;

상기 신호들 내에 포함되는 크로스 토크(Crosstalk) 성분을 감소시키기 위하여 상기 칼라신호를 선택적으로 연산하는 단계; 및

상기 크로스 토크 성분이 감소된 칼라 신호에 대해 보정 처리를 수행하는 단계를 구비하는 것을 특징으로 하는 고체 촬상 장치의 신호 처리 방법.

청구항 30

제29항에 있어서, 상기 칼라신호를 선택적으로 연산하는 단계는,

상기 황색(Yellow) 칼라신호와 상기 제1 녹색(Green) 칼라신호를 서로 연산하는 제1 과정과, 상기 사이언(Cyan) 칼라신호와 상기 제2 녹색(Green) 칼라신호를 서로 연산하는 제2 과정 및 상기 제1 녹색(Green) 칼라신호와 상기 제2 녹색(Green) 칼라신호를 서로 연산하는 제3 과정들 중 적어도 하나의 과정을 포함하는 것을 특징으로 하는 고체 촬상 장치의 신호 처리 방법.

청구항 31

제30항에 있어서,

상기 제1 과정은, 상기 황색(Yellow) 칼라신호에서 상기 제1 녹색(Green) 칼라신호를 감산하는 과정이고,

상기 제2 과정은, 상기 사이언(Cyan) 칼라신호에서 상기 제2 녹색(Green) 칼라신호를 감산하는 과정이며,

상기 제3 과정은, 상기 제1 녹색(Green) 칼라신호와 상기 제2 녹색(Green) 칼라신호의 평균을 구하는 과정인 것을 특징으로 하는 고체 촬상 장치의 신호 처리 방법.

청구항 32

제29항에 있어서,

상기 픽셀 어레이로부터 출력되는 칼라 신호에 대해 보간 동작을 수행하는 단계를 더 구비하는 것을 특징으로 하는 고체 촬상 장치의 신호 처리 방법.

청구항 33

제32항에 있어서,

상기 보간 처리된 칼라 신호를 이용하여 휘도를 산출하는 단계를 더 구비하며,

상기 휘도 산출 단계는,

상기 보간 처리된 칼라 신호 각각에 대하여 소정의 계수를 승산하는 단계;

상기 승산 처리된 칼라 신호를 입력받아 이들에 대해 가산 연산을 수행하는 단계; 및

상기 가산 연산에 의해 산출된 휘도 신호에 대해서 게인(gain)을 조절하는 단계를 구비하는 것을 특징으로 하는 고체 촬상 장치의 신호 처리 방법.

청구항 34

고체 촬상 장치의 신호 처리 방법에 있어서,

하나 이상의 칼라를 센싱하는 픽셀 어레이로부터 칼라 신호가 출력되는 단계;

상기 출력된 칼라 신호에 대해 보간 동작을 수행하는 단계;

상기 보간 처리된 칼라 신호에 대해서, 동일한 칼라의 신호를 서로 연산함에 기반하여 위색신호를 포함하는 픽셀들의 위치를 검출하고 이에 따른 검출 신호를 발생하는 단계;

상기 검출 신호의 일부 레벨을 변동함으로써 보정신호를 발생하는 단계; 및

상기 보정 신호에 기반하여 상기 보간 처리된 칼라 신호에 대해 가산 연산 및/또는 감산 연산을 수행함으로써

상기 위색신호를 제거하는 단계를 구비하는 것을 특징으로 하는 고체 촬상 장치의 신호 처리 방법.

청구항 35

제34항에 있어서,

상기 픽셀 어레이는, 적어도 황색(Yellow) 칼라, 녹색(Green) 칼라 및 사이언(Cyan) 칼라를 센싱하는 픽셀들을 포함하는 것을 특징으로 하는 고체 촬상 장치의 신호 처리 방법.

청구항 36

제34항에 있어서,

상기 픽셀 어레이는, 수평 방향으로 제1 칼라를 센싱하는 제1 픽셀과 제2 칼라를 센싱하는 제2 픽셀이 교대로 배치되며,

상기 검출 신호를 발생하는 단계는,

제1 칼라 신호들을 서로 감산 연산하여 제1 신호를 발생하는 단계;

제2 칼라 신호들을 서로 감산 연산하여 제2 신호를 발생하는 단계;

상기 제1 신호 및 제2 신호를 서로 합산하여 제3 신호를 발생하는 단계; 및

상기 제3 신호를 상기 어레이의 왼쪽 방향 또는 오른쪽 방향으로 쉬프트(sfift)시켜 상기 검출 신호를 발생하는 단계를 구비하는 것을 특징으로 하는 고체 촬상 장치의 신호 처리 방법.

청구항 37

제36항에 있어서, 상기 위색신호를 제거하는 단계는,

상기 검출된 위치 근방의 픽셀들을 이용하여 평균 칼라 신호를 산출하는 단계; 및

상기 보정신호에 기반하여, 상기 보간 처리된 칼라 신호와 상기 평균 칼라 신호를 서로 합산하거나 감산하는 단계를 구비하는 것을 특징으로 하는 고체 촬상 장치의 신호 처리 방법.

명세서

발명의 상세한 설명

기술분야

<1> 본 발명은 고체 촬상 장치에 관한 것으로서, 더 상세하게는 컬러 필터의 패턴 및 신호 처리 동작을 개선한 고체 촬상 장치, 고체 촬상 장치의 픽셀 배열 방법 및 고체 촬상 장치의 신호 처리 방법에 관한 것이다.

배경기술

<2> 일반적으로, 고체 촬상 장치는 크게 두 가지 방식이 있다. 즉, CIS(CMOS Image Sensor) 형 또는 CCD(Charge-Coupled Device) 형으로 분류된다. CIS 형은 CCD 형에 비해 저전압 동작이 가능하고 소비전력이 작으며, CMOS(complimentary metal-oxide-semiconductor) 공정을 사용하고, 집적화에 유리한 장점으로 인해 CCD 형을 대체하여 현재 많은 분야에서 사용되고 있다.

<3> 고체 촬상 장치는 휴대폰 카메라(mobile camera), 디지털 스틸 카메라(digital still camera) 등에 장착되어, 시야에 전개되는 이미지를 촬상하여 전기적 신호로 변환하여 출력한다. 고체 촬상 장치에 다수의 픽셀이 구비되고, 픽셀 각각에 구비되는 포토 다이오드에 흡수된 빛에 의하여 전하가 생성되며, 이를 전압 또는 전류로 변환함으로써 이미지 신호를 얻게 된다. 상기 과정에서는 이미지의 명암 정보만이 인식되므로, 실제 이미지의 색 정보를 얻기 위해서는 일반적으로 포토 다이오드 상부에 최소 3 종류의 컬러 필터를 배치한다.

<4> 도 1은 일반적인 컬러 필터의 배치를 나타내는 도면이다. 도 1에 도시된 바와 같이 일반적인 컬러 필터는, 3 종류 이상의 컬러 필터가 순차적으로 배열된 패턴을 갖는다. 일례로서 도 1의 (a)에 도시된 바와 같이 적(Red), 녹(Green), 청(Blue)의 세 가지 색을 이용하여 컬러 필터를 배치하거나, (b)에 도시된 바와 같이 황(Yellow), 사이언(Cyan), 마젠타(Magenta) 녹(Green)의 네 가지 색을 이용하여 컬러 필터를 배치한다.

- <5> 고 해상도의 이미지를 얻기 위해, 고체 촬상 장치에 구비되는 픽셀들을 고 집적하면서 픽셀 자체의 사이즈(셀 사이즈)를 감소시키는데, 이에 따라 감도가 저하되는 문제나, 픽셀들 사이에서의 크로스 토크(Crosstalk)가 증가하는 문제가 발생하게 된다. 크로스 토크(Crosstalk)란, 인접한 픽셀의 다른 색 신호가 본래의 색 신호 레벨에 혼입하여 분광특성을 변화시키는 것으로서, SN 저하 및 색 재현에 영향을 미치는 요인이다. 픽셀 사이즈가 소형화될수록 상기와 같은 감도 저하의 문제와 크로스 토크(Crosstalk)에 의한 문제가 심해지게 된다. 종래의 고체 촬상 소자에서는, 이와 같은 감도 저하의 문제나 크로스 토크(Crosstalk)의 문제를 해결하기 위하여, 센싱된 이미지 신호에 게인(Gain)을 부가하거나 컬러 보정회로를 이용하여 보정을 수행하였다. 그러나 상기와 같은 방법을 이용하더라도, 노이즈(Noise)가 증가하거나, 색 재현 향상에 한계가 있었다.
- <6> 한편, 고체 촬상 장치의 각 픽셀에서는 각각에 대응하는 색 신호가 출력되는데, 각각의 픽셀별로 하나의 색 필터가 배치되기 때문에 하나의 픽셀에서 동시에 복수의 색에 대응하는 신호가 출력될 수 없다. 이에 따라 대상 화소에서 출력될 수 없는 색 신호는 보간과정을 통하여 주변의 픽셀을 이용하여 생성되어진다. 이와 같은 보간 과정에서 위색 오차가 발생하게 된다. 종래의 경우에는 상기와 같은 위색 오차를 보정하기 위하여 렌즈와 센서 사이에 광학적 LPF(OLPF)를 삽입하는 방법을 이용하였으나, 이와 같은 방법의 경우 해상도의 저하가 발생하는 문제가 있다.

발명의 내용

해결 하고자하는 과제

- <7> 본 발명은 상기와 같은 문제점을 해결하기 위한 것으로서, 감도 저하나 크로스 토크(Crosstalk)의 문제를 개선할 수 있는 고체 촬상 장치, 고체 촬상 장치의 픽셀 배열 방법 및 고체 촬상 장치의 신호 처리 방법을 제공하는 것을 목적으로 한다.
- <8> 또한 본 발명의 다른 목적은, 컬러 보간 과정에서 발생하는 위색 오차를 효과적으로 감소시킬 수 있는 고체 촬상 장치, 고체 촬상 장치의 픽셀 배열 방법 및 고체 촬상 장치의 신호 처리 방법을 제공하는 것을 목적으로 한다.

과제 해결수단

- <9> 상기와 같은 목적을 달성하기 위하여, 본 발명의 일실시예에 따른 고체 촬상 장치는, 적어도 황색(Yellow) 칼라, 녹색(Green) 칼라 및 사이언(Cyan) 칼라를 센싱하는 픽셀 어레이 및 상기 픽셀 어레이로부터 제공되는 이미지 신호를 입력받아 소정의 연산 동작을 수행하는 칼라 보정부를 구비하며, 상기 픽셀 어레이는, 어레이의 수직방향으로 동일한 제1 칼라를 센싱하는 픽셀들이 배치되는 제1 픽셀열과, 어레이의 수직방향으로 제2 칼라를 센싱하는 픽셀과 제3 칼라를 센싱하는 픽셀이 교대로 배치되는 제2 픽셀열을 구비하는 것을 특징으로 한다.
- <10> 바람직하게는, 상기 제1 픽셀열과 상기 제2 픽셀열은, 어레이의 수평 방향으로 서로 인접하게 배치되는 것을 특징으로 한다.
- <11> 또한 바람직하게는, 상기 어레이의 수평 방향으로 상기 제1 픽셀열과 상기 제2 픽셀열이 교대로 배치되는 것을 특징으로 한다.
- <12> 또한 바람직하게는, 상기 제1 칼라는 녹색(Green) 칼라이며, 상기 제2 칼라는 황색(Yellow) 칼라이고, 상기 제3 칼라는 사이언(Cyan) 칼라인 것을 특징으로 한다.
- <13> 한편, 상기 칼라 보정부는, 상기 입력된 신호들에 포함된 크로스 토크(Crosstalk) 성분을 감소시키기 위한 연산을 수행하는 크로스 토크 보정회로 및 상기 크로스 토크 보정회로로부터 보정된 신호를 입력받아 이를 표준 이미지 신호로 보정하는 색 보정 매트릭스(Matrix) 회로를 구비할 수 있다.
- <14> 또한, 상기 고체 촬상 장치는, 상기 픽셀 어레이 및 상기 칼라 보정부 사이에 배치되며, 상기 픽셀 어레이로부터 칼라 신호를 입력받아 이에 대한 보간(Interpolation) 동작을 수행하는 보간부를 더 구비할 수 있다.
- <15> 또한, 상기 고체 촬상 장치는, 상기 픽셀 어레이로부터 제공되는 칼라 신호를 이용하여 이미지의 휘도 성분을 산출하기 위한 휘도 산출부를 더 구비할 수 있다.
- <16> 또한, 상기 휘도 산출부는, 입력된 칼라 신호에 각각에 대하여 소정의 계수를 승산하기 위한 승산기와, 상기 승산기로부터 승산 처리된 칼라 신호를 입력받아, 이에 대한 가산 동작을 수행하여 휘도신호를 산출하는 가산기

및 상기 가산기로부터 제공된 휘도신호를 입력받아 게인(gain)을 조절하는 게인 조절부를 구비할 수 있다.

- <17> 한편, 상기 고체 촬상 장치는 CMOS 이미지 센서가 적용될 수 있다.
- <18> 한편, 본 발명의 다른 실시예에 따른 고체 촬상장치는, 적어도 황색(Yellow) 칼라, 녹색(Green) 칼라 및 사이언(Cyan) 칼라를 센싱하는 픽셀 어레이 및 상기 픽셀 어레이로부터 제공되는 이미지 신호에 포함된 크로스 토크(Crosstalk) 성분을 감소시키는 칼라 보정부를 구비하며, 상기 픽셀 어레이는, 수직 방향으로 두 개의 픽셀과 수평 방향으로 두 개의 픽셀에 해당하는 크기를 갖는 픽셀 그룹을 복수 개 구비하고, 상기 픽셀 그룹 각각은 제 1 칼라를 센싱하는 두 개의 픽셀과 제2 칼라를 센싱하는 하나의 픽셀 및 제3 칼라를 센싱하는 하나의 픽셀을 포함하며, 상기 제1 칼라를 센싱하는 두 개의 픽셀은 수직 방향으로 인접하게 배치되는 것을 특징으로 한다.
- <19> 한편, 본 발명의 또 다른 실시예에 따른 고체 촬상장치는, 복수의 행 및 복수의 열 방향으로 배치되는 픽셀들을 포함하는 픽셀 어레이와, 상기 픽셀 어레이로부터 제공된 칼라 신호에 대해 보간 동작을 수행하는 보간부 및 상기 보간부로부터 보간 처리된 칼라 신호를 입력받으며, 동일한 칼라의 신호를 서로 연산함에 기반하여 위색신호를 포함하는 픽셀들의 위치를 검출하고 이에 따른 보정신호를 발생하며, 상기 보간 처리된 칼라신호에 대해 상기 보정신호에 기반하여 가산 연산 및/또는 감산 연산을 수행함으로써 상기 위색신호를 제거하는 위색신호 제거부를 구비하는 것을 특징으로 한다.
- <20> 한편, 본 발명의 일실시예에 따른 고체 촬상 장치의 픽셀들을 배열하는 방법에 있어서, 상기 픽셀들은 적어도 황색(Yellow) 칼라, 녹색(Green) 칼라 및 사이언(Cyan) 칼라를 센싱하는 픽셀들로 이루어지며, 픽셀 어레이의 수직 방향으로 배치되는 제1 픽셀열에는 동일한 제1 칼라를 센싱하는 픽셀들이 배치되고, 픽셀 어레이의 수직방향으로 배치되는 제2 픽셀열에는 제2 칼라를 센싱하는 픽셀과 제3 칼라를 센싱하는 픽셀이 교대로 배치되며, 상기 제1 픽셀열과 상기 제2 픽셀열은 픽셀 어레이의 수평 방향으로 서로 인접하는 것을 특징으로 한다.
- <21> 한편, 본 발명의 일실시예에 따른 고체 촬상 장치의 신호 처리 방법은, 황색(Yellow) 칼라신호, 사이언(Cyan) 칼라신호, 상기 사이언(Cyan) 칼라신호에 수평방향으로 인접하는 제1 녹색(Green) 칼라신호 및 상기 황색(Yellow) 칼라신호에 수평방향으로 인접하는 제2 녹색(Green) 칼라신호가 픽셀 어레이로부터 출력되는 단계와, 상기 신호들 내에 포함되는 크로스 토크(Crosstalk) 성분을 감소시키기 위하여 상기 칼라신호를 선택적으로 연산하는 단계 및 상기 크로스 토크 성분이 감소된 칼라 신호에 대해 보정 처리를 수행하는 단계를 구비하는 것을 특징으로 한다.
- <22> 한편, 본 발명의 다른 실시예에 따른 고체 촬상 장치의 신호 처리 방법은, 하나 이상의 칼라를 센싱하는 픽셀 어레이로부터 칼라 신호가 출력되는 단계와, 상기 출력된 칼라 신호에 대해 보간 동작을 수행하는 단계와, 상기 보간 처리된 칼라 신호에 대해서, 동일한 칼라의 신호를 서로 연산함에 기반하여 위색신호를 포함하는 픽셀들의 위치를 검출하고 이에 따른 검출 신호를 발생하는 단계와, 상기 검출 신호의 일부 레벨을 변동함으로써 보정신호를 발생하는 단계 및 상기 보정 신호에 기반하여 상기 보간 처리된 칼라 신호에 대해 가산 연산 및/또는 감산 연산을 수행함으로써 상기 위색신호를 제거하는 단계를 구비하는 것을 특징으로 한다.

효 과

- <23> 상기한 바와 같은 본 발명에 따르면, 고체 촬상 장치에서 주로 문제가 되는 크로스 토크(Crosstalk) 성분 및 위색신호를 효과적으로 제거할 수 있으므로, 고체 촬상 장치의 색 재현성을 향상시킬 수 있는 효과가 있다.

발명의 실시를 위한 구체적인 내용

- <24> 본 발명과 본 발명의 동작상의 이점 및 본 발명의 실시예에 의하여 달성되는 목적을 충분히 이해하기 위해서는 본 발명의 바람직한 실시 예를 예시하는 첨부 도면 및 도면에 기재된 내용을 참조하여야 한다.
- <25> 이하, 첨부한 도면을 참조하여 본 발명의 바람직한 실시 예를 설명함으로써, 본 발명을 상세히 설명한다. 각 도면에 제시된 동일한 참조부호는 동일한 부재를 나타낸다.
- <26> 도 2는 본 발명의 일실시예에 따른 고체 촬상 장치의 일예를 나타내는 블록도이다. 도시된 바와 같이 상기 고체 촬상 장치(100)는, 하나 이상의 픽셀이 배열되는 픽셀 어레이(110)와, 픽셀 어레이(110)에서 출력되는 전기적인 이미지 신호에 대하여 보간(Interpolation)을 수행하는 보간부(120)와, 보간부(120)로부터 출력된 신호에 대하여 크로스 토크(Crosstalk)를 제거하고 상기 이미지 신호를 표준 이미지 신호로 보정하기 위한 칼라 보정부(130)를 구비할 수 있다. 또한 상기 고체 촬상 장치(100)는, 칼라 보정부(130)로부터 입력된 이미지 신호의 적(Red), 녹(Green), 청(Blue)의 비율을 조절하여 이미지의 백색 부분이 표현되도록 하는 백색 밸런스 조정부

(140)와, 백색 밸런스 조정된 이미지 신호에 대한 감마 보정을 수행하는 감마 보정부(150)와, 상기 적(Red), 녹(Green), 청(Blue)의 칼라를 이용하여 색도 성분(Cr, Cb)를 출력하기 위한 칼라 변환부(160)를 구비할 수 있다. 한편, 바람직하게는 상기 고체 촬상 장치(100)는, 별도의 경로를 통하여 이미지의 휘도 성분(Y)을 산출하기 위한 휘도 산출부(170)를 더 구비할 수 있다.

<27> 도 3은 도 2의 고체 촬상 장치에 구비되는 픽셀 어레이의 배열의 일례를 나타내는 도면이다. 도시된 바와 같이 본 발명의 일실시예에 따른 고체 촬상 장치(100)에 구비되는 픽셀 어레이(110)는, 황(Yellow), 사이언(Cyan), 녹(Green)의 세 가지 필터를 갖는 픽셀들로 이루어진다. 상기 종류의 필터는 모두 녹(Green) 성분을 포함하고 있어서 입사광의 휘도 신호 성분을 많이 통과시키므로 감도를 향상시킨다.

<28> 특히 상기 황(Yellow), 사이언(Cyan), 녹(Green)의 세 가지 색의 필터를 이용한 픽셀 구조에 있어서, 본 발명의 일실시예에 따른 픽셀 어레이(110)는, 어레이의 수직 방향으로 배치되는 픽셀열을 복수 개 구비한다. 특히 픽셀 열들 중 제1 픽셀열에는 동일한 제1 칼라를 센싱하는 픽셀들이 배치된다. 또한 픽셀열들 중 제2 픽셀열에는 제2 칼라를 센싱하는 픽셀과 제3 칼라를 센싱하는 픽셀이 교대로 배치된다. 바람직하게는 상기 제1 픽셀열과 제2 픽셀열은 어레이의 수평 방향으로 서로 인접하게 배치된다. 또한 상기 픽셀 어레이(110)의 수평 방향으로 상기 제1 픽셀열과 제2 픽셀열이 교대로 배치된다. 또한 바람직하게는, 제1 칼라를 센싱하는 픽셀은 녹색(Green) 칼라를 센싱하기 위한 픽셀이고, 제2 칼라를 센싱하는 픽셀은 사이언(Cyan) 칼라를 센싱하기 위한 픽셀이며, 제3 칼라를 센싱하는 픽셀은 황색(Yellow) 칼라를 센싱하기 위한 픽셀이다. 이에 따라 상기 픽셀 어레이(110)는, 홀수 번째(또는, 짝수 번째)의 픽셀열에 녹(Green) 필터를 구비하는 픽셀들이 배치되며, 짝수 번째(또는, 홀수 번째)의 픽셀열에는 사이언(Cyan) 필터를 구비하는 픽셀과 황(Yellow) 필터를 구비하는 픽셀이 교대로 배치된다. 즉, 본 발명의 일실시예에 따르면, 스트라이프(Stripe)와 모자이크(Mosaic) 배열 방식을 혼합하여 3 종류의 색 필터를 배치한다.

<29> 상기와 같이 구성되는 본 발명의 일실시예에 따른 고체 촬상 장치(100)의 크로스 토크(Crosstalk)에 의한 영향을 도 4 내지 도 7을 참조하여 설명한다.

<30> 도 4는 도 3의 픽셀들 중 제1 녹(Green) 필터(G1)를 갖는 픽셀이 받는 크로스 토크(Crosstalk) 성분을 나타내는 도면이다. 도 4a에 도시된 바와 같이, 제1 녹(Green) 필터를 갖는 픽셀은 주위의 픽셀들로부터 크로스 토크(Crosstalk) 성분을 받는다. 자세하게는, 수직으로 인접하는 제2 녹(Green) 필터(G2)를 갖는 픽셀들로부터 $G2'' = C2 + C6$ 에 해당하는 크로스 토크(Crosstalk) 성분을 받는다. 또한, 수평으로 인접하는 사이언(Cyan) 필터를 갖는 픽셀들로부터 $Cy'' = C4 + C8$ 에 해당하는 크로스 토크(Crosstalk) 성분을 받는다. 또한, 대각으로 인접하는 황(Yellow) 필터를 갖는 픽셀들로부터 $Ye'' = C1 + C3 + C5 + C7$ 에 해당하는 크로스 토크(Crosstalk) 성분을 받는데, 상기와 같이 대각으로 인접하는 픽셀들로부터의 크로스 토크(Crosstalk) 성분은 그 양이 작기 때문에 무시할 수 있다.

<31> G1, G2 픽셀의 포토 다이오드에서 구할 수 있는 본래의 신호 성분을 각각 G1, G2으로 정의하고, Ye 픽셀의 포토 다이오드에서 구할 수 있는 본래의 신호 성분을 Ye으로 정의하며, Cy 픽셀의 포토 다이오드에서 구할 수 있는 본래의 신호 성분을 Cy으로 정의한다. 이 경우, 크로스 토크(Crosstalk) 성분을 포함하여 G1 픽셀에서 발생하는 신호의 전체값 G1'은 하기하는 수학적 식 1에 해당한다.

수학적 식 1

<32> $G1' = G1 + G2'' + Cy'' = G1 + C2 + C6 + C4 + C8$ (G2''는 수직으로 인접한 G2 픽셀로부터의 크로스 토크 성분, Cy''는 수평으로 인접한 Cy 픽셀로부터의 크로스 토크 성분)

<33> 도 4b는 G1 픽셀과, G1 픽셀에 영향을 주는 크로스 토크 성분을 분광 특성으로 나타낸 것이다. 도시된 바와 같이 장파장이 될수록 크로스 토크 성분은 증가한다. 또한 Cy 픽셀에 의한 크로스 토크 성분은 녹(Green)과 청(Blue) 성분으로 나누어 나타낼 수 있다. 이에 따라 상기 수학적 식 1을 연산하면 하기하는 수학적 식 2가 도출된다.

수학적 식 2

<34> $G1' = G1 + G2'' + Cy'' = G1 + G2'' + (G'' + B'')$

<35> 도 4b에 도시된 바와 같이, 신호 G1' 내에서 차지하는 크로스 토크 성분 B''는 매우 작다. 또한 크로스 토크 성분 G2'' 및 G''는 성분 B''에 비해 장파장인데다가, 본래 G1 신호와 같은 녹(Green) 성분이기 때문에 녹(Green) 신호의 레벨을 크게 하는 효과가 있다.

<36> 도 5는 도 3의 픽셀들 중 제2 녹색(Green) 필터(G2)를 갖는 픽셀이 받는 크로스 토크(Crosstalk) 성분을 나타내는 도면이다. 도 5a에 도시된 바와 같이, 제2 녹색(Green) 필터를 갖는 픽셀은 주위의 픽셀들로부터 크로스 토크(Crosstalk) 성분을 받는다. 자세하게는, 수직으로 인접하는 제1 녹색(Green) 필터(G1)를 갖는 픽셀들로부터 $G1'' = C2 + C6$ 에 해당하는 크로스 토크(Crosstalk) 성분을 받는다. 또한, 수평으로 인접하는 황(Yellow) 필터를 갖는 픽셀들로부터 $Ye'' = C4 + C8$ 에 해당하는 크로스 토크(Crosstalk) 성분을 받는다. 또한, 대각으로 인접하는 사이언(Cyan) 필터를 갖는 픽셀들로부터 $Cy'' = C1 + C3 + C5 + C7$ 에 해당하는 크로스 토크(Crosstalk) 성분을 받는데, 상기와 같이 대각으로 인접하는 픽셀들로부터의 크로스 토크(Crosstalk) 성분은 그 양이 작기 때문에 무시할 수 있다. 상기와 같은 경우, 크로스 토크(Crosstalk) 성분을 포함하여 G2 픽셀에서 발생하는 신호의 전체값 $G2'$ 은 하기하는 수학적 식 3에 해당한다.

수학적 식 3

<37> $G2' = G2 + G1'' + Ye'' = G2 + C2 + C6 + C4 + C8$ ($G1''$ 는 수직으로 인접한 G1 픽셀로부터의 크로스 토크 성분, Ye'' 는 수평으로 인접한 Ye 픽셀로부터의 크로스 토크 성분)

<38> 도 5b는 G2 픽셀과, G2 픽셀에 영향을 주는 크로스 토크 성분을 분광 특성으로 나타낸 것이다. 도시된 바와 같이 장파장이 될수록 크로스 토크 성분은 증가한다. 또한 Ye 픽셀에 의한 크로스 토크 성분은 녹색(Green)과 적(Red) 성분으로 나누어 나타낼 수 있다. 이에 따라 상기 수학적 식 3을 연산하면 하기하는 수학적 식 4가 도출된다.

수학적 식 4

<39> $G2' = G2 + G1'' + Ye'' = G2 + G1'' + (G'' + R'')$

<40> 도 5b에 도시된 바와 같이, 신호 $G2'$ 내에서 차지하는 크로스 토크 성분 R'' 은 장파장이기 때문에 다소 크다. 또한 크로스 토크 성분 $G1''$ 및 G'' 도 비교적 장파장이기 때문에 다소 큰 값을 가지며, $G1''$ 및 G'' 에 의한 크로스 토크 성분은 본래 G2 신호와 같은 녹색(Green) 성분이기 때문에 녹색(Green) 신호의 레벨을 크게 하는 효과가 있다.

<41> 도 6은 도 3의 픽셀들 중 황(Yellow) 필터(Ye)를 갖는 픽셀이 받는 크로스 토크(Crosstalk) 성분을 나타내는 도면이다. 도 6a에 도시된 바와 같이, 황(Yellow) 필터를 갖는 픽셀은 주위의 픽셀들로부터 크로스 토크(Crosstalk) 성분을 받는다. 자세하게는, 수직으로 인접하는 사이언(Cyan) 필터(Cy)를 갖는 픽셀들로부터 $Cy'' = C2 + C6$ 에 해당하는 크로스 토크(Crosstalk) 성분을 받는다. 또한, 수평으로 인접하는 제2 녹색(Green) 필터를 갖는 픽셀들로부터 $G2'' = C4 + C8$ 에 해당하는 크로스 토크(Crosstalk) 성분을 받는다. 또한, 대각으로 인접하는 제1 녹색(Green) 필터를 갖는 픽셀들로부터 $G1'' = C1 + C3 + C5 + C7$ 에 해당하는 크로스 토크(Crosstalk) 성분을 받는데, 상기와 같이 대각으로 인접하는 픽셀들로부터의 크로스 토크(Crosstalk) 성분은 그 양이 작기 때문에 무시할 수 있다. 상기와 같은 경우, 크로스 토크(Crosstalk) 성분을 포함하여 Ye 픽셀에서 발생하는 신호의 전체값 Ye' 은 하기하는 수학적 식 5에 해당한다.

수학적 식 5

<42> $Ye' = Ye + Cy'' + G2'' = Ye + C2 + C6 + C4 + C8$ (Cy'' 는 수직으로 인접한 Cy 픽셀로부터의 크로스 토크 성분, $G2''$ 는 수평으로 인접한 G2 픽셀로부터의 크로스 토크 성분)

<43> 도 6b는 Ye 픽셀과, Ye 픽셀에 영향을 주는 크로스 토크 성분을 분광 특성으로 나타낸 것이다. 도시된 바와 같이 장파장이 될수록 크로스 토크 성분은 증가한다. 또한 Cy 픽셀에 의한 크로스 토크 성분은 녹색(Green)과 청(Blue) 성분으로 나누어 나타낼 수 있다. 이에 따라 상기 수학적 식 5를 연산하면 하기하는 수학적 식 6이 도출된다.

수학적 식 6

<44> $Ye' = Ye + Cy'' + G2'' = Ye + (G'' + B'') + G2''$

<45> 도 6b에 도시된 바와 같이, 신호 Ye' 내에서 차지하는 크로스 토크 성분 B'' 은 단파장이기 때문에 작은 값을 갖는다. 또한 크로스 토크 성분 $G2''$ 및 G'' 는 비교적 장파장이기 때문에 다소 큰 값을 가지며, $G2''$ 및 G'' 에 의한 크로스 토크 성분은 녹색(Green) 성분이기 때문에, Ye 픽셀로부터 발생하는 녹색(Green) 신호의 레벨을 크게 하는 효과가 있다.

<46> 도 7은 도 3의 픽셀들 중 사이언(Cyan) 필터(Cy)를 갖는 픽셀이 받는 크로스 토크(Crosstalk) 성분을 나타내는 도면이다. 도 7a에 도시된 바와 같이, 사이언(Cyan) 필터를 갖는 픽셀은 주위의 픽셀들로부터 크로스 토크

(Crosstalk) 성분을 받는다. 자세하게는, 수직으로 인접하는 황(Yellow) 필터(Ye)를 갖는 픽셀들로부터 $Ye'' = C2 + C6$ 에 해당하는 크로스 토크(Crosstalk) 성분을 받는다. 또한, 수평으로 인접하는 제1 녹색(Green) 필터를 갖는 픽셀들로부터 $G1'' = C4 + C8$ 에 해당하는 크로스 토크(Crosstalk) 성분을 받는다. 또한, 대각으로 인접하는 제2 녹색(Green) 필터 필터를 갖는 픽셀들로부터 $G2'' = C1 + C3 + C5 + C7$ 에 해당하는 크로스 토크(Crosstalk) 성분을 받는데, 상기와 같이 대각으로 인접하는 픽셀들로부터의 크로스 토크(Crosstalk) 성분은 그 양이 작기 때문에 무시할 수 있다. 상기와 같은 경우, 크로스 토크(Crosstalk) 성분을 포함하여 Cy 픽셀에서 발생하는 신호의 전체값 Cy' 은 하기하는 수학적 식 7에 해당한다.

수학적 식 7

- <47> $Cy' = Cy + Ye'' + G1'' = Cy + C2 + C6 + C4 + C8$ (Ye'' 는 수직으로 인접한 Ye 픽셀로부터의 크로스 토크 성분, $G1''$ 는 수평으로 인접한 G1 픽셀로부터의 크로스 토크 성분)
- <48> 도 7b는 Cy 픽셀과, Cy 픽셀에 영향을 주는 크로스 토크 성분을 분광 특성으로 나타낸 것이다. 도시된 바와 같이 장과장이 될수록 크로스 토크 성분은 증가한다. 또한 Ye 픽셀에 의한 크로스 토크 성분은 녹색(Green)과 적(Red) 성분으로 나누어 나타낼 수 있다. 이에 따라 상기 수학적 식 7을 연산하면 하기하는 수학적 식 8이 도출된다.

수학적 식 8

- <49> $Cy' = Cy + Ye'' + G1'' = Cy + (G'' + R'') + G1''$
- <50> 도 7b에 도시된 바와 같이, 신호 Cy' 내에서 차지하는 크로스 토크 성분 R'' 은 장과장이기 때문에 다소 큰 값을 갖는다. 또한 크로스 토크 성분 $G1''$ 및 G'' 또한 비교적 장과장이기 때문에 다소 큰 값을 갖는다. 또한 $G1''$ 및 G'' 에 의한 크로스 토크 성분은 녹색(Green) 성분이기 때문에, Cy 픽셀로부터 발생하는 녹색(Green) 신호의 레벨을 크게 하는 효과가 있다.
- <51> 상술한 바와 같이 픽셀 어레이(110)로부터 출력되는 이미지 신호에 대하여 보간과정이라든지 색 보정 과정을 수행하여 적(Red), 녹색(Green), 청(Blue)의 신호를 구하는 동작과, 이와 동시에 크로스 토크도 제거하는 동작을 설명하면 다음과 같다.
- <52> 도 8은 컬러 보정 동작을 설명하기 위한 고체 촬상 장치를 나타내는 회로도이다. 도시된 바와 같이 픽셀 어레이(110)에서 감지한 이미지 신호(일례로서, 크로스 토크 성분을 포함하는 신호, Cy' , Ye' , $G1'$, $G2'$)가 보간부(120)로 제공된다. 보간부(120)는 수신된 각 픽셀의 이미지 신호에 대하여 보간(Interpolation) 동작을 수행한다.
- <53> 보간(Interpolation)된 픽셀 신호들(Cy' , Ye' , $G1'$, $G2'$)은 칼라 보정부(130)로 제공된다. 바람직하게는 칼라 보정부(130)는, 상기 픽셀 신호들(Cy' , Ye' , $G1'$, $G2'$)에 포함되는 크로스 토크를 제거하기 위한 크로스 토크 보정회로(131)와, 크로스 토크 제거된 이미지 신호를 표준 이미지 신호로 보정하기 위한 색 보정 매트릭스 회로(132)를 구비할 수 있다.
- <54> 보간(Interpolation)된 픽셀 신호들(Cy' , Ye' , $G1'$, $G2'$)은 크로스 토크 보정회로(131)로 제공되어, 다음과 같은 수학적 식 9의 연산과정을 거쳐 출력된다.

수학적 식 9

- <55> $R = Ye' - G1'$,
- <56> $G = (G1' + G2')/2$,
- <57> $B = Cy' - G2'$
- <58> 도 8의 크로스 토크 보정회로(131)에 도시된 바와 같이, 적(Red) 신호를 구하기 위하여 Ye 픽셀로부터의 신호 성분(Ye')에서 G1 픽셀로부터의 신호 성분($G1'$)을 감산한다. 상기 감산 연산에 의하여, Ye' 성분에 존재하였던 크로스 토크 성분 Cy'' 및 $G2''$ 와, $G1'$ 성분에 존재하였던 크로스 토크 성분 Cy'' 및 $G2''$ 가 서로 상쇄된다. 동일한 색 필터에 의해 발생하는 크로스 토크 성분은, 상기 색 필터가 수평으로 인접하는 경우에서와 수직으로 인접하는 경우에서 그 값이 서로 거의 동일하기 때문이다. 따라서, 상기 연산을 통하여 적(Red) 신호를 구하는 것과 동시에, 크로스 토크에 의한 성분을 제거할 수 있게 된다.
- <59> 한편, 청(Blue) 신호를 구하기 위하여 Cy 픽셀로부터의 신호 성분(Cy')에서 G2 픽셀로부터의 신호 성분($G2'$)을

감산한다. 상기 감산 연산에 의하여, Cy' 성분에 존재하였던 크로스 토크 성분 Ye" 및 G1"과, G2' 성분에 존재하였던 크로스 토크 성분 Ye" 및 G1" 가 서로 상쇄된다. 따라서, 상기 연산을 통하여 청(Blue) 신호를 구하는 것과 동시에, 크로스 토크에 의한 성분을 제거할 수 있게 된다.

- <60> 한편, 녹(Green) 신호를 구하기 위하여, G1 픽셀로부터의 신호 성분(G1')와 G2 픽셀로부터의 신호 성분(G2')의 평균을 구한다. 상기 평균 연산을 통하여 녹(Green) 신호를 구함과 동시에 크로스 토크 성분을 줄일 수 있다.
- <61> 상기 신호 성분(G1')와 신호 성분(G2')의 평균($G = (G1' + G2')/2$)은 아래의 수학적식 10과 같이 나타난다. 여기서 $G1 = G2 = G$ 인 것으로 가정하고, $G1'' = G2'' = G''$ 인 것으로 가정한다.

수학적식 10

<62>
$$G = (G1' + G2')/2 = \{G1 + G2'' + (G'' + B'') + G2 + G1'' + (G'' + R'')\}/2 = \{2G + 4G'' + (R'' + B'')\}/2 = (G + 2G'') + (R'' + B'')/2$$

<63> 상기한 바와 같이 구해진 녹(Green) 신호는, 적(Red) 성분 및 청(Blue) 성분의 크로스 토크 성분을 다소 포함하고 있으나, 녹(Green) 성분에 비해 비교적 큰 폭으로 감소된다.

<64> 따라서, 본 발명의 실시예에 따른 고체 촬상 장치(100)에서는, 적(Red), 녹(Green), 청(Blue) 신호를 구하기 위한 연산을 통하여 크로스 토크 성분을 동시에 제거할 수 있다. 또한, 1 값보다 매우 큰 계수를 갖는 매트릭스(Matrix) 회로를 이용하여 크로스 토크 성분을 보정하였던 종래의 경우에 비하여 노이즈(Noise)를 큰 폭으로 감소시킬 수 있다.

<65> 도 9는 크로스 토크가 제거되는 동작을 도식적으로 나타낸 그래프이다. 도시된 바와 같이 도 9a에서는, 적(Red) 신호를 구하기 위한 연산 과정을 거치는 경우 크로스 토크 성분이 상쇄되어 제거되는 것이 도시된다. 또한 도 9b에서는, 청(Blue) 신호를 구하기 위한 연산 과정을 거치는 경우 크로스 토크 성분이 상쇄되어 제거되는 것이 도시된다. 또한 도 9c에서는, 녹(Green) 신호를 구하기 위한 연산 과정을 거치는 경우 크로스 토크 성분이 크게 감소되는 것이 도시된다.

<66> 상술한 바와 같은 본 발명의 실시예에 따른 고체 촬상 장치(100)의 경우, 화소 어레이(110)에 배치되는 필터의 종류를 황(Yellow), 사이언(Cyan) 및 녹(Green)을 이용하므로, 적(Red), 녹(Green), 청(Blue) 필터에 비하여 입사광을 많이 통과시키며, 또한 휘도 신호의 신호 대 잡음비(SNR)를 향상시킬 수 있다. 또한 황(Yellow), 사이언(Cyan) 및 녹(Green) 픽셀로부터 모두 녹(Green) 신호가 발생되므로, 녹(Green) 신호는 전혀 공간 변조를 받지 않으므로 해상도를 높일 수 있는 장점이 있다.

<67> 도 10은 휘도 신호 산출동작을 설명하기 위한 고체 촬상 장치를 나타내는 블록도이다. 도 10에 도시된 여러 구성요소들 중 앞서 언급되었던 구성요소와 동일한 것에 대해서는, 그 동작 또한 동일하므로 이에 대한 자세한 설명은 생략한다.

<68> 도시된 바와 같이, 픽셀 어레이(110)로부터 발생한 각 픽셀의 이미지 신호(Ye, G1, G2, Cy)는 보간부(120)로 제공되며, 보간부(120)는 수신된 이미지 신호에 대하여 보간(Interpolation)을 수행한다. 보간 수행된 이미지 신호(Ye, G1, G2, Cy)는 휘도 산출부(170)로 제공된다. 앞서 언급하였던 바와 같이 픽셀 어레이(110) 및 보간부(120)에서 출력되는 이미지 신호(Ye, G1, G2, Cy)는 크로스 토크 성분을 포함하는 신호이다.

<69> 휘도 산출부(170)는, 승산부(171)와, 가산기(172)와, 게인(gain) 조절부(173) 및 감마 보정부(174)를 구비할 수 있다. 보간부(120)에서 출력되는 이미지 신호(Ye, G1, G2, Cy)는 승산부(171)로 제공되며, 승산부(171)에서 소정의 승산 연산이 수행된다. 일례로서 Ye 신호는 계수 a와 승산되어 가산기(172)로 제공되고, G1 신호는 계수 b와 승산되어 가산기(172)로 제공되며, G2 신호는 계수 c와 승산되어 가산기(172)로 제공되고, Cy 신호는 계수 d와 승산되어 가산기(172)로 제공된다.

<70> 상기 계수들(a,b,c,d)은 임의적인 값으로 설정될 수 있으나, 바람직하게는 휘도 신호(Y)가 $Y = 0.26R + 0.63G + 0.11B$ 의 값으로 구해지도록 $a : b : c : d = 1.0 : 0.5 : 0.5 : 0.4$ 값이 되도록 설정한다. 계수들(a,b,c,d)의 비율을 상기와 같이 설정되고, 가산기(172)에서 각 신호들에 대해 가산 연산을 수행함으로써 상기와 같은 휘도 신호(Y)가 구해질 수 있다. 앞서 언급된 계수들(a,b,c,d)의 비율은 다소 다르게 조절되더라도 본 발명의 목적은 무방하게 달성될 수 있다.

<71> 가산기(172)에서 구해진 휘도 신호(Y)는 게인(gain) 조절부(173)로 입력된다. 게인(gain) 조절부(173)는 입력된 휘도 신호(Y)의 게인(gain)을 조절한다. 보간부(120)에서 출력되는 이미지 신호(Ye, G1, G2, Cy)는, 소정의 칼

라 보정부(130) 및 백색 밸런스 조정부(140)를 거쳐 감마 보정부(150)로 제공되는데, 상기 보정을 거치는 동안 신호의 레벨이 변동하게 된다. 이에 따라서, 별도의 경로를 통해 구해지는 휘도 신호(Y)의 레벨도 조절할 필요가 있다. 바람직하게는, 게인(gain) 조절부(173)는, 상기 칼라 보정부(130) 및 백색 밸런스 조정부(140)에 의해 변동된 레벨에 해당하는 값 만큼 휘도 신호(Y)의 레벨을 조절한다. 즉, 백색 밸런스 조정부(140)를 통과한 R,G,B 신호의 레벨과 게인(gain) 조절부(173)를 통해 출력된 휘도 신호(Y)의 레벨이 같아지도록 한다.

- <72> 게인(gain) 조절부(173)를 통해 출력된 휘도 신호(Y)는 휘도 산출부(170)에 구비되는 감마 보정부(174)로 입력되어 소정의 감마 처리가 수행된다. 상기 감마 처리 동작은, 백색 밸런스 조정부(140)와 연결되는 감마 보정부(150)의 동작과 동일한 특성을 갖도록 한다. 상기 감마 보정부(174)에서 출력되는 감마 조절된 휘도 신호(Y)를 최종 휘도 신호(Y)로서 사용한다. 한편, 도시되지는 않았으나, 상기 휘도 산출부(170)의 감마 보정부(174)와 백색 밸런스 조정부(140)에 연결되는 감마 보정부(150)는 하나의 감마 보정 블록으로 구현될 수 있으며, 상기 감마 보정 블록에서 휘도 신호(Y) 및 R,G,B 신호를 동시에 처리하도록 회로 구성의 일부 변형이 가능하다.
- <73> 한편, 칼라 변환부(160)는 감마 보정부(150)에서 제공된 R,G,B 신호를 색도 신호(Cr, Cb)로 변환한다. 한편, 상술한 바와 같이 휘도 신호(Y)는 휘도 산출부(170)에서 제공되므로, 칼라 변환부(160)는 별도의 휘도 신호(Y)를 발생할 필요가 없다. 상술한 과정을 통해 구해진 휘도 신호(Y) 및 색도 신호(Cr, Cb)는 외부로 제공되어진다. 만약 외부로 R,G,B 신호를 출력하는 경우에는, RGB 변환부(180)이 상기 구해진 휘도 신호(Y) 및 색도 신호(Cr, Cb)를 입력받아, 이를 변환하여 R, G, B 신호를 발생한다. 상기와 같은 동작에 따라, 휘도 신호(Y)의 신호 대 잡음비(SNR)를 개선할 수 있으며, RGB 필터를 사용한 경우에 비해 감도를 향상시킬 수 있다.
- <74> 도 11은 본 발명의 다른 실시예에 따른 고체 촬상 장치의 동작을 설명하기 위한 픽셀 어레이를 나타내는 도면이다. 도시된 바와 같이 픽셀 어레이(210)는, 황색(Yellow) 칼라, 녹색(Green) 칼라 및 사이언(Cyan) 칼라를 센싱하는 픽셀들로 이루어진다. 도 11에는 픽셀 어레이(210)의 일부로서 5*5 구조의 픽셀들만을 도시하였다. 일례로서 Ye33은, 상기 5*5 구조의 픽셀들에서 3행 3열에 배치되는 황색(Yellow) 칼라를 센싱하는 픽셀을 나타낸다.
- <75> 도 12는 도 11의 픽셀 어레이에서 발생된 위색 신호를 나타내는 도면이다. 특히 픽셀 어레이(210)의 상기 5*5 구조의 픽셀들에서, 수평 방향으로 세 번째 픽셀까지는 백색에 해당하는 입사광이 입력되고, 수평 방향으로 네 번째 및 다섯 번째 픽셀로는 검정에 해당하는 입사광이 입력된다고 가정하자.
- <76> 일반적으로 어느 하나의 픽셀에서는 하나의 칼라만을 센싱하므로, 상기 픽셀에서 센싱하지 못하는 칼라 신호는 주변의 픽셀을 이용하여 보간 동작을 통하여 생성한다. 그러나 상기 보간 동작에 의하여 위색 오차가 발생할 수 있다.
- <77> 상기 5*5 구조의 픽셀들에서 세 번째 행에 배치되는 픽셀들을 위주로 설명한다. 먼저, 픽셀 Ye33은 Ye 필터를 구비하므로, 픽셀 Ye33으로부터 발생하는 황색(Yellow) 칼라 신호 ye33은 하이 레벨을 갖는다. 반면에 녹색(Green) 신호는 Ye33 픽셀로부터 발생되지 않으므로 보간 동작을 통하여 산출하게 된다. Ye33에 수평으로 인접한 픽셀 G32 와 G34를 이용하여 보간을 수행하면, 픽셀 Ye33 위치에서의 녹색(Green) 신호 g33은 $(G32 + G34)/2$ 값에 해당한다. 따라서 상기 신호 g33의 레벨은 중간 레벨을 갖는다. 즉, 픽셀 Ye33은 백색에 해당하는 입사광이 입력되었으므로 상기 신호 g33의 레벨이 하이 레벨이 되어야 하나, 빗금친 부분에 해당하는 만큼 위색 신호가 발생한다.
- <78> 한편, 픽셀 Ye33으로부터는 사이언(Cyan) 신호가 발생되지 않으므로, 픽셀 Ye33에 수직으로 인접한 픽셀 Cy23, Cy43을 이용하여 보간 동작을 수행한다. 이에 따른 픽셀 Ye33 위치에서의 사이언(Cyan) 신호 cy33은 $(Cy23 + Cy43)/2$ 에 해당하며, 상기 cy33의 레벨은 하이 레벨을 갖는다.
- <79> 한편, 픽셀 G34는 G 필터를 구비하므로, 픽셀 G34으로부터 발생하는 녹색(Green) 칼라 신호 g34은 로우 레벨을 갖는다. 반면에 황색(Yellow) 신호는 G34 픽셀로부터 발생되지 않으므로 보간 동작을 통하여 산출하게 된다. G34에 수평으로 인접한 픽셀 Ye33 와 Ye35를 이용하여 보간을 수행하면, 픽셀 G34 위치에서의 황색(Yellow) 신호 ye34는 $(Ye33 + Ye35)/2$ 값에 해당한다. 따라서 상기 신호 ye34의 레벨은 중간 레벨을 갖는다. 즉, 빗금친 부분에 해당하는 만큼 위색 신호가 발생한다.
- <80> 한편, 픽셀 G34으로부터는 사이언(Cyan) 신호가 발생되지 않으므로, 픽셀 G34에 대각으로 인접한 픽셀 Cy23, Cy25, Cy43, Cy45을 이용하여 보간 동작을 수행한다. 이에 따른 픽셀 G34 위치에서의 사이언(Cyan) 신호 cy34은 $(Cy23 + Cy25 + Cy43 + Cy45)/4$ 에 해당하며, 상기 cy34의 레벨은 중간 레벨을 갖는다. 즉, 빗금친 부분에 해당하는 만큼 위색 신호가 발생한다.
- <81> 한편, 상기와 같이 위색 신호가 발생한 사이언(Cyan), 녹색(Green) 및 황색(Yellow) 신호를 이용하여 R, G, B 신

호를 생성하면, 생성된 R, G, B 신호에 빗금친 부분과 같이 오차가 발생한다. 따라서 사이언(Cyan), 녹색(Green) 및 황색(Yellow) 신호에 발생하는 상기 위색신호를 제거하기 위해서는 화살표 방향과 같은 신호 레벨의 조정이 필요하다.

- <82> 도 13은 본 발명의 다른 실시예에 따른 고체 촬상 장치를 나타내는 블록도이다. 도시된 바와 같이 상기 고체 촬상 장치(200)는, 픽셀 어레이(210), 보간부(220), 칼라 보정부(230) 및 위색신호 제거부(240)를 구비한다. 또한 상기 위색신호 제거부(240)는, 보정신호 발생부(241) 및 오차 보정부(242)를 구비할 수 있다. 바람직하게는 상기 보정신호 발생부(241)는 보간부(220)로부터 칼라 신호를 입력받아 이를 이용하여 위색 신호가 발생하는 픽셀의 위치를 검출한다. 또한 바람직하게는, 상기 오차 보정부(242)는 보간부(220)와 칼라 보정부(230) 사이에 연결되며, 보정신호 발생부(241)로부터 제공된 신호를 이용하여 위색 신호를 제거한다.
- <83> 도 13에 도시된 바와 같은 고체 촬상 장치(200)가 위색 신호를 제거하는 동작을 도 14 및 도 15를 이용하여 상세하게 설명한다.
- <84> 도 14는 위색신호가 발생한 픽셀의 위치를 검출하고 보정 신호를 발생하는 과정을 나타내는 도면이다. 일례로서, 앞서 언급하였던 도 11 및 도 12의 경우에는 수평 방향으로 세 번째 픽셀 및 네 번째 픽셀에서 위색 신호가 발생하는 예를 설명하였다. 도 14 및 도 15에서는 상기와 같은 예에서 픽셀의 위치를 검출하는 경우를 나타내며, 설명의 편의를 위해 세 번째 행에 위치한 픽셀들을 중심으로 설명한다.
- <85> 보정신호 발생부(241)는, 픽셀 어레이(210)로부터 제공된 칼라 신호(일례로서, 보간 처리된 칼라 신호)를 입력받으며, 이로부터 위색신호가 발생한 픽셀의 위치를 검출하고 또한 보정 신호를 발생한다. 먼저, 위색신호가 발생한 픽셀의 위치를 검출하기 위하여, 동일 색의 필터를 구비하는 픽셀들 사이의 신호를 감산한다. 일례로서, 녹색(Green)을 센싱하는 두 번째 열의 픽셀(G32)과 네 번째 열의 픽셀(G34)의 신호에 대해 감산 연산을 수행한다. 또한 네 번째 열의 픽셀(G34)과 여섯 번째 열의 픽셀(미도시)의 신호에 대해 감산 연산을 수행한다. 상기와 같은 감산 동작이 픽셀 어레이(210)의 전체 열에 걸쳐 수행된다.
- <86> 한편, 황색(Yellow) 칼라를 센싱하는 픽셀들 사이에서도 상기와 같은 감산 연산이 수행된다. 일례로서 첫 번째 열의 픽셀(Y31)과 세 번째 열의 픽셀(Y33)의 신호에 대해 감산 연산을 수행한다. 또한 세 번째 열의 픽셀(Y33)과 다섯 번째 열의 픽셀(Y35)의 신호에 대해 감산 연산을 수행한다. 도 14의 (a)에서와 같이, 수평 방향으로 세 번째 픽셀까지는 백색에 해당하는 입사광이 입력되고, 수평 방향으로 네 번째 픽셀 이후로는 검정에 해당하는 입사광이 입력된다고 가정하였으므로, 도 14의 (b) 내지 (d)와 같은 감산 연산의 결과 신호가 나타난다. 도 14에서는 녹색(Green) 픽셀들 사이의 연산 결과를 (b)와 (d)에 각각 따로 도시하였으나, 상기 연산 결과는 하나의 신호로서 발생할 수 있다.
- <87> 상기 연산 결과 후, 녹색(Green) 픽셀들 사이의 연산 결과와 황색(Yellow) 픽셀들 사이의 연산 결과를 서로 합산하여 (e)에 도시된 바와 같은 신호를 발생시킨다. 동일 칼라 픽셀들간에 감산 연산을 함에 있어서, 왼쪽에 배치되는 픽셀의 신호에서 오른쪽에 배치되는 픽셀의 신호를 감산하였다면, 상기 (e)와 같은 합산 결과의 신호를 1 픽셀에 해당하는 만큼 오른쪽으로 쉬프트시키고, 이에 따라 (f)와 같은 위치 검출신호를 발생시킨다. 도시되지는 않았으나, 만약 오른쪽에 배치되는 픽셀 신호에서 왼쪽에 배치되는 픽셀의 신호를 감산하였다면, 상기 (e)와 같은 합산 결과의 신호를 왼쪽으로 1 픽셀에 해당하는 만큼 쉬프트시킨다.
- <88> 도 14의 (f)에 도시된 바와 같이, 상기와 같은 과정을 통하여 위색 신호가 발생한 두 개의 픽셀이 검출될 수 있다. 이후, 상기 검출신호에서, 검출된 두 개의 픽셀의 위치 중 어느 하나에 대응하는 신호의 레벨을 반전시킨다. 바람직하게는, 상기 검출된 두 개의 픽셀 중 오른쪽에 위치하는 픽셀에 대응하는 신호의 레벨을 반전시켜 (g)와 같이 도시되는 보정신호를 발생시킨다. 도시되지는 않았으나, 만약 상기 감산 연산 수행시 오른쪽 쪽에 배치되는 픽셀 신호에서 왼쪽에 배치되는 픽셀의 신호를 감산하였다면, 상기 검출된 두 개의 픽셀 중 왼쪽에 위치하는 픽셀에 대응하는 신호의 레벨을 반전시킬 수 있다.
- <89> 상기와 같은 과정을 통해 발생된 위치 검출신호 및/또는 보정신호는 도 13에 도시된 오차 보정부(242)로 제공될 수 있다. 오차 보정부(242)에서 수행되는 오차 보정동작을 도 15를 참조하여 설명한다.
- <90> 도 15는 칼라 신호에 발생하는 위색 신호를 제거하는 과정을 나타내는 도면이다. 도 15에서 (a)는 입사광의 특성, (b)는 위치 검출신호를 나타내며, (c)는 보정신호 발생부(241)에서 발생된 보정신호의 일례를 나타낸다.
- <91> 도 15에 도시된 바와 같이, 오차 보정부(242)는 픽셀 신호 및 보정신호를 입력받아, 위색 신호를 제거하기 위한 소정의 보정 동작을 수행한다. 이를 위하여, 픽셀 신호 및 보정신호를 입력받아, 이에 기반하여 위색신호가 발생한 픽셀(오차 픽셀)의 평균 G 신호, 평균 Ye 신호 및 평균 Cy 신호를 산출한다. 상세하게는, 입력된 픽셀 신

호 및 보정신호에 기반하여, 오차 픽셀 근방의 녹색(Green) 신호(일예로서, (d)에 도시된 바와 같은)로부터 (e)에 도시된 바와 같은 평균 G 신호를 산출한다. 마찬가지로, 오차 픽셀 근방의 황색(Yellow) 신호(일예로서, (f)에 도시된 바와 같은)로부터 (g)에 도시된 바와 같은 평균 Ye 신호를 산출한다. 또한 오차 픽셀 근방의 사이언(Cyan) 신호로부터 평균 Cy 신호(미도시)를 산출한다.

- <92> 오차 보정부(242)는, 보간부(220)로부터 제공된 보간된 칼라신호(녹색(Green), 황색(Yellow) 및 사이언(Cyan) 신호) 각각과 상기 산출된 평균 G 신호, 평균 Ye 신호 및 평균 Cy 신호를 각각 연산한다. 자세하게는, 보정신호가 하이 레벨인 경우((+) 신호인 경우)에는, 칼라신호와 평균 신호를 서로 가산한다. 한편, 보정신호가 로우 레벨인 경우((-) 신호인 경우)에는, 칼라신호에서 평균 신호를 감산한다. 도시된 바와 같이, Ye33 픽셀에 대응하는 보정 신호는 하이 레벨을 가지므로, Ye33 픽셀에 대응하는 녹색(Green) 신호(보간에 의해 산출된 신호)와 평균 G 신호를 합산한다. 상기 합산 결과에 따라 (h)에 도시된 바와 같은 위색신호가 제거된 녹색(Green) 신호가 발생된다.
- <93> 한편, G34 픽셀에 대응하는 보정 신호는 로우 레벨을 가지므로, G34 픽셀에 대응하는 황색(Yellow) 신호(보간에 의해 산출된 신호)에서 평균 Ye 신호를 감산한다. 상기 감산 결과에 따라, (i)에 도시된 바와 같은 위색신호가 제거된 황색(Yellow) 신호가 발생된다. 한편, 도시되지는 않았으나, G34 픽셀에 대응하는 사이언(Cyan) 신호(보간에 의해 산출된 신호)에서 평균 Cy 신호를 감산하는 동작 또한 수행되며, 상기 감산 결과에 따라 위색신호가 제거된 사이언(Cyan) 신호가 발생된다. 칼라 보정부(230)는 위색 오차가 제거된 칼라 신호(녹색(Green), 황색(Yellow) 및 사이언(Cyan) 신호)를 입력받아 이를 RGB 신호로 변환한다. 상기 변환을 위하여, 칼라 보정부(230)는 $R = Ye - G$, $G = G$, $B = Cy - G$ 의 연산을 수행할 수 있다.
- <94> 한편, 상기 도 13에 도시된 도면에서는, 칼라 보정부(230), 보정신호 발생부(241) 및 오차 보정부(242)가 서로 다른 블록으로 도시되었으나, 본 발명의 실시예가 이에 국한되는 것은 아니다. 센싱된 칼라 신호에 대해 소정의 연산 동작을 처리하기 위해서, 상기 칼라 보정부(230), 보정신호 발생부(241) 및 오차 보정부(242)는 상술하였던 바와 같은 연산 과정을 모두 반영하는 하나의 블록으로도 구현될 수 있다. 또한 상술하였던 평균 G 신호, 평균 Ye 신호 및 평균 Cy 신호는 보정신호에 기반하여 산출되는 것으로 서술되었으나, 위치 검출신호를 기반으로 하여 산출되어도 무방하다.
- <95> 도 16은 본 발명의 일실시예에 따른 고체 촬상 장치의 신호 처리 방법을 나타내는 플로우 차트이다. 특히 상기 신호 처리 방법은, 최종 출력되는 칼라 신호의 크로스 토크(Crosstalk) 성분을 감소시키며, 또한 칼라 신호의 일반적인 신호 처리 경로와는 별도의 경로를 통해 휘도 신호를 산출하는 방법을 나타낸다. 도 16에 도시된 방법과 관련하여서는, 이에 대응하는 장치에 관한 설명을 통하여 상술하였으므로 자세한 설명은 생략한다.
- <96> 도 16에 도시된 바와 같이 고체 촬상 장치에 구비되는 픽셀 어레이로부터 칼라 신호가 출력된다(S11). 특히 본 발명의 일실시예에 따르면, 상기 픽셀 어레이는 황색(Yellow) 칼라, 녹색(Green) 칼라 및 사이언(Cyan) 칼라를 센싱하기 위한 픽셀을 구비한다. 바람직하게는, 복수의 열과 복수의 행으로 이루어지는 상기 픽셀 어레이에서, 어느 하나의 열(픽셀열)에는 녹색(Green) 칼라를 센싱하는 픽셀들이 배치되며, 상기 열과 인접한 다른 열에는 황색(Yellow) 칼라를 센싱하는 픽셀과 사이언(Cyan) 칼라를 센싱하는 픽셀이 교대로 배치된다. 상기 사이언(Cyan) 칼라신호에 수평방향으로 인접하는 녹색(Green) 칼라신호를 제1 녹색(Green) 칼라신호(G1)라 하고, 상기 황색(Yellow) 칼라신호에 수평방향으로 인접하는 녹색(Green) 칼라신호를 제2 녹색(Green) 칼라신호(G2)로 정의한다.
- <97> 상기와 같이 출력된 칼라 신호들(Ye, G1, G2, Cy)에 대해 보간 처리를 수행한다(S12). 또한, 상기 보간 처리된 칼라 신호들(Ye, G1, G2, Cy)에는 크로스 토크(Crosstalk) 성분이 포함될 수 있으므로, 상기 크로스 토크(Crosstalk) 성분을 감소시키기 위한 연산 동작이 수행된다(S13). 바람직하게는 상기 연산 동작은, $R = Ye - G1$, $G = (G1 + G2)/2$ 및 $B = Cy - G2$ 으로 이루어진다. 상기와 같은 연산 동작에 의하여, 황색(Yellow) 칼라, 녹색(Green) 칼라 및 사이언(Cyan) 칼라를 RGB 신호로 변환함과 동시에 상기 크로스 토크(Crosstalk) 성분을 감소시킬 수 있다. 일예로서, 적(Red) 신호를 구하기 위하여 Ye 픽셀의 신호에서 G1 픽셀의 신호를 감산하는데, Ye 픽셀의 신호에 포함된 크로스 토크 성분과 G1 픽셀의 신호에 포함된 크로스 토크 성분이 서로 동일하므로 상기 감산 연산에 의해서 크로스 토크 성분을 제거할 수 있다.
- <98> 상기와 같은 연산을 통하여 크로스 토크 성분이 감소된 RGB 신호가 발생되면, 이에 대하여 일반적인 신호 처리 절차가 진행된다. 일예로서 상기 RGB 신호에 대하여 백색 밸런스를 조절할 수 있으며(S14), 또한 상기 RGB 신호에 대하여 감마 보정을 수행할 수 있다(S15).

- <99> 한편, 본 발명의 고체 촬상 장치는, 칼라 신호의 일반적인 신호 처리 경로와는 별도의 경로는 통해 휘도 신호를 산출할 수 있으며, 바람직하게는 보간 처리된 칼라 신호를 이용하여 이에 대해 소정의 연산과정을 수행함으로써 상기 휘도 신호를 산출할 수 있다.
 - <100> 보간 처리된 칼라 신호에 대해 소정의 계수를 승산하는 단계가 수행된다(S16). 상세하게는 칼라 신호들(Ye, G1, G2, Cy)에 대해 서로 다른 비율의 계수를 승산할 수 있다. 일례로서, Ye 신호는 계수 a와 승산되고, G1 신호는 계수 b와 승산되며, G2 신호는 계수 c와 승산되고, Cy 신호는 계수 d와 승산될 수 있다. 앞서 언급하였던 바와 같이 상기 계수들(a,b,c,d)을 임의적인 값으로 설정할 수 있으며, 바람직하게는 휘도 신호(Y)가 $Y = 0.26R + 0.63G + 0.11B$ 의 값으로 구해지도록 $a : b : c : d = 1.0 : 0.5 : 0.5 : 0.4$ 값이 되도록 설정할 수 있다.
 - <101> 또한, 상기와 같이 승산 처리된 칼라 신호들을 서로 합산함으로써 휘도 신호를 발생하는 단계가 수행된다(S17). 한편, 상기 칼라 신호들(Ye, G1, G2, Cy)은 칼라 보정 및 백색 밸런스 조정 등을 거치면서 그 레벨이 변동하게 된다. 이에 따라 상기 변동에 대응하여 상기 산출된 휘도 신호의 레벨도 변동하는 것이 바람직하므로 상기 휘도 신호의 게인(gain)을 조절하는 단계가 수행된다(S18). 또한, 칼라 신호들에 대해 감마 보정이 이루어지는 것에 대응하여, 상기 휘도 신호에 대한 감마 보정을 수행한다(S19). 휘도 신호에 대한 감마 보정의 특성은, 바람직하게는 상기 칼라 신호들에 대한 감마 보정과 동일한 특성을 갖도록 한다. 또한 상술하였던 바와 같이, 상기 휘도 신호에 대한 감마 보정과 칼라 신호들에 대한 감마 보정은 동일한 감마 보정 블록에서 수행될 수도 있으며, 서로 다른 감마 보정 블록에서 수행될 수도 있다.
 - <102> 도 17은 본 발명의 다른 실시예에 따른 고체 촬상 장치의 신호 처리 방법을 나타내는 플로우 차트이다. 상기 도 17에 도시된 신호 처리 방법은, 보간 처리 동작에 의해 발생할 수 있는 위색신호를 제거하기 위한 방법을 나타낸다. 상기 방법 또한 이에 대응하는 장치에 관한 설명을 통하여 상술하였으므로 자세한 설명은 생략한다.
 - <103> 도 17에 도시된 바와 같이 픽셀 어레이로부터 칼라 신호가 출력되고(S21), 상기 출력된 칼라 신호에 대해 보간 처리가 수행된다(S22).
 - <104> 보간 처리된 칼라 신호들(일례로서, Ye 신호, G 신호 및 Cy 신호)에 대하여, 위색신호가 발생한 픽셀의 위치를 검출하기 위한 소정의 연산 동작이 수행된다. 상세하게는, 동일 색의 필터를 구비하는 픽셀들 사이의 신호를 감산한다(S23). 일례로서, 픽셀 어레이의 어느 하나의 행(Ye 픽셀과 G 픽셀이 교대로 배치되는)에서, Ye 픽셀들에 대해 서로 감산 연산을 수행하고, 또한 G 픽셀들에 대해 서로 감산 연산을 수행한다. 이후, Ye 픽셀들에 대한 감산 결과와 G 픽셀들에 대한 감산 결과를 서로 합산한다(S24).
 - <105> 이후, 상기 합산 결과에 따른 신호를 픽셀 어레이의 왼쪽 방향 또는 오른쪽 방향으로 쉬프트(sfift)시킨다(S25). 또한 쉬프트(sfift)된 신호에서 그 일부의 레벨을 변동시키는 단계가 수행되며, 바람직하게는 상기 일부의 레벨을 반전시킴으로써 보정신호를 발생시킨다(S26). 상술하였던 바와 같이, 쉬프트(sfift) 동작이나 일부의 레벨을 변동시키는 동작은 상기 감산 연산의 특성(왼쪽에 배치되는 픽셀의 신호에서 오른쪽에 배치되는 픽셀의 신호를 감산할 것인지, 또는 오른쪽에 배치되는 픽셀의 신호에서 왼쪽에 배치되는 픽셀의 신호를 감산할 것인지)에 기반하여 수행될 수 있다.
 - <106> 상기와 같은 과정을 통하여 보정신호가 발생되면, 이를 이용하여 실제 위색신호를 제거하는 동작이 수행된다. 이를 위하여, 먼저 위색신호가 발생한 픽셀을 검출한 결과에 기반하여, 위색신호가 발생한 픽셀(오차 픽셀) 근방의 픽셀들을 이용하여 평균 칼라 신호(일례로서 평균 G 신호, 평균 Ye 신호 및 평균 Cy 신호)를 발생한다(S27). 상기 평균 칼라 신호가 발생되면, 상기 보정신호에 기반하여 칼라 신호(일례로서, 보간 처리된 칼라 신호)와 상기 평균 칼라 신호를 가산 또는 감산한다(S28).
 - <107> 본 발명은 도면에 도시된 실시예를 참고로 설명되었으나 이는 예시적인 것에 불과하며, 본 기술 분야의 통상의 지식을 가진 자라면 이로부터 다양한 변형 및 균등한 다른 실시예가 가능하다는 점을 이해할 것이다. 따라서, 본 발명의 진정한 기술적 보호 범위는 첨부된 특허청구범위의 기술적 사상에 의하여 정해져야 할 것이다.
- 도면의 간단한 설명*
- <108> 도 1은 일반적인 컬러 필터의 배치를 나타내는 도면이다.
 - <109> 도 2는 본 발명의 일실시예에 따른 고체 촬상 장치의 일례를 나타내는 블록도이다.
 - <110> 도 3은 도 2의 고체 촬상 장치에 구비되는 픽셀 어레이의 배열의 일례를 나타내는 도면이다.
 - <111> 도 4는 제1 녹색(Green) 필터를 갖는 픽셀이 받는 크로스 토크(Crosstalk) 성분을 나타내는 도면이다.

- <112> 도 5는 제2 녹색(Green) 필터를 갖는 픽셀이 받는 크로스 토크(Crosstalk) 성분을 나타내는 도면이다.
- <113> 도 6은 황(Yellow) 필터를 갖는 픽셀이 받는 크로스 토크(Crosstalk) 성분을 나타내는 도면이다.
- <114> 도 7은 사이언(Cyan) 필터를 갖는 픽셀이 받는 크로스 토크(Crosstalk) 성분을 나타내는 도면이다.
- <115> 도 8은 컬러 보정 동작을 설명하기 위한 고체 촬상 장치를 나타내는 회로도이다.
- <116> 도 9는 크로스 토크가 제거되는 동작을 도식적으로 나타낸 그래프이다.
- <117> 도 10은 휘도 신호 산출동작을 설명하기 위한 고체 촬상 장치를 나타내는 블록도이다.
- <118> 도 11은 본 발명의 다른 실시예에 따른 고체 촬상 장치의 동작을 설명하기 위한 픽셀 어레이를 나타내는 도면이다.
- <119> 도 12는 도 11의 픽셀 어레이에서 발생된 위색 신호를 나타내는 도면이다.
- <120> 도 13은 본 발명의 다른 실시예에 따른 고체 촬상 장치를 나타내는 블록도이다.
- <121> 도 14는 위색신호가 발생한 픽셀의 위치를 검출하고 보정 신호를 발생하는 과정을 나타내는 도면이다.
- <122> 도 15는 칼라 신호에 발생하는 위색 신호를 제거하는 과정을 나타내는 도면이다.
- <123> 도 16은 본 발명의 일실시예에 따른 고체 촬상 장치의 신호 처리 방법을 나타내는 플로우 차트이다.
- <124> 도 17은 본 발명의 다른 실시예에 따른 고체 촬상 장치의 신호 처리 방법을 나타내는 플로우 차트이다.
- <125> * 도면의 주요부분에 대한 부호의 설명 *
- <126> 100: 고체 촬상 장치
- <127> 110: 픽셀 어레이 120: 보간부
- <128> 130: 칼라 보정부 140: 백색 밸런스 조정부
- <129> 150: 감마 보정부 160: 칼라 변환부
- <130> 170: 휘도 산출부 171: 승산부
- <131> 172: 가산기 173: 게인(gain) 조절부
- <132> 174: 감마 보정부 180: RGB 변환부

도면

도면1

R	G	R	G
G	B	G	B
R	G	R	G
G	B	G	B

(a)

Ye	Cy	Ye	Cy
Mg	G	Mg	G
Ye	Cy	Ye	Cy
G	Mg	G	Mg

(b)

도면2

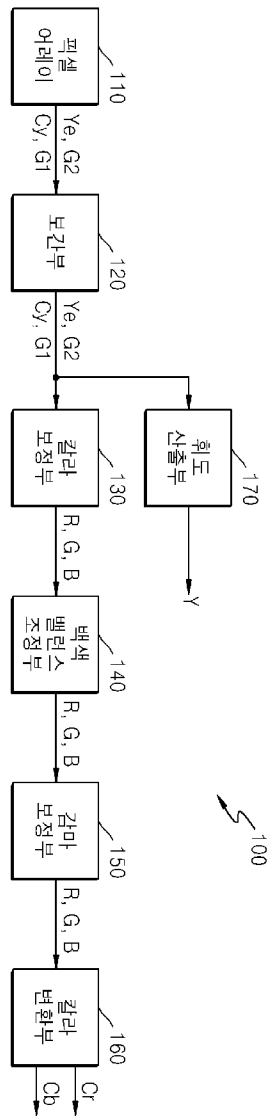

도면3

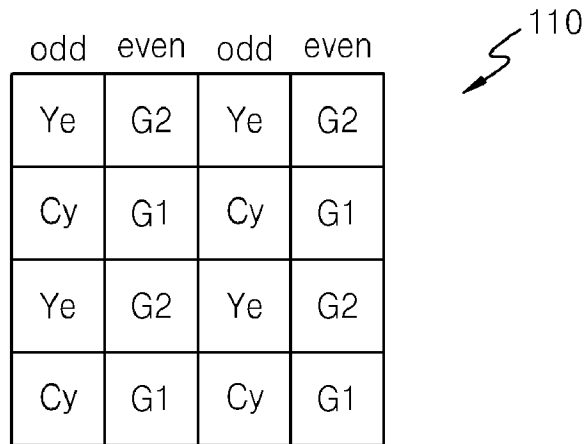

도면4a

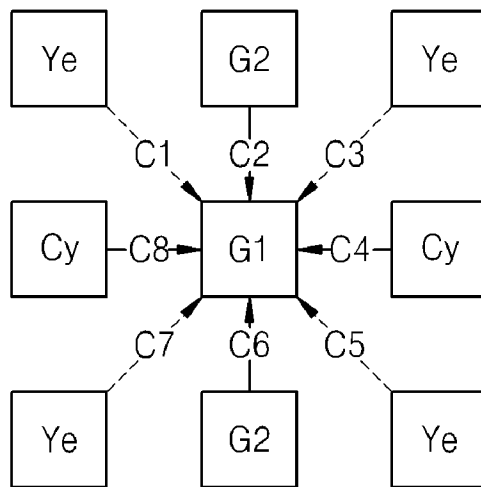

도면4b

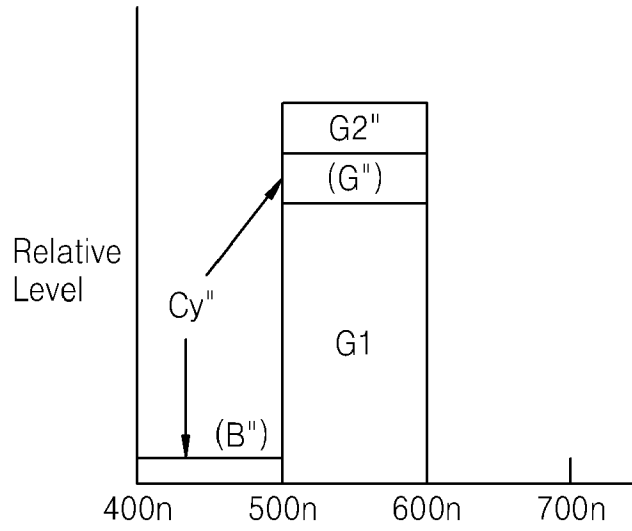

도면5a

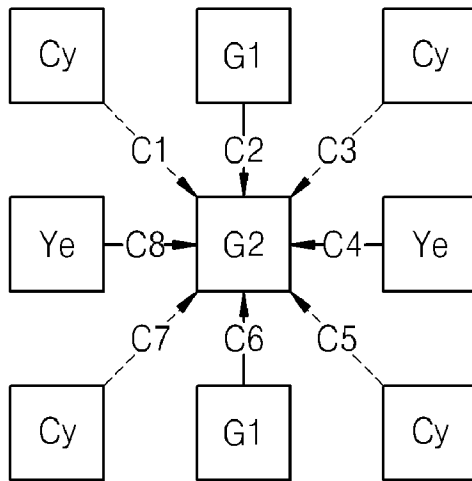

도면5b

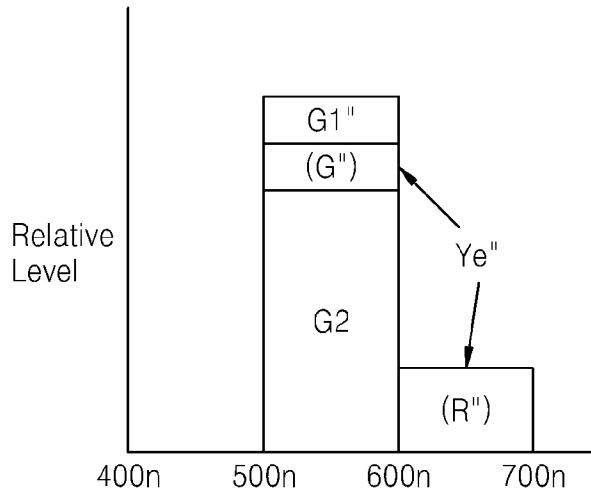

도면6a

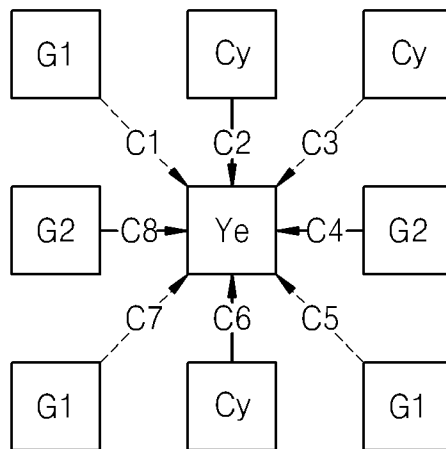

도면6b

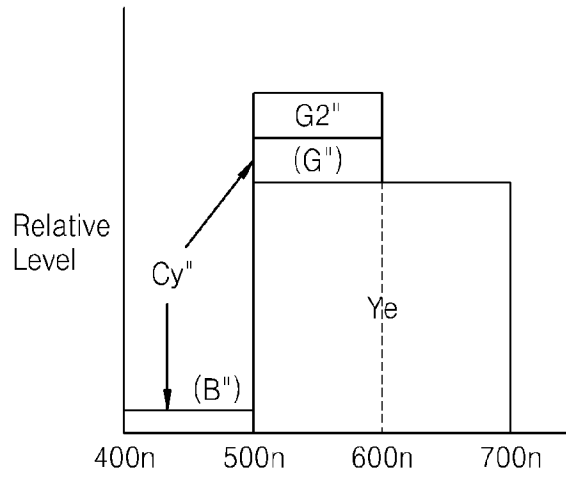

도면7a

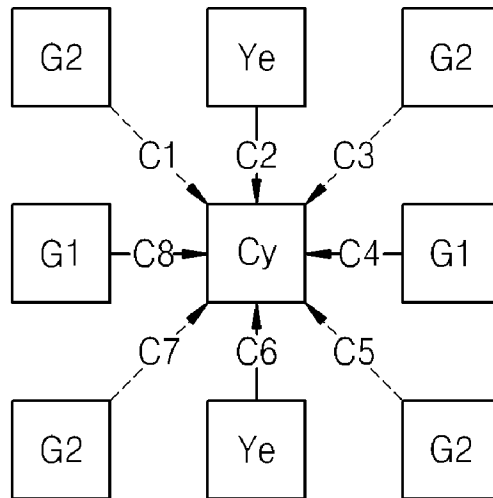

도면7b

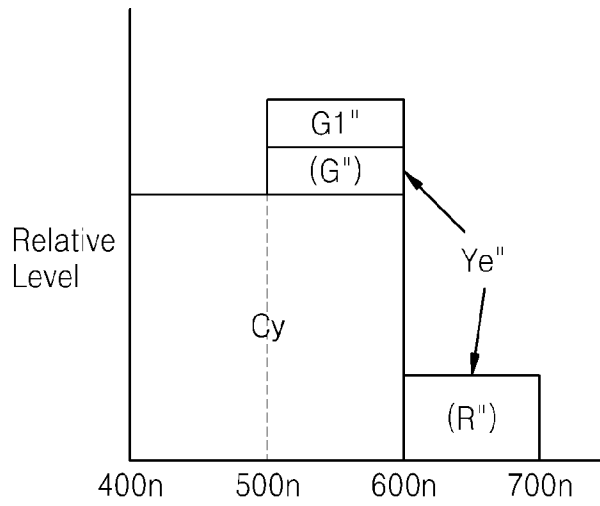

도면8

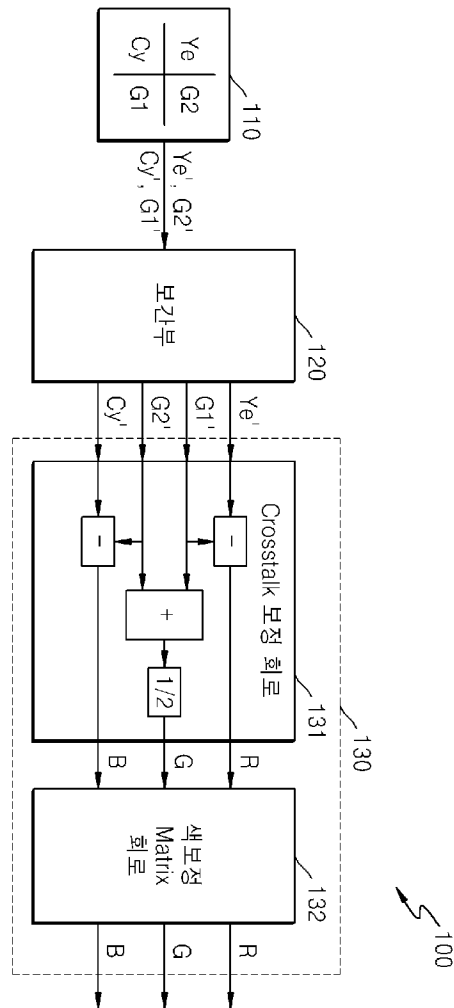

도면9a

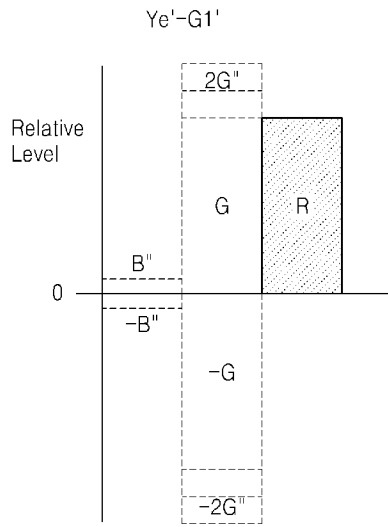

도면9b

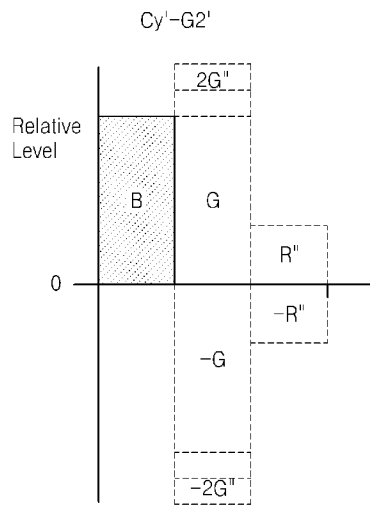

도면9c

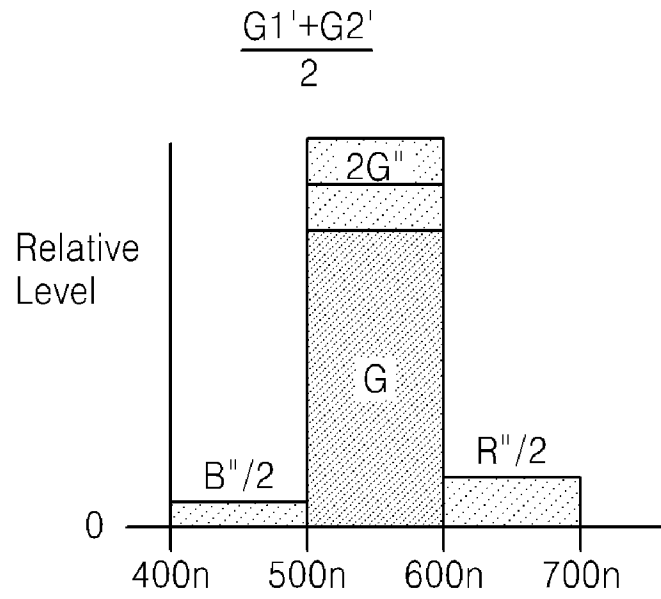

도면10

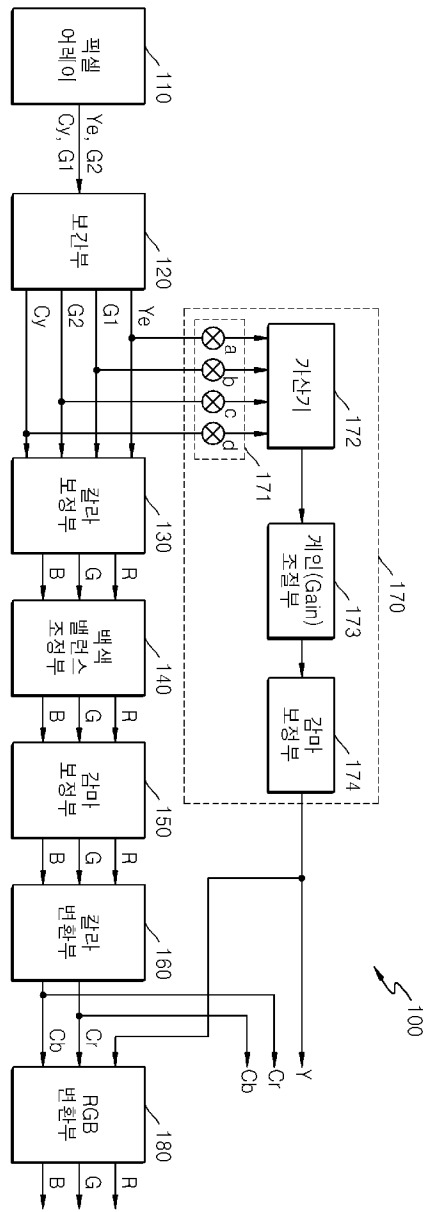

도면11

Ye11	G12	Ye13	G14	Ye15
Cy21	G22	Cy23	G24	Cy25
Ye31	G32	Ye33	G34	Ye35
Cy41	G42	Cy43	G44	Cy45
Ye51	G52	Ye53	G54	Ye55

210 ↙

도면12

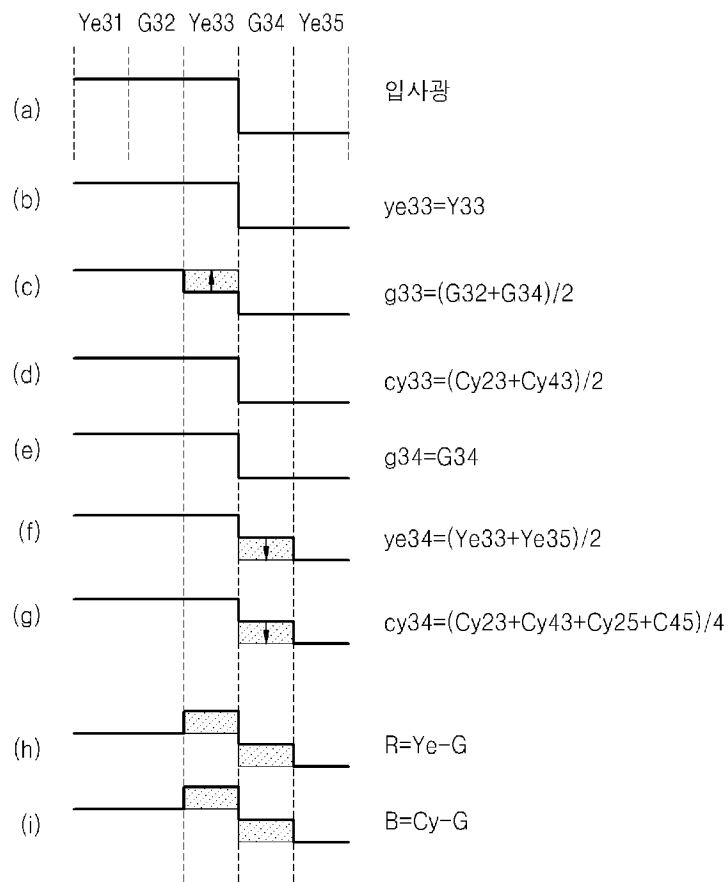

도면13

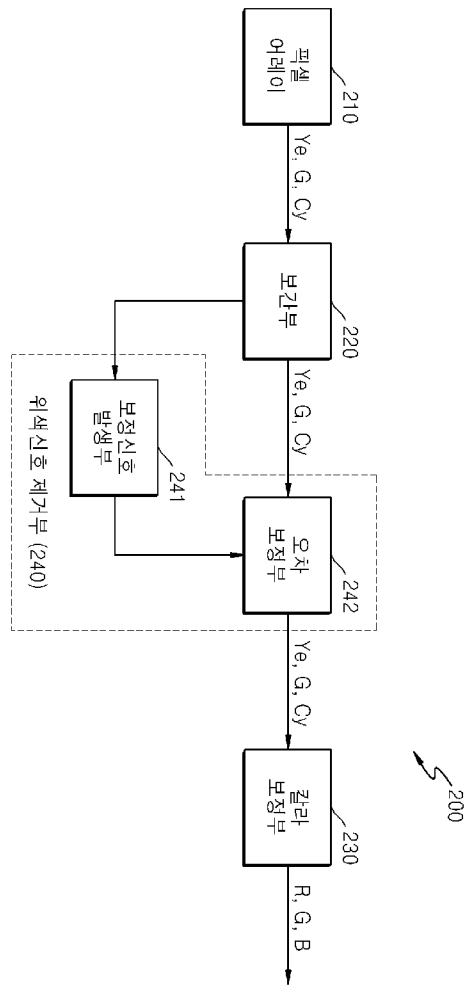

도면14

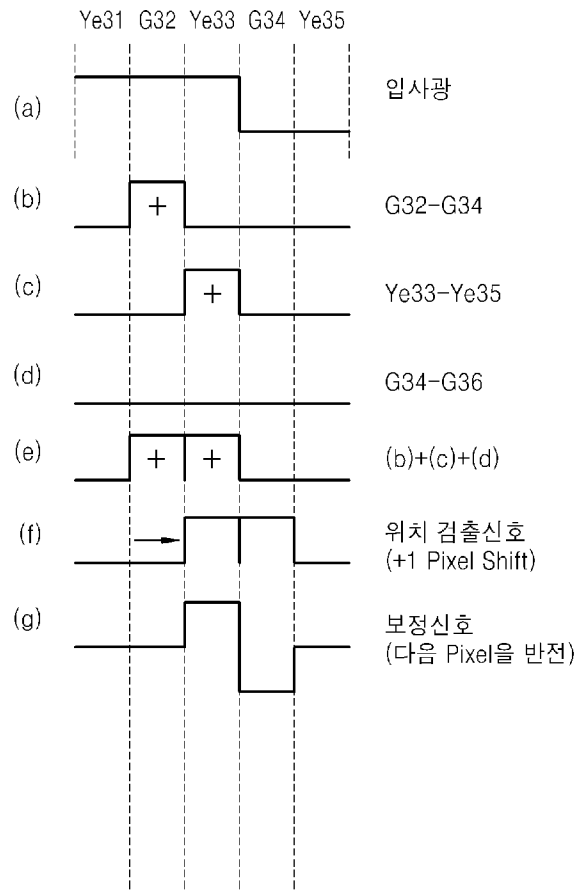

도면15

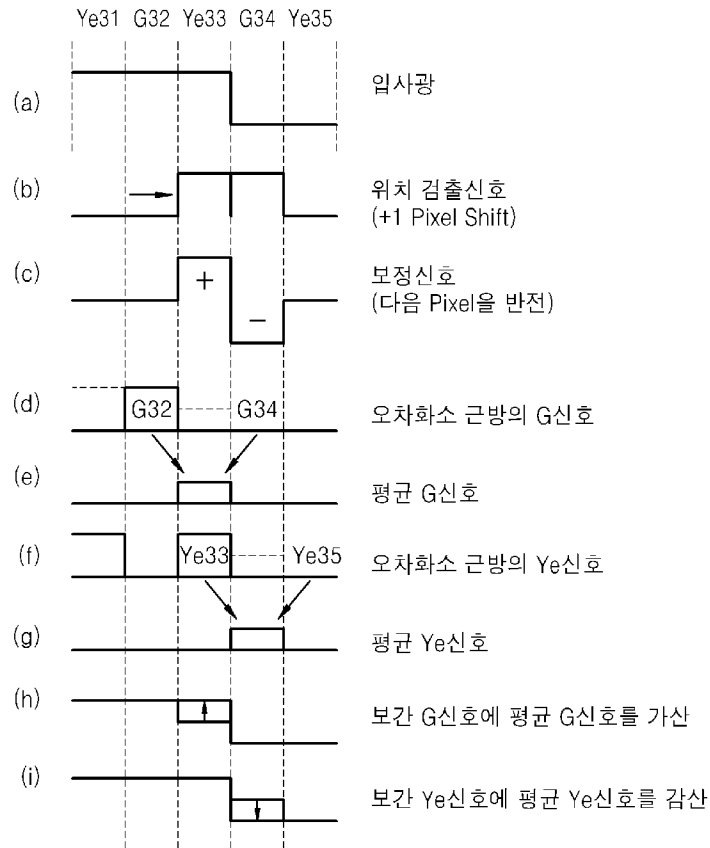

도면16

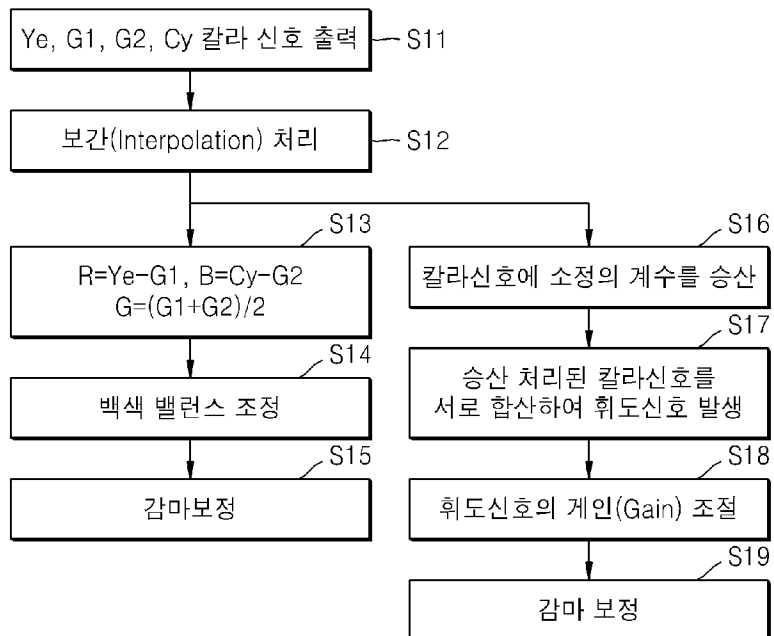

도면17

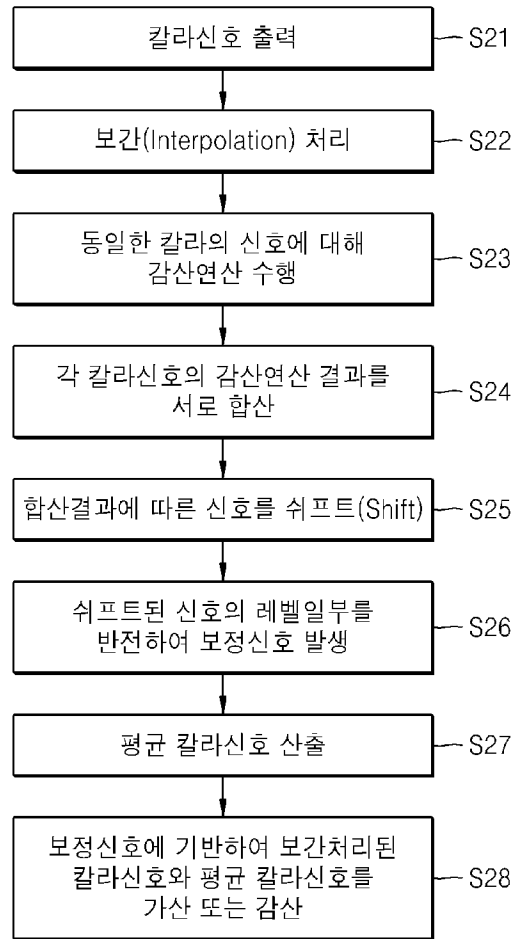

PATENT COOPERATION TREATY

From the INTERNATIONAL SEARCHING AUTHORITY

To: DELANEY, KAROLINE, A. KNOBBE, MARTENS, OLSON & BEAR, LLP 2040 MAIN STREET, 14TH FLOOR IRVINE CA 92614 USA		PCT NOTIFICATION OF TRANSMITTAL OF THE INTERNATIONAL SEARCH REPORT AND THE WRITTEN OPINION OF THE INTERNATIONAL SEARCHING AUTHORITY, OR THE DECLARATION (PCT Rule 44.1)
		Date of mailing (day/month/year) 21 May 2014 (21.05.2014)
Applicant's or agent's file reference REDCOM084WO	FOR FURTHER ACTION See paragraphs 1 and 4 below	
International application No. PCT/US2014/016301	International filing date (day/month/year) 13 February 2014 (13.02.2014)	
Applicant RED. COM, INC.		

1. The applicant is hereby notified that the international search report and the written opinion of the International Searching Authority have been established and are transmitted herewith.

Filing of amendments and statement under Article 19:

The applicant is entitled, if he so wishes, to amend the claims of the international application (see Rule 46):

When? The time limit for filing such amendments is normally two months from the date of transmittal of the international search report.

Where? Directly to the International Bureau of WIPO, 34 chemin des Colombettes
1211 Geneva 20, Switzerland, Facsimile No.: +41 22 338 82 70

For more detailed instructions, see PCT Applicant's Guide, International Phase, paragraphs 9.004 . 9.011.

2. The applicant is hereby notified that no international search report will be established and that the declaration under Article 17(2)(a) to that effect and the written opinion of the International Searching Authority are transmitted herewith.
3. **With regard to any protest** against payment of (an) additional fee(s) under Rule 40.2, the applicant is notified that:
- the protest together with the decision thereon has been transmitted to the International Bureau together with any request to forward the texts of both the protest and the decision thereon to the designated Offices.
- no decision has been made yet on the protest; the applicant will be notified as soon as a decision is made.

4. Reminders

The applicant may submit comments on an informal basis on the written opinion of the International Searching Authority to the International Bureau. The International Bureau will send a copy of such comments to all designated Offices unless an international preliminary examination report has been or is to be established. Following the expiration of 30 months from the priority date, these comments will also be made available to the public.

Shortly after the expiration of **18 months** from the priority date, the international application will be published by the International Bureau. If the applicant wishes to avoid or postpone publication, a notice of withdrawal of the international application, or of the priority claim, must reach the International Bureau before the completion of the technical preparations for international publication (Rules 90bis.1 and 90bis.3).

Within **19 months** from the priority date, but only in respect of some designated Offices, a demand for international preliminary examination must be filed if the applicant wishes to postpone the entry into the national phase **until 30 months** from the priority date (in some Offices even later); otherwise, the applicant must, **within 20 months** from the priority date, perform the prescribed acts for entry into the national phase before those designated Offices.

In respect of other designated Offices, the time limit of **30 months** (or later) will apply even if no demand is filed within 19 months.

For details about the applicable time limits, Office by Office, see www.wipo.int/pct/en/texts/time_limits.html and the PCT Applicant's Guide, National Chapters.

Name and mailing address of the ISA/KR International Application Division Korean Intellectual Property Office 189 Cheongsu-ro, Seo-gu, Daejeon Metropolitan City, 302-701, Republic of Korea Facsimile No. 82-42-472-7140	Authorized officer COMMISSIONER Telephone No. 82-42-481-5875	
--	--	---

Form PCT/ISA/220 (July 2010)

* Attention

Copies of the documents cited in the international search report can be searched in the following Korean Intellectual Property Office English website for six months(expire date : **2014.11.22**) from the date of mailing of the international search report.

<http://www.kipo.go.kr/en/> => PCT Services => PCT Services

ID : PCT international application number

PW : **3BU6U669**

Inquiries related to PCT International Search Report or Written Opinion prepared by KIPO as an International Searching Authority can be answered not only by KIPO but also through IPKC (Intellectual Property Korea Center), located in Vienna, VA, which functions as a PCT Help Desk for PCT applicants.

Homepage: <http://www.ipkcenter.com>

Email: ipkc@ipkcenter.com

PATENT COOPERATION TREATY

PCT

INTERNATIONAL SEARCH REPORT

(PCT Article 18 and Rules 43 and 44)

Applicant's or agent's file reference REDCOM084WO	FOR FURTHER ACTION see Form PCT/ISA/220 as well as, where applicable, item 5 below.	
International application No. PCT/US2014/016301	International filing date (<i>day/month/year</i>) 13 February 2014 (13.02.2014)	(Earliest) Priority Date (<i>day/month/year</i>) 14 February 2013 (14.02.2013)
Applicant RED. COM, INC.		

This International search report has been prepared by this International Searching Authority and is transmitted to the applicant according to Article 18. A copy is being transmitted to the International Bureau.

This international search report consists of a total of 3 sheets.

It is also accompanied by a copy of each prior art document cited in this report.

1. **Basis of the report**

a. With regard to the **language**, the international search was carried out on the basis of :

- the international application in the language in which it was filed
- a translation of the international application into _____, which is the language of a translation furnished for the purposes of international search (Rules 12.3(a) and 23.1(b))

b. This international search report has been established taking into account the **rectification of an obvious mistake** authorized by or notified to this Authority under Rule 91 (Rule 43.6bis(a)).

c. With regard to any **nucleotide and/or amino acid sequence** disclosed in the international application, see Box No. I.

2. **Certain claims were found unsearchable** (See Box No. II)

3. **Unity of invention is lacking** (See Box No. III)

4. With regard to the **title**,

- the text is approved as submitted by the applicant.
- the text has been established by this Authority to read as follows:

5. With regard to the **abstract**,

- the text is approved as submitted by the applicant.
- the text has been established, according to Rule 38.2, by this Authority as it appears in Box No. IV. The applicant may, within one month from the date of mailing of this international search report, submit comments to this Authority.

6. With regard to the **drawings**,

- a. the figure of the **drawings** to be published with the abstract is Figure No. 17
 - as suggested by the applicant.
 - as selected by this Authority, because the applicant failed to suggest a figure.
 - as selected by this Authority, because this figure better characterizes the invention.
- b. none of the figures is to be published with the abstract.

INTERNATIONAL SEARCH REPORT

International application No.
PCT/US2014/016301

A. CLASSIFICATION OF SUBJECT MATTER
H04N 9/07(2006.01)i, H04N 9/64(2006.01)i

According to International Patent Classification (IPC) or to both national classification and IPC

B. FIELDS SEARCHED

Minimum documentation searched (classification system followed by classification symbols)
 H04N 9/07; G09G 5/02; H04N 9/73; H04N 9/64; H04N 5/217; H04N 5/359

Documentation searched other than minimum documentation to the extent that such documents are included in the fields searched
 Korean utility models and applications for utility models
 Japanese utility models and applications for utility models

Electronic data base consulted during the international search (name of data base and, where practicable, search terms used)
 eKOMPASS(KIPO internal) & keywords: mosaic, green, average, compress

C. DOCUMENTS CONSIDERED TO BE RELEVANT



Category*	Citation of document, with indication, where appropriate, of the relevant passages	Relevant to claim No.
Y	US 2010-0265367 A1 (JAMES JANNARD et al.) 21 October 2010 See abstract; paragraphs [0043]-[0081], [0092]-[0099]; and figures 1-12.	1-21
Y	US 2008-0259180 A1 (ILIA OVSIANNIKOV) 23 October 2008 See paragraphs [0029]-[0030]; claims 1, 6; and figures 9-10.	1-21
A	US 2007-0109316 A1 (EUGENE FAINSTAIN) 17 May 2007 See abstract; claims 1-13; and figures 2-3.	1-21
A	US 2007-0165116 A1 (SZEPO ROBERT HUNG et al.) 19 July 2007 See paragraphs [0067]-[0073]; claims 1-2; and figures 6A-6B.	1-21
A	KR 10-2009-0035204 A (SAMSUNG ELECTRONICS CO., LTD.) 09 April 2009 See abstract; paragraphs [26]-[27]; claim 1; and figures 2-3.	1-21

Further documents are listed in the continuation of Box C. See patent family annex.

* Special categories of cited documents:

"A" document defining the general state of the art which is not considered to be of particular relevance	"T" later document published after the international filing date or priority date and not in conflict with the application but cited to understand the principle or theory underlying the invention
"E" earlier application or patent but published on or after the international filing date	"X" document of particular relevance; the claimed invention cannot be considered novel or cannot be considered to involve an inventive step when the document is taken alone
"L" document which may throw doubts on priority claim(s) or which is cited to establish the publication date of another citation or other special reason (as specified)	"Y" document of particular relevance; the claimed invention cannot be considered to involve an inventive step when the document is combined with one or more other such documents, such combination being obvious to a person skilled in the art
"O" document referring to an oral disclosure, use, exhibition or other means	"&" document member of the same patent family
"P" document published prior to the international filing date but later than the priority date claimed	

Date of the actual completion of the international search 19 May 2014 (19.05.2014)	Date of mailing of the international search report 21 May 2014 (21.05.2014)
---	---

Name and mailing address of the ISA/KR  International Application Division Korean Intellectual Property Office 189 Cheongsa-ro, Seo-gu, Daejeon Metropolitan City, 302-701, Republic of Korea Facsimile No. +82-42-472-7140	Authorized officer KIM, Seong Woo Telephone No. +82-42-481-3348 
---	--

INTERNATIONAL SEARCH REPORT

Information on patent family members

International application No.

PCT/US2014/016301

Patent document cited in search report	Publication date	Patent family member(s)	Publication date
US 2010-0265367 A1	21/10/2010	EP 2419879 A1 JP 2012-523790 A TW 201127059 A US 2010-0013963 A1 US 7830967 B1 US 8237830 B2 WO 2010-120472 A1	22/02/2012 04/10/2012 01/08/2011 21/01/2010 09/11/2010 07/08/2012 21/10/2010
US 2008-0259180 A1	23/10/2008	TW 200904204 A US 7876363 B2 WO 2008-130832 A1	16/01/2009 25/01/2011 30/10/2008
US 2007-0109316 A1	17/05/2007	US 7956871 B2	07/06/2011
US 2007-0165116 A1	19/07/2007	EP 1997320 A2 US 8005297 B2 WO 2007-084930 A2 WO 2007-084930 A3	03/12/2008 23/08/2011 26/07/2007 15/11/2007
KR 10-2009-0035204 A	09/04/2009	CN 101494795 A TW 200926838 A US 2009-0091647 A1 US 8144221 B2	29/07/2009 16/06/2009 09/04/2009 27/03/2012

Form PCT/ISA/210 (patent family annex) (July 2009)

PATENT COOPERATION TREATY

From the
INTERNATIONAL SEARCHING AUTHORITY

To: DELANEY, KAROLINE, A. KNOBBE, MARTENS, OLSON & BEAR, LLP 2040 MAIN STREET, 14TH FLOOR IRVINE CA 92614 USA
--

PCT

WRITTEN OPINION OF THE
INTERNATIONAL SEARCHING AUTHORITY

(PCT Rule 43bis.1)

Date of mailing (day/month/year) 21 May 2014 (21.05.2014)

Applicant's or agent's file reference REDCOM084WO	FOR FURTHER ACTION See paragraph 2 below	
International application No. PCT/US2014/016301	International filing date (day/month/year) 13 February 2014 (13.02.2014)	Priority date(day/month/year) 14 February 2013 (14.02.2013)
International Patent Classification (IPC) or both national classification and IPC H04N 9/07(2006.01)i, H04N 9/64(2006.01)i		
Applicant RED. COM, INC.		

1. This opinion contains indications relating to the following items:

- Box No. I Basis of the opinion
- Box No. II Priority
- Box No. III Non-establishment of opinion with regard to novelty, inventive step and industrial applicability
- Box No. IV Lack of unity of invention
- Box No. V Reasoned statement under Rule 43bis.1(a)(i) with regard to novelty, inventive step and industrial applicability; citations and explanations supporting such statement
- Box No. VI Certain documents cited
- Box No. VII Certain defects in the international application
- Box No. VIII Certain observations on the international application

2. **FURTHER ACTION**

If a demand for international preliminary examination is made, this opinion will be considered to be a written opinion of the International Preliminary Examining Authority ("IPEA") except that this does not apply where the applicant chooses an Authority other than this one to be the IPEA and the chosen IPEA has notified the International Bureau under Rule 66.1bis(b) that written opinions of this International Searching Authority will not be so considered.

If this opinion is, as provided above, considered to be a written opinion of the IPEA, the applicant is invited to submit to the IPEA a written reply together, where appropriate, with amendments, before the expiration of 3 months from the date of mailing of Form PCT/ISA/220 or before the expiration of 22 months from the priority date, whichever expires later.

For further options, see Form PCT/ISA/220.

Name and mailing address of the ISA/KR International Application Division Korean Intellectual Property Office 189 Cheongsa-ro, Seo-gu, Daejeon Metropolitan City, 302-701, Republic of Korea Facsimile No. +82-42-472-7140	Date of completion of this opinion 20 May 2014 (20.05.2014)	Authorized officer KIM, Seong Woo Telephone No. +82-42-481-3348	
---	--	---	---

Form PCT/ISA/237 (cover sheet) (July 2011)

WRITTEN OPINION OF THE
INTERNATIONAL SEARCHING AUTHORITY

International application No.

PCT/US2014/016301

Box No. I Basis of this opinion

1. With regard to the **language**, this opinion has been established on the basis of :
 - the international application in the language in which it was filed
 - a translation of the international application into _____ which is the language of a translation furnished for the purposes of international search (Rules 12.3(a) and 23.1(b))
2. This opinion has been established taking into account the **rectification of an obvious mistake** authorized by or notified to this Authority under Rule 91 (Rule 43*bis*.1(a))
3. With regard to any **nucleotide and/or amino acid sequence** disclosed in the international application, this opinion has been established on the basis of a sequence listing filed or furnished:
 - a. (means)
 - on paper
 - in electronic form
 - b. (time)
 - in the international application as filed.
 - together with the international application in electronic form.
 - subsequently to this Authority for the purposes of search.
4. In addition, in the case that more than one version or copy of a sequence listing has been filed or furnished, the required statements that the information in the subsequent or additional copies is identical to that in the application as filed or does not go beyond the application as filed, as appropriate, were furnished.
5. Additional comments:

**WRITTEN OPINION OF THE
INTERNATIONAL SEARCHING AUTHORITY**

International application No.
PCT/US2014/016301

Box No. V Reasoned statement under Rule 43bis.1(a)(i) with regard to novelty, inventive step or industrial applicability; citations and explanations supporting such statement

1. Statement

Novelty (N)	Claims	1-21	YES
	Claims	NONE	NO
Inventive step (IS)	Claims	NONE	YES
	Claims	1-21	NO
Industrial applicability (IA)	Claims	1-21	YES
	Claims	NONE	NO

2. Citations and explanations :

Reference is made to the following documents:

D1 : US 2010-0265367 A1 (JAMES JANNARD et al.) 21 October 2010

D2 : US 2008-0259180 A1 (ILIA OVSIANNIKOV) 23 October 2008

1. Novelty and Inventive Step

1.1 Claims 1-15

1.1.1 Independent claim 1

D1, which is considered to be the closest prior art to the subject matter of **claim 1**, discloses a method comprising accessing video data acquired by an image sensor of a camera, the video data comprising a plurality of picture element values for each of a plurality of spatially interleaved color channels, the spatially interleaved color channels comprising a first green color channel, a second green color channel, a red color channel, and a blue color channel (see paragraphs [0048]-[0049], [0080], figures 3, 8 in D1), deleting some of green image data, wherein the green image data comprises the first and second green color channels (see paragraphs [0051]-[0056], figures 4-7 in D1), modifying a value of a pixel of the red color channel or the blue color channel using an average of surrounding green elements (see paragraphs [0063]-[0067] in D1), compressing the modified red color channel or the modified blue color channel, and remaining the green image data (see paragraphs [0067], [0070]-[0072] in D1), and storing compressed video data in a storage device (24) (see paragraph [0092], figures 1, 8 in D1). Claim 1 differs from D1 in a calculated value derived from values of a plurality of picture elements of a first green color channel. However, D2 discloses determining an average of pixel signals that are local and belong to the other green color channel as a pixel being corrected (see paragraphs [0029]-[0030], claims 1, 6, figures 9-10 in D2). Accordingly, claim 1 would have been obvious over a combination of D1 and D2. Therefore, claim 1 lacks an inventive step under PCT Article 33(3).

Continued on Supplemental Box

WRITTEN OPINION OF THE
INTERNATIONAL SEARCHING AUTHORITY

International application No.
PCT/US2014/016301

Box No. VIII Certain observations on the international application

The following observations on the clarity of the claims, description, and drawings or on the question whether the claims are fully supported by the description, are made:

The phrase "transforming the second green color channel least partly by" of claim 18 is considered to be a typo of "transforming the second green color channel at least partly by". Therefore, claim 18 does not meet the requirements of PCT Article 6.

Supplemental Box

In case the space in any of the preceding boxes is not sufficient.
Continuation of: Box No. V

1.1.2 Dependent claims 2-15

The additional feature of **claim 2** is identical to the feature of D1 in subtraction of green magnitudes (see paragraphs [0061]-[0065] in D1).

The additional features of **claims 3-9** are identical to the features of D2 in the average of pixel signals that are local and belong to the other green color channel as the pixel being corrected (see paragraphs [0029]-[0030], claims 1, 6, figures 9-10 in D2).

The additional features of **claims 10-11** are identical to the features of D1 in a Bayer pattern filter (see paragraph [0081] in D1).

The additional feature of **claim 12** is identical to the feature of D1 in a subtraction technique using the correlation of picture elements to achieve better compression (see paragraph [0062] in D1).

The additional feature of **claim 13** is identical to the feature of D1 in inserting flags indicating what portions of image data have been modified (by e.g., green image data subtraction) and which portions have not been so modified (see paragraph [0064] in D1).

The additional feature of **claim 14** is identical to the feature of D1 in modifying the value of the pixel of the red color channel or the blue color channel using the average of surrounding the green elements (see paragraphs [0063]-[0067] in D1).

The additional feature of **claim 15** is identical to the feature of D1 in the subtraction technique using the correlation of picture elements to achieve the better compression (see paragraph [0062] in D1).

Accordingly, **claims 2-15** would have been obvious over a combination of D1 and D2. Therefore, claims 2-15 lack an inventive step under PCT Article 33(3).

1.2 Claim 16

1.2.1 Independent claim 16

D1, which is considered to be the closest prior art to the subject matter of **claim 16**, discloses a video camera comprising a storage device (24) (see paragraph [0043], figure 1 in D1), an image sensor (18) configured to convert light into video data, the video data comprising a plurality of picture element values for each of a plurality of spatially interleaved color channels, the spatially interleaved color channels comprising a first green color channel, a second green color channel, a red color channel, and a blue color channel (see paragraphs [0043], [0048]-[0049], [0080], figures 1, 3, 8 in D1), and an image processing module (20) configured to delete some of green image data, wherein the green image data comprises the first and second green color channels (see paragraphs [0051]-[0056], figures 1, 4-7 in D1), modify a value of a pixel of the red color channel or the blue color channel using an average of surrounding green elements (see paragraphs [0063]-[0067] in D1), compress the modified red color

Continued on The Next Page

Supplemental Box

In case the space in any of the preceding boxes is not sufficient.
Continuation of: Previous Page

channel or the modified blue color channel, and remaining green image data (see paragraphs [0067], [0070]-[0072] in D1), and store compressed video data in the storage device (24) (see paragraph [0092], figures 1, 8 in D1). Claim 16 differs from D1 in a calculated value derived from values of a plurality of picture elements of a first green color channel. However, D2 discloses determining an average of pixel signals that are local and belong to the other green color channel as a pixel being corrected (see paragraphs [0029]-[0030], claims 1, 6, figures 9-10 in D2). Accordingly, claim 16 would have been obvious over a combination of D1 and D2. Therefore, claim 16 lacks an inventive step under PCT Article 33(3).

1.3 Claim 17

1.3.1 Independent claim 17

D1, which is considered to be the closest prior art to the subject matter of **claim 17**, discloses a video camera comprising a storage device (24) (see paragraph [0043], figure 1 in D1), a processor (see paragraphs [0067]-[0068] in D1) and an image processing module (20) configured to access video data acquired by an image sensor of a camera, the video data comprising a plurality of picture element values for each of a plurality of spatially interleaved color channels, the spatially interleaved color channels comprising a first green color channel, a second green color channel, a red color channel, and a blue color channel (see paragraphs [0043], [0048]-[0049], [0080], figures 1, 3, 8 in D1), delete some of green image data, wherein the green image data comprises the first and second green color channels (see paragraphs [0051]-[0056], figures 1, 4-7 in D1), modify a value of a pixel of the red color channel or the blue color channel using an average of surrounding green elements (see paragraphs [0063]-[0067] in D1), and compress the modified red color channel or the modified blue color channel, and remaining green image data (see paragraphs [0067], [0070]-[0072] in D1). Claim 17 differs from D1 in a calculated value derived from values of a plurality of picture elements of a first green color channel. However, D2 discloses determining an average of pixel signals that are local and belong to the other green color channel as a pixel being corrected (see paragraphs [0029]-[0030], claims 1, 6, figures 9-10 in D2). Accordingly, claim 17 would have been obvious over a combination of D1 and D2. Therefore, claim 17 lacks an inventive step under PCT Article 33(3).

1.4 Claims 18-21

1.4.1 Independent claim 18

D1, which is considered to be the closest prior art to the subject matter of **claim 18**, discloses a method comprising applying decompression algorithm to compressed video data for green picture elements (see

Continued on The Next Page

Supplemental Box

In case the space in any of the preceding boxes is not sufficient.

Continuation of: Previous Page

paragraph [0097], figure 12 in D1), wherein the compressed video data was compressed by deleting some of green image data, wherein the green image data comprises first and second green color channels (see paragraphs [0051]-[0056], figures 1, 4-7 in D1), modifying a value of a pixel of a red color channel or a blue color channel using an average of surrounding green elements (see paragraphs [0063]-[0067] in D1) and compressing the modified red color channel or the modified blue color channel, and remaining green image data (see paragraphs [0067], [0070]-[0072] in D1), and demosaicing the green picture elements (see paragraphs [0097]-[0099], figure 12 in D1). Claim 18 differs from D1 in a calculated value derived from values of a plurality of picture elements of a first green color channel. However, D2 discloses determining an average of pixel signals that are local and belong to the other green color channel as a pixel being corrected (see paragraphs [0029]-[0030], claims 1, 6, figures 9-10 in D2). Accordingly, claim 18 would have been obvious over a combination of D1 and D2. Therefore, claim 18 lacks an inventive step under PCT Article 33(3).

1.4.2 Dependent claims 19-21

Claims 19-21 further specify that a decoding comprises substantially reversing a transform operation and performing a decompression operation. However, the additional features of claims 19-21 are virtually suggested by the features of D1 considering demosaicing of the green picture elements, demosaicing of red and blue picture elements, and reconstructing of the red and blue picture elements (see paragraphs [0097]-[0099], figure 12 in D1). Accordingly, claims 19-21 would have been obvious over a combination of D1 and D2. Therefore, claims 19-21 lack an inventive step under PCT Article 33(3).

2. Industrial Applicability

Claims 1-21 are industrially applicable under PCT Article 33(4).

Electronic Acknowledgement Receipt

EFS ID:	20354934
Application Number:	14485612
International Application Number:	
Confirmation Number:	1068
Title of Invention:	VIDEO CAMERA
First Named Inventor/Applicant Name:	James H. Jannard
Customer Number:	20995
Filer:	Sean Patrick Ambrosius/Jennifer Brown
Filer Authorized By:	Sean Patrick Ambrosius
Attorney Docket Number:	REDCOM.007C4
Receipt Date:	07-OCT-2014
Filing Date:	12-SEP-2014
Time Stamp:	19:01:21
Application Type:	Utility under 35 USC 111(a)

Payment information:

Submitted with Payment	no
------------------------	----

File Listing:

Document Number	Document Description	File Name	File Size(Bytes)/ Message Digest	Multi Part /.zip	Pages (if appl.)
1		REDCOM-007C4_IDS.pdf	869029 <small>35c43ef0e847054fa777612347bf0ed5f3c05d2d</small>	yes	17

Multipart Description/PDF files in .zip description					
Document Description			Start	End	
Transmittal Letter			1	3	
Information Disclosure Statement (IDS) Form (SB08)			4	17	
Warnings:					
Information:					
2	Foreign Reference	WO92-010911.pdf	2851458 f06e57dc04014fa630580b82626d2b67c6b701c3	no	79
Warnings:					
Information:					
3	Foreign Reference	KR_10-2009-0035204_w-Abs.pdf	1152795 816d664a8a59b0586b63a6501126b9897d38d9ec	no	33
Warnings:					
Information:					
4	Non Patent Literature	2014-05-21_ISR-WO_REDCOM-084WO.pdf	708006 95fd519dcb8a5b46d7730ae1ae635093c2d9355b	no	12
Warnings:					
Information:					
5	Non Patent Literature	2014-07-15_Official-Communication_TW0971136289_REDCOM-007VTW.pdf	127296 32c38e6332e4aa17f896864182a2192327c3db93	no	4
Warnings:					
Information:					
6	Non Patent Literature	2014-08-22_ESR_App-No-14177071-9_REDCOM-007V EPD1.pdf	863354 bc2ccac554d76cd025689b3e248267d2f7144553	no	11
Warnings:					
Information:					
7	Non Patent Literature	2014-07-31_AU-Exam-Report_App-No-2012216606_REDCOM-007 VAUD1.pdf	41580 03b95049d1bf930ec0e8c5ecf6bbd842735675be	no	3
Warnings:					
Information:					
8	Non Patent Literature	2014-07-14_Official-Communication_EP10726688-4_REDCOM-007QEP.pdf	558603 dc4f6bb04ce6b69af222c1b9ea63f7d65944124e	no	5
Warnings:					
Information:					

9	Non Patent Literature	POYNTON- A_Technical_Introduction.pdf	1875208 1987bfa3e4c4c9088a72e7b66a67eb9f2129315d	no	24
---	-----------------------	--	---	----	----

Warnings:

Information:

Total Files Size (in bytes):	9047329
-------------------------------------	---------

This Acknowledgement Receipt evidences receipt on the noted date by the USPTO of the indicated documents, characterized by the applicant, and including page counts, where applicable. It serves as evidence of receipt similar to a Post Card, as described in MPEP 503.

New Applications Under 35 U.S.C. 111

If a new application is being filed and the application includes the necessary components for a filing date (see 37 CFR 1.53(b)-(d) and MPEP 506), a Filing Receipt (37 CFR 1.54) will be issued in due course and the date shown on this Acknowledgement Receipt will establish the filing date of the application.

National Stage of an International Application under 35 U.S.C. 371

If a timely submission to enter the national stage of an international application is compliant with the conditions of 35 U.S.C. 371 and other applicable requirements a Form PCT/DO/EO/903 indicating acceptance of the application as a national stage submission under 35 U.S.C. 371 will be issued in addition to the Filing Receipt, in due course.

New International Application Filed with the USPTO as a Receiving Office

If a new international application is being filed and the international application includes the necessary components for an international filing date (see PCT Article 11 and MPEP 1810), a Notification of the International Application Number and of the International Filing Date (Form PCT/RO/105) will be issued in due course, subject to prescriptions concerning national security, and the date shown on this Acknowledgement Receipt will establish the international filing date of the application.

INFORMATION DISCLOSURE STATEMENT

Inventor	: James H. Jannard
App. No.	: 14/485612
Filed	: September 12, 2014
For	: VIDEO CAMERA
Examiner	: Unknown
Art Unit	: 2661
Conf. No.	: 1068

Commissioner for Patents
P.O. Box 1450
Alexandria, VA 22313-1450

References and Listing

Submitted herewith in the above-identified application is an Information Disclosure Statement listing references for consideration. Listed foreign and non-patent literature references corresponding to reference numbers 169-189 and 192-299 are of record in U.S. patent application No. 13/464803, filed May 4, 2012, which is relied upon for an earlier filing date under 35 USC 120. Copies of the references are not submitted pursuant to 37 CFR 1.98(d). However, Applicant would be happy to provide references upon request.

For certain cited non-English patent and/or non-patent references, machine translations of the references (and/or Abstracts) are included, and inclusion is indicated in the last column. Applicant makes no representation as to the accuracy of the English machine translations. If the Examiner would like additional information regarding these references or if anything is unclear, the Examiner is invited to request such information, and Applicant will attempt to comply with any such request.

Applicant wishes to draw the Examiner's attention to the following applications owned by of the present application's assignee:

Docket No.	Serial No.	Patent/ Publication No.	Title	Filed
REDCOM.007A	12/101,882	8,174,560	VIDEO CAMERA	04/11/2008
REDCOM.007C1	13/464,803	2012/0294582	VIDEO CAMERA	05/04/2012
REDCOM.007C2	13/566,868	8,358,357	VIDEO CAMERA	08/03/2012
REDCOM.007C3	14/485,611	N/A	VIDEO CAMERA	09/12/2014
REDCOM.007CP1	12/422,507	8,237,830	VIDEO CAMERA	04/13/2009
REDCOM.007CP1C1	12/834,854	7,830,967	VIDEO CAMERA	07/12/2010

Application No.: 14/485612
Filing Date: September 12, 2014

Docket No.	Serial No.	Patent/ Publication No.	Title	Filed
REDCOM.007CP1C2	13/566,924	2013/0113951	VIDEO CAMERA	08/03/2012
REDCOM.007P1C3	14/488,030	N/A	VIDEO CAMERA	09/16/2014
REDCOM.007X1 (reexamination of REDCOM.007A)	90/012,550	8,174,560 C1	VIDEO CAMERA	09/13/2012

Applicant notes that cited references, office actions, responses and notices of allowance currently exist or will exist for the above-referenced matters. Applicant also understands that the Examiner has access to sophisticated online Patent Office computing systems that provide ready access to the full file histories of these matters including, for example, specifications, drawings, pending claims, cited art, office actions, responses, declarations, and notices of allowance. Rather than submit copies these file histories, Applicant respectfully requests that the Examiner continue to review these file histories online for past, current, and future information about these matters. Also, if the Examiner cannot readily access these file histories, the Applicant would be pleased to provide any portion of any of the file histories at any time upon specific Examiner request.

The present application relies on co-owned U.S. Patent Application Serial No. 12/101,882 for an earlier filing date under 35 USC 120. U.S. Patent No. 8,174,560 issued from the '882 application, and U.S. Patent No. 8,358,357 relies on the '882 application for an earlier filing date under 35 U.S.C. § 120. Out of an abundance of caution, Applicant wishes to make the Examiner aware that the '560 patent and the '357 patent were involved in the following proceeding, which was subsequently dismissed and is no longer pending: *RED.COM, INC., Inc. v. Sony Corporation of America and Sony Electronics, Inc.*, U.S. District Court for the Southern District of California, Case No.: 3:13-cv-00334-DMS-BGS. The complaint is being submitted herewith, corresponding to reference number 241.

In addition, the listed references include a number of on-line discussion threads (including those corresponding to reference numbers 243-269) posted on two websites: www.dvxuser.com and www.hdforindies.com ("the Websites"). Each discussion thread generally consists of a chronological string of individual posts, made by various authors at different times. The Websites noted above also contain other threads, are believed to be presently operational, and are full-text searchable.

Pursuant to 37 C.F.R § 1.97(g) and (h), Applicants make no representation that the information is considered to be material to patentability. Additionally, inclusion on this list is not an admission that any of the cited documents are prior art in this application. Further, Applicants make no representation regarding the completeness of this list, or that better art does not exist.

Application No.: 14/485612
Filing Date: September 12, 2014

Timing of Disclosure

This Information Disclosure Statement is being filed within three months of the filing date or date of national phase entry, with an RCE or before receipt of a First Office Action after an RCE, and no fee is required.

The Commissioner is hereby authorized to charge any additional fees which may be required, or credit any overpayment, to Account No. 11-1410.

Respectfully submitted,
KNOBBE, MARTENS, OLSON & BEAR, LLP

Dated: October 7, 2014

By: /Sean Ambrosius/ _____
Sean Ambrosius
Registration No. 65,290
Attorney of Record
Customer No. 20995
(949) 760-0404

18876909

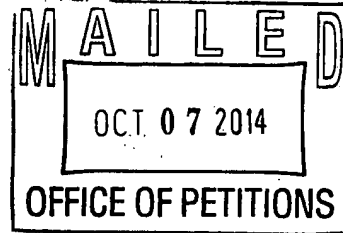

KNOBBE MARTENS OLSON & BEAR LLP
2040 MAIN STREET
FOURTEENTH FLOOR
IRVINE CA 92614

Decision Granting Request for Prioritized Examination (Track I or After RCE)	Application No.:14/485,612
<p>1. THE REQUEST FILED <u>September 12, 2014</u> IS GRANTED.</p> <p>The above-identified application has met the requirements for prioritized examination</p> <p>A. <input checked="" type="checkbox"/> for an original nonprovisional application (Track I).</p> <p>B. <input type="checkbox"/> for an application undergoing continued examination (RCE).</p> <p>2. The above-identified application will undergo prioritized examination. The application will be accorded special status throughout its entire course of prosecution until one of the following occurs:</p> <p>A. filing a <u>petition for extension of time</u> to extend the time period for filing a reply;</p> <p>B. filing an <u>amendment to amend the application to contain more than four independent claims, more than thirty total claims</u>, or a multiple dependent claim;</p> <p>C. filing a <u>request for continued examination</u>;</p> <p>D. filing a notice of appeal;</p> <p>E. filing a request for suspension of action;</p> <p>F. mailing of a notice of allowance;</p> <p>G. mailing of a final Office action;</p> <p>H. completion of examination as defined in 37 CFR 41.102; or</p> <p>I. abandonment of the application.</p> <p>Telephone inquiries with regard to this decision should be directed to Kimberly Inabinet at 571-272-4618.</p> <p>/ Kimberly Inabinet/ Paralegal Specialist, Office of Petitions</p>	



UNITED STATES PATENT AND TRADEMARK OFFICE

UNITED STATES DEPARTMENT OF COMMERCE
United States Patent and Trademark Office
Address: COMMISSIONER FOR PATENTS
P.O. Box 1450
Alexandria, Virginia 22313-1450
www.uspto.gov

Table with 5 columns: APPLICATION NO., FILING DATE, FIRST NAMED INVENTOR, ATTORNEY DOCKET NO., CONFIRMATION NO.
Row 1: 14/485,612, 09/12/2014, James H. Jannard, REDCOM.007C4, 1068
Row 2: 20995, 7590, 11/17/2014, KNOBBE MARTENS OLSON & BEAR LLP, 2040 MAIN STREET, FOURTEENTH FLOOR, IRVINE, CA 92614, EXAMINER, DIEP, TRUNG T
Row 3: ART UNIT, PAPER NUMBER, 2664
Row 4: NOTIFICATION DATE, DELIVERY MODE, 11/17/2014, ELECTRONIC

Please find below and/or attached an Office communication concerning this application or proceeding.

The time period for reply, if any, is set in the attached communication.

Notice of the Office communication was sent electronically on above-indicated "Notification Date" to the following e-mail address(es):

jayna.cartee@knobbe.com
efiling@knobbe.com

Office Action Summary	Application No. 14/485,612	Applicant(s) JANNARD ET AL.	
	Examiner TRUNG DIEP	Art Unit 2664	AIA (First Inventor to File) Status No

-- The MAILING DATE of this communication appears on the cover sheet with the correspondence address --

Period for Reply

A SHORTENED STATUTORY PERIOD FOR REPLY IS SET TO EXPIRE 3 MONTHS FROM THE MAILING DATE OF THIS COMMUNICATION.

- Extensions of time may be available under the provisions of 37 CFR 1.136(a). In no event, however, may a reply be timely filed after SIX (6) MONTHS from the mailing date of this communication.
- If NO period for reply is specified above, the maximum statutory period will apply and will expire SIX (6) MONTHS from the mailing date of this communication.
- Failure to reply within the set or extended period for reply will, by statute, cause the application to become ABANDONED (35 U.S.C. § 133). Any reply received by the Office later than three months after the mailing date of this communication, even if timely filed, may reduce any earned patent term adjustment. See 37 CFR 1.704(b).

Status

- 1) Responsive to communication(s) filed on 09/12/2014.
 A declaration(s)/affidavit(s) under **37 CFR 1.130(b)** was/were filed on _____.
- 2a) This action is **FINAL**. 2b) This action is non-final.
- 3) An election was made by the applicant in response to a restriction requirement set forth during the interview on _____; the restriction requirement and election have been incorporated into this action.
- 4) Since this application is in condition for allowance except for formal matters, prosecution as to the merits is closed in accordance with the practice under *Ex parte Quayle*, 1935 C.D. 11, 453 O.G. 213.

Disposition of Claims*

- 5) Claim(s) 1-30 is/are pending in the application.
5a) Of the above claim(s) _____ is/are withdrawn from consideration.
- 6) Claim(s) _____ is/are allowed.
- 7) Claim(s) _____ is/are rejected.
- 8) Claim(s) _____ is/are objected to.
- 9) Claim(s) _____ are subject to restriction and/or election requirement.

* If any claims have been determined allowable, you may be eligible to benefit from the **Patent Prosecution Highway** program at a participating intellectual property office for the corresponding application. For more information, please see http://www.uspto.gov/patents/init_events/pph/index.jsp or send an inquiry to PPHfeedback@uspto.gov.

Application Papers

- 10) The specification is objected to by the Examiner.
- 11) The drawing(s) filed on 09/12/2014 is/are: a) accepted or b) objected to by the Examiner.
Applicant may not request that any objection to the drawing(s) be held in abeyance. See 37 CFR 1.85(a).
Replacement drawing sheet(s) including the correction is required if the drawing(s) is objected to. See 37 CFR 1.121(d).

Priority under 35 U.S.C. § 119

- 12) Acknowledgment is made of a claim for foreign priority under 35 U.S.C. § 119(a)-(d) or (f).

Certified copies:

- a) All b) Some** c) None of the:
 - 1. Certified copies of the priority documents have been received.
 - 2. Certified copies of the priority documents have been received in Application No. _____.
 - 3. Copies of the certified copies of the priority documents have been received in this National Stage application from the International Bureau (PCT Rule 17.2(a)).

** See the attached detailed Office action for a list of the certified copies not received.

Attachment(s)

- 1) Notice of References Cited (PTO-892)
- 2) Information Disclosure Statement(s) (PTO/SB/08a and/or PTO/SB/08b)
Paper No(s)/Mail Date _____
- 3) Interview Summary (PTO-413)
Paper No(s)/Mail Date. _____
- 4) Other: _____

Art Unit: 2664

1. The present application is being examined under the pre-AIA first to invent provisions.

DETAILED ACTION

Information Disclosure Statement

2. The information disclosure statement (IDS) submitted on 10/07/2014 is in compliance with the provisions of 37 CFR 1.97. Accordingly, the information disclosure statement is being considered by the examiner.

Claim Objections

3. Claims 16-19 are objected to because of the following informalities: In the claim list, independent claim 16, on page 27, line 21, the "**at**" is missing in this sentence. It should be read as "converting the light received by the image sensor into mosaiced image data at a resolution of at least 2k and at a frame rate of at least about 23 frames per second, the mosaiced image data comprising one data value for each of the light sensitive devices included in the first, second, and third pluralities of light sensitive devices; ". Note that the "**at**" are also missing in dependent claims 17, 18 and 19.

Appropriate correction is required.

Claim Rejections - 35 USC § 103

4. The following is a quotation of pre-AIA 35 U.S.C. 103(a) which forms the basis for all obviousness rejections set forth in this Office action:

(a) A patent may not be obtained though the invention is not identically disclosed or described as set forth in section 102 of this title, if the differences between the subject matter sought to be patented and the prior art are such that the subject matter as a whole would have been obvious at the time the invention was made to a person having ordinary skill in the art to which

Art Unit: 2664

said subject matter pertains. Patentability shall not be negated by the manner in which the invention was made.

5. Claims 1– 30 are rejected under pre-AIA 35 U.S.C. 103(a) as being unpatentable over Ishii (US 7,898,575 B2) in view of Newman (US 8,014,597 B1), cited by the applicant.

As to claim 1, *Ishii discloses in figures 1-25, a video camera (i.e., image pickup device and image recording apparatus for recording moving image data, see abstract, Col. 4, line 44 to Col. 6, line 38 and Col. 17, line 24 to Col. 22, line 41), comprising:*

a portable (1a) housing having an opening through (102) which light emanating from outside the portable housing enters the portable housing (i.e., see figure 1, Col.4, line 44 to Col. 5, line 49);

a memory device (109a – 109d) supported by the portable housing (i.e., i.e., see Col. 22, lines15-30);

an image sensor (103) comprising first, second, and third pluralities of light sensitive (RGB) devices arranged with respect to one another in a plane defined by the image sensor such that the first, second, and third pluralities of light sensitive devices are intermingled, defining an intermingled pattern (i.e., Bayer arranged sensor, see figures 1 -2, Col. 5, line 30 to Col. 6, line 3), the first, second, and third pluralities of light sensitive devices being configured to detect first, second, and third colors, respectively, the first, second, and third colors being different from each other (i.e., RGB sensor, see figures 1 -2, Col. 5, line 30 to Col. 6, line 3),

Art Unit: 2664

the image sensor being configured to convert light entering the portable housing through the opening into mosaiced image data (*i.e., performed Bayer interpolation and color correction*) comprising one data value for each of the light sensitive devices included in the first, second, and third pluralities of light sensitive devices, the image sensor being configured to output the mosaiced image data at a resolution of at least 2k and at a frame rate of at least about 23 frames per second (*i.e., Bayer arranged sensor wherein pickup mode is set for image size 4096 X 2160 at a frame rate of 60 fps, see figures 1 -4, Col. 5, line 30 to Col. 7, line 17*); and

electronics having an image processing module (104) and a compression module (112a – 112d) implemented therein (*i.e., see figure 24, Col. 20, line 59 to Col. 21, line 40*), the image processing module (104) connected between the image sensor (103) and the memory device (109a – 109d), the image processing module configured to process the mosaiced image data from the image sensor and output processed image data based on the mosaiced image data from the image sensor, the processed image data including less than three data values for each of the light sensitive devices included in the first, second, and third pluralities of light sensitive devices (*RGB sensor*) (*i.e., Bayer-arranged sensor, see figure 2, Col. 5, line 50 to Col. 6, line 3*); and

the compression module (112a – 112d) connected between the image sensor (103) and the memory device (109a – 109d), the compression module configured to compress the processed image data with a mathematically lossy compression technique into compressed processed image data such that the compressed processed image data can be decompressed (113a – 113d) into a substantially visually lossless

Art Unit: 2664

image of at least 2k resolution, wherein the memory device (109a – 109d) receives the compressed processed image data at a rate of at least about 23 frames per second (i.e., see Col.22, lines 15-41).

Ishii **is silent** as RAW data and the image demosaiced processing.

However, *Newman teaches in figures 1-8*, relates to an invention allows for video images from Bayer-style cameras to be processed in high resolution far more efficiently than the current state of the art, and the method for effecting RAW Bayer compression using a camera by itself or an external device that performs the Bayer compression. The interleaved color components within a Bayer sensor are typically arranged in 2.times.2 pixel squares over the entire image with red and green on the top pair, and green and blue on the bottom of each 2.times.2 pixel array. This pattern of interleaved red, green and blue pixels is problematic for compression as a single image because the spatially-adjacent pixels are much less correlated and therefore less compressible than a plane of monochrome data. Compression operates most effectively when adjacent pixels have a high likelihood of being similar, yet in a Bayer image the adjacent pixels are filtered for different color primaries, so pixel magnitudes will vary greatly. Attempting direct compression of a Bayer image using common techniques such as DCT or wavelet compression will either result in little or no reduction of data size, or a significant amount of image distortion. This invention allows higher compression without introducing visually-damaging distortion of the image, using existing compression technologies like DCT and wavelet. Newman further discloses the de-Bayer filtering (or demosaicing) is the process of interpolating the missing color

Art Unit: 2664

components at every pixel location. As acquired, the Bayer sensor only collects one of the three color primaries at every pixel site--the two other primaries are predicted via a range of different algorithms that typically take substantial compute time for high quality results. In the above 1920.times.1080 encoding example, the compressed video image produced will be smaller in data size yet higher in visual quality than results from existing techniques used in today's video cameras (*i.e., see Col. 2, line 33 to Col. 6, line 59*).

Therefore, it would have been obvious at the time the invention was made to one of ordinary skill in the art to modify the Ishii device by incorporating method as taught by Newman so as to would have options using method effecting RAW Bayer compression and performing de-Bayer filtering during a real time review during editing or post production, thereby enhancing the image quality.

With regard to claim 2, Ishii in view of Newman discloses all basic limitations as discussed in claim 1. Ishii and Newman, in combination, further discloses the image sensor is configured to output the raw mosaiced image data at a resolution of at least 2k and at a frame rate of at least 23 frames per second, wherein the compressed processed image data can be decompressed and demosaiced into a visually lossless image (*i.e., compression can be lossless, see Newman, Col. 6, lines 37-44*) of at least 2k resolution, and wherein the memory device (109a – 109d) receives the compressed processed image data at a rate of at least 23 frames per second (*i.e. see the rejection(s) of claim 16 as discussed above*).

With regard to claim 3, Ishii in view of Newman discloses all basic limitations as discussed in claim 1. Ishii and Newman, in combination, further discloses the image sensor is configured to output the raw mosaiced image data at a resolution of at least 4k, and the compressed processed image data can be decompressed and demosaiced into a substantially visually lossless image (*i.e., compression can be lossless, see Newman, Col. 6, lines 37-44*) of at least 4k resolution (*i.e., see Ishii, figure 2, Col. 5, lines 50 -64 and also see the rejection(s) of claim 16 as discussed above*).

With regard to claim 4, Ishii in view of Newman discloses all basic limitations as discussed in claim 1. Ishii and Newman, in combination, further discloses the image sensor is configured to output the raw mosaiced image data at a resolution of at least 4k and at a frame rate of at least 23 frames per second, wherein the compressed processed image data can be decompressed and demosaiced into a visually lossless image of at least 4k resolution, and wherein the memory device (*i.e., recording units 109a – 109d*) receives the compressed processed image data at a rate of at least 23 frames per second (*i.e., see Ishii, figure 2, Col. 5, lines 50 -64 and also see the rejection(s) of claim 16 as discussed above*).

With regard to claim 5, Ishii in view of Newman discloses all basic limitations as discussed in claim 1. Ishii further discloses the one data value for each of the first plurality of light sensitive devices is representative of light of only the first color, the one data value for each of the second plurality of light sensitive devices is representative of

Art Unit: 2664

light of only the second color, and the one data value for each of the third plurality of light sensitive devices is representative of only the third color (*i.e.*, Bayer-arranged RGB sensor), and wherein the processed image data does not include separate data values for the first, second, and third colors for each of the light sensitive devices (*i.e.*, see figure 2, Col. 5, line 45 to Col. 6, line 3).

With regard to claim 6, Ishii in view of Newman discloses all basic limitations as discussed in claim 1. Ishii further discloses the memory device is disposed within the portable housing (*i.e.*, see figure 24, Col.21, line 35 to Col. 22, line 30).

With regard to claim 7, Ishii in view of Newman discloses all basic limitations as discussed in claim 1. Ishii further discloses the memory device is supported on the outside of the portable housing (*i.e.*, external memory device inherently included, see figure 25).

With regard to claim 8, Ishii in view of Newman discloses all basic limitations as discussed in claim 1. Ishii further discloses a playback module (*i.e.*, display unit 115) configured to receive the compressed processed image data from the memory device, and decompress and demosaic the compressed processed image data into demosaiced image data that includes three data values for each of the light sensitive devices included in the first, second, and third pluralities of light sensitive devices (*i.e.*, see figure 24, Col. 21, lines 15-53).

Art Unit: 2664

With regard to claim 9, Ishii in view of Newman discloses all basic limitations as discussed in claim 1, **except** the compression module comprises a compression chip. *However, an ordinary skilled in the art would have obviously known this design by packing the compression units into an integrated circuit (IC) for saving space in the camera, thereby enabling the image pickup device being much more compact.*

With regard to claim 10, Ishii in view of Newman discloses all basic limitations as discussed in claim 1. Newman further the compression technique is a wavelet compression technique (*i.e., see Col. 6, lines 37-50*).

With regard to claim 11, Ishii in view of Newman discloses all basic limitations as discussed in claim 1. Ishii further discloses the image processing module is configured to process the raw mosaiced image data at least in part by applying a pre-emphasis function (*i.e., predetermined image process*) to the raw mosaiced image data, wherein the pre-emphasis function is configured to increase data values of the mosaiced image data corresponding to relatively dark image regions and to decrease data values of the mosaiced image data corresponding to relatively bright image regions (*i.e., see Col. 5, lines 30-49*).

With regard to claim 12, Ishii in view of Newman discloses all basic limitations as discussed in claim 1. Ishii and Newman, in combination, further discloses the image

Art Unit: 2664

sensor is configured to output the raw mosaiced image data at a resolution falling within a range between and inclusive of 2k and 4.5k and at a frame rate falling within a range between and inclusive of 23 and 120 frames per second, wherein the compression module is configured to compress the processed image data with a mathematically lossy compression technique into compressed processed image data such that the compressed processed image data can be decompressed and demosaiced into a substantially visually lossless image having a resolution falling within a range between and inclusive of 2k and 4.5k resolution, and wherein the memory device receives the compressed processed image data at a rate falling within a range between and inclusive of 23 frames per second and 120 frames per second (*i.e.*, see figure 2, Col. 5, line 50 to Col. 7, line 17).

With regard to claim 13, Ishii in view of Newman discloses all basic limitations as discussed in claim 1. Ishii and Newman, in combination, further discloses the image sensor is configured to output the raw mosaiced image data at a resolution that is one of 2k, 4k, and 4.5k and at a frame rate falling within a range between and inclusive of 23 and 120 frames per second, wherein the compression module is configured to compress the processed image data with a mathematically lossy compression technique into compressed processed image data such that the compressed processed image data can be decompressed and demosaiced into a substantially visually lossless image having a resolution that is one of 2k, 4k, and 4.5k, and wherein the memory device receives the compressed processed image data at a rate falling within a range

Art Unit: 2664

between and inclusive of 23 frames per second and 120 frames per second (*i.e.*, see *figure 2, Col. 5, line 50 to Col. 7, line 17*).

With regard to claim 14, Ishii in view of Newman discloses all basic limitations as discussed in claim 1, **except** the memory device is sufficiently large to store image data from the compression module corresponding to at least about 30 minutes of video at 12 mega pixel resolution, 12-bit color resolution, and at 60 frames per second *However, an ordinary skilled in the art would have obviously known that an external recording device, directly connectable to the image pickup device, would be used to store image data from the compression module corresponding to at least about 30 minutes of video at 12 mega pixel resolution, 12-bit color resolution, and at 60 frames per second, thereby allowing the operator continuously records the desired scene without interruption..*

With regard to claim 15, Ishii in view of Newman discloses all basic limitations as discussed in claim 1. Ishii further discloses the image sensor is a CMOS sensor (*i.e.*, *CMOS sensor, Bayer arranged, see figure 2, Col.5, lines 50-67*).

As to claim 16, *Ishii discloses in figures 1-24, a method of recording motion video with a camera (i.e., image pickup device and image recording apparatus for recording moving image data, see abstract, Col. 4, line 44 to Col. 6, line 38 and Col. 17, line 24 to Col. 22, line 41), the method comprising:*

Art Unit: 2664

receiving light with an image sensor (103) of a camera (*i.e.*, *image pickup device*), the image sensor comprising first, second, and third pluralities of light sensitive devices arranged with respect to one another in a plane defined by the image sensor such that the first, second, and third pluralities of light sensitive devices are intermingled, defining an intermingled pattern, the first, second, and third pluralities of light sensitive devices being configured to detect first, second, and third colors, respectively, the first, second, and third colors being different from each other (*RGB sensor*) (*i.e.*, *Bayer-arranged sensor*, see figure 2, Col. 5, line 50 to Col. 6, line3);

converting the light received by the image sensor (104) into mosaiced image data (*i.e.*, *performing Bayer interpolation and color correction*) at a resolution of at least 2k and at a frame rate of at least about 23 frames per second, the mosaiced image data comprising one data value for each of the light sensitive devices included in the first, second, and third pluralities of light sensitive devices (*i.e.*, *4K image pickup mode at 60 fps*, see figures 2-4, Col.5, line 50 to Col. 7, line 17);

with electronics of the camera, processing (104) the mosaiced image data from the image sensor (103) and outputting processed image data based on the mosaiced image data from the image sensor (*i.e.*, *interpolation and color correction*); the processed image data including less than three data values for each of the light sensitive devices (*RGB photodiodes*) included in the first, second, and third pluralities of light sensitive devices (*i.e.*, *Bayer-arranged sensor*, see figure 2, Col. 5, line 50 to Col. 6, line3);

Art Unit: 2664

with electronics of the camera, compressing (112a – 112d) the processed image data with a mathematically lossy compression technique into compressed processed image data such that the compressed processed image data can be decompressed (113a – 113d) into a substantially visually lossless image of at least 2k resolution; and recording (109a - 109d) the compressed processed image data onto a memory device of the camera at a rate of at least about 23 frames per second (*i.e.*, see Col.22, lines 15-41).

Ishii **is silent** as the image demosaiced processing.

However, *Newman teaches in figures 1-8*, relates to an invention allows for video images from Bayer-style cameras to be processed in high resolution far more efficiently than the current state of the art. The interleaved color components within a Bayer sensor are typically arranged in 2.times.2 pixel squares over the entire image with red and green on the top pair, and green and blue on the bottom of each 2.times.2 pixel array. This pattern of interleaved red, green and blue pixels is problematic for compression as a single image because the spatially-adjacent pixels are much less correlated and therefore less compressible than a plane of monochrome data. Compression operates most effectively when adjacent pixels have a high likelihood of being similar, yet in a Bayer image the adjacent pixels are filtered for different color primaries, so pixel magnitudes will vary greatly. Attempting direct compression of a Bayer image using common techniques such as DCT or wavelet compression will either result in little or no reduction of data size, or a significant amount of image distortion. This invention allows higher compression without introducing visually-damaging

Art Unit: 2664

distortion of the image, using existing compression technologies like DCT and wavelet. Newman further discloses the de-Bayer filtering (or demosaiicing) is the process of interpolating the missing color components at every pixel location. As acquired, the Bayer sensor only collects one of the three color primaries at every pixel site--the two other primaries are predicted via a range of different algorithms that typically take substantial compute time for high quality results. In the above 1920.times.1080 encoding example, the compressed video image produced will be smaller in data size yet higher in visual quality than results from existing techniques used in today's video cameras (*i.e., see Col. 4, line5 to Col. 6, line 59*).

Therefore, it would have been obvious at the time the invention was made to one of ordinary skill in the art to modify the Ishii device by incorporating method as taught by Newman so as to would have options for performing the de-Bayer filtering during a real time review during editing or post production, thereby enhancing the image quality.

With regard to claim 17, Ishii in view of Newman discloses all basic limitations as discussed in claim 16. Ishii and Newman, in combination, further discloses converting the light received by the image sensor into mosaiced image data at a resolution of at least 2k and at a frame rate of at least 23 frames per second, wherein the compressed processed image data can be decompressed and demosaiced into a visually lossless (*i.e., compression can be lossless, see Newman, Col. 6, lines 37-44*) image of at least 2k resolution, and wherein said recording comprises recording the compressed

Art Unit: 2664

processed image data onto a memory device (109a – 109d) of the camera at a rate of at least 23 frames per second (*i.e. see the rejection(s) of claim 16 as discussed above*).

With regard to claim 18, Ishii in view of Newman discloses all basic limitations as discussed in claim 16. Ishii and Newman, in combination, further discloses converting the light received by the image sensor into mosaiced image data at a resolution of at least 4k, and the compressed processed image data can be decompressed and demosaiced into a substantially visually lossless image (*i.e., compression can be lossless, see Newman, Col. 6, lines 37-44*) of at least 4k resolution (*i.e., see Ishii, figure 2, Col. 5, lines 50 -64 and also see the rejection(s) of claim 16 as discussed above*).

With regard to claim 19, Ishii in view of Newman discloses all basic limitations as discussed in claim 16. Ishii and Newman, in combination, further discloses converting the light received by the image sensor into mosaiced image data at a resolution of at least 4k and at a frame rate of at least 23 frames per second, wherein the compressed processed image data can be decompressed and demosaiced into a visually lossless image of at least 4k resolution, and wherein said recording comprises recording the compressed processed image data onto a memory device (*i.e., recording units 109a – 109d*) of the camera at a rate of at least 23 frames per second (*i.e., see Ishii, figure 2, Col. 5, lines 50 -64 and also see the rejection(s) of claim 16 as discussed above*).

With regard to claim 20, Ishii in view of Newman discloses all basic limitations as discussed in claim 16. Ishii further discloses the one data value for each of the first plurality of light sensitive devices is representative of light of only the first color, the one data value for each of the second plurality of light sensitive devices is representative of light of only the second color, and the one data value for each of the third plurality of light sensitive devices is representative of only the third color (*i.e., Bayer-arranged RGB sensor*), and wherein the processed image data (*i.e., interpolated data*) does not include separate data values for the first, second, and third colors for each of the light sensitive devices (*i.e., see figure 2, Col. 5, line 45 to Col. 6, line 3*).

With regard to claim 21, Ishii in view of Newman discloses all basic limitations as discussed in claim 16. Ishii further discloses recording the compressed processed image data onto a memory device disposed within a portable housing of the camera (*i.e., see Col. 22, lines 15 - 41*).

With regard to claim 22, Ishii in view of Newman discloses all basic limitations as discussed in claim 16. Ishii further discloses recording the compressed processed image data onto a memory device supported on the outside of a portable housing of the camera (*i.e., external memory device inherently included, see figure 25*).

With regard to claim 23, Ishii in view of Newman discloses all basic limitations as discussed in claim 16. Ishii further discloses receiving (*i.e., display unit 115*) the

Art Unit: 2664

compressed processed image data from the memory device with a playback module implemented in the electronics of the camera; and decompressing and demosaicing the compressed processed image data into demosaiced image data that includes three data values for each of the light sensitive devices included in the first, second, and third pluralities of light sensitive devices (*i.e.*, see figure 24, Col. 21, lines 15-53).

With regard to claim 24, Ishii in view of Newman discloses all basic limitations as discussed in claim 16, **except** the electronics comprise a compression chip and said compressing is done using the compression chip. *However, an ordinary skilled in the art would have obviously known this design by packing the compression units into an integrated circuit (IC) for saving space in the camera, thereby enabling the image pickup device being much more compact.*

With regard to claim 25, Ishii in view of Newman discloses all basic limitations as discussed in claim 16. Newman further discloses the mosaiced image data is raw mosaiced image data (*i.e.*, see Col. 2, lines 43-51 and Col. 6, Lines 25-59).

With regard to claim 26, Ishii in view of Newman discloses all basic limitations as discussed in claim 16. Newman further discloses the compression technique is a wavelet compression technique (*i.e.*, see Col. 6, lines 37-50).

With regard to claim 27, Ishii in view of Newman discloses all basic limitations as discussed in claim 16. Ishii further discloses processing the image data comprises processing the mosaiced image data at least in part by applying a pre-emphasis function to the mosaiced image data (*i.e., predetermined image process*), wherein the application of the pre-emphasis function increases data values of the mosaiced image data corresponding to relatively dark image regions and decreases data values of the mosaiced image data corresponding to relatively bright image regions (*i.e., see Col. 5, lines 30-49*).

With regard to claim 28, Ishii in view of Newman discloses all basic limitations as discussed in claim 16. Ishii and Newman, in combination, further discloses converting the light received by the image sensor into mosaiced image data at a resolution falling within a range between and inclusive of 2k and 4.5k and at a frame rate falling within a range between and inclusive of 23 and 120 frames per second, wherein said compressing comprises compressing the processed image data with a mathematically lossy compression technique into compressed processed image data such that the compressed processed image data can be decompressed and demosaiced into a substantially visually lossless image having a resolution falling within a range between and inclusive of 2k and 4.5k resolution, and said recording comprises recording the compressed processed image data at a rate falling within a range between and inclusive of 23 frames per second and 120 frames per second (*i.e., see figure 2, Col. 5, line 50 to Col. 7, line 17*).

With regard to claim 29, Ishii in view of Newman discloses all basic limitations as discussed in claim 16. Ishii and Newman, in combination, further discloses converting the light received by the image sensor into mosaiced image data at a resolution that is one of 2k, 4k, and 4.5k and at a frame rate falling within a range between and inclusive of 23 and 120 frames per second, wherein said compressing comprises compressing the processed image data with a mathematically lossy compression technique into compressed processed image data such that the compressed processed image data can be decompressed and demosaiced into a substantially visually lossless image having a resolution that is one of 2k, 4k, and 4.5k, and said recording comprises recording the compressed processed image data at a rate falling within a range between and inclusive of 23 frames per second and 120 frames per second (*i.e.*, see *figure 2, Col. 5, line 50 to Col. 7, line 17*).

With regard to claim 30, Ishii in view of Newman discloses all basic limitations as discussed in claim 16, **except** the memory device is sufficiently large to store image data from the compression module corresponding to at least about 30 minutes of video at 12 mega pixel resolution, 12-bit color resolution, and at 60 frames per second. *However, an ordinary skilled in the art would have obviously known that an external recording device, directly connectable to the image pickup device, would be used to store image data from the compression module corresponding to at least about 30 minutes of video at 12 mega pixel resolution, 12-bit color resolution, and at 60 frames*

Art Unit: 2664

per second, thereby allowing the operator continuously recording the desired scene without interruption.

Conclusion

Any inquiry concerning this communication or earlier communications from the examiner should be directed to TRUNG DIEP whose telephone number is (571)270-5088. The examiner can normally be reached on Mon.,- Thur., 8:00 am,-5:00 p.m. EST.

If attempts to reach the examiner by telephone are unsuccessful, the examiner's supervisor, Lin Ye can be reached on (571) 272-7372. The fax phone number for the organization where this application or proceeding is assigned is 571-273-8300.

Information regarding the status of an application may be obtained from the Patent Application Information Retrieval (PAIR) system. Status information for published applications may be obtained from either Private PAIR or Public PAIR. Status information for unpublished applications is available through Private PAIR only. For more information about the PAIR system, see <http://pair-direct.uspto.gov>. Should you have questions on access to the Private PAIR system, contact the Electronic Business Center (EBC) at 866-217-9197 (toll-free). If you would like assistance from a USPTO Customer Service Representative or access to the automated information system, call 800-786-9199 (IN USA OR CANADA) or 571-272-1000.

/TRUNG DIEP/
Primary Examiner, Art Unit 2664

Notice of References Cited	Application/Control No. 14/485,612	Applicant(s)/Patent Under Reexamination JANNARD ET AL.	
	Examiner TRUNG DIEP	Art Unit 2664	Page 1 of 1

U.S. PATENT DOCUMENTS

*	Document Number Country Code-Number-Kind Code	Date MM-YYYY	Name	Classification
*	A US-7,898,575 B2	03-2011	Ishii, Kensuke	348/222.1
B	US-			
C	US-			
D	US-			
E	US-			
F	US-			
G	US-			
H	US-			
I	US-			
J	US-			
K	US-			
L	US-			
M	US-			

FOREIGN PATENT DOCUMENTS

*	Document Number Country Code-Number-Kind Code	Date MM-YYYY	Country	Name	Classification
N					
O					
P					
Q					
R					
S					
T					

NON-PATENT DOCUMENTS

*	Document Number Country Code-Number-Kind Code	Date MM-YYYY	Country	Name	Classification
*	Include as applicable: Author, Title Date, Publisher, Edition or Volume, Pertinent Pages)				
U					
V					
W					
X					

*A copy of this reference is not being furnished with this Office action. (See MPEP § 707.05(a).)
Dates in MM-YYYY format are publication dates. Classifications may be US or foreign.

Search Notes 	Application/Control No. 14485612	Applicant(s)/Patent Under Reexamination JANNARD ET AL.
	Examiner TRUNG DIEP	Art Unit 2664

CPC- SEARCHED		
Symbol	Date	Examiner
(G08B13/19628 OR H04N9/43 OR G06T7/2006 OR H04N9/045 OR H04N2209/046 OR H04N5/23235 OR H04N13/0257 OR G06T3/4015 OR G06T9/007 OR H04N19/00315 OR H04N19/00763 OR H04N19/00903 OR H04N1/648 OR H04N5/225	11/10/2014	TD

CPC COMBINATION SETS - SEARCHED		
Symbol	Date	Examiner

US CLASSIFICATION SEARCHED			
Class	Subclass	Date	Examiner
348	240.2, 222.1, 223.1, 273-280.	11/10/2014	TD
375	240.2, 240.25, 240.26 and 340.29.	11/10/2014	TD
382	166-167.	11/10/2014	TD

SEARCH NOTES		
Search Notes	Date	Examiner
EAST searched.	11/10/2014	TD
Combined text with US subclasses searched.	11/10/2014	TD
Combined text with US subgroups searched.	11/10/2014	TD

INTERFERENCE SEARCH			
US Class/ CPC Symbol	US Subclass / CPC Group	Date	Examiner

--	--

EAST Search History

EAST Search History (Prior Art)

Ref #	Hits	Search Query	DBs	Default Operator	Plurals	Time Stamp
S1	0	"14485612"	US-PGPUB; USPAT; USOCR; FPRS; EPO; JPO; DERWENT; IBM_TDB	OR	ON	2014/11/06 10:16
S2	13023	((348/222.1) or (348/223.1) or (348/273-280)).ccls.	US-PGPUB; USPAT; USOCR; FPRS; EPO; JPO; DERWENT; IBM_TDB	OR	ON	2014/11/08 18:02
S3	8316	382/166-167.ccls.	US-PGPUB; USPAT; USOCR; FPRS; EPO; JPO; DERWENT; IBM_TDB	OR	ON	2014/11/08 18:03
S4	20655	S2 or S3	US-PGPUB; USPAT; USOCR; FPRS; EPO; JPO; DERWENT; IBM_TDB	OR	ON	2014/11/08 18:05
S5	48080	(video or motio\$3 or mov\$3 near2 imag\$3) and (compress\$3 raw adj data) and (movie or cinema adj camera)	US-PGPUB; USPAT; USOCR; FPRS; EPO; JPO; DERWENT; IBM_TDB	OR	ON	2014/11/08 18:07
S6	563	S4 and S5	US-PGPUB; USPAT; USOCR; FPRS; EPO; JPO; DERWENT; IBM_TDB	OR	ON	2014/11/08 18:08
S7	99	S6 and (mosaic\$3 or interpolat\$3 adj imag\$3)	US-PGPUB; USPAT; USOCR; FPRS; EPO; JPO; DERWENT; IBM_TDB	OR	ON	2014/11/08 18:08
S8	23	S6 and (2K or 4K adj camera)	US-PGPUB;	OR	ON	2014/11/08

			USPAT; USOCR; FPRS; EPO; JPO; DERWENT; IBM_TDB			18:10
S10	9585	"348"/\$.cls. and S9	US-PGPUB; USPAT; USOCR; FPRS; EPO; JPO; DERWENT; IBM_TDB	OR	ON	2014/11/08 21:36
S11	772	S10 and (mosaic\$3 or interpolat\$3 adj imag\$3)	US-PGPUB; USPAT; USOCR; FPRS; EPO; JPO; DERWENT; IBM_TDB	OR	ON	2014/11/08 21:36
S12	25	S11 and (2K or 4K adj camera)	US-PGPUB; USPAT; USOCR; FPRS; EPO; JPO; DERWENT; IBM_TDB	OR	ON	2014/11/08 21:36
S13	21	S12 AND ((G08B13/19628 OR H04N9/43 OR G06T7/2006 OR H04N9/045 OR H04N2209/046 OR H04N5/23235 OR H04N13/0257 OR G06T3/4015 OR G06T9/007 OR H04N19/00315 OR H04N19/00763 OR H04N19/00903 OR H04N1/648 OR H04N5/225 OR H04N7/0127).CPC.)	US-PGPUB; USPAT; USOCR; FPRS; EPO; JPO; DERWENT; IBM_TDB	OR	ON	2014/11/08 21:59
S14	13023	((348/222.1) or (348/223.1) or (348/273-280)).cls.	US-PGPUB; USPAT; USOCR; FPRS; EPO; JPO; DERWENT; IBM_TDB	OR	ON	2014/11/08 22:02
S15	8316	382/166-167.cls.	US-PGPUB; USPAT; USOCR; FPRS; EPO; JPO; DERWENT; IBM_TDB	OR	ON	2014/11/08 22:02
S16	20655	S14 or S15	US-PGPUB; USPAT; USOCR; FPRS; EPO; JPO; DERWENT; IBM_TDB	OR	ON	2014/11/08 22:02
S17	563	S16 and S9	US-PGPUB; USPAT; USOCR; FPRS; EPO; JPO;	OR	ON	2014/11/08 22:02

			DERWENT; IBM_TDB			
S18	23	S17 and (2K or 4K adj camera)	US-PGPUB; USPAT; USOCR; FPRS; EPO; JPO; DERWENT; IBM_TDB	OR	ON	2014/11/08 22:02
S19	10	S18 AND ((G08B13/19628 OR H04N9/43 OR G06T7/2006 OR H04N9/045 OR H04N2209/046 OR H04N5/23235 OR H04N13/0257 OR G06T3/4015 OR G06T9/007 OR H04N19/00315 OR H04N19/00763 OR H04N19/00903 OR H04N1/648 OR H04N5/225 OR H04N7/0127).CPC.)	US-PGPUB; USPAT; USOCR; FPRS; EPO; JPO; DERWENT; IBM_TDB	OR	ON	2014/11/08 22:02
S20	2	"8477173".pn.	US-PGPUB; USPAT; USOCR; FPRS; EPO; JPO; DERWENT; IBM_TDB	OR	ON	2014/11/08 22:03
S21	3	"8014597".pn.	US-PGPUB; USPAT; USOCR; FPRS; EPO; JPO; DERWENT; IBM_TDB	OR	ON	2014/11/08 22:04
S22	2	"6198505".pn.	US-PGPUB; USPAT; USOCR; FPRS; EPO; JPO; DERWENT; IBM_TDB	OR	ON	2014/11/09 11:13
S23	3	"7898575".pn.	US-PGPUB; USPAT; USOCR; FPRS; EPO; JPO; DERWENT; IBM_TDB	OR	ON	2014/11/09 11:19
S24	1	"7898575".pn. and (interpolat\$3 or demosaic\$3)	US-PGPUB; USPAT; USOCR; FPRS; EPO; JPO; DERWENT; IBM_TDB	OR	ON	2014/11/09 11:20
S25	1	S22 and (interpolat\$3 or demosaic\$3)	US-PGPUB; USPAT; USOCR; FPRS; EPO; JPO; DERWENT; IBM_TDB	OR	ON	2014/11/09 11:22
S26	1	S22 and (interpolat\$3 or mosaic\$3)	US-PGPUB; USPAT;	OR	ON	2014/11/09 11:23

			USOCR; FPRS; EPO; JPO; DERWENT; IBM_TDB			
S27	0	S22 and (decompress\$3 or demosaic\$3)	US-PGPUB; USPAT; USOCR; FPRS; EPO; JPO; DERWENT; IBM_TDB	OR	ON	2014/11/09 11:24
S28	2	S23 and (decompress\$3 or demosaic\$3)	US-PGPUB; USPAT; USOCR; FPRS; EPO; JPO; DERWENT; IBM_TDB	OR	ON	2014/11/09 11:24
S29	1307	((348/224) or 382/232) or (386/224)).ccls.	US-PGPUB; USPAT; USOCR; FPRS; EPO; JPO; DERWENT; IBM_TDB	OR	ON	2014/11/09 13:06
S30	13023	((348/222.1) or (348/223.1) or (348/273-280)).ccls.	US-PGPUB; USPAT; USOCR; FPRS; EPO; JPO; DERWENT; IBM_TDB	OR	ON	2014/11/09 13:06
S31	8316	382/166-167.ccls.	US-PGPUB; USPAT; USOCR; FPRS; EPO; JPO; DERWENT; IBM_TDB	OR	ON	2014/11/09 13:06
S32	20655	S30 or S31	US-PGPUB; USPAT; USOCR; FPRS; EPO; JPO; DERWENT; IBM_TDB	OR	ON	2014/11/09 13:06
S33	21927	S29 or S32	US-PGPUB; USPAT; USOCR; FPRS; EPO; JPO; DERWENT; IBM_TDB	OR	ON	2014/11/09 13:06
S34	48080	(video or motio\$3 or mov\$3 near2 imag\$3) and (compress\$3 raw adj data) and (movie or cinema adj camera)	US-PGPUB; USPAT; USOCR; FPRS; EPO; JPO; DERWENT; IBM_TDB	OR	ON	2014/11/09 13:07

S35	657	S33 and S34	US-PGPUB; USPAT; USOCR; FPRS; EPO; JPO; DERWENT; IBM_TDB	OR	ON	2014/11/09 13:07
S36	26	S35 and (2K or 4K adj camera)	US-PGPUB; USPAT; USOCR; FPRS; EPO; JPO; DERWENT; IBM_TDB	OR	ON	2014/11/09 13:08
S37	102	S35 and (mosaic\$3 or interpolat\$3 adj imag\$3)	US-PGPUB; USPAT; USOCR; FPRS; EPO; JPO; DERWENT; IBM_TDB	OR	ON	2014/11/09 13:19
S38	3	"8014597".pn.	US-PGPUB; USPAT; USOCR; FPRS; EPO; JPO; DERWENT; IBM_TDB	OR	ON	2014/11/09 17:28
S39	1	S38 and (decompress\$3 or demosaic\$3)	US-PGPUB; USPAT; USOCR; FPRS; EPO; JPO; DERWENT; IBM_TDB	OR	ON	2014/11/09 17:28
S40	1	S38 and (RAW or raw adj data)	US-PGPUB; USPAT; USOCR; FPRS; EPO; JPO; DERWENT; IBM_TDB	OR	ON	2014/11/09 18:13
S41	0	"7898575".pn. and (RAW or raw adj data)	US-PGPUB; USPAT; USOCR; FPRS; EPO; JPO; DERWENT; IBM_TDB	OR	ON	2014/11/09 18:14
S42	1	"7898575".pn. and (compress\$3 or decompress\$3 adj data)	US-PGPUB; USPAT; USOCR; FPRS; EPO; JPO; DERWENT; IBM_TDB	OR	ON	2014/11/09 18:17
S43	0	"7898575".pn. and (de-interpolat\$3 or demosaic\$3)	US-PGPUB; USPAT; USOCR; FPRS; EPO; JPO;	OR	ON	2014/11/09 18:28

			DERWENT; IBM_TDB			
--	--	--	---------------------	--	--	--

11/ 10/ 2014 12:56:59 PM

C:\Users\tdiep\Documents\EAST\Workspaces\14485612.wsp

INFORMATION DISCLOSURE STATEMENT

Inventor : James H. Jannard
 App. No. : 14/485612
 Filed : September 12, 2014
 For : VIDEO CAMERA
 Examiner : Unknown
 Art Unit : 2661
 Conf. No. : 1068

11/10/2014

/Trung Diep/

Commissioner for Patents
 P.O. Box 1450
 Alexandria, VA 22313-1450

References and Listing

Submitted herewith in the above-identified application is an Information Disclosure Statement listing references for consideration. Listed foreign and non-patent literature references corresponding to reference numbers 169-189 and 192-299 are of record in U.S. patent application No. 13/464803, filed May 4, 2012, which is relied upon for an earlier filing date under 35 USC 120. Copies of the references are not submitted pursuant to 37 CFR 1.98(d). However, Applicant would be happy to provide references upon request.

For certain cited non-English patent and/or non-patent references, machine translations of the references (and/or Abstracts) are included, and inclusion is indicated in the last column. Applicant makes no representation as to the accuracy of the English machine translations. If the Examiner would like additional information regarding these references or if anything is unclear, the Examiner is invited to request such information, and Applicant will attempt to comply with any such request.

Applicant wishes to draw the Examiner's attention to the following applications owned by of the present application's assignee:

Docket No.	Serial No.	Patent/ Publication No.	Title	Filed
REDCOM.007A	12/101,882	8,174,560	VIDEO CAMERA	04/11/2008
REDCOM.007C1	13/464,803	2012/0294582	VIDEO CAMERA	05/04/2012
REDCOM.007C2	13/566,868	8,358,357	VIDEO CAMERA	08/03/2012
REDCOM.007C3	14/485,611	N/A	VIDEO CAMERA	09/12/2014
REDCOM.007CP1	12/422,507	8,237,830	VIDEO CAMERA	04/13/2009
REDCOM.007CP1C1	12/834,854	7,830,967	VIDEO CAMERA	07/12/2010

Application No.: 14/485612
Filing Date: September 12, 2014

Docket No.	Serial No.	Patent/ Publication No.	Title	Filed
REDCOM.007CP1C2	13/566,924	2013/0113951	VIDEO CAMERA	08/03/2012
REDCOM.007P1C3	14/488,030	N/A	VIDEO CAMERA	09/16/2014
REDCOM.007X1 (reexamination of REDCOM.007A)	90/012,550	8,174,560 C1	VIDEO CAMERA	09/13/2012

Applicant notes that cited references, office actions, responses and notices of allowance currently exist or will exist for the above-referenced matters. Applicant also understands that the Examiner has access to sophisticated online Patent Office computing systems that provide ready access to the full file histories of these matters including, for example, specifications, drawings, pending claims, cited art, office actions, responses, declarations, and notices of allowance. Rather than submit copies these file histories, Applicant respectfully requests that the Examiner continue to review these file histories online for past, current, and future information about these matters. Also, if the Examiner cannot readily access these file histories, the Applicant would be pleased to provide any portion of any of the file histories at any time upon specific Examiner request.

The present application relies on co-owned U.S. Patent Application Serial No. 12/101,882 for an earlier filing date under 35 USC 120. U.S. Patent No. 8,174,560 issued from the '882 application, and U.S. Patent No. 8,358,357 relies on the '882 application for an earlier filing date under 35 U.S.C. § 120.

Out of an abundance of caution, Applicant wishes to make the Examiner aware that the '560 patent and the '357 patent were involved in the following proceeding, which was subsequently dismissed and is no longer pending: *RED.COM, INC., Inc. v. Sony Corporation of America and Sony Electronics, Inc.*, U.S. District Court for the Southern District of California, Case No.: 3:13-cv-00334-DMS-BGS. The complaint is being submitted herewith, corresponding to reference number 241.

In addition, the listed references include a number of on-line discussion threads (including those corresponding to reference numbers 243-269) posted on two websites: www.dvxuser.com and www.hdforindies.com ("the Websites"). Each discussion thread generally consists of a chronological string of individual posts, made by various authors at different times. The Websites noted above also contain other threads, are believed to be presently operational, and are full-text searchable.

Pursuant to 37 C.F.R § 1.97(g) and (h), Applicants make no representation that the information is considered to be material to patentability. Additionally, inclusion on this list is not an admission that any of the cited documents are prior art in this application. Further, Applicants make no representation regarding the completeness of this list, or that better art does not exist.

Application No.: 14/485612
Filing Date: September 12, 2014

Timing of Disclosure

This Information Disclosure Statement is being filed within three months of the filing date or date of national phase entry, with an RCE or before receipt of a First Office Action after an RCE, and no fee is required.

The Commissioner is hereby authorized to charge any additional fees which may be required, or credit any overpayment, to Account No. 11-1410.

Respectfully submitted,
KNOBBE, MARTENS, OLSON & BEAR, LLP

Dated: October 7, 2014

By: /Sean Ambrosius/ _____
Sean Ambrosius
Registration No. 65,290
Attorney of Record
Customer No. 20995
(949) 760-0404

18876909

UNITED STATES PATENT AND TRADEMARK OFFICE

UNITED STATES DEPARTMENT OF COMMERCE
United States Patent and Trademark Office
 Address: COMMISSIONER FOR PATENTS
 P.O. Box 1450
 Alexandria, Virginia 22313-1450
 www.uspto.gov

BIB DATA SHEET
CONFIRMATION NO. 1068

SERIAL NUMBER	FILING or 371(c) DATE	CLASS	GROUP ART UNIT	ATTORNEY DOCKET NO.		
14/485,612	09/12/2014	348	2664	REDCOM.007C4		
APPLICANTS RED.COM, INC., Irvine, CA, Assignee (with 37 CFR 1.172 Interest);						
INVENTORS James H. Jannard, Las Vegas, NV; Thomas Graeme Nattress, Acton, CANADA;						
** CONTINUING DATA ***** This application is a CON of 13/464,803 05/04/2012 PAT 8872933 which is a CON of 12/101,882 04/11/2008 PAT 8174560 which claims benefit of 60/911,196 04/11/2007 and claims benefit of 61/017,406 12/28/2007						
** FOREIGN APPLICATIONS *****						
** IF REQUIRED, FOREIGN FILING LICENSE GRANTED ** 09/18/2014						
Foreign Priority claimed 35 USC 119(a-d) conditions met Verified and Acknowledged	<input type="checkbox"/> Yes <input checked="" type="checkbox"/> No <input type="checkbox"/> Yes <input checked="" type="checkbox"/> No /TRUNG T DIEP/ Examiner's Signature	<input type="checkbox"/> Met after Allowance Initials	STATE OR COUNTRY NV	SHEETS DRAWINGS 18	TOTAL CLAIMS 30	INDEPENDENT CLAIMS 2
ADDRESS KNOBBE MARTENS OLSON & BEAR LLP 2040 MAIN STREET FOURTEENTH FLOOR IRVINE, CA 92614 UNITED STATES						
TITLE VIDEO CAMERA						
FILING FEE RECEIVED 2540	FEES: Authority has been given in Paper No. _____ to charge/credit DEPOSIT ACCOUNT No. _____ for following:		<input type="checkbox"/> All Fees <input type="checkbox"/> 1.16 Fees (Filing) <input type="checkbox"/> 1.17 Fees (Processing Ext. of time) <input type="checkbox"/> 1.18 Fees (Issue) <input type="checkbox"/> Other _____ <input type="checkbox"/> Credit			

Index of Claims 	Application/Control No. 14485612	Applicant(s)/Patent Under Reexamination JANNARD ET AL.
	Examiner TRUNG DIEP	Art Unit 2664

✓	Rejected
=	Allowed

-	Cancelled
÷	Restricted

N	Non-Elected
I	Interference

A	Appeal
O	Objected

Claims renumbered in the same order as presented by applicant
 CPA
 T.D.
 R.1.47

CLAIM		DATE							
Final	Original	11/10/2014							
	1	✓							
	2	✓							
	3	✓							
	4	✓							
	5	✓							
	6	✓							
	7	✓							
	8	✓							
	9	✓							
	10	✓							
	11	✓							
	12	✓							
	13	✓							
	14	✓							
	15	✓							
	16	✓							
	17	✓							
	18	✓							
	19	✓							
	20	✓							
	21	✓							
	22	✓							
	23	✓							
	24	✓							
	25	✓							
	26	✓							
	27	✓							
	28	✓							
	29	✓							
	30	✓							

INFORMATION DISCLOSURE STATEMENT BY APPLICANT	Application No.	14/485612
	Filing Date	September 12, 2014
	First Named Inventor	James H. Jannard
	Art Unit	2661 2664
<i>(Multiple sheets used when necessary)</i>	Examiner	Sharon T. Diep
SHEET 1 OF 14	Attorney Docket No.	REDCOM.007C4

U.S. PATENT DOCUMENTS					
Examiner Initials	Cite No.	Document Number <i>Number - Kind Code (if known)</i> Example: 1,234,567 B1	Publication Date MM-DD-YYYY	Name of Patentee or Applicant	Pages, Columns, Lines Where Relevant Passages or Relevant Figures Appear
	1	3,972,010	07-27-1976	Dolby	
	2	4,200,889	04-19-1980	Strobele	
	3	4,316,213	02-16-1982	Wharton et al.	
	4	4,450,487	05-22-1984	Koide	
	5	4,561,012	12-24-1985	Acampora	
	6	5,016,107	05-14-1991	Sasson et al.	
	7	5,040,063	08-13-1991	Citta et al.	
	8	5,049,983	09-17-1991	Matsumoto et al.	
	9	5,249,053	09-28-1993	Jain	
	10	5,255,083	10-19-1993	Capitant et al.	
	11	5,303,062	04-12-1994	Kawarai	
	12	5,343,243	08-30-1994	Maeda	
	13	5,442,718	08-15-1995	Kobayashi et al.	
	14	5,526,047	06-11-1996	Sawanobori	
	15	5,535,246	07-09-1996	Beech	
	16	5,537,157	07-16-1996	Washino et al.	
	17	5,563,655	10-08-1996	Lathrop	
	18	5,592,224	01-07-1997	Shim	
	19	5,592,237	01-07-1997	Greenway	
	20	5,818,524	10-06-1998	Juen	
	21	5,875,122	02-23-1999	Acharya	
	22	5,949,468	09-07-1999	Asahina et al.	
	23	5,991,515	11-23-1999	Fall et al.	
	24	5,999,220	12-07-1999	Washino	
	25	6,009,201	12-28-1999	Acharya	
	26	6,124,811	09-26-2000	Acharya et al.	
	27	6,154,493	11-28-2000	Acharya et al.	
	28	6,192,086	02-20-2001	Darr	
	29	6,198,505	03-06-2001	Turner et al.	

Examiner Signature	/Trung Diep/	Date Considered	11/10/2014
--------------------	--------------	-----------------	------------

***Examiner:** Initial if reference considered, whether or not citation is in conformance with MPEP 609. Draw line through citation if not in conformance and not considered. Include copy of this form with next communication to applicant.

T¹ - Place a check mark in this area when an English language translation is attached. **ALL REFERENCES CONSIDERED EXCEPT WHERE LINED THROUGH. /T.D./**

INFORMATION DISCLOSURE STATEMENT BY APPLICANT	Application No.	14/485612
	Filing Date	September 12, 2014
	First Named Inventor	James H. Jannard
	Art Unit	2661
<i>(Multiple sheets used when necessary)</i>	Examiner	Unknown
SHEET 2 OF 14	Attorney Docket No.	REDCOM.007C4

U.S. PATENT DOCUMENTS					
Examiner Initials	Cite No.	Document Number <i>Number - Kind Code (if known)</i> Example: 1,234,567 B1	Publication Date MM-DD-YYYY	Name of Patentee or Applicant	Pages, Columns, Lines Where Relevant Passages or Relevant Figures Appear
	30	6,262,763	07-17-2001	Totsuka	
	31	6,269,217	07-31-2001	Rodriguez	
	32	6,275,263	08-14-2001	Hu	
	33	6,285,794	09-04-2001	Georgiev et al.	
	34	6,314,206	11-06-2001	Sato	
	35	6,466,699	10-15-2002	Schwartz et al.	
	36	6,567,988	05-20-2003	Okawa	
	37	6,597,860	07-22-2003	Song et al.	
	38	6,697,106	02-24-2004	Saito	
	39	6,778,709	08-17-2004	Taubman	
	40	6,798,901	09-28-2004	Acharya et al.	
	41	6,825,876	11-30-2004	Easwar et al.	
	42	6,859,226	02-22-2005	Kawamura et al.	
	43	6,867,717	03-15-2005	Ion	
	44	6,937,276	08-30-2005	Chung	
	45	6,944,349	09-13-2005	Onno et al.	
	46	6,958,774	10-25-2005	Kuroiwa	
	47	6,983,074	01-03-2006	Clauson et al.	
	48	6,989,773	01-24-2006	Wee et al.	
	49	6,990,240	01-24-2006	Hagiwara	
	50	6,995,793	02-07-2006	Albadawi et al.	
	51	6,995,794	02-07-2006	Hsu et al.	
	52	7,038,719	05-02-2006	Hirai	
	53	7,050,642	05-23-2006	Graffagnino	
	54	7,092,016	08-15-2006	Morton et al.	
	55	7,095,899	08-22-2006	Malvar	
	56	7,110,605	09-19-2006	Marcellin et al.	
	57	7,113,645	09-26-2006	Sano et al.	
	58	7,126,634	10-24-2006	Kato	

Examiner Signature	/Trung Diep/	Date Considered	11/10/2014
--------------------	--------------	-----------------	------------

***Examiner:** Initial if reference considered, whether or not citation is in conformance with MPEP 609. Draw line through citation if not in conformance and not considered. Include copy of this form with next communication to applicant.

T¹ - Place a check mark in this area when an English language translation is attached. ALL REFERENCES CONSIDERED EXCEPT WHERE LINED THROUGH. /T.D./

INFORMATION DISCLOSURE STATEMENT BY APPLICANT	Application No.	14/485612
	Filing Date	September 12, 2014
	First Named Inventor	James H. Jannard
	Art Unit	2661
<i>(Multiple sheets used when necessary)</i>	Examiner	Unknown
SHEET 3 OF 14	Attorney Docket No.	REDCOM.007C4

U.S. PATENT DOCUMENTS					
Examiner Initials	Cite No.	Document Number <i>Number - Kind Code (if known)</i> Example: 1,234,567 B1	Publication Date MM-DD-YYYY	Name of Patentee or Applicant	Pages, Columns, Lines Where Relevant Passages or Relevant Figures Appear
	59	7,127,116	10-24-2006	Goldstein et al.	
	60	7,155,066	12-26-2006	Baharav	
	61	7,174,045	02-06-2007	Yokonuma	
	62	7,212,313	05-01-2007	Hoel	
	63	7,253,836	08-07-2007	Suzuki et al.	
	64	7,312,821	12-25-2007	Voss	
	65	7,313,286	12-25-2007	Schwartz et al.	
	66	7,324,141	01-29-2008	Kubo et al.	
	67	7,343,043	03-11-2008	Yokonuma	
	68	7,349,579	03-25-2008	Kadowaki et al.	
	69	7,365,658	04-29-2008	Todorov et al.	
	70	7,369,161	05-06-2008	Easwar et al.	
	71	7,376,183	05-20-2008	Weigand et al.	
	72	7,385,647	06-10-2008	Park	
	73	7,388,992	06-17-2008	Atsumi et al.	
	74	7,394,485	07-01-2008	Kim	
	75	7,477,781	01-13-2009	Tanbakuchi	
	76	7,483,909	01-27-2009	Sena et al.	
	77	7,512,283	03-31-2009	Brower	
	78	7,526,134	04-28-2009	Matsubara	
	79	7,577,689	08-18-2009	Masinter et al.	
	80	7,590,301	09-15-2009	Wu	
	81	7,609,300	10-27-2009	Wu	
	82	7,778,473	08-17-2010	Kodama	
	83	7,796,186	09-14-2010	Oshima	
	84	7,830,967 (and entire prosecution history) (REDCOM.007CP1C1)	11-09-2010	Jannard et al.	
	85	7,868,879	01-11-2011	Rizko	
	86	7,898,575	03-01-2011	Ishii	

Examiner Signature	/Trung Diep/	Date Considered	11/10/2014
--------------------	--------------	-----------------	------------

***Examiner:** Initial if reference considered, whether or not citation is in conformance with MPEP 609. Draw line through citation if not in conformance and not considered. Include copy of this form with next communication to applicant.

T¹ - Place a check mark in this area when an English language translation is attached. **ALL REFERENCES CONSIDERED EXCEPT WHERE LINED THROUGH. /T.D./**

INFORMATION DISCLOSURE STATEMENT BY APPLICANT	Application No.	14/485612
	Filing Date	September 12, 2014
	First Named Inventor	James H. Jannard
	Art Unit	2661
<i>(Multiple sheets used when necessary)</i>	Examiner	Unknown
SHEET 4 OF 14	Attorney Docket No.	REDCOM.007C4

U.S. PATENT DOCUMENTS					
Examiner Initials	Cite No.	Document Number <i>Number - Kind Code (if known)</i> Example: 1,234,567 B1	Publication Date MM-DD-YYYY	Name of Patentee or Applicant	Pages, Columns, Lines Where Relevant Passages or Relevant Figures Appear
	87	7,907,791	03-15-2011	Kinrot	
	88	7,936,919	05-03-2011	Kameyama	
	89	8,014,597	09-06-2011	Newman	
	90	8,174,560 C1 (and entire prosecution history) (REDCOM.007A)	05-16-2014	Jannard et al.	
	91	8,237,830 (and entire prosecution history) (REDCOM.007CP1)	08-07-2012	Jannard et al.	
	92	8,358,357 (and entire prosecution history) (REDCOM.007C2)	01-22-2013	Jannard et al.	
	93	RE 37,342	08-02-2001	Washino et al.	
	94	RE 38,079	04-15-2003	Washino et al.	
	95	2002/0041707	04-11-2002	Newman	
	96	2002/0063787	05-30-2002	Watanabe	
	97	2002/0196354	12-26-2002	Chang et al.	
	98	2003/0007567	01-09-2003	Newman et al.	
	99	2003/0011747	01-16-2003	Lenz	
	100	2003/0018750	01-23-2003	Onno et al.	
	101	2003/0038885	02-27-2003	Rodriguez	
	102	2003/0122037	07-03-2003	Hyde et al.	
	103	2003/0122937	07-03-2003	Guarnera et al.	
	104	2003/0156188	08-21-2003	Abrams Jr.	
	105	2003/0185302	10-02-2003	Abrams Jr.	
	106	2003/0202106	10-30-2003	Kanleinsberger et al.	
	107	2004/0051793	03-18-2004	Tecu	
	108	2004/0095477	05-20-2004	Maki et al.	
	109	2004/0131274	07-08-2004	Perlmutter et al.	
	110	2004/0165080	08-26-2004	Burks et al.	
	111	2004/0169746	09-02-2004	Chen et al.	
	112	2004/0169751	09-02-2004	Takemura et al.	
	113	2004/0196389	10-07-2004	Honda	

Examiner Signature	/Trung Diep/	Date Considered	11/10/2014
--------------------	--------------	-----------------	------------

***Examiner:** Initial if reference considered, whether or not citation is in conformance with MPEP 609. Draw line through citation if not in conformance and not considered. Include copy of this form with next communication to applicant.

T¹ - Place a check mark in this area when an English language translation is attached. **ALL REFERENCES CONSIDERED EXCEPT WHERE LINED THROUGH. /T.D./**

INFORMATION DISCLOSURE STATEMENT BY APPLICANT	Application No.	14/485612
	Filing Date	September 12, 2014
	First Named Inventor	James H. Jannard
	Art Unit	2661
<i>(Multiple sheets used when necessary)</i>	Examiner	Unknown
SHEET 5 OF 14	Attorney Docket No.	REDCOM.007C4

U.S. PATENT DOCUMENTS					
Examiner Initials	Cite No.	Document Number <i>Number - Kind Code (if known)</i> Example: 1,234,567 B1	Publication Date MM-DD-YYYY	Name of Patentee or Applicant	Pages, Columns, Lines Where Relevant Passages or Relevant Figures Appear
	114	2004/0201701	10-14-2004	Takagi	
	115	2004/0213472	10-28-2004	Kodama et al.	
	116	2004/0218812	11-04-2004	Douglass	
	117	2004/0246346	12-09-2004	Kim et al.	
	118	2005/0182972	08-18-2005	Apostolopoulos et al.	
	119	2005/0183118	08-18-2005	Wee et al.	
	120	2005/0276496	12-15-2005	Molgaard et al.	
	121	2005/0286797	12-29-2005	Hayaishi	
	122	2006/0007324	01-12-2006	Takei	
	123	2006/0012694	01-19-2006	Yoneda et al.	
	124	2006/0061659	03-23-2006	Niwa	
	125	2006/0061822	03-23-2006	Sung et al.	
	126	2006/0114987	06-01-2006	Roman	
	127	2006/0165178	07-26-2006	Ma et al.	
	128	2006/0165179	07-26-2006	Feuer et al.	
	129	2006/0170786	08-03-2006	Won	
	130	2006/0221199	10-05-2006	Nakajima	
	131	2006/0221203	10-05-2006	Abe et al.	
	132	2006/0221230	10-05-2006	Dutt et al.	
	133	2006/0244842	11-02-2006	Hatano	
	134	2007/0035636	02-15-2007	Wu	
	135	2007/0041634	02-22-2007	Sugimori	
	136	2007/0051817	03-08-2007	Yano	
	137	2007/0091187	04-26-2007	Lin	
	138	2007/0092149	04-26-2007	Sung	
	139	2007/0109316	05-17-2007	Fainstain	
	140	2007/0127095	06-07-2007	Sugimori	
	141	2007/0153093	07-05-2007	Lin et al.	
	142	2007/0160142	07-12-2007	Abrams Jr.	

Examiner Signature	/Trung Diep/	Date Considered	11/10/2014
--------------------	--------------	-----------------	------------

***Examiner:** Initial if reference considered, whether or not citation is in conformance with MPEP 609. Draw line through citation if not in conformance and not considered. Include copy of this form with next communication to applicant.

T¹ - Place a check mark in this area when an English language translation is attached. ALL REFERENCES CONSIDERED EXCEPT WHERE LINED THROUGH. /T.D./

INFORMATION DISCLOSURE STATEMENT BY APPLICANT	Application No.	14/485612
	Filing Date	September 12, 2014
	First Named Inventor	James H. Jannard
	Art Unit	2661
<i>(Multiple sheets used when necessary)</i>	Examiner	Unknown
SHEET 6 OF 14	Attorney Docket No.	REDCOM.007C4

U.S. PATENT DOCUMENTS					
Examiner Initials	Cite No.	Document Number <i>Number - Kind Code (if known)</i> Example: 1,234,567 B1	Publication Date MM-DD-YYYY	Name of Patentee or Applicant	Pages, Columns, Lines Where Relevant Passages or Relevant Figures Appear
	143	2007/0165116	07-19-2007	Hung et al.	
	144	2007/0206852	09-06-2007	McGee	
	145	2007/0216782	09-20-2007	Chernoff	
	146	2007/0285517	12-13-2007	Ishikuro	
	147	2008/0002035	01-03-2008	Yoshida	
	148	2008/0012953	01-17-2008	Yang et al.	
	149	2008/0018746	01-24-2008	Kawanami	
	150	2008/0055426	03-06-2008	Pertsel et al.	
	151	2008/0062272	03-13-2008	Kuroiwa	
	152	2008/0063070	03-13-2008	Schwartz et al.	
	153	2008/0079818	04-03-2008	Takahashi	
	154	2008/0084581	04-10-2008	Kobayashi et al.	
	155	2008/0131013	06-05-2008	Suino et al.	
	156	2008/0259180	10-23-2008	Ovsiannikov	
	157	2008/0273809	11-06-2008	Demos	
	158	2008/0284485	11-20-2008	Schilling	
	159	2008/0301315	12-04-2008	Cheng et al.	
	160	2009/0052797	02-26-2009	Matsushita	
	161	2009/0052861	02-26-2009	Goldman	
	162	2009/0080784	03-26-2009	Luh et al.	
	163	2009/0141140	06-04-2009	Robinson	
	164	2010/0014590	01-21-2010	Smith	
	165	2010/0111489	05-06-2010	Presler	
	166	2012/0294582 (and entire prosecution history) (REDCOM.007C1)	11-22-2012	Jannard et al.	
	167	2013/0113951 (and entire prosecution history) (REDCOM.007CP1C2)	05-09-2013	Jannard et al.	
	168	2014/0226036	08-14-2014	Jannard et al.	

FOREIGN PATENT DOCUMENTS

Examiner Signature	/Trung Diep/	Date Considered	11/10/2014
--------------------	--------------	-----------------	------------

***Examiner:** Initial if reference considered, whether or not citation is in conformance with MPEP 609. Draw line through citation if not in conformance and not considered. Include copy of this form with next communication to applicant.

T¹ - Place a check mark in this area when an English language translation is attached. **ALL REFERENCES CONSIDERED EXCEPT WHERE LINED THROUGH. /T.D./**

INFORMATION DISCLOSURE STATEMENT BY APPLICANT	Application No.	14/485612
	Filing Date	September 12, 2014
	First Named Inventor	James H. Jannard
	Art Unit	2661
<i>(Multiple sheets used when necessary)</i>	Examiner	Unknown
SHEET 7 OF 14	Attorney Docket No.	REDCOM.007C4

Examiner Initials	Cite No.	Foreign Patent Document Country Code-Number-Kind Code Example: JP 1234567 A1	Publication Date MM-DD-YYYY	Name of Patentee or Applicant	Pages, Columns, Lines Where Relevant Passages or Relevant Figures Appear	T ¹
	169	CA 2,683,636	01-28-2014	Red.com, Inc.		
	170	EP 1 605 403	12-14-2005	ST Microelectronics		
	171	EP 2 145 330	01-20-2010	Red.com, Inc.		
	172	JP 06-054239	02-25-1994	Canon Inc.		X-Abs
	173	JP 2000-069488	03-03-2000	Nikon Corp.		X
	174	JP 2001-515318	09-18-2001	Intel Corporation		X
	175	JP 2002-051266	02-15-2002	Sony Corp.		X
	176	JP 2004-038693	02-05-2004	Canon Inc.		X
	177	JP 2004-248061	09-02-2004	Fuji Photo Film Co., Ltd.		X
	178	JP 2004-260821	09-16-2004	Hewlett-Packard Development Co. LP		X
	179	JP 2004-282780	10-07-2004	Canon Inc.		X
	180	JP 2004-349842	12-09-2004	Fuji Photo Film Co., Ltd.		X
	181	JP 2005-210216	08-04-2005	Konica Minolta Photo Imaging Inc.		X
	182	JP 2006-171524	06-29-2006	Sanyo Electric Co., Ltd.		X
	183	JP 2006-311314	11-09-2006	Matsushita Electric Ind. Co., Ltd.		X
	184	JP 2007-267072	10-11-2007	Sanyo Electric Co., Ltd.		X
	185	JP 2012-523790 (REDCOM.007QPC)	10-04-2012	Red.com, Inc.		X
	186	KR 10-2002-0041778	06-03-2002	Sharp Corporation		X-Abs
	187	WO 91/001613	02-07-1991	Eastman Kodak Co.		
	188	WO 97/009818	03-13-1997	Starcam Systems Inc.		
	189	WO 2008/128112 (REDCOM.007VPC)	10-23-2008	Red.com, Inc.		
	190	WO 92/010911	06-25-1992	Eastman Kodak Co.		
	191	KR 10-2009-0035204	04-09-2009	Samsung Electronics Co., Ltd.		X-Abs

NON PATENT LITERATURE DOCUMENTS

Examiner Initials	Cite No.	Include name of the author (in CAPITAL LETTERS), title of the article (when appropriate), title of the item (book, magazine, journal, serial, symposium, catalog, etc.), date, page(s), volume-issue number(s), publisher, city and/or country where published.	T ¹

Examiner Signature	/Trung Diep/	Date Considered	11/10/2014
--------------------	--------------	-----------------	------------

***Examiner:** Initial if reference considered, whether or not citation is in conformance with MPEP 609. Draw line through citation if not in conformance and not considered. Include copy of this form with next communication to applicant.

T¹ - Place a check mark in this area when an English language translation is attached. **ALL REFERENCES CONSIDERED EXCEPT WHERE LINED THROUGH. /T.D./**

INFORMATION DISCLOSURE STATEMENT BY APPLICANT	Application No.	14/485612
	Filing Date	September 12, 2014
	First Named Inventor	James H. Jannard
	Art Unit	2661
<i>(Multiple sheets used when necessary)</i>	Examiner	Unknown
SHEET 8 OF 14	Attorney Docket No.	REDCOM.007C4

NON PATENT LITERATURE DOCUMENTS

Examiner Initials	Cite No.	Include name of the author (in CAPITAL LETTERS), title of the article (when appropriate), title of the item (book, magazine, journal, serial, symposium, catalog, etc.), date, page(s), volume-issue number(s), publisher, city and/or country where published.	T ¹
	192	2K Digital Cinema Camera Streamlines Movie and HD Production, Silicon Imaging Digital Cinema, Press News Releases, Hollywood, California, date listed November 1, 2006, in 2 pages. (www.siliconimaging.com_DigitalCinema_News_PR_11_01_06_1)	
	193	4:4:4 12-bit Uncompressed DVX100, date listed May 11 - 16, 2004, in 9 pages. (http://www.dvinfo.net/forum/archive/index.php/t-20332-p-13.html)	
	194	Abel Cine, "Abel North American Agent for Phantom Cameras," February 7, 2007, http://web.archive.org/web/20120523003248/http://about.abelcine.com/2007/02/07/abel-north-american-agent-for-phantom-cameras/ in 2 pages.	
	195	ARRIFLEX D-20 Preliminary Specifications, archive.org indicates available on-line on May 31, 2005, www.arri.com , [online], http://web.archive.org/web/20050531010626/www.arri.com/entry/products.htm , pp. 1-2	
	196	ARRIFLEX D-21: The Film Style Digital Camera, date listed January 4, 2008, www.arri.de , [online] http://www.arri.de/press/press/press_release.html?tx_ttnews[tt_news]=32&tx_ttnews[backPid]=1781&cHash=e89c9b0855e89c9b0855	
	197	BRUNER, Guy, Silicon Imaging Shows 1920x1080P Camera System, Camcorder News, Las Vegas, NAB, date listed April 25, 2006, in 8 pages. (http://www.camcorderinfo.com/content/Silicon-Imaging-Shows-1920x1080P-Camera-System.htm)	
	198	CineForm Insider, blog post dated November 13, 2007; http://cineform.blogspot.com/2007/11/cineform-on-chip.html , in 3 pages	
	199	CineForm Insider, date listed as January through December, 2006, in 17 pages. (http://cineform.blogspot.com/search?updated-min=2006-01-01T00:00:00-08:00&updated-max=2007-01-01T00:00:00-08:00&max-results=22)	
	200	CineForm Online Workflow Solutions for Film and Video - November 1, 2006	
	201	CineForm Raw - Dalsa and Vision Research Raw File Converters, printed August 16, 2010, www.cineform.com , [online].	
	202	CineForm RAW - Technology Overview and Workflow, date listed April 13, 2006, in 3 pages.	
	203	CinemaTechnic Camera Profiles ARRI 16SR, date listed 2001	
	204	Dalsa Origin Brochure, document indicates that it was printed April 2004, in 2 pages.	
	205	"Dalsa Technology with Vision," Presentation, March 2003, pp. 35.	
	206	Defendant's Answer, Affirmative Defenses and Counterclaims; Demand for Jury Trial; RED.COM, Inc. v. Sony Corporation of America and Sony Electronics Inc., Case No. 13CV0334-DMS-BGS, dated June 20, 2013.	
	207	Digital Negative (DNG) Specification, date listed April 2008	

Examiner Signature	/Trung Diep/	Date Considered	11/10/2014
--------------------	--------------	-----------------	------------

***Examiner:** Initial if reference considered, whether or not citation is in conformance with MPEP 609. Draw line through citation if not in conformance and not considered. Include copy of this form with next communication to applicant.

T¹ - Place a check mark in this area when an English language translation is attached. **ALL REFERENCES CONSIDERED EXCEPT WHERE LINED THROUGH. /T.D./**

INFORMATION DISCLOSURE STATEMENT BY APPLICANT	Application No.	14/485612
	Filing Date	September 12, 2014
	First Named Inventor	James H. Jannard
	Art Unit	2661
<i>(Multiple sheets used when necessary)</i>	Examiner	Unknown
SHEET 9 OF 14	Attorney Docket No.	REDCOM.007C4

NON PATENT LITERATURE DOCUMENTS

Examiner Initials	Cite No.	Include name of the author (in CAPITAL LETTERS), title of the article (when appropriate), title of the item (book, magazine, journal, serial, symposium, catalog, etc.), date, page(s), volume-issue number(s), publisher, city and/or country where published.	T ¹
	208	DOUTRE et al., "An Efficient Compression Scheme for Colour Filter Array Images Using Estimated Colour Difference", IEEE Canadian conference on Electrical and Computer Engineering, date listed 2007, pp.24-27	
	209	ION, Lucian, et al., High Dynamic Range Data Centric Workflow System, DALSA Digital Cinema, this paper reported to be originally presented at SMPTE Technical Conference and Exhibit, New York, date listed November 2005, in 14 pages.	
	210	ION, Lucian, et al., White Paper: 4K Digital Capture and Postproduction Workflow, DALSA Digital Cinema, in 5 pages.	
	211	ISO Standard 15444 (part 1): Information technology - JPEG 2000 image coding system: Core coding system, pages i-v, xiv, 1-11,120-122, copyright date listed is 2004.	
	212	JPEG 2000 still image coding versus other standards, date listed July 2000	
	213	LUKAC et al.: Single-sensor camera image compression, date listed May 2006, pages 299-307.	
	214	MENON et al., "On The Dependency Between Compression and Demosaicing In Digital Cinema", Visual Media Production, The 2nd IEEE European Conference, Nov. 30 - Dec. 1, 2005, pp. 104 - 111.	
	215	MITANI, et al.; A 4 K x 2 K-pixel color image pickup system; IEICE Transactions on Information and Systems; E82D (8): 1219-1227; August -1999	
	216	MITANI, et al.; Ultrahigh-definition color video camera system with 4K-scanning lines; Sensors and Camera Systems for Scientific, Industrial, and Digital Photography Applications IV, 5017: 159-166, 2003	
	217	New Camcorder from Silicon Imaging, © 2006-2008 Digital Camcorder News, date listed April 19, 2006, in 2 pages. http://www.digitalcamcordernews.com/2006/04/new-camcorder-from-silicon-imaging)	
	218	NORDHAUSER, Steve, Silicon Imaging Announces World's First Digital Cinema Camera with Direct-to-Disk 10-bit CineForm RAW™ Recording and Adobe® Production Studio Integration, Silicon Imaging, Inc., Albany, New York, date listed June 26, 2006, in 3 pages. (http://www.filmmakers.com/news/digital/article_713.shtml)	
	219	Notes from the field: Silicon Imaging SI-1920HDVR camera in actual use, FRESHDV, date listed May 18, 2006, in 2 pages. (http://www.freshdv.com/2006/05/notes-from-field-silicon-imaging-si.html)	
	220	PHANTOM 65 the world's first 65mm digital cinema, date listed Nov 22, 2006	
	221	PHANTOM 65, archive.org indicates available on-line February 4, 2007, www.visionresearch.com , [online], http://web.archive.org/web/20070204110551/www.visionresearch.com/index.cfm?sector=htm/files&page=camera_65_new , pp. 1-2	
	222	"Phantom HD", http://www.alfavisionsrl.com.ar/espanol/alquiler/camera/info/manuals/DS_phantomHD.pdf , dated March 30, 2007, pp. 2.	
	223	Compiled by PUHOVSKI, NENAD, High Definition Report from Cilect Standing Committee for New Technologies, Madrid, date listed 2006, in 146 pages.	

Examiner Signature	/Trung Diep/	Date Considered	11/10/2014
--------------------	--------------	-----------------	------------

***Examiner:** Initial if reference considered, whether or not citation is in conformance with MPEP 609. Draw line through citation if not in conformance and not considered. Include copy of this form with next communication to applicant.

T¹ - Place a check mark in this area when an English language translation is attached. ~~ALL REFERENCES CONSIDERED EXCEPT WHERE LINED THROUGH. /T.D./~~

INFORMATION DISCLOSURE STATEMENT BY APPLICANT	Application No.	14/485612
	Filing Date	September 12, 2014
	First Named Inventor	James H. Jannard
	Art Unit	2661
<i>(Multiple sheets used when necessary)</i>	Examiner	Unknown
SHEET 10 OF 14	Attorney Docket No.	REDCOM.007C4

NON PATENT LITERATURE DOCUMENTS

Examiner Initials	Cite No.	Include name of the author (in CAPITAL LETTERS), title of the article (when appropriate), title of the item (book, magazine, journal, serial, symposium, catalog, etc.), date, page(s), volume-issue number(s), publisher, city and/or country where published.	T ¹
	224	"RED Digital Cinema", < http://www.dvxuser.com/articles/redteam/RED-DVXUSER.pdf >, December 31, 2006, pp. 2.	
	225	"Red Exclusive Brochure", www.dvxuser.com, retrieved on February 5, 2013, in 1 page http://www.dvxuser.com/V6/archive/index.php/t-54786.html	
	226	RED vs DALSA ORIGIN, REDUSER.net, The DSMC System, Red One, date listed October 26, 2007, in 5 pages. (http://www.reduser.net/forum/archive/index.php/t-5344.html)	
	227	ROBIN, Gamma Correction, www.broadcastengineering.com [online], date listed January 1, 2005 in 5 pages.	
	228	NAB2006DayThree, archive.org indicates available on-line March 2, 2007, [on-line] http://web.archive.org/web/20070302002153/http://web.mac.com/mikedcurtis/iWeb/HD4NDs_Image_Galleries/NAB2006DayThreePt1.html , in 5 pages.	
	229	SI-2K Digital Cinema Camera, Silicon Imaging, copyright date listed is 2007, in 14 pages.	
	230	Silicon Imaging SI-2K MINI Full Specifications, archive.org indicates available on-line May 23, 2007, www.siliconimaging.com, [online], http://web.archive.org/web/20070523223217/www.siliconimaging.com/DigitalCinema/SI_2K_full_specifications.html , pp. 1-2	
	231	Silicon Imaging, PRESS News Releases, www.siliconimaging.com/DigitalCinema/SI_Press.html, printed November 5, 2012.	
	232	Silicon Imaging Support: Frequently-Asked-Questions, archive.org indicates available on-line December 12, 2007, www.siliconimaging.com, [online], http://web.archive.org/web/20071212165310/www.siliconimaging.com/DigitalCinema/SiliconImaging_faq.html , in 12 pages.	
	233	SI-1920HDVR Key Features, Silicon Imaging Digital Cinema, in 2 pages. (http://www.siliconimaging.com/DigitalCinema/key_features.html)	
	234	SMITH, et al.; Constant quality JPEG2000 rate control for digital cinema; Source: Proceedings of SPIE - The International Society for Optical Engineering, v 6508, n PART 1, 2007, Conference: Visual Communications and Image Processing 2007, January 30, 2007 - February 1, 2007	
	235	SMITH, et al., Image Resolution of the One-CCD Palomar Motion Picture Camera, 37th Advance Motion Imaging Conference, Seattle, Washington, date listed February 27-March 1, 2003, in 8 pages.	
	236	Some Like It Raw, Silicon Imaging D-Cinema Camera with Cineform RAW Codec, Studio Daily, date listed May 8, 2006, [on-line] http://www.studiodaily.com/2006/05/some-like-it-raw/	
	237	THE RED ONE CAMERA 4K Resolution, various dates listed, starting from February 7th, 2007, URL: http://www.vnnforum.com/showthread.php?t=44489 [retrieved on 2012-08-03]	
	238	WILT, Adam, Camera Log, NAB 2009 - SI-2K, date listed April 19, 2009, in 5 pages. (http://provideocoalition.com/index.php/awilt/story/nab_2009_si_2k/)	
	239	ZENG, Jianfen, et al., Video Coding Techniques for Digital Cinema, ©2004 IEEE International Conference on Multimedia and Expo (ICME), pages 415-418, Vol. 1.	

Examiner Signature	/Trung Diep/	Date Considered	11/10/2014
--------------------	--------------	-----------------	------------

***Examiner:** Initial if reference considered, whether or not citation is in conformance with MPEP 609. Draw line through citation if not in conformance and not considered. Include copy of this form with next communication to applicant.

T¹ - Place a check mark in this area when an English language translation is attached. ~~ALL REFERENCES CONSIDERED EXCEPT WHERE LINED THROUGH. /T.D./~~

INFORMATION DISCLOSURE STATEMENT BY APPLICANT	Application No.	14/485612
	Filing Date	September 12, 2014
	First Named Inventor	James H. Jannard
	Art Unit	2661
<i>(Multiple sheets used when necessary)</i>	Examiner	Unknown
SHEET 11 OF 14	Attorney Docket No.	REDCOM.007C4

NON PATENT LITERATURE DOCUMENTS

Examiner Initials	Cite No.	Include name of the author (in CAPITAL LETTERS), title of the article (when appropriate), title of the item (book, magazine, journal, serial, symposium, catalog, etc.), date, page(s), volume-issue number(s), publisher, city and/or country where published.	T ¹
	240	ZHANG et al. Real-time lossless compression of mosaic video sequences, Zhang, L; Wu, X; Bao, P, date listed 10 August 2005, in 8 pages	
	241	Complaint for Patent Infringement; <i>RED.COM, INC., Inc. v. Sony Corporation of America and Sony Electronics, Inc.</i> , U.S. District Court for the Southern District of California, Case No.: 3:13-cv-00334-DMS-BGS, dated February 12, 2013.	
	242	Joint Motion for Dismissal Without Prejudice; <i>RED.COM, Inc. v. Sony Corporation of America and Sony Electronics Inc.</i> , Case No. 13CV0334-DMS-BGS, dated July 19, 2013.	
	243	On-line discussion thread from www.dvxuser.com, first post in thread dated May 1, 2006, retrieved from http://www.dvxuser.com/V6/showthread.php?55590-Worried-about-depending-on-RED-codec	
	244	On-line discussion thread from www.dvxuser.com, first post in thread dated September 8, 2006, retrieved from http://www.dvxuser.com/V6/showthread.php?70333-Workflow-(good)-News	
	245	On-line discussion thread from www.dvxuser.com, first post in thread dated September 8, 2006, retrieved from http://www.dvxuser.com/V6/showthread.php?70412-First-video-from-the-RED-4K-demo!	
	246	On-line discussion thread from www.dvxuser.com, first post in thread dated September 8, 2006, retrieved from http://www.dvxuser.com/V6/showthread.php?70417-RED-workflow-(how-we-prepared-the-Red-Footage-for-IBC)	
	247	On-line discussion thread from www.dvxuser.com, first post in thread dated September 10, 2006, retrieved from http://www.dvxuser.com/V6/showthread.php?70671-4K-RAW-data-rates	
	248	On-line discussion thread from www.dvxuser.com, first post in thread dated September 18, 2006, retrieved from http://www.dvxuser.com/V6/showthread.php?71703-Dynamic-Range	
	249	On-line discussion thread from www.dvxuser.com, first post in thread dated September 19, 2006, retrieved from http://www.dvxuser.com/V6/showthread.php?71756-RED-code-RAW-lossless-lossy	
	250	On-line discussion thread from www.dvxuser.com, first post in thread dated September 24, 2006, retrieved from http://www.dvxuser.com/V6/showthread.php?72306-4k-live-(-4k-Still-from-Red-One-is-up-)	
	251	On-line discussion thread from www.dvxuser.com, first post in thread dated October 2, 2006, retrieved from http://www.dvxuser.com/V6/showthread.php?73415-1st-video-posted	
	252	On-line discussion thread from www.dvxuser.com, first post in thread dated October 3, 2006, retrieved from http://www.dvxuser.com/V6/showthread.php?73448-editing-4K-at-home	
	253	On-line discussion thread from www.dvxuser.com, first post in thread dated October 9, 2006, retrieved from http://www.dvxuser.com/V6/showthread.php?74232-1k-Bubble-Girl-video-up	
	254	On-line discussion thread from www.dvxuser.com, first post in thread dated October 31, 2006, retrieved from http://www.dvxuser.com/V6/showthread.php?76711-First-REDCODE-image!	

Examiner Signature	/Trung Diep/	Date Considered	11/10/2014
--------------------	--------------	-----------------	------------

***Examiner:** Initial if reference considered, whether or not citation is in conformance with MPEP 609. Draw line through citation if not in conformance and not considered. Include copy of this form with next communication to applicant.

T¹ - Place a check mark in this area when an English language translation is attached.

INFORMATION DISCLOSURE STATEMENT BY APPLICANT	Application No.	14/485612
	Filing Date	September 12, 2014
	First Named Inventor	James H. Jannard
	Art Unit	2661
<i>(Multiple sheets used when necessary)</i>	Examiner	Unknown
SHEET 12 OF 14	Attorney Docket No.	REDCOM.007C4

NON PATENT LITERATURE DOCUMENTS

Examiner Initials	Cite No.	Include name of the author (in CAPITAL LETTERS), title of the article (when appropriate), title of the item (book, magazine, journal, serial, symposium, catalog, etc.), date, page(s), volume-issue number(s), publisher, city and/or country where published.	T ¹
	255	On-line discussion thread from www.dvxuser.com, first post in thread dated November 3, 2006, retrieved from http://www.dvxuser.com/V6/showthread.php?76954-Red-still-gallery-updated-with-new-4k-still!	
	256	On-line discussion thread from www.dvxuser.com, first post in thread dated November 4, 2006, retrieved from http://www.dvxuser.com/V6/showthread.php?77032-RAW-vs-REDCODE-RAW	
	257	On-line discussion thread from www.dvxuser.com, first post in thread dated November 5, 2006, retrieved from http://www.dvxuser.com/V6/showthread.php?77117-Slo-Mo-and-REDCODE-RAW-questions	
	258	On-line discussion thread from www.dvxuser.com, first post in thread dated November 6, 2006, retrieved from http://www.dvxuser.com/V6/showthread.php?77216-120fps-at-4K	
	259	On-line discussion thread from www.dvxuser.com, first post in thread dated November 13, 2006, retrieved from http://www.dvxuser.com/V6/showthread.php?78010-David-Stump-on-Red	
	260	On-line discussion thread from www.dvxuser.com, first post in thread dated November 14, 2006, retrieved from http://www.dvxuser.com/V6/showthread.php?78150-RED-L-A-photos-what-have-you-s	
	261	On-line discussion thread from www.dvxuser.com, first post in thread dated November 15, 2006, retrieved from http://www.dvxuser.com/V6/showthread.php?78290-Red-Camera-first-test-with-Still-Lens-(-Nikon-)	
	262	On-line discussion thread from www.dvxuser.com, first post in thread dated November 19, 2006, retrieved from http://www.dvxuser.com/V6/showthread.php?78623-Red-compression-and-matrix-tests	
	263	On-line discussion thread from www.dvxuser.com, first post in thread dated November 20, 2006, retrieved from http://www.dvxuser.com/V6/showthread.php?78823-Image-links-fixed	
	264	On-line discussion thread from www.dvxuser.com, first post in thread dated November 21, 2006, retrieved from http://www.dvxuser.com/V6/showthread.php?78934-redcode-amazingly-good-!	
	265	On-line discussion thread from www.dvxuser.com, first post in thread dated November 24, 2006, retrieved from http://www.dvxuser.com/V6/showthread.php?79130-More-footage	
	266	On-line discussion thread from www.dvxuser.com, first post in thread dated December 11, 2006, retrieved from http://www.dvxuser.com/V6/showthread.php?80963-NEW-VIDEO!!!-Bus-Video-1080p-clip-online-REDCODE	
	267	On-line discussion thread from www.dvxuser.com, first post in thread dated December 18, 2006, retrieved from http://www.dvxuser.com/V6/showthread.php?81686-Specs-changes	
	268	On-line discussion thread from www.hdforindies.com, first post in thread dated September 8, 2006, retrieved from http://www.hdforindies.com/2006/09/amsterdam-ibc-2006-red-news-redcode-4k.html	
	269	On-line discussion thread from www.hdforindies.com, first post in thread dated December 19, 2006, retrieved from http://www.hdforindies.com/2006/12/mikes-conjecture-on-redcode-data-rates.html	

Examiner Signature	/Trung Diep/	Date Considered	11/10/2014
--------------------	--------------	-----------------	------------

***Examiner:** Initial if reference considered, whether or not citation is in conformance with MPEP 609. Draw line through citation if not in conformance and not considered. Include copy of this form with next communication to applicant.

T¹ - Place a check mark in this area when an English language translation is attached.

INFORMATION DISCLOSURE STATEMENT BY APPLICANT	Application No.	14/485612
	Filing Date	September 12, 2014
	First Named Inventor	James H. Jannard
	Art Unit	2661
<i>(Multiple sheets used when necessary)</i>	Examiner	Unknown
SHEET 13 OF 14	Attorney Docket No.	REDCOM.007C4

NON PATENT LITERATURE DOCUMENTS

Examiner Initials	Cite No.	Include name of the author (in CAPITAL LETTERS), title of the article (when appropriate), title of the item (book, magazine, journal, serial, symposium, catalog, etc.), date, page(s), volume-issue number(s), publisher, city and/or country where published.	T ¹
	270	Order Granting Joint Motion for Dismissal Without Prejudice; RED.COM, Inc. v. Sony Corporation of America and Sony Electronics Inc., Case No. 13CV0334-DMS-BGS, dated July 29, 2013.	
	271	RED DIGITAL CINEMA, "Introducing REDCODE", September 2006, International Broadcasting Convention, Amsterdam, the Netherlands, in 1 page.	
	272	RED DIGITAL CINEMA, "Mysterium Sensor", September 2006, International Broadcasting Convention, Amsterdam, the Netherlands, in 1 page.	
	273	RED DIGITAL CINEMA, "Preliminary Specifications", September 2006, International Broadcasting Convention, Amsterdam, the Netherlands, in 1 page.	
	274	RED DIGITAL CINEMA, "Preliminary Specifications", April 14-19, 2007, Las Vegas, Nevada, in 1 page.	
	275	RED DIGITAL CINEMA, "Simple. 4K to Anything", September 2006, International Broadcasting Convention, Amsterdam, the Netherlands, in 1 page.	
	276	Request for Re-Examination of U.S. Patent No. 8,174,560 (REDCOM.007A), dated September 13, 2012.	
	277	Re-Examination Grant in U.S. Patent No. 8,174,560 (REDCOM.007A), dated December 6, 2012.	
	278	Official Communication in Japanese Application No. 2012-506053 (REDCOM.007QJP), dated October 16, 2013.	
	279	International Search Report and Written Opinion in PCT Application No. PCT/US2010/028808 (REDCOM.007QPC), dated August 3, 2010.	
	280	Examination Report in Australian Application No. 2008240144 (REDCOM.007VAU), dated December 23, 2010.	
	281	Official Communication in Chinese Application No. 200880018570.6 (REDCOM.007VCN), dated March 31, 2014.	
	282	Official Communication in European Application No. 08745686.9 (REDCOM.007VEP), dated March 30, 2010.	
	283	Extended European Search Report in European Application No. 08745686.9 (REDCOM.007VEP), dated August 4, 2011.	
	284	Office Action in European Application No. 08745686.9 (REDCOM.007VEP), dated August 10, 2012.	
	285	Summons to Attend Oral Proceedings in European Application No. 08745686.9 (REDCOM.007VEP), dated October 31, 2013.	
	286	Official Communication in European Application No. 08745686.9 (REDCOM.007VEP), dated February 5, 2014.	
	287	Official Communication in European Application No. 08745686.9 (REDCOM.007VEP), dated March 18, 2014.	
	288	Office Action in Mexican Application No. MX/a/2009/010926 (REDCOM.007VMX), dated May 16, 2012.	

Examiner Signature	/Trung Diep/	Date Considered	11/10/2014
--------------------	--------------	-----------------	------------

***Examiner:** Initial if reference considered, whether or not citation is in conformance with MPEP 609. Draw line through citation if not in conformance and not considered. Include copy of this form with next communication to applicant.

T¹ - Place a check mark in this area when an English language translation is attached. **ALL REFERENCES CONSIDERED EXCEPT WHERE LINED THROUGH. /T.D./**

INFORMATION DISCLOSURE STATEMENT BY APPLICANT	Application No.	14/485612
	Filing Date	September 12, 2014
	First Named Inventor	James H. Jannard
	Art Unit	2661
<i>(Multiple sheets used when necessary)</i>	Examiner	Unknown
SHEET 14 OF 14	Attorney Docket No.	REDCOM.007C4

NON PATENT LITERATURE DOCUMENTS			
Examiner Initials	Cite No.	Include name of the author (in CAPITAL LETTERS), title of the article (when appropriate), title of the item (book, magazine, journal, serial, symposium, catalog, etc.), date, page(s), volume-issue number(s), publisher, city and/or country where published.	T ¹
	289	Office Action in Japanese Application No. 2010-503253 (REDCOM.007VJP), dated June 26, 2012.	
	290	Office Action in Korean Application No. 10-2009-7023045 (REDCOM.007VKR), dated February 6, 2014.	
	291	Examination Report in New Zealand Application No. 580171 (REDCOM.007VNZ), dated February 22, 2011.	
	292	Examination Report in New Zealand Application No. 601474 (REDCOM.007NZD1), dated August 1, 2012.	
	293	Examination Report in New Zealand Application No. 620333 (REDCOM.007NZD2), dated February 14, 2014.	
	294	Written Opinion in PCT Application No. PCT/US2008/060126 (REDCOM.007VPC), dated July 7, 2008.	
	295	International Preliminary Report on Patentability in PCT Application No. PCT/US2008/060126 (REDCOM.007VPC), dated October 13, 2009	
	296	Official Communication in Taiwanese Application No. 097113289 (REDCOM.007VTW), dated August 29, 2013	
	297	Final Office Action in Re-Examination of US Patent No. 8,174,560 (REDCOM.007X1), dated October 31, 2013.	
	298	Notice of Intent to Issue Ex Parte Reexamination Certificate in Re-Examination of US Patent No. 8,174,560 (REDCOM.007X1), dated March 5, 2014.	
	299	International Search Report and Written Opinion in PCT Application No. PCT/US2010/060851 (REDCOM.032WO), dated August 24, 2011.	
	300	International Search Report and Written Opinion in PCT Application No. PCT/US2014/016301 (REDCOM.084WO), dated May 21, 2014.	
	301	Official Communication in Taiwanese Application No. 097113289 (REDCOM.007VTW), dated July 15, 2014	
	302	Official Communication in European Application No. 14177071.9 (REDCOM.007VEPD1), dated August 22, 2014.	
	303	Examination Report in Australian Application No. 2012216606 (REDCOM.007VAUD1), dated July 31, 2014.	
	304	Official Communication in European Application No. 10726688.4 (REDCOM.007QEP), dated July 14, 2014.	
	305	POYNTON, Charles, "A Technical Introduction to Digital Video," 1996, Ch. 6 (Gamma), pp. 91-114.	

18876617

Examiner Signature	/Trung Diep/	Date Considered	11/10/2014
--------------------	--------------	-----------------	------------

***Examiner:** Initial if reference considered, whether or not citation is in conformance with MPEP 609. Draw line through citation if not in conformance and not considered. Include copy of this form with next communication to applicant.

T¹ - Place a check mark in this area when an English language translation is attached. **ALL REFERENCES CONSIDERED EXCEPT WHERE LINED THROUGH. /T.D./**

Please Direct All Correspondence to Customer Number 20995

RESPONSE TO INFORMATIONAL NOTICE

Inventor	:	James H. Jannard
App. No.	:	14/485612
Filed	:	September 12, 2014
For	:	VIDEO CAMERA
Art Unit	:	2664
Conf No.	:	1068

**Commissioner for Patents
P.O. Box 1450
Alexandria, VA 22313-1450**

Dear Sir:

The above-captioned application was filed without a Declaration and/or Substitute Statement. Enclosed in compliance with 37 CFR 1.53(f) are the following.

(X) Declaration(s) for:

James H. Jannard
Thomas Graeme Nattress

The Commissioner is hereby authorized to charge any additional fees which may be required, now or in the future, or credit any overpayment, to Account No. 11-1410.

/Sean Ambrosius/
Sean Ambrosius
Registration No. 65,290
Attorney of Record
Customer No. 20995
(949) 760-0404

19234708

DECLARATION (37 CFR 1.63) FOR UTILITY OR DESIGN APPLICATION USING AN APPLICATION DATA SHEET (37 CFR 1.76)

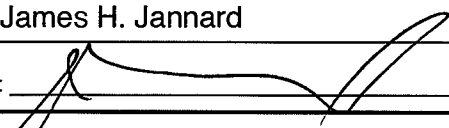
Title of Invention	VIDEO CAMERA
<p>As the below named inventor, I hereby declare that:</p> <p>This declaration is directed to: <input type="checkbox"/> The attached application, or <input checked="" type="checkbox"/> United States application or PCT international application number <u>14/485612</u> filed on <u>September 12, 2014</u>.</p> <p>The above-identified application was made or authorized to be made by me.</p> <p>I believe that I am the original inventor or an original joint inventor of a claimed invention in the application.</p> <p>I hereby acknowledge that any willful false statement made in this declaration is punishable under 18 U.S.C. 1001 by fine or imprisonment of not more than five (5) years, or both.</p> <p style="text-align: center;">WARNING:</p> <p>Petitioner/applicant is cautioned to avoid submitting personal information in documents filed in a patent application that may contribute to identity theft. Personal information such as social security numbers, bank account numbers, or credit card numbers (other than a check or credit card authorization form PTO-2038 submitted for payment purposes) is never required by the USPTO to support a petition or an application. If this type of personal information is included in documents submitted to the USPTO, petitioners/applicants should consider redacting such personal information from the documents before submitting them to the USPTO. Petitioner/applicant is advised that the record of a patent application is available to the public after publication of the application (unless a non-publication request in compliance with 37 CFR 1.213(a) is made in the application) or issuance of a patent. Furthermore, the record from an abandoned application may also be available to the public if the application is referenced in a published application or an issued patent (see 37 CFR 1.14). Checks and credit card authorization forms PTO-2038 submitted for payment purposes are not retained in the application file and therefore are not publicly available.</p>	
<p>LEGAL NAME OF INVENTOR</p> <p>Inventor: <u>James H. Jannard</u> Date (Optional) : _____</p> <p>Signature:  _____</p>	
<p><small>Note: An application data sheet (PTO/SB/14 or equivalent), including naming the entire inventive entity, must accompany this form or must have been previously filed. Use an additional PTO/AIA/01 form for each additional inventor.</small></p>	

This collection of information is required by 35 U.S.C. 115 and 37 CFR 1.63. The information is required to obtain or retain a benefit by the public which is to file (and by the USPTO to process) an application. Confidentiality is governed by 35 U.S.C. 122 and 37 CFR 1.11 and 1.14. This collection is estimated to take 1 minute to complete, including gathering, preparing, and submitting the completed application form to the USPTO. Time will vary depending upon the individual case. Any comments on the amount of time you require to complete this form and/or suggestions for reducing this burden, should be sent to the Chief Information Officer, U.S. Patent and Trademark Office, U.S. Department of Commerce, P.O. Box 1450, Alexandria, VA 22313-1450. DO NOT SEND FEES OR COMPLETED FORMS TO THIS ADDRESS. **SEND TO: Commissioner for Patents, P.O. Box 1450, Alexandria, VA 22313-1450.**

If you need assistance in completing the form, call 1-800-PTO-9199 and select option 2.

Under the Paperwork Reduction Act of 1995, no persons are required to respond to a collection of information unless it displays a valid OMB control number.

DECLARATION (37 CFR 1.63) FOR UTILITY OR DESIGN APPLICATION USING AN APPLICATION DATA SHEET (37 CFR 1.76)

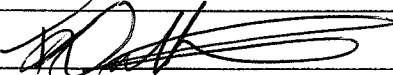
Title of Invention	VIDEO CAMERA
<p>As the below named inventor, I hereby declare that:</p> <p>This declaration is directed to: <input type="checkbox"/> The attached application, or <input checked="" type="checkbox"/> United States application or PCT international application number <u>14/485612</u> filed on <u>September 12, 2014</u>.</p> <p>The above-identified application was made or authorized to be made by me.</p> <p>I believe that I am the original inventor or an original joint inventor of a claimed invention in the application.</p> <p>I hereby acknowledge that any willful false statement made in this declaration is punishable under 18 U.S.C. 1001 by fine or imprisonment of not more than five (5) years, or both.</p> <p style="text-align: center;">WARNING:</p> <p>Petitioner/applicant is cautioned to avoid submitting personal information in documents filed in a patent application that may contribute to identity theft. Personal information such as social security numbers, bank account numbers, or credit card numbers (other than a check or credit card authorization form PTO-2038 submitted for payment purposes) is never required by the USPTO to support a petition or an application. If this type of personal information is included in documents submitted to the USPTO, petitioners/applicants should consider redacting such personal information from the documents before submitting them to the USPTO. Petitioner/applicant is advised that the record of a patent application is available to the public after publication of the application (unless a non-publication request in compliance with 37 CFR 1.213(a) is made in the application) or issuance of a patent. Furthermore, the record from an abandoned application may also be available to the public if the application is referenced in a published application or an issued patent (see 37 CFR 1.14). Checks and credit card authorization forms PTO-2038 submitted for payment purposes are not retained in the application file and therefore are not publicly available.</p>	
<p>LEGAL NAME OF INVENTOR</p> <p>Inventor: <u>Thomas Graeme Nattress</u> Date (Optional): <u>16th October 2014</u></p> <p>Signature: </p>	
<p>Note: An application data sheet (PTO/SB/14 or equivalent), including naming the entire inventive entity, must accompany this form or must have been previously filed. Use an additional PTO/AIA/01 form for each additional inventor.</p>	

This collection of information is required by 35 U.S.C. 115 and 37 CFR 1.63. The information is required to obtain or retain a benefit by the public which is to file (and by the USPTO to process) an application. Confidentiality is governed by 35 U.S.C. 122 and 37 CFR 1.11 and 1.14. This collection is estimated to take 1 minute to complete, including gathering, preparing, and submitting the completed application form to the USPTO. Time will vary depending upon the individual case. Any comments on the amount of time you require to complete this form and/or suggestions for reducing this burden, should be sent to the Chief Information Officer, U.S. Patent and Trademark Office, U.S. Department of Commerce, P.O. Box 1450, Alexandria, VA 22313-1450. DO NOT SEND FEES OR COMPLETED FORMS TO THIS ADDRESS. **SEND TO: Commissioner for Patents, P.O. Box 1450, Alexandria, VA 22313-1450.**

If you need assistance in completing the form, call 1-800-PTO-9199 and select option 2.

Electronic Acknowledgement Receipt

EFS ID:	20839202
Application Number:	14485612
International Application Number:	
Confirmation Number:	1068
Title of Invention:	VIDEO CAMERA
First Named Inventor/Applicant Name:	James H. Jannard
Customer Number:	20995
Filer:	Sean Patrick Ambrosius/Christine Showalter
Filer Authorized By:	Sean Patrick Ambrosius
Attorney Docket Number:	REDCOM.007C4
Receipt Date:	02-DEC-2014
Filing Date:	12-SEP-2014
Time Stamp:	13:24:38
Application Type:	Utility under 35 USC 111(a)

Payment information:

Submitted with Payment	no
------------------------	----

File Listing:

Document Number	Document Description	File Name	File Size(Bytes)/ Message Digest	Multi Part /.zip	Pages (if appl.)
1	Transmittal Letter	REDCOM-007C4_Transmittal.pdf	14429 <small>38c6b1ef6c71f53bb6eb1fe4c87904601062c26e</small>	no	1

Warnings:

Information:

2	Oath or Declaration filed	REDCOM-007C4_Decs.pdf	149935	no	2
			a6d20163052773e1e824f208af7756ffd61d596c		

Warnings:

Information:

Total Files Size (in bytes):	164364
-------------------------------------	--------

This Acknowledgement Receipt evidences receipt on the noted date by the USPTO of the indicated documents, characterized by the applicant, and including page counts, where applicable. It serves as evidence of receipt similar to a Post Card, as described in MPEP 503.

New Applications Under 35 U.S.C. 111

If a new application is being filed and the application includes the necessary components for a filing date (see 37 CFR 1.53(b)-(d) and MPEP 506), a Filing Receipt (37 CFR 1.54) will be issued in due course and the date shown on this Acknowledgement Receipt will establish the filing date of the application.

National Stage of an International Application under 35 U.S.C. 371

If a timely submission to enter the national stage of an international application is compliant with the conditions of 35 U.S.C. 371 and other applicable requirements a Form PCT/DO/EO/903 indicating acceptance of the application as a national stage submission under 35 U.S.C. 371 will be issued in addition to the Filing Receipt, in due course.

New International Application Filed with the USPTO as a Receiving Office

If a new international application is being filed and the international application includes the necessary components for an international filing date (see PCT Article 11 and MPEP 1810), a Notification of the International Application Number and of the International Filing Date (Form PCT/RO/105) will be issued in due course, subject to prescriptions concerning national security, and the date shown on this Acknowledgement Receipt will establish the international filing date of the application.



UNITED STATES PATENT AND TRADEMARK OFFICE

UNITED STATES DEPARTMENT OF COMMERCE
United States Patent and Trademark Office
Address: COMMISSIONER FOR PATENTS
P.O. Box 1450
Alexandria, Virginia 22313-1450
www.uspto.gov

Table with 4 columns: APPLICATION NUMBER (14/485,612), FILING OR 371(C) DATE (09/12/2014), FIRST NAMED APPLICANT (James H. Jannard), ATTY. DOCKET NO./TITLE (REDCOM.007C4)

CONFIRMATION NO. 1068

PUBLICATION NOTICE

20995
KNOBBE MARTENS OLSON & BEAR LLP
2040 MAIN STREET
FOURTEENTH FLOOR
IRVINE, CA 92614



Title:VIDEO CAMERA

Publication No.US-2015-0002695-A1
Publication Date:01/01/2015

NOTICE OF PUBLICATION OF APPLICATION

The above-identified application will be electronically published as a patent application publication pursuant to 37 CFR 1.211, et seq. The patent application publication number and publication date are set forth above.

The publication may be accessed through the USPTO's publically available Searchable Databases via the Internet at www.uspto.gov. The direct link to access the publication is currently http://www.uspto.gov/patft/.

The publication process established by the Office does not provide for mailing a copy of the publication to applicant. A copy of the publication may be obtained from the Office upon payment of the appropriate fee set forth in 37 CFR 1.19(a)(1). Orders for copies of patent application publications are handled by the USPTO's Office of Public Records. The Office of Public Records can be reached by telephone at (703) 308-9726 or (800) 972-6382, by facsimile at (703) 305-8759, by mail addressed to the United States Patent and Trademark Office, Office of Public Records, Alexandria, VA 22313-1450 or via the Internet.

In addition, information on the status of the application, including the mailing date of Office actions and the dates of receipt of correspondence filed in the Office, may also be accessed via the Internet through the Patent Electronic Business Center at www.uspto.gov using the public side of the Patent Application Information and Retrieval (PAIR) system. The direct link to access this status information is currently http://pair.uspto.gov/. Prior to publication, such status information is confidential and may only be obtained by applicant using the private side of PAIR.

Further assistance in electronically accessing the publication, or about PAIR, is available by calling the Patent Electronic Business Center at 1-866-217-9197.

Office of Data Management, Application Assistance Unit (571) 272-4000, or (571) 272-4200, or 1-888-786-0101

IN THE UNITED STATES PATENT AND TRADEMARK OFFICE

Inventor	:	James H. Jannard
App. No.	:	14/485612
Filed	:	September 12, 2014
For	:	VIDEO CAMERA
Examiner	:	Diep, Trung T.
Art Unit	:	2664
Conf. No.	:	1068

RESPONSE TO NON-FINAL OFFICE ACTION**Mail Stop Amendment**

Commissioner for Patents

P.O. Box 1450

Alexandria, VA 22313-1450

Dear Sir:

In response to the pending Non-Final Office Action mailed November 17, 2014, Applicant respectfully submits the following amendments and comments.

Amendments to the Claims are reflected in the listing of claims which begins on page 2 of this paper.

Remarks begin on page 9 of this paper.

AMENDMENTS TO THE CLAIMS

1. (Original) A video camera comprising:
 - a portable housing having an opening through which light emanating from outside the portable housing enters the portable housing;
 - a memory device supported by the portable housing;
 - an image sensor comprising first, second, and third pluralities of light sensitive devices arranged with respect to one another in a plane defined by the image sensor such that the first, second, and third pluralities of light sensitive devices are intermingled, defining an intermingled pattern, the first, second, and third pluralities of light sensitive devices being configured to detect first, second, and third colors, respectively, the first, second, and third colors being different from each other, the image sensor being configured to convert light entering the portable housing through the opening into raw mosaiced image data comprising one data value for each of the light sensitive devices included in the first, second, and third pluralities of light sensitive devices, the image sensor being configured to output the raw mosaiced image data at a resolution of at least 2k and at a frame rate of at least about 23 frames per second; and
 - electronics having an image processing module and a compression module implemented therein,
 - the image processing module connected between the image sensor and the memory device, the image processing module configured to process the raw mosaiced image data from the image sensor and output processed image data based on the raw mosaiced image data from the image sensor, the processed image data including less than three data values for each of the light sensitive devices included in the first, second, and third pluralities of light sensitive devices, and
 - the compression module connected between the image sensor and the memory device, the compression module configured to compress the processed image data with a mathematically lossy compression technique into compressed processed image data such that the compressed processed image data can be decompressed and demosaiced into a substantially visually lossless image of at least 2k resolution,

wherein the memory device receives the compressed processed image data at a rate of at least about 23 frames per second.

2. (Original) A video camera according to claim 1 wherein the image sensor is configured to output the raw mosaiced image data at a resolution of at least 2k and at a frame rate of at least 23 frames per second, wherein the compressed processed image data can be decompressed and demosaiced into a visually lossless image of at least 2k resolution, and wherein the memory device receives the compressed processed image data at a rate of at least 23 frames per second.

3. (Original) A video camera according to claim 1 wherein the image sensor is configured to output the raw mosaiced image data at a resolution of at least 4k, and the compressed processed image data can be decompressed and demosaiced into a substantially visually lossless image of at least 4k resolution.

4. (Original) A video camera according to claim 1 wherein the image sensor is configured to output the raw mosaiced image data at a resolution of at least 4k and at a frame rate of at least 23 frames per second, wherein the compressed processed image data can be decompressed and demosaiced into a visually lossless image of at least 4k resolution, and wherein the memory device receives the compressed processed image data at a rate of at least 23 frames per second.

5. (Original) A video camera according to claim 1 wherein the one data value for each of the first plurality of light sensitive devices is representative of light of only the first color, the one data value for each of the second plurality of light sensitive devices is representative of light of only the second color, and the one data value for each of the third plurality of light sensitive devices is representative of only the third color, and wherein the processed image data does not include separate data values for the first, second, and third colors for each of the light sensitive devices.

6. (Original) A video camera according to claim 1 wherein the memory device is disposed within the portable housing.

7. (Original) A video camera according to claim 1 wherein the memory device is supported on the outside of the portable housing.

8. (Original) A video camera according to claim 1 additionally comprising a playback module configured to receive the compressed processed image data from the memory device, and decompress and demosaic the compressed processed image data into demosaiced image data that includes three data values for each of the light sensitive devices included in the first, second, and third pluralities of light sensitive devices.

9. (Original) A video camera according to claim 1 wherein the compression module comprises a compression chip.

10. (Original) A video camera according to claim 1 wherein the compression technique is a wavelet compression technique.

11. (Original) A video camera according to claim 1 wherein the image processing module is configured to process the raw mosaiced image data at least in part by applying a pre-emphasis function to the raw mosaiced image data, wherein the pre-emphasis function is configured to increase data values of the mosaiced image data corresponding to relatively dark image regions and to decrease data values of the mosaiced image data corresponding to relatively bright image regions.

12. (Original) A video camera according to claim 1 wherein the image sensor is configured to output the raw mosaiced image data at a resolution falling within a range between and inclusive of 2k and 4.5k and at a frame rate falling within a range between and inclusive of 23 and 120 frames per second, wherein the compression module is configured to compress the processed image data with a mathematically lossy compression technique into compressed processed image data such that the compressed processed image data can be decompressed and demosaiced into a substantially visually lossless image having a resolution falling within a range between and inclusive of 2k and 4.5k resolution, and wherein the memory device receives the compressed processed image data at a rate falling within a range between and inclusive of 23 frames per second and 120 frames per second.

13. (Original) A video camera according to claim 1 wherein the image sensor is configured to output the raw mosaiced image data at a resolution that is one of 2k, 4k, and 4.5k and at a frame rate falling within a range between and inclusive of 23 and 120 frames per second, wherein the compression module is configured to compress the processed image data with a mathematically lossy compression technique into compressed processed image data such that the

compressed processed image data can be decompressed and demosaiced into a substantially visually lossless image having a resolution that is one of 2k, 4k, and 4.5k, and wherein the memory device receives the compressed processed image data at a rate falling within a range between and inclusive of 23 frames per second and 120 frames per second.

14. (Original) A video camera according to claim 1 wherein the memory device is sufficiently large to store image data from the compression module corresponding to at least about 30 minutes of video at 12 mega pixel resolution, 12-bit color resolution, and at 60 frames per second.

15. (Original) A video camera according to claim 1 wherein the image sensor is a CMOS sensor.

16. (Currently Amended) A method of recording motion video with a camera, the method comprising:

receiving light with an image sensor of a camera, the image sensor comprising first, second, and third pluralities of light sensitive devices arranged with respect to one another in a plane defined by the image sensor such that the first, second, and third pluralities of light sensitive devices are intermingled, defining an intermingled pattern, the first, second, and third pluralities of light sensitive devices being configured to detect first, second, and third colors, respectively, the first, second, and third colors being different from each other;

converting the light received by the image sensor into mosaiced image data at a resolution of at least 2k and at a frame rate of at least about 23 frames per second, the mosaiced image data comprising one data value for each of the light sensitive devices included in the first, second, and third pluralities of light sensitive devices;

with electronics of the camera, processing the mosaiced image data from the image sensor and outputting processed image data based on the mosaiced image data from the image sensor, the processed image data including less than three data values for each of the light sensitive devices included in the first, second, and third pluralities of light sensitive devices;

with electronics of the camera, compressing the processed image data with a mathematically lossy compression technique into compressed processed image data such

that the compressed processed image data can be decompressed and demosaiced into a substantially visually lossless image of at least 2k resolution; and

recording the compressed processed image data onto a memory device of the camera at a rate of at least about 23 frames per second.

17. (Currently Amended) A method according to claim 16 wherein said converting comprises converting the light received by the image sensor into mosaiced image data at a resolution of at least 2k and at a frame rate of at least 23 frames per second, wherein the compressed processed image data can be decompressed and demosaiced into a visually lossless image of at least 2k resolution, and wherein said recording comprises recording the compressed processed image data onto a memory device of the camera at a rate of at least 23 frames per second.

18. (Currently Amended) A method according to claim 16 wherein said converting comprises converting the light received by the image sensor into mosaiced image data at a resolution of at least 4k, and the compressed processed image data can be decompressed and demosaiced into a substantially visually lossless image of at least 4k resolution.

19. (Currently Amended) A method according to claim 16 wherein said converting comprises converting the light received by the image sensor into mosaiced image data at a resolution of at least 4k and at a frame rate of at least 23 frames per second, wherein the compressed processed image data can be decompressed and demosaiced into a visually lossless image of at least 4k resolution, and wherein said recording comprises recording the compressed processed image data onto a memory device of the camera at a rate of at least 23 frames per second.

20. (Original) A method according to claim 16 wherein the one data value for each of the first plurality of light sensitive devices is representative of light of only the first color, the one data value for each of the second plurality of light sensitive devices is representative of light of only the second color, and the one data value for each of the third plurality of light sensitive devices is representative of only the third color, and wherein the processed image data does not include separate data values for the first, second, and third colors for each of the light sensitive devices.

21. (Original) A method according to claim 16 wherein said recording comprises recording the compressed processed image data onto a memory device disposed within a portable housing of the camera.

22. (Original) A method according to claim 16 wherein said recording comprises recording the compressed processed image data onto a memory device supported on the outside of a portable housing of the camera.

23. (Original) A method according to claim 16 additionally comprising:
receiving the compressed processed image data from the memory device with a playback module implemented in the electronics of the camera; and
decompressing and demosaicing the compressed processed image data into demosaiced image data that includes three data values for each of the light sensitive devices included in the first, second, and third pluralities of light sensitive devices.

24. (Original) A method according to claim 16 wherein the electronics comprise a compression chip and said compressing is done using the compression chip.

25. (Original) A method according to claim 16 wherein the mosaiced image data is raw mosaiced image data.

26. (Original) A method according to claim 16 wherein the compression technique is a wavelet compression technique.

27. (Original) A method according to claim 16 wherein said processing the image data comprises processing the mosaiced image data at least in part by applying a pre-emphasis function to the mosaiced image data, wherein the application of the pre-emphasis function increases data values of the mosaiced image data corresponding to relatively dark image regions and decreases data values of the mosaiced image data corresponding to relatively bright image regions.

28. (Original) A method according to claim 16 wherein said converting comprises converting the light received by the image sensor into mosaiced image data at a resolution falling within a range between and inclusive of 2k and 4.5k and at a frame rate falling within a range between and inclusive of 23 and 120 frames per second, wherein said compressing comprises compressing the processed image data with a mathematically lossy compression technique into compressed processed image data such that the compressed processed image data can be decompressed and demosaiced into a substantially visually lossless image having a resolution

falling within a range between and inclusive of 2k and 4.5k resolution, and said recording comprises recording the compressed processed image data at a rate falling within a range between and inclusive of 23 frames per second and 120 frames per second.

29. (Original) A method according to claim 16 wherein said converting comprises converting the light received by the image sensor into mosaiced image data at a resolution that is one of 2k, 4k, and 4.5k and at a frame rate falling within a range between and inclusive of 23 and 120 frames per second, wherein said compressing comprises compressing the processed image data with a mathematically lossy compression technique into compressed processed image data such that the compressed processed image data can be decompressed and demosaiced into a substantially visually lossless image having a resolution that is one of 2k, 4k, and 4.5k, and said recording comprises recording the compressed processed image data at a rate falling within a range between and inclusive of 23 frames per second and 120 frames per second.

30. (Original) A method according to claim 16 wherein the memory device is sufficiently large to store image data from the compression module corresponding to at least about 30 minutes of video at 12 mega pixel resolution, 12-bit color resolution, and at 60 frames per second.

REMARKS

By way of summary, Claims 1-30 remain pending. By this response, Applicant is amending claims 16-19.

In response to the Office Action mailed on November 17, 2014, Applicant respectfully requests the Examiner to reconsider the above-captioned application in view of the foregoing amendments and the following remarks.

Summary of Issues Presented in Office Action

The Office Action includes objections to claims 16-19 for informalities. Applicant has amended these claims in the manner suggested by the Examiner in the Office Action. Applicant respectfully requests withdrawal of the objections.

The Office Action also sets forth rejections to claims 1-30 based as being unpatentable under 35 U.S.C. § 103 based on the combination of Ishii (U.S. Patent No. 7,898,575) and Newman (U.S. Pat. No. 8,014,597). Applicant respectfully traverses the rejections for the reasons set forth below.

Background Information Related to Claimed Technology

As Applicant has explained in filings in related (previously pending, now issued) patent applications (e.g., Response filed July 1, 2013, Control No. 90/012,550, now reexamined U.S. Patent No. 8,174,560), prior to 2007, cinematographic experts were skeptical that any digital camera recording in compressed formats could be acceptable in the high end portions of the video market. See, e.g., Response filed July 1, 2013, Control No. 90/012,550, pp. 27-31 (including citations to Declarations from Academy Award Winners Sir Peter Jackson, Don M. Burgess, and Steven Soderbergh filed concurrently therewith).

An aspect of at least one of the embodiments disclosed in the present Application includes the realization of cameras that can produce high-quality, compressed video recordings that are acceptable to the experts and consumers in the high end market segments (e.g., the major motion picture market). More specifically, cameras that can capture, compress and store raw or substantially raw video data having a resolution of at least about 2k at a frame rate of at least about 23 frames per second. See, e.g., Present Application, paragraph [0003]. Moreover, with regard to the cameras and methods recited in the currently pending claims, the video data is

compressed such that the data remains substantially visually lossless upon decompression. See, e.g., Present Application, paragraphs [0004], [0007].

The Proposed Ishii/Newman Combination Does Not Render the Claims Obvious

Ishii describes an image pickup device and image recording apparatus. As the Examiner appears to recognize in the Office Action, Ishii does not disclose certain claimed features. For instance, specifically with respect to claim 1, Ishii does not disclose at least “electronics having an image processing module and a compression module”, the “image processing module configured to process the raw mosaiced image data”, and the “compression module configured to compress the processed image data...such that the compressed processed image data can be decompressed and demosaiced into a substantially visually lossless image of at least 2k resolution”. For example, Ishii describes performing “Bayer interpolation” prior to compression.

Moreover, Ishii does not describe that “compressed processed image data can be decompressed and demosaiced into a substantially visually lossless image of at least 2k resolution, wherein the memory device receives the compressed processed image data at a rate of at least about 23 frames per second.”

The Office Action looks to Newman to cure the deficiencies of Ishii. However, given the teachings of Ishii, the proposed modified device would not have resulted in the claimed invention. Rather, Ishii describes a system that *separately compresses and records different regions of the image* (e.g., different quadrants) of the image.

As explained in greater detail below, *separately compressing image data corresponding to different image regions*, as taught by Ishii, would increase the likelihood of artifacts at the boundaries between the different regions after the separately compressed image data is re-combined and thus create additional challenges to achieving a substantially visually lossless result. As a result, the resulting image data generated by the proposed modified device of Ishii would not lead of one of ordinary skill in the art to conclude that such compressed video data could be decompressed and demosaiced into a “substantially visually lossless image”.

Moreover, Ishii itself suggests that separately compressing and/or recording different regions of an image would not have been practical at the time of the filing date of the present application for cinema quality recording, such as where “the compressed processed image data can be decompressed and demosaiced into a substantially visually lossless image of at least 2k

resolution, wherein the memory device receives the compressed processed image data at a rate of at least 23 frames per second.”

For instance, referring to Figure 23 of Ishii, Ishii teaches incorporating four separate recording devices 109a-109d onto a camera. At the claimed resolutions and frame rates, incorporating four separate recording devices supported by the camera would have increased the likelihood of errors when recording the data and retrieving the recorded data at the claimed resolutions and frame rates. Thus, one of skill in the art would have no reason to believe that the resulting image data could not be decompressed and demosaiced into a “substantially visually lossless image” at the claimed resolutions and frame rates.

Claim 1

The Office Action recognizes on page 5 that Ishii does not disclose or suggest certain features of claim 1. For instance, specifically with respect to claim 1, Ishii does not disclose at least:

electronics having an image processing module and a compression module implemented therein,

the image processing module connected between the image sensor and the memory device, *the image processing module configured to process the raw mosaiced image data from the image sensor and output processed image data based on the raw mosaiced image data from the image sensor, the processed image data including less than three data values for each of the light sensitive devices included in the first, second, and third pluralities of light sensitive devices,* and

the compression module connected between the image sensor and the memory device, the compression module configured to *compress the processed image data* with a mathematically lossy compression technique *into compressed processed image data such that the compressed processed image data can be decompressed and demosaiced into a substantially visually lossless image of at least 2k resolution,*

wherein the memory device receives the compressed processed image data at a rate of at least about 23 frames per second.

In contrast to the technique of claim 1, Ishii describes demosaicing image data prior to compression. This is made clear throughout Ishii in at least the following passages:

The image processing unit 104 *performs predetermined image processes such as Bayer interpolation* and color correction for the image dsignals that have been supplied by the sensor 103.

Ishii column 5, lines 38-41.

In the 4k image pickup mode, the sensor 103 supplies image signals of an image size of 4096×2160 so that the image processing unit 104 *performs the Bayer interpolation* and the color correction...

Ishii column 5, lines 53-56.

In the 2k image pickup mode, the sensor 103 supplies image signals of an image size of 3072×1620 so that the image processing unit 104 *performs the Bayer interpolation* and the color correction...

Ishii column 5, lines 59-62.

In the 720 p image pickup mode, the sensor 103 supplies image signals of an image size of 1920×1080 so that the image processing unit 104 *performs the Bayer interpolation* and the color correction...

Ishii column 5, lines 64-67.

One of ordinary skill in the art understands that the term “interpolation” is often used in reference to demosaicing process. Moreover, it is also known that functions including color correction **can only be performed on demosaiced data**.

In light of the above-described reasons, the Patent Owner submits that one of ordinary skill in the art would conclude that Ishii reference is written with the assumption that the reader would understand that the well-known technique of demosaicing would necessarily be performed prior to compression.

As such, Ishii does not teach or suggest a system configured to “compress the processed image data with a mathematically lossy compression technique into compressed processed image data *such that the compressed processed image data can be* decompressed and *demosaiced* into a substantially visually lossless image of at least 2k resolution.”

The Office Action looks to Newman to cure certain deficiencies of Ishii, and suggests that one of skill in the art would have had a reason to modify the Ishii device in view of Newman to arrive at the video camera of claim 1. Applicant submits that this conclusion is incorrect. Rather, for the reasons set forth below, in view of the teachings of Ishii there is no reason at all to modify the Ishii device in the proposed manner. Indeed, the proposed modified device would not result in the claimed invention.

Ishii describes a technique of separately compressing and recording different regions of an image. Figure 7A of Ishii reproduced below illustrates a camera that implements such a process for a “4k image pickup mode”.

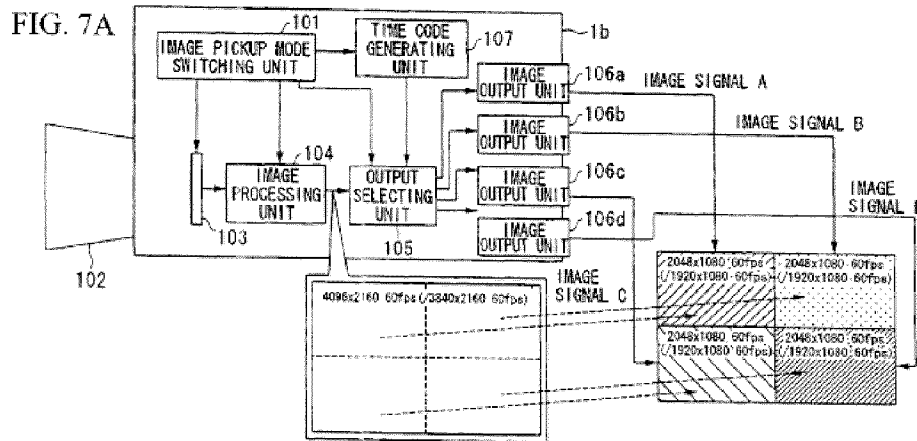

Ishii describes that the image processing unit 104 performs predetermined image processes such as Bayer interpolation and color correction, and “divides the image signal for each frame into four divided sets of image signals, and supplies the four sets of the divided image signals to the output selecting unit 105.” *Ishii, column 5, lines 38-67 and column 8, lines 13-28.* As shown in Figure 7A, each of the four sets of divided image signals correspond to one quadrant of the image. Notably, every single one of the 12 illustrated cameras in the Ishii reference shows separation of the image data into four divided sets of output signals, including the cameras illustrated in each of Figures 1, 3, 4, 7A, 8A, 9A, 10, 14, 15, 19, 23, and 24.

Ishii only appears to describe compression of image data with respect to Figures 23 and 24. Figure 23 is reproduced below:

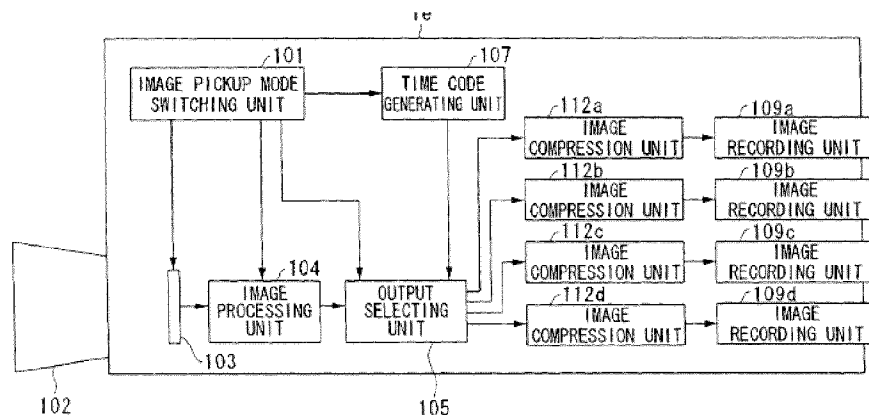

As shown, in the embodiment of Figure 23, the four divided image signals from output selecting unit 105 are sent to four separate image compression units 112a-112d and four separate image recording units 109a-109d. The same is true of the other embodiment capable of compressing image data shown in Figure 24.

Thus, any modified Ishii device would separate the image data into divided output signals, such as where the divided output signals correspond to different quadrants of the image data. However, separately compressing image data corresponding to different quadrants would result in significant visual artifacts when the quadrants are decompressed and re-combined. The artifacts would be particularly pronounced at the edges between quadrants. This is because with the known compression codecs used for video image data compression, the resulting decompressed value of one pixel is affected by the values of surrounding pixels during the compression process.

If quadrants are compressed separately in isolation from the other quadrants, the pixels at an edge of one quadrant will be compressed without taking into account pixels at the edge of the adjacent quadrant. As a result, modifying the camera of Ishii in the proposed manner would result in an increased likelihood of significant visual artifacts when the data is decompressed, demosaiced, and re-combined, especially at the seams between quadrants. This is especially true at the claimed resolutions because artifacts would be more visible for higher resolution image data than for lower resolution image data.

Ishii does not appear to make any reference to using the cameras disclosed in Ishii for cinema-grade recording, or to whether or not the compressed data remains visually lossless upon decompression. Thus, the above-described visual artifacts may have been acceptable for the purposes of the inventors of the Ishii device.

However, one of skill in the art would have had no reason to believe that the proposed modified Ishii device would produce image data that could be decompressed and demosaiced into a *substantially visually lossless* image of at least 2k resolution, wherein the memory device receives the compressed processed image data at a rate of at least about 23 frames per second.

Moreover, separately compressing and/or recording different regions of an image would not have been practical at the time of the filing date of the present application for cinema quality recording, such as where “the compressed processed image data can be decompressed and demosaiced into a substantially visually lossless image of at least 2k resolution, wherein the

memory device receives the compressed processed image data at a rate of at least 23 frames per second.” For instance, referring to Figure 23 of Ishii, Ishii teaches incorporating four separate recording devices 109a-109d onto a camera. At the claimed resolutions and frame rates, incorporating four separate recording devices supported by the camera would have significantly increased the likelihood of errors when recording the data and retrieving the recorded data at the claimed resolutions and frame rates, at least at the time of the filing date of the present application.

Thus, one of skill in the art would have had no reason to believe that the proposed modified Ishii device would produce image data that could be decompressed and demosaiced into a *substantially visually lossless* image of at least 2k resolution, wherein the memory device receives the compressed processed image data at a rate of at least about 23 frames per second.

For at least these reasons, the cited combination does not render the claims obvious. Applicant respectfully requests withdrawal of the rejection to claim 1.

Dependent Claims 2-15

Applicant submits that dependent claims 2-15 are patentably distinguished from the cited references at least based on their dependency from claim 1, for the reasons set forth above with respect to claim 1.

Independent Claim 16

Claim 16 is a method claim and is of different scope than claim 1, which is directed to a video camera. However, claim 16 shares certain similar features to claim 1, and is believed to be patentably distinguished from the cited references for reasons similar to those set forth above with respect to claim 1. Applicant submits that the cited references do not teach or suggest at least the following features of claim 16:

with electronics of the camera, compressing the processed image data with a mathematically lossy compression technique into compressed processed image data such that the compressed processed image data can be decompressed and demosaiced into a substantially visually lossless image of at least 2k resolution; and

recording the compressed processed image data onto a memory device of the camera at a rate of at least about 23 frames per second.

Application No.: 14/485612
Filing Date: September 12, 2014

Dependent Claims 17-30

Applicant submits that dependent claims 17-30 are patenatably distinguished from the cited references at least based on their dependency from claim 16, for the reasons set forth above with respect to claim 16.

No Disclaimers or Disavowals

Although the present communication may include alterations to the application or claims, or characterizations of claim scope or referenced art, Applicant is not conceding in this application that previously pending claims are not patentable over the cited references. Rather, any alterations or characterizations are being made to facilitate expeditious prosecution of this application. Applicant reserves the right to pursue at a later date any previously pending or other broader or narrower claims that capture any subject matter supported by the present disclosure, including subject matter found to be specifically disclaimed herein or by any prior prosecution. Accordingly, reviewers of this or any parent, child or related prosecution history shall not reasonably infer that Applicant has made any disclaimers or disavowals of any subject matter supported by the present application.

Co-Pending and Other Applications of Assignee

Applicant wishes to draw the Examiner's attention to the following applications of the present application's assignee, some of which are co-pending.

Docket No.	Serial No.	Patent/ Publication No.	Title	Filed
REDCOM.007A	12/101,882	8,174,560	VIDEO CAMERA	04/11/2008
REDCOM.007C1	13/464,803	2012/0294582	VIDEO CAMERA	05/04/2012
REDCOM.007C2	13/566,868	8,358,357	VIDEO CAMERA	08/03/2012
REDCOM.007C3	14/485,611	N/A	VIDEO CAMERA	09/12/2014
REDCOM.007CP1	12/422,507	8,237,830	VIDEO CAMERA	04/13/2009
REDCOM.007CP1C1	12/834,854	7,830,967	VIDEO CAMERA	07/12/2010
REDCOM.007CP1C2	13/566,924	2013/0113951	VIDEO CAMERA	08/03/2012
REDCOM.007P1C3	14/488,030	N/A	VIDEO CAMERA	09/16/2014

Application No.: 14/485612
Filing Date: September 12, 2014

Docket No.	Serial No.	Patent/ Publication No.	Title	Filed
REDCOM.007X1 (reexamination of REDCOM.007A)	90/012,550	8,174,560 C1	VIDEO CAMERA	09/13/2012

Applicant notes that cited references, office actions, responses and notices of allowance currently exist or will exist for the above-referenced matters. Applicant also understands that the Examiner has access to sophisticated online Patent Office computing systems that provide ready access to the full file histories of these matters including, for example, specifications, drawings, pending claims, cited art, office actions, responses, declarations, and notices of allowance. Rather than submit copies these file histories, Applicant respectfully requests that the Examiner continue to review these file histories online for past, current, and future information about these matters. Also, if the Examiner cannot readily access these file histories, the Applicant would be pleased to provide any portion of any of the file histories at any time upon specific Examiner request.

Please charge any additional fees, including any fees for additional extension of time, or credit overpayment to Deposit Account No. 11-1410.

Respectfully submitted,

KNOBBE, MARTENS, OLSON & BEAR, LLP

Dated: May 18, 2015

By: /Sean Ambrosius/ _____
Sean Ambrosius
Registration No. 65,290
Attorney of Record
Customer No. 20995
(949) 760-0404

19352044

COPY

REDCOM.007X1

PATENT

IN THE UNITED STATES PATENT AND TRADEMARK OFFICE

Applicant : James Jannard, et al.
Reexam Control No. : 90/012,550
Reexam Filed : September 13, 2012
Patent No. : 8,174,560
For : VIDEO CAMERA
Examiner : Henry N. Tran
Art Unit : 3992
Conf No. : 1159

CERTIFICATE OF EFS WEB TRANSMISSION

I hereby certify that this correspondence, and any other attachment noted on the automated Acknowledgement Receipt, is being transmitted from within the Pacific Time zone to the Commissioner for Patents via the EFS Web server on:

July 1, 2013

(Date)

/Michael Guiliiana/

Michael A. Guiliiana, Reg. no. 42,611

DECLARATION OF SIR PETER JACKSON UNDER 37 C.F.R. §1.132

Commissioner for Patents
P.O. Box 1450
Alexandria, VA 22313-1450

Dear Sir:

I, Sir Peter Jackson, declare that:

1. I am a professional film maker and have served as Producer, Director, and Writer, in various capacities in my projects. My filmography is attached as Exhibit A. Exhibit B includes a list of awards and nominations I have received.

2. In my experience with various productions, I have personally used and directed the use of cameras made by Red.com, Inc., ("RED").

3. I believe I was the first person to direct a film that was shot using one of RED's cameras, back in 2007. That camera, a pre-production version of RED's RED ONE, had the ability to record, onboard, compressed raw image data, at 2K and higher resolutions, yet remain visually lossless. Specifically, the RED ONE camera could compress and record raw digital image data having a resolution of at least 2K (including 4K) into a storage device of the camera (e.g., carried on or within a portable housing of the camera) at a frame rate of at least about twenty-three

Control No.: 90/012,550
Patent No.: 8,174,560

frames per second. The RED ONE camera compressed the raw digital image data such that the data remained substantially visually lossless upon decompression.

4. The film "Crossing the Line" was a test made with RED's cameras that were then in development. The camera was unlike anything we had ever seen before in camera technology. In fact to my knowledge it has only been in the past year that other compressed raw camera systems have come to market; over six years since I first used the RED ONE.

5. RED's innovation was an idea not seen before in cinema production. Without this breakthrough, the data requirements for shooting high-resolution cinema would not be feasible. RED's method of compressing and recording raw digital image data having a resolution of at least 2K (including 4K) into a storage device of the camera (e.g., carried on or within a portable housing of the camera) at a frame rate of at least about twenty-three frames per second, where the data remains substantially visually lossless upon decompression, has allowed us, as an industry, to push forward with higher resolutions that improve picture quality. When shooting, I use both the 2K and 4K modes; the 4k mode for normal speed shooting and the 2k mode for slow motion shooting. Switching to the 2K mode lowers the data rate that would normally result from shooting at a higher frame rate needed for achieving a slow motion effect.

6. Previous (non-compressed raw) methods of recording digital motion pictures were not satisfactory alternatives to film-based production because they were more expensive, of lower picture quality and ironically had higher data requirements.

7. On The Hobbit films I have shot over four times the amount of footage as I did ten years ago on The Lord of the Rings trilogy. This has only been possible due to the RED's invention of the compressed raw system. Uncompressed files would have resulted in an impossible amount of data for our system to handle.

8. More recently, I have moved into even higher frame rates for normal speed shooting. The Hobbit movies were shot in 3D at 48 frames per second, twice the usual frame rate for cinema. This too was an innovation only made possible by the RED's compressed raw system. There was no other camera system that could do that when we started shooting The Hobbit.

Control No.: 90/012,550
Patent No.: 8,174,560

9. I have no hesitation in saying that RED's compressed raw system is a first of its kind system that has pushed the film industry forward and allowed us to do things not previously possible.

10. My continued reliance on RED cameras is based primarily on the ability of the RED cameras to compress and record raw digital image data having a resolution of at least 2K (including 4K) into a storage device of the camera (e.g., carried on or within a portable housing of the camera) at a frame rate of at least about twenty-three frames per second, where the data remains substantially visually lossless upon decompression. This decision is not based on any competitive price comparisons or advertising.

11. All statements made herein of my own knowledge are true. All statements made on information and belief are believed to be true. These statements were made with the knowledge that willful false statements and the like so made are punishable by fine, imprisonment, or both, under 18 U.S.C. § 1001, and that such willful false statements may jeopardize the validity of the application or any patent issuing therefrom.

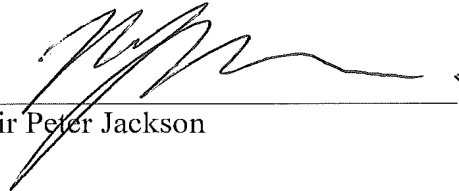

Sir Peter Jackson

24 June 2013

Date

15329107
050113

Control No.: 90/012,550
Patent No.: 8,174,560

EXHIBIT A

Filmography

Year	Title of Movie	Job
1976	The Valley (short)	Director, Writer, Producer
1987	Bad Taste	Director, Writer, Producer
1989	Meet the Feebles	Director, Writer, Producer
1992	Valley of the Stereos (short)	Producer
1992	Braindead (Dead Alive)	Director, Writer
1994	Heavenly Creatures	Director, Writer, Producer
1995	Forgotten Silver	Director, Writer
1996	Jack Brown Genius	Writer, Producer
1996	The Frighteners	Director, Writer, Producer
2001	The Lord of the Rings: The Fellowship of the Ring	Director, Writer, Producer
2002	The Lord of The Rings: The Two Towers	Director, Writer, Producer
2003	The Lord of the Rings: The Return of the King	Director, Writer, Producer
2003	The Long and Short of It (short)	Executive Producer
2005	King Kong	Director, Writer, Producer
2008	Crossing the Line (short)	Director, Writer
2009	District 9	Producer
2009	The Lovely Bones	Director, Writer, Producer
2011	The Adventures of Tintin: The Secret of the Unicorn	Producer
2012	West of Memphis	Producer
2012	The Hobbit: An Unexpected Journey	Director, Writer, Producer
2013	The Hobbit: The Desolation of Smaug	Director, Writer, Producer
2014	The Hobbit: There and Back Again	Director, Writer, Producer
2015	The Adventures of Tintin sequel	Director, Producer

Control No.: 90/012,550
Patent No.: 8,174,560

EXHIBIT B

Awards

AFI Awards, USA, 2002

- Won, AFI Award for Movie of the Year for The Lord of the Rings: The Fellowship of the Ring (2001) - Shared With: Barrie M. Osborne, Fran Walsh, Tim Sanders
- THE LORD OF THE RINGS: THE FELLOWSHIP OF THE RING taps the magical forces of American film to bring life to J.R.R. Tolkien's rich literary legacy. Never losing sight of the "human" elements of this first book in his trilogy, the scope of the film sets the standard by which future motion picture epics should be judged.

Academy Awards, USA, 2010

- Nominated, Oscar for Best Motion Picture of the Year for District 9 (2009) - Shared With Carolynne Cunningham

Academy Awards, USA, 2004

- Won, Oscar for Best Picture for The Lord of the Rings: The Return of the King (2003) - Shared With Barrie M. Osborne, Fran Walsh
- Won, Oscar for Best Director for The Lord of the Rings: The Return of the King (2003)
- Won, Oscar for Best Writing, Adapted Screenplay for The Lord of the Rings: The Return of the King (2003) - Shared With Fran Walsh, Philippa Boyens

Academy Awards, USA, 2003

- Nominated, Oscar for Best Picture for The Lord of the Rings: The Two Towers (2002) - Shared With Barrie M. Osborne, Fran Walsh

Academy Awards, USA, 2002

- Nominated, Oscar for Best Picture for The Lord of the Rings: The Fellowship of the Ring (2001) - Shared With Barrie M. Osborne, Fran Walsh
- Nominated, Oscar for Best Director for The Lord of the Rings: The Fellowship of the Ring (2001)
- Nominated, Oscar for Best Writing, Screenplay Based on Material Previously Produced or Published for The Lord of the Rings: The Fellowship of the Ring (2001) - Shared With Fran Walsh, Philippa Boyens

Academy Awards, USA, 1995

- Nominated, Oscar for Best Writing, Screenplay Written Directly for the Screen for Heavenly Creatures (1994) - Shared With Fran Walsh

Academy of Science Fiction, Fantasy & Horror Films, USA, 2013

- Nominated, Saturn Award for Best Director for The Hobbit: An Unexpected Journey (2012)

Control No.: 90/012,550
Patent No.: 8,174,560

Academy of Science Fiction, Fantasy & Horror Films, USA, 2006

- Won, Saturn Award for Best Director for King Kong (2005)
- Nominated, Saturn Award for Best Writing for King Kong (2005) - Shared With Fran Walsh, Philippa Boyens

Academy of Science Fiction, Fantasy & Horror Films, USA, 2004

- Won, Saturn Award for Best Director for The Lord of the Rings: The Return of the King (2003)
- Won, Saturn Award for Best Writing for The Lord of the Rings: The Return of the King (2003)
- Shared With Fran Walsh, Philippa Boyens

Academy of Science Fiction, Fantasy & Horror Films, USA, 2003

- Nominated, Saturn Award for Best Director for The Lord of the Rings: The Two Towers (2002)
- Nominated, Saturn Award for Best Writing for The Lord of the Rings: The Two Towers (2002)
- Shared With Fran Walsh, Philippa Boyens, Stephen Sinclair

Academy of Science Fiction, Fantasy & Horror Films, USA, 2002

- Won, Saturn Award for Best Director for The Lord of the Rings: The Fellowship of the Ring (2001)
- Nominated, Saturn Award for Best Writing for The Lord of the Rings: The Fellowship of the Ring (2001) - Shared With Fran Walsh, Philippa Boyens

Academy of Science Fiction, Fantasy & Horror Films, USA, 1997

- Nominated, Saturn Award for Best Director for The Frighteners (1996)
- Nominated, Saturn Award for Best Writer for The Frighteners (1996) - Shared With Fran Walsh

Amanda Awards, Norway, 2004

- Won, Amanda for Best Foreign Feature Film (Årets utenlandske kinofilm) for The Lord of the Rings: The Return of the King (2003)

Amanda Awards, Norway, 2003

- Nominated, Amanda for Best Foreign Feature Film (Årets utenlandske spillefilm) for The Lord of the Rings: The Two Towers (2002)

Amanda Awards, Norway, 2002

- Nominated, Amanda for Best Foreign Feature Film (Årets utenlandske spillefilm) for The Lord of the Rings: The Fellowship of the Ring (2001)

Amsterdam Fantastic Film Festival, 2004

- Won, Lifetime Achievement Award

Amsterdam Fantastic Film Festival, 1993

- Won, Silver Scream Award for Dead Alive (1992)

Control No.: 90/012,550
Patent No.: 8,174,560

Australian Film Institute, 2004

- Won, AFI Award for Best Foreign Film for The Lord of the Rings: The Return of the King (2003) - Shared With Barrie M. Osborne, Fran Walsh

Australian Film Institute, 2003

- Won, Best Foreign Film Award for The Lord of the Rings: The Two Towers (2002) - Shared With Barrie M. Osborne, Fran Walsh

Australian Film Institute, 2002

- Won, Best Foreign Film Award for The Lord of the Rings: The Fellowship of the Ring (2001) - Shared With Barrie M. Osborne, Fran Walsh, Tim Sanders

Avoriaz Fantastic Film Festival, 1993

- Won, Grand Prize for Dead Alive (1992)

BAFTA Awards, 2004

- Won, BAFTA Film Award for Best Film for The Lord of the Rings: The Return of the King (2003) - Shared With Barrie M. Osborne, Fran Walsh
- Won, BAFTA Film Award for Best Screenplay - Adapted for The Lord of the Rings: The Return of the King (2003) - Shared With Fran Walsh, Philippa Boyens
- Nominated, David Lean Award for Direction for The Lord of the Rings: The Return of the King (2003)
- Nominated, BAFTA Children's Award for Best Feature Film for The Lord of the Rings: The Return of the King (2003) - Shared With Fran Walsh, Barrie M. Osborne

BAFTA Awards, 2003

- Nominated, BAFTA Children's Award for Best Feature Film for The Lord of the Rings: The Two Towers (2002) - Shared With Barrie M. Osborne, Fran Walsh
- Nominated, BAFTA Film Award for Best Film for The Lord of the Rings: The Two Towers (2002) - Shared With Barrie M. Osborne, Fran Walsh
- Nominated, David Lean Award for Direction for The Lord of the Rings: The Two Towers (2002)

BAFTA Awards, 2002

- Won, BAFTA Film Award for Best Film for The Lord of the Rings: The Fellowship of the Ring (2001) - Shared With Barrie M. Osborne, Tim Sanders
- Won, David Lean Award for Direction for The Lord of the Rings: The Fellowship of the Ring (2001)
- Nominated, BAFTA Children's Award for Best Feature Film for The Lord of the Rings: The Fellowship of the Ring (2001) - Shared With Barrie M. Osborne, Fran Walsh, Tim Sanders
- Nominated, BAFTA Film Award for Best Screenplay - Adapted for The Lord of the Rings: The Fellowship of the Ring (2001) - Shared With Fran Walsh, Philippa Boyens

Control No.: 90/012,550
Patent No.: 8,174,560

Bodil Awards, 2004

- Nominated, Bodil for Best American Film (Bedste amerikanske film) for The Lord of the Rings: The Return of the King (2003)

Bodil Awards, 2002

- Won, Bodil for Best American Film (Bedste amerikanske film) for The Lord of the Rings: The Fellowship of the Ring (2001)

Boston Society of Film Critics Awards, 2003

- 2nd place, BSFC Award for Best Director for The Lord of the Rings: The Return of the King (2003)

Boston Society of Film Critics Awards, 2001

- 2nd place, BSFC Award for Best Director for The Lord of the Rings: The Fellowship of the Ring (2001)

Bram Stoker Awards, 2002

- Nominated, Bram Stoker Award for Screenplay for The Lord of the Rings: The Fellowship of the Ring (2001) - Shared With Philippa Boyens, Fran Walsh

Broadcast Film Critics Association Awards, 2006

- Nominated, Critics Choice Award for Best Director for King Kong (2005)

Broadcast Film Critics Association Awards, 2004

- Won, Critics Choice Award for Best Director for The Lord of the Rings: The Return of the King (2003)

Broadcast Film Critics Association Awards, 2002

- Nominated, Critics Choice Award for Best Director for The Lord of the Rings: The Fellowship of the Ring (2001)

Central Ohio Film Critics Association, 2004

- Won, COFCA Award for Best Director for The Lord of the Rings: The Return of the King (2003)
- 2nd place, COFCA Award for Best Screenplay, Adapted for The Lord of the Rings: The Return of the King (2003) - Shared With Philippa Boyens, Fran Walsh

Chicago Film Critics Association Awards, 2006

- Nominated, CFCA Award for Best Director for King Kong (2005)

Chicago Film Critics Association Awards, 2004

- Won, CFCA Award for Best Director for The Lord of the Rings: The Return of the King (2003)
- Nominated, CFCA Award for Best Screenplay for The Lord of the Rings: The Return of the King (2003) - Shared With Fran Walsh, Philippa Boyens

Chicago Film Critics Association Awards, 2003

Control No.: 90/012,550
Patent No.: 8,174,560

- Nominated, CFCA Award for Best Director for The Lord of the Rings: The Two Towers (2002)

Chicago Film Critics Association Awards, 2002

- Nominated, CFCA Award for Best Director for The Lord of the Rings: The Fellowship of the Ring (2001)

Chicago International Film Festival, 1996

- Nominated, Gold Hugo for Best Documentary for Forgotten Silver (1995)

Chicago International Film Festival, 1994

- Nominated, Gold Hugo for Best Feature for Heavenly Creatures (1994)

Chlotrudis Awards, 2003

- Won, Audience Award for Best Screenplay - Adapted for The Lord of the Rings: The Two Towers (2002) - Shared With Fran Walsh, Philippa Boyens, Stephen Sinclair

Chlotrudis Awards, 2002

- Won, Chlotrudis Award for Best Adapted Screenplay for The Lord of the Rings: The Fellowship of the Ring (2001) - Shared With Fran Walsh, Philippa Boyens

Czech Lions, 2003

- Nominated, Czech Lion for Best Foreign Language Film (Nejlepší zahraniční film) for The Lord of the Rings: The Fellowship of the Ring (2001) - New Zealand/USA.

DVD Exclusive Awards, 2005

- Won, DVDX Award for Best Audio Commentary (New for DVD) for The Lord of the Rings: The Return of the King (2003) (Special Extended Edition) - Shared With Frances Walsh, Philippa Boyens
- Nominated, DVDX Award for Best Deleted Scenes, Outtakes and Bloopers for The Lord of the Rings: The Return of the King (2003) (Special Extended Edition)
- Nominated, DVDX Award for Best New Movie Scenes (Finished, Edited Into Movie or Stand-Alone) for The Lord of the Rings: The Return of the King (2003) (Special Extended Edition)

DVD Exclusive Awards, 2003

- Won, DVD Premiere Award for Best New, Enhanced or Reconstructed Movie Scenes for The Lord of the Rings: The Fellowship of the Ring (2001) - For the Extended Edition's overall new and extended scenes included in extended film
- Won, DVD Premiere Award for Best Audio Commentary, New Release for The Lord of the Rings: The Fellowship of the Ring (2001) (Extended Edition) - Shared With Fran Walsh, Philippa Boyens
- Won, Director Award
- Won, DVDX Award for Best New Movie Scenes (Finished-Edited Into Movie or Stand-Alone) for The Lord of the Rings: The Two Towers (2002) (Special Extended Edition)
- Nominated, DVDX Award for Best Audio Commentary (New for DVD) for The Lord of the Rings: The Two Towers (2002) (Special Extended Edition) - Shared With Fran Walsh, Philippa Boyens

Control No.: 90/012,550
Patent No.: 8,174,560

Dallas-Fort Worth Film Critics Association Awards, 2004

- Won, DFWFCA Award for Best Director for The Lord of the Rings: The Return of the King (2003)

Dallas-Fort Worth Film Critics Association Awards, 2003

- Won, DFWFCA Award for Best Director for The Lord of the Rings: The Two Towers (2002)

Dallas-Fort Worth Film Critics Association Awards, 2002

- 3rd place, DFWFCA Award for Best Director for The Lord of the Rings: The Fellowship of the Ring (2001)

Directors Guild of America, USA, 2004

- Won, DGA Award for Outstanding Directorial Achievement in Motion Pictures for The Lord of the Rings: The Return of the King (2003) - Shared With Nikolas Korda (unit production manager) (plaque), Zane Weiner (unit production manager) (plaque), Carolynne Cunningham (first assistant director) (plaque), Guy Campbell (key second assistant director) (plaque), Marc Ashton (key second assistant director) (plaque)

Directors Guild of America, USA, 2003

- Nominated, DGA Award for Outstanding Directorial Achievement in Motion Pictures for The Lord of the Rings: The Two Towers (2002)

Directors Guild of America, USA, 2002

- Nominated, DGA Award for Outstanding Directorial Achievement in Motion Pictures for The Lord of the Rings: The Fellowship of the Ring (2001)

Directors Guild of Great Britain, 2004

- Won, DGGB Award for Outstanding Directorial Achievement in International Film for The Lord of the Rings: The Return of the King (2003)

Empire Awards, UK, 2013

- Nominated, Empire Award for Best Director for The Hobbit: An Unexpected Journey (2012)

Empire Awards, UK, 2006

- Nominated, Empire Award for Best Director for King Kong (2005)

Empire Awards, UK, 2004

- Nominated, Empire Award for Best Director for The Lord of the Rings: The Return of the King (2003)

Control No.: 90/012,550
Patent No.: 8,174,560

Empire Awards, UK, 2003

- Nominated, Empire Award for Best Director for The Lord of the Rings: The Two Towers (2002)

Empire Awards, UK, 2002

- Nominated, Empire Award for Best Director for The Lord of the Rings: The Fellowship of the Ring (2001)

Fantafestival, 1991

- Won, Best Direction for Meet the Feebles (1989)

Fantafestival, 1989

- Won, Audience Award for Bad Taste (1987)

Fantasporto, 1997

- Won, Audience Jury Award for Forgotten Silver (1995)

Fantafestival, 1993

- Won, International Fantasy Film Award for Best Film for Dead Alive (1992)

Fantafestival, 1991

- Nominated, International Fantasy Film Award for Best Film for Meet the Feebles (1989)

Fantafestival, 1990

- Nominated, International Fantasy Film Award for Best Film for Bad Taste (1987)

Florida Film Critics Circle Awards, 2004

- Won, FFCC Award for Best Director for The Lord of the Rings: The Return of the King (2003)

Florida Film Critics Circle Awards, 2002

- Won, FFCC Award for Best Director for The Lord of the Rings: The Fellowship of the Ring (2001)

Golden Globes, USA, 2006

- Nominated, Golden Globe for Best Director - Motion Picture for King Kong (2005)

Golden Globes, USA, 2004

- Won, Golden Globe for Best Director - Motion Picture for The Lord of the Rings: The Return of the King (2003)

Golden Globes, USA, 2003

- Nominated, Golden Globe for Best Director - Motion Picture for The Lord of the Rings: The Two Towers (2002)

Control No.: 90/012,550
Patent No.: 8,174,560

Golden Globes, USA, 2002

- Nominated, Golden Globe for Best Director - Motion Picture for The Lord of the Rings: The Fellowship of the Ring (2001)

Gérardmer Film Festival, 1995

- Won, Grand Prize for Heavenly Creatures (1994)

Hugo Awards, 2013

- Nominated, Hugo for Best Dramatic Presentation - Long Form for The Hobbit: An Unexpected Journey (2012) - Shared With Guillermo del Toro (writer), Philippa Boyens (writer), Fran Walsh (writer)

Hugo Awards, 2004

- Won, Hugo for Best Dramatic Presentation - Long Form for The Lord of the Rings: The Return of the King (2003) - Shared With Fran Walsh (screenplay), J.R.R. Tolkien (based on the book), Philippa Boyens (screenplay)
- Won, Hugo for Best Dramatic Presentation - Short Form for 2003 MTV Movie Awards (2003) - Shared With Fran Walsh (written by/director), Philippa Boyens (written by/director)
- For Gollum's acceptance speech

Hugo Awards, 2003

- Won, Hugo for Best Dramatic Presentation - Long Form for The Lord of the Rings: The Two Towers (2002) - Shared With Stephen Sinclair (screenplay), Philippa Boyens (screenplay), J.R.R. Tolkien (book), Fran Walsh (screenplay)

Hugo Awards, 2002

- Won, Hugo for Best Dramatic Presentation for The Lord of the Rings: The Fellowship of the Ring (2001) - Shared With Harvey Weinstein (executive producer), Barrie M. Osborne (producer), J.R.R. Tolkien (book), Tim Sanders (producer), Philippa Boyens (screenplay), Bob Weinstein (executive producer), Fran Walsh (screenplay)

Kansas City Film Critics Circle Awards, 2004

- Won, KCFCC Award for Best Director for The Lord of the Rings: The Return of the King (2003)
- Peter Jackson becomes the first director to win this award three consecutive years.

Kansas City Film Critics Circle Awards, 2003

- Won, KCFCC Award for Best Director for The Lord of the Rings: The Two Towers (2002)

Kansas City Film Critics Circle Awards, 2002

- Won, KCFCC Award for Best Director for The Lord of the Rings: The Fellowship of the Ring (2001)

Las Vegas Film Critics Society Awards, 2004

- Won, Sierra Award for Best Director for The Lord of the Rings: The Return of the King (2003)

Las Vegas Film Critics Society Awards, 2003

- Won, Sierra Award for Best Director for The Lord of the Rings: The Two Towers (2002)

Control No.: 90/012,550
Patent No.: 8,174,560

Las Vegas Film Critics Society Awards, 2002

- Won, Sierra Award for Best Director for The Lord of the Rings: The Fellowship of the Ring (2001)
- Nominated, Sierra Award for Best Screenplay for The Lord of the Rings: The Fellowship of the Ring (2001) - Shared With Fran Walsh, Philippa Boyens

London Critics Circle Film Awards, 2006

- Nominated, ALFS Award for Director of the Year for King Kong (2005)

London Critics Circle Film Awards, 2004

- Nominated, ALFS Award for Director of the Year for The Lord of the Rings: The Return of the King (2003)

London Critics Circle Film Awards, 2003

- Nominated, ALFS Award for Director of the Year for The Lord of the Rings: The Two Towers (2002)

London Critics Circle Film Awards, 1996

- Won, ALFS Award for Director of the Year for Heavenly Creatures (1994)

Los Angeles Film Critics Association Awards, 2004

- Won, LAFCA Award for Best Director for The Lord of the Rings: The Return of the King (2003)

National Board of Review, USA, 2001

- Won, Special Achievement Award for The Lord of the Rings: The Fellowship of the Ring (2001)

National Society of Film Critics Awards, USA, 2004

- 2nd place, NSFC Award for Best Director for The Lord of the Rings: The Return of the King (2003)

New Zealand Film and TV Awards (I), 1996

- Won, TV Award for Best Director - Drama/Comedy for Forgotten Silver (1995) - Shared With Costa Botes

New Zealand Film and TV Awards (I), 1995

- Won, Film Award for Best Director for Heavenly Creatures (1994)

New Zealand Film and TV Awards (I), 1993

- Won, Film Award for Best Director for Dead Alive (1992)
- Won, Film Award for Best Screenplay for Dead Alive (1992) - Shared With Stephen Sinclair, Fran Walsh

Online Film Critics Society Awards, 2006

- Nominated, OFCS Award for Best Director for King Kong (2005)

Control No.: 90/012,550
Patent No.: 8,174,560

Online Film Critics Society Awards, 2004

- Won, OFCS Award for Best Director for The Lord of the Rings: The Return of the King (2003)
- Won, OFCS Award for Best Screenplay, Adapted for The Lord of the Rings: The Return of the King (2003) - Shared With Philippa Boyens, Fran Walsh

Online Film Critics Society Awards, 2003

- Won, OFCS Award for Best Director for The Lord of the Rings: The Two Towers (2002)
- Nominated, OFCS Award for Best Screenplay, Adapted for The Lord of the Rings: The Two Towers (2002) - Shared With Fran Walsh, Philippa Boyens, Stephen Sinclair

Online Film Critics Society Awards, 2002

- Nominated, OFCS Award for Best Director for The Lord of the Rings: The Fellowship of the Ring (2001)
- Nominated, OFCS Award for Best Screenplay, Adapted for The Lord of the Rings: The Fellowship of the Ring (2001) - Shared With Fran Walsh, Philippa Boyens

PGA Awards, 2012

- Won, PGA Award for Outstanding Producer of Animated Theatrical Motion Pictures for The Adventures of Tintin (2011) - Shared With Steven Spielberg, Kathleen Kennedy

PGA Awards, 2010

- Nominated, PGA Award for Outstanding Producer of Theatrical Motion Pictures for District 9 (2009) - Shared WithCarolynne Cunningham

PGA Awards, 2004

- Won, PGA Award for Outstanding Producer of Theatrical Motion Pictures for The Lord of the Rings: The Return of the King (2003) - Shared With Barrie M. Osborne, Fran Walsh

PGA Awards, 2003

- Nominated, PGA Award for Outstanding Producer of Theatrical Motion Pictures for The Lord of the Rings: The Two Towers (2002) - Shared With Barrie M. Osborne, Fran Walsh

Phoenix Film Critics Society Awards, 2004

- Won, PFCS Award for Best Director for The Lord of the Rings: The Return of the King (2003)
- Won, PFCS Award for Best Screenplay, Adapted for The Lord of the Rings: The Return of the King (2003) - Shared With Fran Walsh, Philippa Boyens

Control No.: 90/012,550
Patent No.: 8,174,560

Phoenix Film Critics Society Awards, 2003

- Won, PFCS Award for Best Screenplay - Adapted for The Lord of the Rings: The Two Towers (2002) - Shared With Frances Walsh, Philippa Boyens, Stephen Sinclair
- Nominated, PFCS Award for Best Director for The Lord of the Rings: The Two Towers (2002)

Phoenix Film Critics Society Awards, 2002

- Won, PFCS Award for Best Director for The Lord of the Rings: The Fellowship of the Ring (2001)
- Won, PFCS Award for Best Screenplay - Adaptation for The Lord of the Rings: The Fellowship of the Ring (2001) - Shared With Fran Walsh, Philippa Boyens

Robert Festival, 2004

- Nominated, Robert for Best American Film (Årets amerikanske film) for The Lord of the Rings: The Return of the King (2003)

Robert Festival, 2003

- Nominated, Robert for Best American Film (Årets amerikanske film) for The Lord of the Rings: The Two Towers (2002)

Robert Festival, 2002

- Won, Robert for Best American Film (Årets amerikanske film) for The Lord of the Rings: The Fellowship of the Ring (2001)

SFX Awards, UK, 2004

- Won, SFX Award for Best Film Director for The Lord of the Rings: The Return of the King (2003)

SFX Awards, UK, 2003

- Won, SFX Award for Best SF or Fantasy Film Director for The Lord of the Rings: The Two Towers (2002)

San Diego Film Critics Society Awards, 2003

- Won, SDFCS Award for Best Director for The Lord of the Rings: The Return of the King (2003)

San Francisco Film Critics Circle, 2003

- Won, SFFCC Award for Best Director for The Lord of the Rings: The Return of the King (2003)

Santa Barbara International Film Festival, 2004

- Won, Modern Master Award

Satellite Awards, 2003

- Nominated, Golden Satellite Award for Best Director for The Lord of the Rings: The Two Towers (2002)
- Nominated, Golden Satellite Award for Best Screenplay, Adapted for The Lord of the Rings: The Two Towers (2002) - Shared With Fran Walsh, Philippa Boyens, Stephen Sinclair

Control No.: 90/012,550
Patent No.: 8,174,560

Satellite Awards, 2002

- Nominated, Golden Satellite Award for Best Screenplay, Adapted for The Lord of the Rings: The Fellowship of the Ring (2001) - Shared With Fran Walsh, Philippa Boyens

Science Fiction and Fantasy Writers of America, 2005

- Won, Nebula Award for Best Script for The Lord of the Rings: The Return of the King (2003) - Shared With Fran Walsh, Philippa Boyens

Science Fiction and Fantasy Writers of America, 2004

- Won, Nebula Award for Best Script for The Lord of the Rings: The Two Towers (2002) - Shared With Fran Walsh, Philippa Boyens, Stephen Sinclair

Science Fiction and Fantasy Writers of America, 2003

- Won, Nebula Award for Best Script for The Lord of the Rings: The Fellowship of the Ring (2001) - Shared With Fran Walsh, Philippa Boyens

Seattle Film Critics Awards, 2002

- 2nd place, Seattle Film Critics Award for Best Director for The Lord of the Rings: The Two Towers (2002)
- 2nd place, Seattle Film Critics Award for Best Screenplay, Adapted for The Lord of the Rings: The Two Towers (2002) - Shared With Philippa Boyens, Stephen Sinclair, Fran Walsh

Sitges - Catalanian International Film Festival, 1996

- Nominated, Best Film for The Frighteners (1996)

Sitges - Catalanian International Film Festival, 1992

- Nominated, Best Film for Dead Alive (1992)

Southeastern Film Critics Association Awards, 2003

- Won, SEFCA Award for Best Director for The Lord of the Rings: The Return of the King (2003)
- 2nd place, SEFCA Award for Best Screenplay, Adapted for The Lord of the Rings: The Return of the King (2003) - Shared With Fran Walsh, Philippa Boyens

Southeastern Film Critics Association Awards, 2001

- Won, SEFCA Award for Best Director for The Lord of the Rings: The Fellowship of the Ring (2001)
- Won, SEFCA Award for Best Screenplay, Adapted for The Lord of the Rings: The Fellowship of the Ring (2001) - Shared With Fran Walsh, Philippa Boyens

Control No.: 90/012,550
Patent No.: 8,174,560

Toronto Film Critics Association Awards, 2003

- Won, TFCA Award for Best Director for The Lord of the Rings: The Return of the King (2003)
- Won, Special Citation For his work for his work on the "Lord of the Rings" trilogy as a whole

Toronto Film Critics Association Awards, 2001

- Nominated, TFCA Award for Best Director for The Lord of the Rings: The Fellowship of the Ring (2001)

Toronto International Film Festival, 1994

- Won, Metro Media Award for Heavenly Creatures (1994)

USC Scriptor Award, 2004

- Nominated, USC Scriptor Award for for The Lord of the Rings: The Return of the King (2003)
- Shared With Fran Walsh (screenwriter), Philippa Boyens (screenwriter), J.R.R. Tolkien (author)

USC Scriptor Award, 2003

- Nominated, USC Scriptor Award for The Lord of the Rings: The Two Towers (2002) - Shared With Fran Walsh (screenwriter), Philippa Boyens (screenwriter), Stephen Sinclair (screenwriter), J.R.R. Tolkien (author)

USC Scriptor Award, 2002

- Nominated, USC Scriptor Award for The Lord of the Rings: The Fellowship of the Ring (2001)
- Shared With Fran Walsh (screenwriter), Philippa Boyens (screenwriter), J.R.R. Tolkien (author)

Vancouver Film Critics Circle, 2004

- Won, VFCC Award for Best Director for The Lord of the Rings: The Return of the King (2003)

Venice Film Festival, 1994

- Won, Silver Lion for for Heavenly Creatures (1994)
- Nominated, Golden Lion for Heavenly Creatures (1994)

Washington DC Area Film Critics Association Awards, 2003

- Won, WAFCA Award for Best Director for The Lord of the Rings: The Return of the King (2003)
- Nominated, WAFCA Award for Best Screenplay, Adapted for The Lord of the Rings: The Return of the King (2003) - Shared With Frances Walsh, Philippa Boyens

Writers Guild of America, USA, 2004

- Nominated, WGA Award (Screen) for Best Adapted Screenplay for The Lord of the Rings: The Return of the King (2003) - Shared With Fran Walsh, Philippa Boyens

Control No.: 90/012,550
Patent No.: 8,174,560

Writers Guild of America, USA, 2002

- Nominated, WGA Award (Screen) for Best Screenplay Based on Material Previously Produced or Published for The Lord of the Rings: The Fellowship of the Ring (2001) - Shared With Fran Walsh, Philippa Boyens

Writers Guild of America, USA, 1995

- Nominated, WGA Award (Screen) for Best Screenplay Written Directly for the Screen for Heavenly Creatures (1994) - Shared With Fran Walsh

Young Artist Awards, 2004

- Won, Jackie Coogan Award for the Lord of the Rings

15426724
051613

COPY

REDCOM.007X1

PATENT

IN THE UNITED STATES PATENT AND TRADEMARK OFFICE

Applicant : James Jannard, et al.
Reexam Control No. : 90/012,550
Reexam Filed : September 13, 2012
Patent No. : 8,174,560
For : VIDEO CAMERA
Examiner : Henry N. Tran
Art Unit : 3992
Conf No. : 1159

CERTIFICATE OF EFS WEB
TRANSMISSION

I hereby certify that this correspondence, and any other attachment noted on the automated Acknowledgement Receipt, is being transmitted from within the Pacific Time zone to the Commissioner for Patents via the EFS Web server on:

July 1, 2013

(Date)

/Michael Guiliana/

Michael A. Guiliana, Reg. no. 42,611

DECLARATION OF DON M. BURGESS UNDER 37 C.F.R. §1.132

Commissioner for Patents
P.O. Box 1450
Alexandria, VA 22313-1450

Dear Sir:

I, Don M. Burgess, declare that:

1. I am a professional film maker, and have participated in productions in roles such as Cinematographer, with the Camera and Electrical Department, and as an Actor. A table showing my filmography is attached as Exhibit A. I have also been honored with several awards, a list of which is attached as Exhibit B.

2. I have purchased and operated video cameras made by Red.com, Inc. ("RED"), specifically those cameras sold under the names "RED ONE" and "RED EPIC". I understand that RED is the owner of U.S. Patent No. 8,174,560 ("the 560 patent"), which is the subject of the present reexamination proceeding. The Patent Owner has asked me to provide an explanation of my experience with and opinions of the RED ONE and RED EPIC cameras. The patent owner has not compensated me for my time spent preparing the present Declaration.

Control No.: 90/012,550
Patent No.: 8,174,560

3. Prior to my work on Book of Eli, which began filming on January 29, 2009, I had used film cameras for all of the projects listed in my filmography. Thus, my experience with film-based production spans over 29 years. Included in those film-based productions is Forrest Gump (1994), Spiderman (2002) and Terminator 3: Rise of the Machines (2003).

4. Although some digital cameras had been marketed, in the mid-2000s, as “cinema ready”, I was reluctant to shoot any projects with a digital camera until I was asked to serve as Director of Photography on "Book of Eli". The Directors (Albert and Allen Hughes) asked me to use RED digital cameras. I did a test and found the RED ONE to provide results equal to film. This is the first time I realized that compressed digital image data could be sufficiently visually lossless to be "good enough" to match the quality of film and with all the advantages that digital had to offer.

5. I shot The Book of Eli using the RED ONE camera in the optional 4K REDCODE RAW format in which the RED ONE camera stored RAW image data in a compressed format, using removable Compact Flash cards. My experience as Director of Photography on The Book of Eli convinced me that the RED ONE camera provided results that were the equal of film, in a package that is just portable as a film camera, but cheaper and faster than film. Specifically, the RED ONE camera was able to achieve these results by compressing and recording raw digital image data with resolutions of at least 2K (including 4K) into storage devices of the camera (e.g., carried on or within a portably housing of the camera). The RED ONE compresses the raw digital image data such that the data remains substantially visually lossless upon decompression. The lower data rate resulting from compressing the RAW image data provides the RED ONE with the ability to record reasonable amounts of footage, at high resolution, using standard digital media devices such as Compact Flash cards, which provide about as much recording time as a small canister of 35mm film which held approximately 400 ft. of film. The RED ONE and RED EPIC can also record to larger Solid State Drives (SSD) and even larger physical hard drives which can provide hours of recording; far more than any single reel of film.

Control No.: 90/012,550
Patent No.: 8,174,560

6. After shooting "The Book of Eli", I shot every subsequent feature on RED cameras, including "Source Code", "The Muppets", "Flight", "42", and "The Muppets 2".

7. My decision to continue to purchase and use RED cameras is based primarily on the ability of the RED cameras to record compressed RAW digital image data having a resolution of at least 2k and higher onto a memory device of the camera (e.g., on or in a portable housing of the camera) at a rate of at least 23 frames per second, such that the data remains substantially visually lossless upon decompression. My decisions are not based on any competitive price comparisons or advertising.

8. All statements made herein of my own knowledge are true. All statements made on information and belief are believed to be true. These statements were made with the knowledge that willful false statements and the like so made are punishable by fine, imprisonment, or both, under 18 U.S.C. § 1001, and that such willful false statements may jeopardize the validity of the application or any patent issuing therefrom.

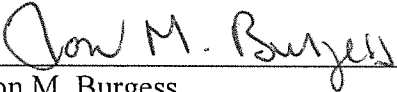

Don M. Burgess

6/24/13

Date

15329107
050113

Control No.: 90/012,550
Patent No.: 8,174,560

EXHIBIT A

Filmography

As a Cinematographer		
Title	Job	Year
The Muppets... Again!	Filming	2014
42	Director of Photography	2013
Flight	Director of Photography	2012/I
The Muppets	Director of Photography	2011
Priest		2011
Source Code	Director of Photography	2011
The Book of Eli	Director of Photography	2010
Aliens in the Attic	Director of Photography	2009
Fool's Gold		2008
Enchanted	Director of Photography	2007
The Trap	Director of Photography	2007
My Super Ex-Girlfriend		2006
Eight Below	Director of Photography	2006
Christmas with the Kranks	Director of Photography	2004
The Polar Express	Director of Photography	2004
13 Going on 30	Director of Photography	2004
Radio	Director of Photography	2003
Terminator 3: Rise of the Machines	Director of Photography	2003
Spider-Man	Director of Photography	2002
Cast Away	Director of Photography	2000
What Lies Beneath	Director of Photography	2000
Contact		1997
The Evening Star		1996
Forget Paris		1995
Richie Rich	Director of Photography	1994
Forrest Gump	Director of Photography	1994
Josh and S.A.M.		1993
Space Rangers (TV Series) - Fort Hope	Director of Photography	1993
Night Trap (Video Game)	Director of Photography	1992
Mo' Money	Director of Photography	1992
Two-Fisted Tales (TV movie) (segment "Yellow")		1992
Tales from the Crypt (TV series) - Yellow		1991
The Court-Martial of Jackie Robinson (TV movie)		1990
Braking Point (TV movie)		1989

Control No.: 90/012,550

Patent No.: 8,174,560

Blind Fury		1989
Under the Boardwalk		1989
World Gone Wild		1988
Too Young the Hero (TV movie)		1988
The Night Stalker		1987
Summer Camp Nightmare	Director of Photography	1987
Death Before Dishonor		1987
Playboy: Bedtime Stories (video documentary)		1987
Fury to Freedom	Director of Photography	1985
Ruckus (as Don Michael Burgess)		1980
Superstunt II (TV movie)		1980
Camera and Electrical Department		
Title of Movie	Job	Year
The Bourne Identity	Additional Photographer	2002
Deep Impact	Additional camera operator, additional photographer	1998
Executive Decision	Additional Photographer	1996
Traces of Red	Additional Photographer	1992
Death Becomes Her	Director of Photography; second unit	1992
Batman Returns	Director of Photography; second unit	1992
Noises Off...	Director of Photography; second unit	1992
Keeper of the City (TV movie)	Additional camera operator: Chicago	1991
Backdraft	Director of Photography; second unit	1991
Nothing But Trouble	Director of Photography; second unit	1991
The Rookie	Director of Photography; second unit	1990
Back to the Future Part III	Director of Photography; second unit	1990
Back to the Future Part II	Director of Photography; second unit	1989
Lucky Stiff	Director of Photography; second unit	1988
Moving	Director of Photography; second unit	1988
Cherry 2000	Camera operator: second unit, Director of Photography; second unit	1987
Hot Pursuit	Camera operator	1987
Quiet Cool	Director of Photography; second unit	1986
Runaway Train	Director of Photography; second unit	1985
Sheena: Queen of the Jungle	Action Photographer	1984
Hog Dog... The Movie	Camera operator: second unit	1984
To the Ends of the Earth (Documentary)	Photographer	1983
Happy Birthday to Me	Camera operator: second unit	1981

Control No.: 90/012,550
Patent No.: 8,174,560

EXHIBIT B

Awards

Academy Awards, USA 1995

- Nominated, Oscar for Best Cinematography for *Forrest Gump* (1994)

American Society of Cinematographers, USA 1995

- Nominated, ASC Award for Outstanding Achievement in Cinematography in Theatrical Releases for *Forrest Gump* (1994)

ASC Award, 1991

- Nominated, ASC Award for Outstanding Achievement in Cinematography in Movies of the Week/Pilots for *The Court-Martial of Jackie Robinson* (1990)

BAFTA Awards, 1995

- Nominated, BAFTA Film Award for Best Cinematography for *Forrest Gump* (1994)

Chicago Film Critics Association Awards, 2001

- Nominated, CFCA Award for Best Cinematography for *Cast Away* (2000)

Las Vegas Film Critics Society Awards, 2000

- Nominated, Sierra Award for Best Cinematography for *Cast Away* (2000)

Phoenix Film Critics Society Awards, 2001

- Nominated, PFCS Award for Best Cinematography for *Cast Away* (2000)

Satellite Awards, 1998

- Nominated, Golden Satellite Award for Outstanding Cinematography for *Contact* (1997)

15404313
051413

COPY

REDCOM.007X1

PATENT

IN THE UNITED STATES PATENT AND TRADEMARK OFFICE

Applicant : James Jannard, et al.
Reexam Control No. : 90/012,550
Reexam Filed : September 13, 2012
Patent No. : 8,174,560
For : VIDEO CAMERA
Examiner : Henry N. Tran
Art Unit : 3992
Conf No. : 1159

CERTIFICATE OF EFS WEB
TRANSMISSION

I hereby certify that this correspondence, and any other attachment noted on the automated Acknowledgement Receipt, is being transmitted from within the Pacific Time zone to the Commissioner for Patents via the EFS Web server on:

July 1, 2013

(Date)

/Michael Guiliiana/

Michael A. Guiliiana, Reg. no. 42,611

DECLARATION OF STEVEN SODERBERGH UNDER 37 C.F.R. §1.132

Commissioner for Patents
P.O. Box 1450
Alexandria, VA 22313-1450

Dear Sir:

I, Steven Soderbergh, declare that:

1. I am a professional film maker, and have participated in motion picture productions in the roles of Producer, Director, and Cinematographer. My filmography is attached as Exhibit A. Exhibit B includes a list of awards and nominations I have received.

2. In my experience with various productions, I have personally used and directed the use of cameras made by Red.com, Inc., (“RED”).

3. I first used a “RED ONE” in 2007 during production of Che: Part One (2008) and I later used a “RED EPIC” on Magic Mike (2012) as well as other productions. I understand that RED is the owner of United States Patent No. 8,174,560, which is the subject of the above-identified reexamination proceeding. RED has asked me to explain my experience with the RED ONE and RED EPIC cameras. RED has not compensated me for my time spent preparing this Declaration.

Control No.: 90/012,550
Patent No.: 8,174,560

4. Prior to 2007, all of my productions were film-based. Additionally, prior to 2007, I was aware that some companies were marketing “1080p” camera systems for the cinema market. The “1080p” recording format corresponds to a progressive scan format with a resolution of 1920 x 1080 pixels. My recollection is that certain systems require an RGB codec and an external box for recording, which was bulky. Additionally, recording directly into the 1080p format did not provide sufficient quality or post-production flexibility for cinema productions.

5. One way to eliminate the problems caused by recording directly into a rendered format such as the 1080p format, is to record raw digital image data. However, recording a stream of raw digital image data having a resolution of at least 2K (including 4K) would have required even larger and more difficult to operate recording systems than the prior 1080p format systems. Thus, I was not willing to risk the success of any of my productions using such digital systems at that time.

6. In early 2007, however, I first viewed Peter Jackson’s short film *Crossing the Line* (which was shot on prototype RED cameras), and a whole new world of possibilities opened up to me. I learned that RED overcame the problems of the prior digital systems noted above by creating a camera system that could compress and record raw digital image data having a resolution of at least 2K (including 4k) into a storage device of the camera (e.g., carried on or within a portable housing of the camera) at a frame rate of at least about twenty-three frames per second. RED’s camera systems compress the raw digital image data such that the data remains substantially visually lossless upon decompression, and so that the data rate was sufficiently low that the digital storage devices could store a reasonable amount of footage before needing replacement.

7. After I became familiar with the RED ONE camera, I decided to use the RED ONE to shoot my next feature films *Che: Part One* and *Che: Part Two*. The results were so satisfying to me that I continued to shoot all of my subsequent projects on Red Digital cameras, either Red One or Red Epic. Those projects include:

8. The Informant!

Control No.: 90/012,550
Patent No.: 8,174,560

9. The Girlfriend Experience
10. Contagion
11. Haywire
12. Magic Mike
13. Side Effects
14. Behind the Candelabra

15. I believe the ability to record 4k resolution image data to a memory device such as a Compact Flash card or small SSD card onboard the camera with cinema grade quality, for example, by way of visually lossless compression, is so significant that it will require its own chapter in the story of motion picture production, and I am proud to have been a witness to--and a participant in--its development and release.

16. For the foreseeable future, I will continue to purchase and use RED cameras for my productions. My continued reliance on RED cameras is based primarily on the ability of the RED cameras to record compressed RAW digital image data having 4k resolution onto a memory device of the camera (e.g., on or in a portable housing of the camera) at a rate of at least 23 frames per second, such that the data remains substantially visually lossless upon decompression. My decisions are not based on any competitive price comparisons or advertising.

17. All statements made herein of my own knowledge are true. All statements made on information and belief are believed to be true. These statements were made with the knowledge that willful false statements and the like so made are punishable by fine, imprisonment, or both, under 18 U.S.C. § 1001, and that such willful false statements may jeopardize the validity of the application or any patent issuing therefrom.

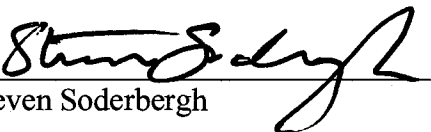
Steven Soderbergh

6-24-13
Date

Control No.: 90/012,550
Patent No.: 8,174,560

EXHIBIT A

Filmography

Title of Movie	Job	Year
Yes: 90125 Live (Documentary)	Director	1985
Access All Areas (Documentary short)	Director	1985
Winston (Short)	Director	1987
Sex, Lies, and Videotape	Director	1989
Kafka	Director	1991
King of the Hill	Director	1993
The Underneath	Director	1995
Gray's Anatomy (Dramatized monologue)	Director	1996
Schizopolis	Director	1996
Out of Sight	Director	1998
The Limey	Director	1999
Erin Brockovich	Director	2000
Traffic	Director	2000
Ocean's Eleven	Director	2001
Full Frontol	Director	2002
Solaris	Director	2002
K Street (TV series)	Director	2003
Equilibrium (Short segment of Eros)	Director	2004
Ocean's Twelve	Director	2004
Bubble	Director	2005
Building No. 7 (Short)	Director	2006
The Good German	Director	2006
Ocean's Thirteen	Director	2007
Che	Director	2008
The Girlfriend Experience	Director	2009
The Informant?	Director	2009
And Everything is Going Fine (Documentary)	Director	2010
The Last Time I Saw Michael Gregg (unreleased)	Director	2011
Contagion	Director	2011
Haywire	Director	2012
Magic Mike	Director	2012
An Amazing Time: A Conversation About 'End of the Road' (TV documentary)	Director	2012
Side Effects	Director	2013
Behind the Candelabra	Director	2013
Sex, Lies, and Videotape	Screenwriter	1989
King of the Hill	Screenwriter	1993
The Underneath as Sam Lowry	Screenwriter	1995

Control No.: 90/012,550

Patent No.: 8,174,560

Schizopolis	Screenwriter	1996
Nightwatch	Screenwriter	1997
Solaris	Screenwriter	2002
Criminal as Sam Lowry	Screenwriter	2004
Eros – the segment “Equilibrium”	Screenwriter	2004
Schizopolis	Cinematographer	1996
Traffic – as Peter Andrews	Cinematographer	2000
Ocean’s Eleven – as Peter Andrews	Cinematographer	2001
Full Frontal – as Peter Andrews	Cinematographer	2002
Solaris – as Peter Andrews	Cinematographer	2002
Ocean’s Twelve – as Peter Andrews	Cinematographer	2004
Eros – the segment “Equilibrium”	Cinematographer	2004
Bubble – as Peter Andrews	Cinematographer	2006
The Good German – as Peter Andrews	Cinematographer	2006
Ocean’s Thirteen– as Peter Andrews	Cinematographer	2007
Che – as Peter Andrews	Cinematographer	2008
The Girlfriend Experience – as Peter Andrews	Cinematographer	2009
The Informant! – as Peter Andrews	Cinematographer	2009
Contagion – as Peter Andrews	Cinematographer	2011
Haywire – as Peter Andrews	Cinematographer	2012
Magic Mike – as Peter Andrews	Cinematographer	2012
Side Effects – as Peter Andrews	Cinematographer	2013
Sex, Lies, and Videotape	Editor	1989
Kafka	Editor	1991
King of the Hill	Editor	1993
Solaris – as Mary Ann Bernard	Editor	2002
Eros – The segment “Equilibrium”	Editor	2004
Bubble – as Mary Ann Bernard	Editor	2006
The Good German – as Mary Ann Bernard	Editor	2006
The Girlfriend Experience – as Mary Ann Bernard	Editor	2009
Haywire – as Mary Ann Bernard	Editor	2012
Magic Mike – as Mary Ann Bernard	Editor	2012
Side Effects – as Mary Ann Bernard	Editor	2013
The Hunger Games	Second Unit Director	2012
Suture	Producer	1994
The Daytrippers	Producer	1996
Pleasantville	Producer	1998
Far from Heaven	Producer	2002
Confessions of a Dangerous Mind	Producer	2002
Insomnia	Producer	2002
Welcome to Collinwood	Producer	2002
Naqoyqatsi	Producer	2002
Keane	Producer	2004

Control No.: 90/012,550
Patent No.: 8,174,560

Criminal	Producer	2004
Syriana	Producer	2005
Good Night, and Good Luck	Producer	2005
The Jacket	Producer	2005
Rumor Has It...	Producer	2005
Pu-239	Producer	2006
A Scanner Darkly	Producer	2006
I'm No There	Producer	2007
Michael Clayton	Producer	2007
Wind Chill	Producer	2007
Tishomingo Blues	Producer	2008
Solitary Man	Producer	2009
We Need to Talk About Kevin	Producer	2011

Control No.: 90/012,550
Patent No.: 8,174,560

EXHIBIT B

Awards

Academy Awards, USA, 2001

- Won, Oscar for Best Director for Traffic (2000)
- Nominated, Oscar for Best Director for Erin Brockovich (2000)

Academy Awards, USA, 1990

- Nominated, Oscar for Best Writing, Screenplay Written Directly for the Screen for Sex, Lies, and Videotape (1989)

Amanda Awards, Norway, 2001

- Nominated, Amanda for Best Foreign Feature Film (Årets utenlandske spillefilm) for Traffic (2000)

Amanda Awards, Norway, 2000

- Nominated, Amanda for Best Foreign Feature Film (Årets utenlandske kinofilm) for Erin Brockovich (2000)

BAFTA Awards, 2001

- Nominated, David Lean Award for Direction for Erin Brockovich (2000)
- Nominated, David Lean Award for Direction for Traffic (2000)

BAFTA Awards, 1990

- Nominated, BAFTA Film Award for Best Screenplay - Original for Sex, Lies, and Videotape (1989)

Berlin International Film Festival, 2013

- Nominated, Golden Berlin Bear for Side Effects (2013)

Berlin International Film Festival, 2007

- Nominated, Golden Berlin Bear for The Good German (2006)

Berlin International Film Festival, 2003

- Nominated, Golden Berlin Bear for Solaris (2002)

Berlin International Film Festival, 2001

- Nominated, Golden Berlin Bear for Traffic (2000)

Bodil Awards, 2002

- Nominated, Bodil for Best American Film (Bedste amerikanske film) for Traffic (2000)

Control No.: 90/012,550

Patent No.: 8,174,560

Boston Society of Film Critics Awards, 2000

- 3rd place, BSFC Award for Best Director for Erin Brockovich (2000) and Traffic (2000) - Tied with Michael Winterbottom for Wonderland and The Claim

Boston Society of Film Critics Awards, 1998

- 2nd place, BSFC Award for Best Director for Out of Sight (1998)

British Society of Cinematographers, 2001

- Nominated, Best Cinematography Award for Traffic (2000)

Broadcast Film Critics Association Awards, 2001

- Won, Critics Choice Award for Best Director for Traffic (2000) and Erin Brockovich (2000)

CableACE Awards, 1995

- Nominated, CableACE for Directing a Dramatic Special or Series for Fallen Angels (1993) (Showtime) for episode "Professional Man"

CableACE Awards, 1994

- Nominated, CableACE Directing a Dramatic Series for Fallen Angels (1993) (Showtime) for episode "The Quiet Room"

Cannes Film Festival, 2013

- Nominated, Palme d'Or for Behind the Candelabra (2013)

Cannes Film Festival, 2008

- Nominated, Palme d'Or for Che: Part One (2008) and Che: Part Two (2008)

Cannes Film Festival, 1993

- Nominated, Palme d'Or for King of the Hill (1993)

Cannes Film Festival, 1989

- Won, Palme d'Or for Sex, Lies, and Videotape (1989)
- Won, FIPRESCI Prize for Sex, Lies, and Videotape (1989) - Tied with Yaaba

Chicago Film Critics Association Awards, 2001

- Won, CFCA Award for Best Director for Traffic (2000)
- Nominated, CFCA Award for Best Cinematography for Traffic (2000)

Chicago Film Critics Association Awards, 1990

- Nominated, CFCA Award for Best Director for Sex, Lies, and Videotape (1989)

Chlotrudis Awards, 2001

- Nominated, Chlotrudis Award for Best Director for Traffic (2000)

Control No.: 90/012,550

Patent No.: 8,174,560

César Awards, France, 2003

- Nominated, César for Best Foreign Film (Meilleur film étranger) for Ocean's Eleven (2001)

César Awards, France, 2002

- Nominated, César for Best Foreign Film (Meilleur film étranger) for Traffic (2000)

César Awards, France, 1990

- Nominated, César for Best Foreign Film (Meilleur film étranger) for Sex, Lies, and Videotape (1989)

Dallas-Fort Worth Film Critics Association Awards, 2001

- Won, DFWFCA Award for Best Director for Traffic (2000)

Directors Guild of America, USA, 2001

- Nominated, DGA Award for Outstanding Directorial Achievement in Motion Pictures for Erin Brockovich (2000)
- Nominated, DGA Award for Outstanding Directorial Achievement in Motion Pictures for Traffic (2000)

Empire Awards, UK, 2003

- Nominated, Empire Award for Best Director for Ocean's Eleven (2001)

Empire Awards, UK, 2002

- Nominated, Empire Award for Best Director for Traffic (2000)

European Film Awards, 2000

- Nominated, Screen International Award for Erin Brockovich (2000)

Florida Film Critics Circle Awards, 2001

- Won, FFCC Award for Best Director for Erin Brockovich (2000) and Traffic (2000)

Golden Globes, USA, 2001

- Nominated, Golden Globe for Best Director - Motion Picture for Erin Brockovich (2000)
- Nominated, Golden Globe for Best Director - Motion Picture for Traffic (2000)

Golden Globes, USA, 1990

- Nominated, Golden Globe for Best Screenplay - Motion Picture for Sex, Lies, and Videotape (1989)

Grammy Awards, 1987

- Nominated, Grammy for Best Music Video, Long Form for Yes: 9012 Live (1985) - Shared With: Jon Anderson (artist), Tony Kaye (artist), Trevor Rabin (artist), Chris Squire (artist), Alan White (artist), unknown (video producer)

Control No.: 90/012,550

Patent No.: 8,174,560

Independent Spirit Awards, 2007

- Nominated, Independent Spirit Award for Best Director for Bubble (2005)

Independent Spirit Awards, 2000

- Nominated, Independent Spirit Award for Best Director for The Limey (1999)

Independent Spirit Awards, 1990

- Won, Independent Spirit Award for Best Director for Sex, Lies, and Videotape (1989)

Italian National Syndicate of Film Journalists, 2001

- Nominated, Silver Ribbon for Best Foreign Director (Regista del Miglior Film Straniero) for Traffic (2000)

Kansas City Film Critics Circle Awards, 2001

- Won, KCFCC Award for Best Director for Traffic (2000)

Kinema Junpo Awards, 2002

- Won, Kinema Junpo Award for Best Foreign Language Film for Traffic (2000)
- Won, Kinema Junpo Award for Best Foreign Language Film Director for Traffic (2000)

Las Vegas Film Critics Society Awards, 2000

- Won, Sierra Award for Best Director for Erin Brockovich (2000) and Traffic (2000)

London Critics Circle Film Awards, 2001

- Nominated, ALFS Award for Director of the Year for Erin Brockovich (2000)

Los Angeles Film Critics Association Awards, 2000

- Won, LAFCA Award for Best Director for Erin Brockovich (2000) and Traffic (2000)
- 2nd place, LAFCA Award for Best Cinematography for Traffic (2000)

National Board of Review, USA, 2000

- Won, NBR Award for Best Director for Erin Brockovich (2000) and Traffic (2000)

National Society of Film Critics Awards, USA, 2001

- Won, NSFC Award for Best Director for Traffic (2000) and Erin Brockovich (2000)

National Society of Film Critics Awards, USA, 1999

- Won, NSFC Award for Best Director for Out of Sight (1998)

National Society of Film Critics Awards, USA, 1990

- 2nd place, NSFC Award for Best Screenplay for Sex, Lies, and Videotape (1989)

New York Film Critics Circle Awards, 2000

- Won, NYFCC Award for Best Director for Erin Brockovich (2000) and Traffic (2000)

Control No.: 90/012,550

Patent No.: 8,174,560

New York Film Critics Circle Awards, 1989

- 2nd place, NYFCC Award for Best Screenplay for Sex, Lies, and Videotape (1989)

Online Film Critics Society Awards, 2009

- Nominated, OFCS Award for Best Cinematography for Che: Part One (2008) and Che: Part Two (2008)

Online Film Critics Society Awards, 2001

- Nominated, OFCS Award for Best Director for Traffic (2000)
- Nominated, OFCS Award for Best Cinematography for Traffic (2000)

Phoenix Film Critics Society Awards, 2001

- Won, PFCS Award for Best Director for Traffic (2000)
- Nominated, PFCS Award for Best Cinematography for Traffic (2000)

Primetime Emmy Awards, 2011

- Nominated, Primetime Emmy for Outstanding Nonfiction Special for His Way (2011) - Shared With: Audrey Rosenberg (executive producer), Graydon Carter (produced by), Alan Polsky (produced by), Gabe Polsky (produced by)

Primetime Emmy Awards, 2009

- Nominated, Primetime Emmy for Outstanding Nonfiction Special for Roman Polanski: Wanted and Desired (2008) - Shared With: Randy Wooten (executive producer), Jeffrey Levy-Hinte (produced by), Lila Yacoub (produced by), Marina Zenovich (produced by) (HBO)

Satellite Awards, 2001

- Won, Golden Satellite Award for Best Director for Traffic (2000)
- Nominated, Golden Satellite Award for Best Director for Erin Brockovich (2000)
- Nominated, Golden Satellite Award for Best Cinematography for Traffic (2000)

Satellite Awards, 1999

- Nominated, Golden Satellite Award for Best Motion Picture - Comedy or Musical for Pleasantville (1998) - Shared With: Bob Degus, Jon Kilik, Gary Ross

Southeastern Film Critics Association Awards, 2001

- Won, SEFCA Award for Best Director for Traffic (2000)

Sundance Film Festival, 1989

- Won, Audience Award for Dramatic for Sex, Lies, and Videotape (1989)
- Nominated, Grand Jury Prize for Dramatic for Sex, Lies, and Videotape (1989)

Toronto Film Critics Association Awards, 2000

- Won, TFCA Award for Best Director for Traffic (2000)

Control No.: 90/012,550
Patent No.: 8,174,560

Vancouver Film Critics Circle, 2001

- Won, VFCC Award for Best Director for Traffic (2000)

Writers Guild of America, USA, 1990

- Nominated, WGA Award (Screen) for Best Screenplay Written Directly for the Screen for Sex, Lies, and Videotape (1989)

15404313
051413
15411091
051413

INFORMATION DISCLOSURE STATEMENT

Inventor	: James H. Jannard
App. No.	: 14/485612
Filed	: September 12, 2014
For	: VIDEO CAMERA
Examiner	: Diep, Trung T.
Art Unit	: 2664
Conf. No.	: 1068

Mail Stop Amendment
 Commissioner for Patents
 P.O. Box 1450
 Alexandria, VA 22313-1450

References and Listing

Pursuant to 37 CFR 1.56, an Information Disclosure Statement listing references is provided herewith. Copies of any listed foreign and non-patent literature references are being submitted. Any foreign references may also include English abstract(s) and/or machine translation(s), but no representation is made as to their accuracy.

If the Examiner would like additional information regarding these references or if anything is unclear, the Examiner is invited to contact the undersigned for assistance.

Pursuant to 37 C.F.R § 1.97(g) and (h), Applicants make no representation that the information is considered to be material to patentability. Additionally, inclusion on this list is not an admission that any of the cited documents are prior art in this application. Further, Applicants make no representation regarding the completeness of this list, or that better art does not exist.

Applicant wishes to draw the Examiner's attention to the following applications owned by of the present application's assignee:

Docket No.	Serial No.	Patent/ Publication No.	Title	Filed
REDCOM.007A	12/101,882	8,174,560	VIDEO CAMERA	04/11/2008
REDCOM.007CP1	12/422,507	8,237,830	VIDEO CAMERA	04/13/2009
REDCOM.007CP1C1	12/834,854	7,830,967	VIDEO CAMERA	07/12/2010

Application No.: 14/485612
Filing Date: September 12, 2014

Docket No.	Serial No.	Patent/ Publication No.	Title	Filed
REDCOM.007C1	13/464,803	8,872,933	VIDEO CAMERA	05/04/2012
REDCOM.007C2	13/566,868	8,358,357	VIDEO CAMERA	08/03/2012
REDCOM.007CP1C2	13/566,924	8,878,952	VIDEO CAMERA	08/03/2012
REDCOM.007X1 (reexamination REDCOM.007A)	90/012,550	8,174,560 C1	VIDEO CAMERA	09/13/2012
REDCOM.007C3	14/485,611	2015/0003801	VIDEO CAMERA	09/12/2014
REDCOM.007C4	14/485,612	2015/0002695	VIDEO CAMERA	09/12/2014
REDCOM.007P1C3	14/488,030	9,019,393	VIDEO PROCESSING SYSTEM AND METHOD	09/16/2014
REDCOM.007P1C4	14/609,090	N/A	VIDEO CAMERA	01/29/2015

Applicant notes that cited references, office actions, responses and notices of allowance currently exist or will exist for the above-referenced matters. Applicant also understands that the Examiner has access to sophisticated online Patent Office computing systems that provide ready access to the full file histories of these matters including, for example, specifications, drawings, pending claims, cited art, office actions, responses, declarations, and notices of allowance. Rather than submit copies these file histories, Applicant respectfully requests that the Examiner continue to review these file histories online for past, current, and future information about these matters. Also, if the Examiner cannot readily access these file histories, the Applicant would be pleased to provide any portion of any of the file histories at any time upon specific Examiner request.

No Disclaimers

To the extent that anything in the Information Disclosure Statement or the listed references could be construed as a disclaimer of any subject matter supported by the present application, Applicant hereby rescinds and retracts such disclaimer.

Timing of Disclosure

This Information Disclosure Statement is being filed after receipt of a First Office Action, but before the mailing date of a Final Action and before the mailing date of a Notice of Allowance. This Statement is accompanied by the fees set forth in 37 CFR 1.17(p). The

Application No.: 14/485612
Filing Date: September 12, 2014

Commissioner is hereby authorized to charge any additional fees which may be required or to credit any overpayment to Account No. 11-1410.

Respectfully submitted,
KNOBBE, MARTENS, OLSON & BEAR, LLP

Dated: May 18, 2015

By: /Sean Ambrosius/ _____
Sean Ambrosius
Registration No. 65,290
Attorney of Record
Customer No. 20995
(949) 760-0404

20660934

INFORMATION DISCLOSURE STATEMENT BY APPLICANT	Application No.	14/485612
	Filing Date	September 12, 2014
	First Named Inventor	James H. Jannard
	Art Unit	2664
<i>(Multiple sheets used when necessary)</i>	Examiner	Diep, Trung T.
SHEET 1 OF 2	Attorney Docket No.	REDCOM.007C4

U.S. PATENT DOCUMENTS					
Examiner Initials	Cite No.	Document Number <i>Number - Kind Code (if known)</i> Example: 1,234,567 B1	Publication Date MM-DD-YYYY	Name	Pages, Columns, Lines Where Relevant Passages or Relevant Figures Appear
	1	5,132,803	07-21-1992	Suga et al.	
	2	5,172,227	12-15-1992	Tsai et al.	
	3	5,412,427	05-02-1995	Rabbani et al.	
	4	6,169,317	01-02-2001	Sawada et al.	
	5	6,878,977	04-12-2005	Kozuka et al.	
	6	7,902,512	03-08-2011	Chang et al.	
	7	7,952,636	05-31-2011	Ikeda et al.	
	8	8,125,547	02-28-2012	Oda et al.	
	9	8,477,173	07-02-2013	Kenoyer	
	10	8,792,029	07-29-2014	Lee	
	11	8,817,141	08-26-2014	Tanaka	
	12	8,872,933 (and entire prosecution history) (REDCOM.007C1)	10-28-2014	Jannard et al.	
	13	8,878,952 (and entire prosecution history) (REDCOM.007CP1C2)	11-04-2014	Jannard et al.	
	14	9,019,393 (and entire prosecution history) (REDCOM.007P1C3)	04-28-2015	Jannard et al.	
	15	2001/0048477	12-06-2001	Misawa	
	16	2002/0039142	04-04-2002	Zhang et al.	
	17	2002/0167602	11-14-2002	Nguyen	
	18	2004/0201760	10-14-2004	Ota et al.	
	19	2005/0041116	02-24-2005	Tsukioka	
	20	2007/0133902	06-14-2007	Kumar	
	21	2007/0164335	07-19-2007	McKee	
	22	2008/0012953	01-17-2008	Yang et al.	
	23	2008/0063269	03-13-2008	Chiu	
	24	2008/0285871	11-20-2008	Ishikawa	
	25	2009/0033752	02-05-2009	Bodnar et al.	
	26	2009/0086817	04-02-2009	Matsuoka et al.	

Examiner Signature	Date Considered
<p>*Examiner: Initial if reference considered, whether or not citation is in conformance with MPEP 609. Draw line through citation if not in conformance and not considered. Include copy of this form with next communication to applicant.</p>	

T¹ - Place a check mark in this area when an English language Translation is attached.

INFORMATION DISCLOSURE STATEMENT BY APPLICANT	Application No.	14/485612
	Filing Date	September 12, 2014
	First Named Inventor	James H. Jannard
	Art Unit	2664
<i>(Multiple sheets used when necessary)</i>	Examiner	Diep, Trung T.
SHEET 2 OF 2	Attorney Docket No.	REDCOM.007C4

U.S. PATENT DOCUMENTS					
Examiner Initials	Cite No.	Document Number <i>Number - Kind Code (if known)</i> Example: 1,234,567 B1	Publication Date MM-DD-YYYY	Name	Pages, Columns, Lines Where Relevant Passages or Relevant Figures Appear
	27	2010/0225795	09-09-2010	Suzuki et al.	
	28	2011/0194763	08-11-2011	Moon et al.	
	29	2014/0063297	03-06-2014	Yamura	
	30	2014/0161367	06-12-2014	Ridenour et al.	
	31	2014/0218580	08-07-2014	Mayer et al.	
	32	2014/0333810	11-13-2014	Nakaseko	
	33	2015/0003801 (and entire prosecution history) (REDCOM.007C3)	01-01-2015	Jannard et al.	
	34	2015/0092094	04-02-2015	Itonaga et al.	

FOREIGN PATENT DOCUMENTS						
Examiner Initials	Cite No.	Foreign Patent Document <i>Country Code-Number-Kind Code</i> Example: JP 1234567 A1	Publication Date MM-DD-YYYY	Name	Pages, Columns, Lines Where Relevant Passages or Relevant Figures Appear	T ¹
	35	CA 2 831 698	10-23-2008	Red.com, Inc.		
	36	CN 101689357	03-04-2015	Red.com, Inc.		X
	37	JP 2008-124976	05-29-2008	Fujitsu Ltd.		X
	38	KR 10-1478380	12-24-2014	Red.com, Inc.		X
	39	WO 99/012345	03-11-1999	Intel Corporation		

NON PATENT LITERATURE DOCUMENTS			
Examiner Initials	Cite No.	Include name of the author (in CAPITAL LETTERS), title of the article (when appropriate), title of the item (book, magazine, journal, serial, symposium, catalog, etc.), date, page(s), volume-issue number(s), publisher, city and/or country where published.	T ¹
	40	Notice of Opposition in European Application No. 08745686.9 (REDCOM.007VEP), dated April 22, 2015.	
	41	Official Communication in Korean Application No. 10-2014-7021892 (REDCOM.007VKRD1), dated October 10, 2014.	X

20660190

Examiner Signature	Date Considered
* Examiner: Initial if reference considered, whether or not citation is in conformance with MPEP 609. Draw line through citation if not in conformance and not considered. Include copy of this form with next communication to applicant.	

T¹ - Place a check mark in this area when an English language Translation is attached.



(22) **Date de dépôt/Filing Date:** 2008/04/11

(41) **Mise à la disp. pub./Open to Public Insp.:** 2008/10/23

(62) **Demande originale/Original Application:** 2 683 636

(30) **Priorités/Priorities:** 2007/04/11 (US60/911,196);
2007/12/28 (US61/017,406)

(51) **Cl.Int./Int.Cl. H04N 5/30** (2006.01),
H04N 5/378 (2011.01), **H04N 5/917** (2006.01)

(71) **Demandeur/Applicant:**
RED.COM, INC., US

(72) **Inventeurs/Inventors:**
JANNARD, JAMES, US;
NATTRESS, THOMAS GRAEME, CA

(74) **Agent:** PERRY + CURRIER

(54) **Titre : CAMERA VIDEO**

(54) **Title: VIDEO CAMERA**

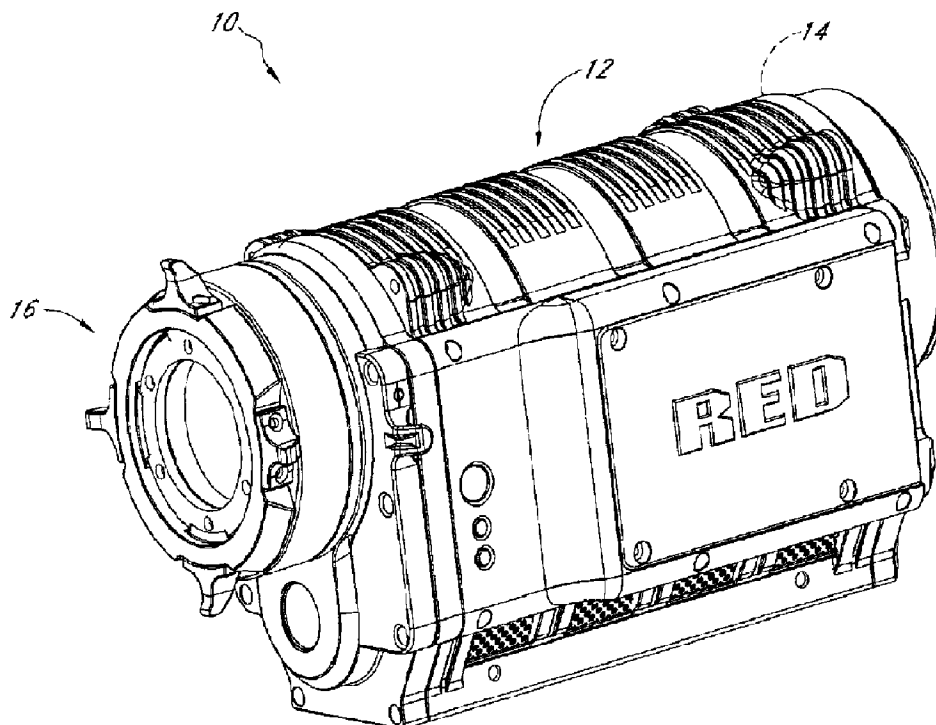

(57) **Abrégé/Abstract:**

A video camera can be configured to highly compress video data in a visually lossless manner. The camera can be configured to transform blue and red image data in a manner that enhances the compressibility of the data. The data can then be compressed and stored in this form. This allows a user to reconstruct the red and blue data to obtain the original raw data for a modified version of the original raw data that is visually lossless when demosaiced. Additionally, the data can be processed in a manner in which the green image elements are demosaiced first and then the red and blue elements are reconstructed based on values of the demosaiced green image elements.

ABSTRACT

A video camera can be configured to highly compress video data in a visually lossless manner. The camera can be configured to transform blue and red image data in a manner that enhances the compressibility of the data. The data can then be compressed and stored in this form. This allows a user to reconstruct the red and blue data to obtain the original raw data for a modified version of the original raw data that is visually lossless when demosaiced. Additionally, the data can be processed in a manner in which the green image elements are demosaiced first and then the red and blue elements are reconstructed based on values of the demosaiced green image elements.

VIDEO CAMERA

BACKGROUND

Field of the Inventions

[0001] The present inventions are directed to digital cameras, such as those for capturing still or moving pictures, and more particularly, to digital cameras that compress image data.

Description of the Related Art

[0002] Despite the availability of digital video cameras, the producers of major motion pictures and some television broadcast media continue to rely film cameras. The film used for such provides video editors with very high resolution images that can be edited by conventional means. More recently, however, such film is often scanned, digitized and digitally edited.

SUMMARY OF THE INVENTIONS

[0003] Although some currently available digital video cameras include high resolution image sensors, and thus output high resolution video, the image processing and compression techniques used on board such cameras are too lossy and thus eliminate too much raw image data to be acceptable in the high end portions of the market noted above. An aspect of at least one of the embodiments disclosed herein includes the realization that video quality that is acceptable for the higher end portions of the markets noted above, such as the major motion picture market, can be satisfied by cameras that can capture and store raw or substantially raw video data having a resolution of at least about 2k and at a frame rate of at least about 23 frames per second.

[0004] Thus, in accordance with an embodiment, a video camera can comprise a portable housing, and a lens assembly supported by the housing and configured to focus light. A light sensitive device can be configured to convert the focused light into raw image data with a resolution of at least 2k at a frame rate of at least about twenty-three frames per second. The camera can also include a memory device and an image processing system configured to compress and store in the memory device the raw image data at a compression

WO 2008/128112

PCT/US2008/060126

ratio of at least six to one and remain substantially visually lossless, and at a rate of at least about 23 frames per second.

[0005] In accordance with another embodiment, a method of recording a motion video with a camera can comprise guiding light onto a light sensitive device. The method can also include converting the light received by the light sensitive device into raw digital image data at a rate of at least greater than twenty three frames per second, compressing the raw digital image data, and recording the raw image data at a rate of at least about 23 frames per second onto a storage device.

[0006] In accordance with yet another embodiment, a video camera can comprise a lens assembly supported by the housing and configured to focus light and a light sensitive device configured to convert the focused light into a signal of raw image data representing the focused light. The camera can also include a memory device and means for compressing and recording the raw image data at a frame rate of at least about 23 frames per second.

[0007] In accordance with yet another embodiment, a video camera can comprise a portable housing having at least one handle configured to allow a user to manipulate the orientation with respect to at least one degree of movement of the housing during a video recording operation of the camera. A lens assembly can comprise at least one lens supported by the housing and configured to focus light at a plane disposed inside the housing. A light sensitive device can be configured to convert the focused light into raw image data with a horizontal resolution of at least 2k and at a frame rate of at least about twenty three frames per second. A memory device can also be configured to store video image data. An image processing system can be configured to compress and store in the memory device the raw image data at a compression ratio of at least six to one and remain substantially visually lossless, and at a rate of at least about 23 frames per second.

[0008] Another aspect of at least one of the inventions disclosed herein includes the realization that because the human eye is more sensitive to green wavelengths than any other color, green image data based modification of image data output from an image sensor can be used to enhance compressibility of the data, yet provide a higher quality video image. One such technique can include subtracting the magnitude of green light detected from the magnitudes of red and/or blue light detected prior to compressing the data. This can convert

the red and/or blue image data into a more compressible form. For example, in the known processes for converting gamma corrected RGB data to Y'CbCr, the image is "decorrelated", leaving most of the image data in the Y' (a.k.a. "luma"), and as such, the remaining chroma components are more compressible. However, the known techniques for converting to the Y'CbCr format cannot be applied directly to Bayer pattern data because the individual color data is not spatially correlated and Bayer pattern data includes twice as much green image data as blue or red image data. The processes of green image data subtraction, in accordance with some of the embodiments disclosed herein, can be similar to the Y'CbCr conversion noted above in that most of the image data is left in the green image data, leaving the remaining data in a more compressible form.

[0009] Further, the process of green image data subtraction can be reversed, preserving all the original raw data. Thus, the resulting system and method incorporating such a technique can provide lossless or visually lossless and enhanced compressibility of such video image data.

[0010] Thus, in accordance with an embodiment, a video camera can comprise a lens assembly supported by the housing and configured to focus light and a light sensitive device configured to convert the focused light into a raw signal of image data representing at least first, second, and third colors of the focused light. An image processing module can be configured to modify image data of at least one of the first and second colors based on the image data of the third color. Additionally, the video camera can include a memory device and a compression device configured to compress the image data of the first, second, and third colors and to store the compressed image data on the memory device.

[0011] In accordance with another embodiment, a method of processing an image can be provided. The method can include converting an image and into first image data representing a first color, second image data representing a second color, and third image data representing a third color, modifying at least the first image data and the second image data based on the third image data, compressing the third image data and the modified first and second image data, and storing the compressed data.

[0012] In accordance with yet another embodiment, a video camera can comprise a lens assembly supported by the housing and configured to focus light. A light sensitive

device can be configured to convert the focused light into a raw signal of image data representing at least first, second, and third colors of the focused light. The camera can also include means for modifying image data of at least one of the first and second colors based on the image data of the third color, a memory device, and a compression device configured to compress the image data of the first, second, and third colors and to store the compressed image data on the memory device.

BRIEF DESCRIPTION OF THE DRAWINGS

[0013] Figure 1 is a block diagram illustrating a system that can include hardware and/or can be configured to perform methods for processing video image data in accordance with an embodiment.

[0014] Figure 2 is an optional embodiment of a housing for the camera schematically illustrated in Figure 1.

[0015] Figure 3 is a schematic layout of an image sensor having a Bayer Pattern Filter that can be used with the system illustrated in Figure 1.

[0016] Figure 4 is a schematic block diagram of an image processing module that can be used in the system illustrated in Figure 1.

[0017] Figure 5 is a schematic layout of the green image data from the green sensor cells of the image sensor of Figure 3.

[0018] Figure 6 is a schematic layout of the remaining green image data of Figure 5 after an optional process of deleting some of the original green image data.

[0019] Figure 7 is a schematic layout of the red, blue, and green image data of Figure 5 organized for processing in the image processing module of Figure 1.

[0020] Figure 8 is a flowchart illustrating an image data transformation technique that can be used with the system illustrated in Figure 1.

[0021] Figure 8A is a flowchart illustrating a modification of the image data transformation technique of Figure 8 that can also be used with the system illustrated in Figure 1.

[0022] Figure 9 is a schematic layout of blue image data resulting from an image transformation process of Figure 8.

[0023] Figure 10 is a schematic layout of red image data resulting from an image transformation process of Figure 8.

[0024] Figure 11 illustrates an exemplary optional transform that can be applied to the image data for gamma correction.

[0025] Figure 12 is a flowchart of a control routine that can be used with the system of Figure 1 to decompress and demosaic image data.

[0026] Figure 12A is a flowchart illustrating a modification of the control routine of Figure 12 that can also be used with the system illustrated in Figure 1.

[0027] Figure 13 is a schematic layout of green image data having been decompressed and demosaiced according to the flowchart of Figure 12.

[0028] Figure 14 is a schematic layout of half of the original green image data from Figure 13, having been decompressed and demosaiced according to the flowchart of Figure 12.

[0029] Figure 15 is a schematic layout of blue image data having been decompressed according to the flowchart of Figure 12.

[0030] Figure 16 is a schematic layout of blue image data of Figure 15 having been demosaiced according to the flowchart of Figure 12.

DETAILED DESCRIPTION OF EMBODIMENTS

[0031] Figure 1 is a schematic diagram of a camera having image sensing, processing, and compression modules, described in the context of a video camera for moving pictures. The embodiments disclosed herein are described in the context of a video camera having a single sensor device with a Bayer pattern filter because these embodiments have particular utility in this context. However, the embodiments and inventions herein can also be applied to cameras having other types of image sensors (e.g., CMY Bayer as well as other non-Bayer patterns), other numbers of image sensors, operating on different image format types, and being configured for still and/or moving pictures. Thus, it is to be understood that the embodiments disclosed herein are exemplary but nonlimiting embodiments, and thus, the inventions disclosed herein are not limited to the disclosed exemplary embodiments.

[0032] With continued reference to Figure 1, a camera 10 can include a body or housing 12 configured to support a system 14 configured to detect, process, and optionally

store and/or replay video image data. For example, the system 14 can include optics hardware 16, an image sensor 18, an image processing module 20, a compression module 22, and a storage device 24. Optionally, the camera 10 can also include a monitor module 26, a playback module 28, and a display 30.

[0033] Figure 2 illustrates a nonlimiting exemplary embodiment of the camera 10. As shown in Figure 2, the optics hardware 16 can be supported by the housing 12 in a manner that leaves it exposed at its outer surface. In some embodiments, the system 14 is supported within the housing 12. For example, the image sensor 18, image processing module 20, and the compression module 22 can be housed within the housing 12. The storage device 24 can be mounted in the housing 12. Additionally, in some embodiments, the storage device 24 can be mounted to an exterior of the housing 12 and connected to the remaining portions of the system 14 through any type of known connector or cable. Additionally, the storage device 24 can be connected to the housing 12 with a flexible cable, thus allowing the storage device 24 to be moved somewhat independently from the housing 12. For example, with such a flexible cable connection, the storage device 24 can be worn on a belt of a user, allowing the total weight of the housing 12 to be reduced. Further, in some embodiments, the housing can include one or more storage devices 24 inside and mounted to its exterior. Additionally, the housing 12 can also support the monitor module 26, and playback module 28. Additionally, in some embodiments, the display 30 can be configured to be mounted to an exterior of the housing 12.

[0034] The optics hardware 16 can be in the form of a lens system having at least one lens configured to focus an incoming image onto the image sensor 18. The optics hardware 16, optionally, can be in the form of a multi-lens system providing variable zoom, aperture, and focus. Additionally, the optics hardware 16 can be in the form of a lens socket supported by the housing 12 and configured to receive a plurality of different types of lens systems for example, but without limitation, the optics hardware 16 include a socket configured to receive various sizes of lens systems including a 50-100 millimeter (F2.8) zoom lens, an 18-50 millimeter (F2.8) zoom lens, a 300 millimeter (F2.8) lens, 15 millimeter (F2.8) lens, 25 millimeter (F1.9) lens, 35 millimeter (F1.9) lens, 50 millimeter (F1.9) lens, 85 millimeter (F1.9) lens, and/or any other lens. As noted above, the optics hardware 16 can be

configured such that despite which lens is attached thereto, images can be focused upon a light-sensitive surface of the image sensor 18.

[0035] The image sensor 18 can be any type of video sensing device, including, for example, but without limitation, CCD, CMOS, vertically-stacked CMOS devices such as the Foveon® sensor, or a multi-sensor array using a prism to divide light between the sensors. In some embodiments, the image sensor 18 can include a CMOS device having about 12 million photocells. However, other size sensors can also be used. In some configurations, camera 10 can be configured to output video at “2k” (e.g., 2048 x 1152 pixels), “4k” (e.g., 4,096 x 2,540 pixels), “4.5k” horizontal resolution or greater resolutions. As used herein, in the terms expressed in the format of xk (such as 2k and 4k noted above), the “x” quantity refers to the approximate horizontal resolution. As such, “4k” resolution corresponds to about 4000 or more horizontal pixels and “2k” corresponds to about 2000 or more pixels. Using currently commercially available hardware, the sensor can be as small as about 0.5 inches (8 mm), but it can be about 1.0 inches, or larger. Additionally, the image sensor 18 can be configured to provide variable resolution by selectively outputting only a predetermined portion of the sensor 18. For example, the sensor 18 and/or the image processing module can be configured to allow a user to identify the resolution of the image data output.

[0036] The camera 10 can also be configured to downsample and subsequently process the output of the sensor 18 to yield video output at 2K, 1080p, 720p, or any other resolution. For example, the image data from the sensor 18 can be “windowed”, thereby reducing the size of the output image and allowing for higher readout speeds. However, other size sensors can also be used. Additionally, the camera 10 can be configured to upsample the output of the sensor 18 to yield video output at higher resolutions.

[0037] With reference to Figure 1 and 3, in some embodiments, the sensor 18 can include a Bayer pattern filter. As such, the sensor 18, by way of its chipset (not shown) outputs data representing magnitudes of red, green, or blue light detected by individual photocells of the image sensor 18. Figure 3 schematically illustrates the Bayer pattern output of the sensor 18. In some embodiments, for example, as shown in Figure 3, the Bayer pattern filter has twice as many green elements as the number of red elements and the number of blue

elements. The chipset of the image sensor 18 can be used to read the charge on each element of the image sensor and thus output a stream of values in the well-known RGB format output.

[0038] With continued reference to Figure 4, the image processing module 20 optionally can be configured to format the data stream from the image sensor 18 in any known manner. In some embodiments, the image processing module 20 can be configured to separate the green, red, and blue image data into three or four separate data compilations. For example, the image processing module 20 can be configured to separate the red data into one data element, the blue data into one blue data element, and the green data into one green data element. For example, with reference to Figure 4, the image processing module 20 can include a red data processing module 32, a blue data image processing module 34, and a first green image data processing module 36.

[0039] As noted above, however, the Bayer pattern data illustrated in Figure 3, has twice as many green pixels as the other two colors. Figure 5 illustrates a data component with the blue and red data removed, leaving only the original green image data.

[0040] In some embodiments, the camera 10 can be configured to delete or omit some of the green image data. For example, in some embodiments, the image processing module 20 can be configured to delete 1/2 of the green image data so that the total amount of green image data is the same as the amounts of blue and red image data. For example, Figure 6 illustrates the remaining data after the image processing module 20 deletes 1/2 of the green image data. In the illustrated embodiment of Figure 6, the rows n-3, n-1, n+1, and n+3 have been deleted. This is merely one example of the pattern of green image data that can be deleted. Other patterns and other amounts of green image data can also be deleted.

[0041] In some alternatives, the camera 10 can be configured to delete 1/2 of the green image data after the red and blue image data has been transformed based on the green image data. This optional technique is described below following the description of the subtraction of green image data values from the other color image data.

[0042] Optionally, the image processing module 20 can be configured to selectively delete green image data. For example, the image processing module 20 can include a deletion analysis module (not shown) configured to selectively determine which green image data to delete. For example, such a deletion module can be configured to

WO 2008/128112

PCT/US2008/060126

determine if deleting a pattern of rows from the green image data would result in aliasing artifacts, such as Moiré lines, or other visually perceptible artifacts. The deletion module can be further configured to choose a pattern of green image data to delete that would present less risk of creating such artifacts. For example, the deletion module can be configured to choose a green image data deletion pattern of alternating vertical columns if it determines that the image captured by the image sensor 18 includes an image feature characterized by a plurality of parallel horizontal lines. This deletion pattern can reduce or eliminate artifacts, such as Moiré lines, that might have resulted from a deletion pattern of alternating lines of image data parallel to the horizontal lines detected in the image.

[0043] However, this merely one exemplary, non-limiting example of the types of image features and deletion patterns that can be used by the deletion module. The deletion module can also be configured to detect other image features and to use other image data deletion patterns, such as for example, but without limitation, deletion of alternating rows, alternating diagonal lines, or other patterns. Additionally, the deletion module can be configured to delete portions of the other image data, such as the red and blue image data, or other image data depending on the type of sensor used.

[0044] Additionally, the camera 10 can be configured to insert a data field into the image data indicating what image data has been deleted. For example, but without limitation, the camera 10 can be configured to insert a data field into the beginning of any video clip stored into the storage device 24, indicating what data has been deleted in each of the "frames" of the video clip. In some embodiments, the camera can be configured to insert a data field into each frame captured by the sensor 18, indicating what image data has been deleted. For example, in some embodiments, where the image processing module 20 is configured to delete ½ of the green image data in one deletion pattern, the data field can be as small as a single bit data field, indicating whether or not image data has been deleted. Since the image processing module 20 is configured to delete data in only one pattern, a single bit is sufficient to indicate what data has been deleted.

[0045] In some embodiments, as noted above, the image processing module 20 can be configured to selectively delete image data in more than one pattern. Thus, the image data deletion field can be larger, including a sufficient number of values to provide an

indication of which of the plurality of different image data deletion patterns was used. This data field can be used by downstream components and or processes to determine to which spacial positions the remaining image data corresponds.

[0046] In some embodiments, the image processing module can be configured to retain all of the raw green image data, e.g., the data shown in Figure 5. In such embodiments, the image processing module can include one or more green image data processing modules.

[0047] As noted above, in known Bayer pattern filters, there are twice as many green elements as the number of red elements and the number of blue elements. In other words, the red elements comprise 25% of the total Bayer pattern array, the blue elements corresponded 25% of the Bayer pattern array and the green elements comprise 50% of the elements of the Bayer pattern array. Thus, in some embodiments, where all of the green image data is retained, the image processing module 20 can include a second green data image processing module 38. As such, the first green data image processing module 36 can process half of the green elements and the second green image data processing module 38 can process the remaining green elements. However, the present inventions can be used in conjunction with other types of patterns, such as for example, but without limitation, CMY and RGBW.

[0048] Figure 7 includes schematic illustrations of the red, blue and two green data components processed by modules 32, 34, 36, and 38 (Figure 4). This can provide further advantages because the size and configuration of each of these modules can be about the same since they are handling about the same amount of data. Additionally, the image processing module 20 can be selectively switched between modes in which is processes all of the green image data (by using both modules 36 and 38) and modes where $\frac{1}{2}$ of the green image data is deleted (in which it utilizes only one of modules 36 and 38). However, other configurations can also be used.

[0049] Additionally, in some embodiments, the image processing module 20 can include other modules and/or can be configured to perform other processes, such as, for example, but without limitation, gamma correction processes, noise filtering processes, etc.

[0050] Additionally, in some embodiments, the image processing module 20 can be configured to subtract a value of a green element from a value of a blue element and/or red

element. As such, in some embodiments, when certain colors are detected by the image sensor 18, the corresponding red or blue element can be reduced to zero. For example, in many photographs, there can be large areas of black, white, or gray, or a color shifted from gray toward the red or blue colors. Thus, if the corresponding pixels of the image sensor 18 have sensed an area of gray, the magnitude of the green, red, and blue, would be about equal. Thus, if the green value is subtracted from the red and blue values, the red and blue values will drop to zero or near zero. Thus, in a subsequent compression process, there will be more zeros generated in pixels that sense a black, white, or gray area and thus the resulting data will be more compressible. Additionally, the subtraction of green from one or both of the other colors can make the resulting image data more compressible for other reasons.

[0051] Such a technique can help achieve a higher effective compression ratio and yet remain visually lossless due to its relationship to the entropy of the original image data. For example, the entropy of an image is related to the amount of randomness in the image. The subtraction of image data of one color, for example, from image data of the other colors can reduce the randomness, and thus reduce the entropy of the image data of those colors, thereby allowing the data to be compressed at higher compression ratios with less loss. Typically, an image is not a collection of random color values. Rather, there is often a certain degree of correlation between surrounding picture elements. Thus, such a subtraction technique can use the correlation of picture elements to achieve better compression. The amount of compression will depend, at least in part, on the entropy of the original information in the image.

[0052] In some embodiments, the magnitudes subtracted from a red or blue pixel can be the magnitude of the value output from a green pixel adjacent to the subject red or blue pixel. Further, in some embodiments, the green magnitude subtracted from the red or blue elements can be derived from an average of the surrounding green elements. Such techniques are described in greater detail below. However, other techniques can also be used.

[0053] Optionally, the image processing module 20 can also be configured to selectively subtract green image data from the other colors. For example, the image processing module 20 can be configured to determine if subtracting green image data from a portion of the image data of either of the other colors would provide better compressibility or

not. In this mode, the image processing module 20 can be configured to insert flags into the image data indicating what portions of the image data has been modified (by e.g., green image data subtraction) and which portions have not been so modified. With such flags, a downstream demosaicing/reconstruction component can selectively add green image values back into the image data of the other colors, based on the status of such data flags.

[0054] Optionally, image processing module 20 can also include a further data reduction module (not shown) configured to round values of the red and blue data. For example, if, after the subtraction of green magnitudes, the red or blue data is near zero (e.g., within one or two on an 8-bit scale ranging from 0-255 or higher magnitudes for a higher resolution system). For example, the sensor 18 can be a 12-bit sensor outputting red, blue, and green data on a scale of 0-4095. Any rounding or filtering of the data performed the rounding module can be adjusted to achieve the desired effect. For example, rounding can be performed to a lesser extent if it is desired to have lossless output and to a greater extent if some loss or lossy output is acceptable. Some rounding can be performed and still result in a visually lossless output. For example, on a 8-bit scale, red or blue data having absolute value of up to 2 or 3 can be rounded to 0 and still provide a visually lossless output. Additionally, on a 12-bit scale, red or blue data having an absolute value of up to 10 to 20 can be rounded to 0 and still provide visually lossless output.

[0055] Additionally, the magnitudes of values that can be rounded to zero, or rounded to other values, and still provide a visually lossless output depends on the configuration of the system, including the optics hardware 16, the image sensor 18, the resolution of the image sensor, the color resolution (bit) of the image sensor 18, the types of filtering, anti-aliasing techniques or other techniques performed by the image processing module 20, the compression techniques performed by the compression module 22, and/or other parameters or characteristics of the camera 10.

[0056] As noted above, in some embodiments, the camera 10 can be configured to delete $\frac{1}{2}$ of the green image data after the red and blue image data has been transformed based on the green image data. For example, but without limitation, the processor module 20 can be configured to delete $\frac{1}{2}$ of the green image data after the average of the magnitudes of the surrounding green data values have been subtracted from the red and blue data values.

WO 2008/128112

PCT/US2008/060126

This reduction in the green data can reduce throughput requirements on the associated hardware. Additionally, the remaining green image data can be used to reconstruct the red and blue image data, described in greater detail below with reference to Figures 14 and 16.

[0057] As noted above, the camera 10 can also include a compression module 22. The compression module 22 can be in the form of a separate chip or it can be implemented with software and another processor. For example, the compression module 22 can be in the form of a commercially available compression chip that performs a compression technique in accordance with the JPEG 2000 standard, or other compression techniques.

[0058] The compression module can be configured to perform any type of compression process on the data from the image processing module 20. In some embodiments, the compression module 22 performs a compression technique that takes advantage of the techniques performed by the image processing module 20. For example, as noted above, the image processing module 20 can be configured to reduce the magnitude of the values of the red and blue data by subtracting the magnitudes of green image data, thereby resulting in a greater number of zero values, as well as other effects. Additionally, the image processing module 20 can perform a manipulation of raw data that uses the entropy of the image data. Thus, the compression technique performed by the compression module 22 can be of a type that benefits from the presence of larger strings of zeros to reduce the size of the compressed data output therefrom.

[0059] Further, the compression module 22 can be configured to compress the image data from the image processing module 20 to result in a visually lossless output. For example, firstly, the compression module can be configured to apply any known compression technique, such as, but without limitation, JPEG 2000, MotionJPEG, any DCT based codec, any codec designed for compressing RGB image data, H.264, MPEG4, Huffman, or other techniques.

[0060] Depending on the type of compression technique used, the various parameters of the compression technique can be set to provide a visually lossless output. For example, many of the compression techniques noted above can be adjusted to different compression rates, wherein when decompressed, the resulting image is better quality for lower compression rates and lower quality for higher compression rates. Thus, the

WO 2008/128112

PCT/US2008/060126

compression module can be configured to compress the image data in a way that provides a visually lossless output, or can be configured to allow a user to adjust various parameters to obtain a visually lossless output. For example, the compression module 22 can be configured to compress the image data at a compression ratio of about 6:1, 7:1, 8:1 or greater. In some embodiments, the compression module 22 can be configured to compress the image data to a ratio of 12:1 or higher.

[0061] Additionally, the compression module 22 can be configured to allow a user to adjust the compression ratio achieved by the compression module 22. For example, the camera 10 can include a user interface that allows a user to input commands that cause the compression module 22 to change the compression ratio. Thus, in some embodiments, the camera 10 can provide for variable compression.

[0062] As used herein, the term “visually lossless” is intended to include output that, when compared side by side with original (never compressed) image data on the same display device, one of ordinary skill in the art would not be able to determine which image is the original with a reasonable degree of accuracy, based only on a visual inspection of the images.

[0063] With continued reference to Figure 1, the camera 10 can also include a storage device 24. The storage device can be in the form of any type of digital storage, such as, for example, but without limitation, hard disks, flash memory, or any other type of memory device. In some embodiments, the size of the storage device 24 can be sufficiently large to store image data from the compression module 22 corresponding to at least about 30 minutes of video at 12 mega pixel resolution, 12-bit color resolution, and at 60 frames per second. However, the storage device 24 can have any size.

[0064] In some embodiments, the storage device 24 can be mounted on an exterior of the housing 12. Further, in some embodiments, the storage device 24 can be connected to the other components of the system 14 through standard communication ports, including, for example, but without limitation, IEEE 1394, USB 2.0, IDE, SATA, etc. Further, in some embodiments, the storage device 24 can comprise a plurality of hard drives operating under a RAID protocol. However, any type of storage device can be used.

WO 2008/128112

PCT/US2008/060126

[0065] With continued reference to Figure 1, as noted above, in some embodiments, the system can include a monitor module 26 and a display device 30 configured to allow a user to view video images captured by the image sensor 18 during operation. In some embodiments, the image processing module 20 can include a subsampling system configured to output reduced resolution image data to the monitor module 26. For example, such a subsampling system can be configured to output video image data to support 2K, 1080p, 720p, or any other resolution. In some embodiments, filters used for demosaicing can be adapted to also perform downsampling filtering, such that downsampling and filtering can be performed at the same time. The monitor module 26 can be configured to perform any type of demosaicing process to the data from the image processing module 20. Thereafter, the monitor module 26 can output a demosaiced image data to the display 30.

[0066] The display 30 can be any type of monitoring device. For example, but without limitation, the display 30 can be a four-inch LCD panel supported by the housing 12. For example, in some embodiments, the display 30 can be connected to an infinitely adjustable mount configured to allow the display 30 to be adjusted to any position relative to the housing 12 so that a user can view the display 30 at any angle relative to the housing 12. In some embodiments, the display 30 can be connected to the monitor module through any type of video cables such as, for example, an RGB or YCC format video cable.

[0067] Optionally, the playback module 28 can be configured to receive data from the storage device 24, decompressed and demosaic the image data and then output the image data to the display 30. In some embodiments, the monitor module 26 and the playback module 28 can be connected to the display through an intermediary display controller (not shown). As such, the display 30 can be connected with a single connector to the display controller. The display controller can be configured to transfer data from either the monitor module 26 or the playback module 28 to the display 30.

[0068] Figure 8 includes a flowchart 50 illustrating the processing of image data by the camera 10. In some embodiments, the flowchart 50 can represent a control routine stored in a memory device, such as the storage device 24, or another storage device (not shown) within the camera 10. Additionally, a central processing unit (CPU) (not shown) can

be configured to execute the control routine. The below description of the methods corresponding to the flow chart 50 are described in the context of the processing of a single frame of video image data. Thus, the techniques can be applied to the processing of a single still image. These processes can also be applied to the processing of continuous video, e.g., frame rates of greater than 12, as well as frame rates of 20, 23.976, 24, 30, 60, and 120, or other frame rates between these frame rates or greater.

[0069] With continued reference to Figure 8, control routine can begin at operation block 52. In the operation block 52, the camera 10 can obtain sensor data. For example, with reference to Figure 1, the image sensor 18, which can include a Bayer Sensor and chipset, can output image data.

[0070] For example, but without limitation, with reference to Figure 3, the image sensor can comprise a CMOS device having a Bayer pattern filter on its light receiving surface. Thus, the focused image from the optics hardware 16 is focused on the Bayer pattern filter on the CMOS device of the image sensor 18. Figure 3 illustrates an example of the Bayer pattern created by the arrangement of Bayer pattern filter on the CMOS device.

[0071] In Figure 3, column m is the fourth column from the left edge of the Bayer pattern and row n is the fourth row from the top of the pattern. The remaining columns and rows are labeled relative to column m and row n . However, this layout is merely chosen arbitrarily for purposes of illustration, and does not limit any of the embodiments or inventions disclosed herein.

[0072] As noted above, known Bayer pattern filters often include twice as many green elements as blue and red elements. In the pattern of figure 5, blue elements only appear in rows $n-3$, $n-1$, $n+1$, and $n+3$. Red elements only appear in rows $n-2$, n , $n+2$, and $n+4$. However, green elements appear in all rows and columns, interspersed with the red and blue elements.

[0073] Thus, in the operation block 52, the red, blue, and green image data output from the image sensor 18 can be received by the image processing module 20 and organized into separate color data components, such as those illustrated in Figure 7. As shown in Figure 7, and as described above with reference to Figure 4, the image processing module 20 can separate the red, blue, and green image data into four separate components. Figure 7

illustrates two green components (Green 1 and Green 2), a blue component, and a red component. However, this is merely one exemplary way of processing image data from the image sensor 18. Additionally, as noted above, the image processing module 20, optionally, can arbitrarily or selectively delete $\frac{1}{2}$ of the green image data.

[0074] After the operation block 52, the flowchart 50 can move on to operation block 54. In the operation block 56, the image data can be further processed. For example, optionally, any one or all of the resulting data (e.g., green 1, green 2, the blue image data from Figure 9, and the red image data from Figure 10) can be further processed.

[0075] For example, the image data can be pre-emphasized or processed in other ways. In some embodiments, the image data can be processed to be more (mathematically) non-linear. Some compression algorithms benefit from performing such a linearization on the picture elements prior to compression. However, other techniques can also be used. For example, the image data can be processed with a linear curve, which provides essentially no emphasis.

[0076] In some embodiments, the operation block 54 can process the image data using curve defined by the function $y=x^{0.5}$. In some embodiments, this curve can be used where the image data was, for example but without limitation, floating point data in the normalized 0-1 range. In other embodiments, for example, where the image data is 12-bit data, the image can be processed with the curve $y=(x/4095)^{0.5}$. Additionally, the image data can be processed with other curves, such as $y=(x+c)^g$ where $0.01 < g < 1$ and c is an offset, which can be 0 in some embodiments. Additionally, log curves can also be used. For example, curves in the form $y=A*\log(B*x+C)$ where A , B , and C are constants chosen to provide the desired results. Additionally, the above curves and processes can be modified to provide more linear areas in the vicinity of black, similar to those techniques utilized in the well-known Rec709 gamma curve. In applying these processes to the image data, the same processes can be applied to all of the image data, or different processes can be applied to the different colors of image data. However, these are merely exemplary curves that can be used to process the image data, or curves or transforms can also be used. Additionally, these processing techniques can be applied using mathematical functions such as those noted above, or with Look Up Tables (LUTs). Additionally, different processes, techniques, or

transforms can be used for different types of image data, different ISO settings used during recording of the image data, temperature (which can affect noise levels), etc.

[0077] After the operation block 54, the flowchart 50 can move to an operation block 56. In the operation block 56, the red and blue picture elements can be transformed. For example, as noted above, green image data can be subtracted from each of the blue and red image data components. In some embodiments, a red or blue image data value can be transformed by subtracting a green image data value of at least one of the green picture elements adjacent to the red or blue picture element. In some embodiments, an average value of the data values of a plurality of adjacent green picture elements can be subtracted from the red or blue image data value. For example, but without limitation, average values of 2, 3, 4, or more green image data values can be calculated and subtracted from red or blue picture elements in the vicinity of the green picture elements.

[0078] For example, but without limitation, with reference to Figure 3, the raw output for the red element $R_{m-2,n-2}$ is surrounded by four green picture elements $G_{m-2,n-3}$, $G_{m-1,n-2}$, $G_{m-3,n-2}$, and $G_{m-2,n-1}$. Thus, the red element $R_{m-2,n-2}$ can be transformed by subtracting the average of the values of the surrounding green element as follows:

$$(1) \quad R_{m,n} = R_{m,n} - (G_{m,n-1} + G_{m+1,n} + G_{m,n+1} + G_{m-1,n})/4$$

[0079] Similarly, the blue elements can be transformed in a similar manner by subtracting the average of the surrounding green elements as follows:

$$(2) \quad B_{m+1,n+1} = B_{m+1,n+1} - (G_{m+1,n} + G_{m+2,n+1} + G_{m+1,n+2} + G_{m,n+1})/4$$

[0080] Figure 9 illustrates a resulting blue data component where the original blue raw data $B_{m-1,n-1}$ is transformed, the new value labeled as $B'_{m-1,n-1}$ (only one value in the component is filled in and the same technique can be used for all the blue elements). Similarly, Figure 10 illustrates the red data component having been transformed in which the transformed red element $R_{m-2,n-2}$ is identified as $R'_{m-2,n-2}$. In this state, the image data can still be considered "raw" data. For example, the mathematical process performed on the data are entirely reversible such that all of the original values can be obtained by reversing those processes.

[0081] With continued reference to Figure 8, after the operation block 56, the flowchart 50 can move on to an operation block 58. In the operation block 58, the resulting

data, which is raw or can be substantially raw, can be further compressed to using any known compression algorithm. For example, the compression module 22 (Figure 1) can be configured to perform such a compression algorithm. After compression, the compressed raw data can be stored in the storage device 24 (Figure 1).

[0082] Figure 8A illustrates a modification of the flowchart 50, identified by the reference numeral 50'. Some of the steps described above with reference to the flowchart 50 can be similar or the same as some of the corresponding steps of the flowchart 50' and thus are identified with the same reference numerals.

[0083] As shown in Figure 8A, the flowchart 50', in some embodiments, can optionally omit operation block 54. In some embodiments, the flowchart 50' can also include an operation block 57 in which a look up table can be applied to the image data. For example, an optional look-up table, represented by the curve of Figure 11, can be used to enhance further compression. In some embodiments, the look-up table of Figure 11 is only used for the green picture elements. In other embodiments, the look-up table can also be used for red and blue picture elements. The same look-up table may be used for the three different colors, or each color may have its own look-up table. Additionally, processes other than that represented by the curve of Figure 11 can also be applied.

[0084] By processing the image data in the manner described above with reference to Figures 8 and 8A, it has been discovered that the image data from the image sensor 18 can be compressed by a compression ratio of 6 to 1 or greater and remain visually lossless. Additionally, although the image data has been transformed (e.g., by the subtraction of green image data) all of the raw image data is still available to an end user. For example, by reversing certain of the processes, all or substantially all of the original raw data can be extracted and thus further processed, filtered, and/or demosaiced using any process the user desires.

[0085] For example, with reference to Figure 12, the data stored in the storage device 24 can be decompressed and demosaiced. Optionally, the camera 10 can be configured to perform the method illustrated by flowchart 60. For example, but without limitation, the playback module 28 can be configured to perform the method illustrated by

WO 2008/128112

PCT/US2008/060126

flowchart 60. However, a user can also transfer the data from the storage device 24 into a separate workstation and apply any or all of the steps and/or operations of the flowchart 60.

[0086] With continued reference to Figure 12, the flowchart 60 can begin with the operation block 62, in which the data from the storage device 24 is decompressed. For example, the decompression of the data in operation block 62 can be the reverse of the compression algorithm performed in operational block 58 (Figure 8). After the operation block 62, the flowchart 60 can move on to an operation block 64.

[0087] In the operation block 64, a process performed in operation block 56 (Figure 8) can be reversed. For example, the inverse of the curve of Figure 11 or the inverse of any of the other functions described above with reference to operation block 56 of Figures 8 and 8A, can be applied to the image data. After the operation block 64, the flowchart 60 can move on to a step 66.

[0088] In the operation block 66, the green picture elements can be demosaiced. For example, as noted above, all the values from the data components Green 1 and/or Green 2 (Figure 7) can be stored in the storage device 24. For example, with reference to Figure 5, the green image data from the data components Green 1, Green 2 can be arranged according to the original Bayer pattern applied by the image sensor 18. The green data can then be further demosaiced by any known technique, such as, for example, linear interpolation, bilinear, etc.

[0089] Figure 13 illustrates an exemplary layout of green image data demosaiced from all of the raw green image data. The green image elements identified with the letter G_x represent original raw (decompressed) image data and the elements identified with "DG $_x$ " represent elements that were derived from the original data through the demosaic process. This nomenclature is used with regard to the below descriptions of the demosaicing process for the other colors. Figure 14 illustrates an exemplary image data layout for green image data demosaiced from $\frac{1}{2}$ of the original green image data.

[0090] With continued reference to Figure 12, the flowchart 60 can, after the operation block 66, move on to an operation block 68. In the operation block 68, the demosaiced green image data can be further processed. For example, but without limitation, noise reduction techniques can be applied to the green image data. However, any other image

processing technique, such as anti-aliasing techniques, can also be applied to the green image data. After the operation block 68, the flowchart 60 can move on to an operation block 70.

[0091] In the operation block 70, the red and blue image data can be demosaiced. For example, firstly, the blue image data of Figure 9 can be rearranged according to the original Bayer pattern (Figure 15). The surrounding elements, as shown in Figure 16, can be demosaiced from the existing blue image data using any known demosaicing technique, including linear interpolation, bilinear, etc. As a result of demosaicing step, there will be blue image data for every pixel as shown in Figure 16. However, this blue image data was demosaiced based on the modified blue image data of Figure 9, i.e., blue image data values from which green image data values were subtracted.

[0092] The operation block 70 can also include a demosaicing process of the red image data. For example, the red image data from Figure 10 can be rearranged according to the original Bayer pattern and further demosaiced by any known demosaicing process such as linear interpolation, bilinear, etc.

[0093] After the operation block 70, the flowchart can move on to an operation block 72. In the operation block 72, the demosaiced red and blue image data can be reconstructed from the demosaiced green image data.

[0094] In some embodiments, each of the red and blue image data elements can be reconstructed by adding in the green value from co-sited green image element (the green image element in the same column "m" and row "n" position). For example, after demosaicing, the blue image data includes a blue element value $DB_{m-2,n-2}$. Because the original Bayer pattern of Figure 3 did not include a blue element at this position, this blue value $DB_{m-2,n-2}$ was derived through the demosaicing process noted above, based on, for example, blue values from any one of the elements $B_{m-3,n-3}$, $B_{m-1,n-3}$, $B_{m-3,n-1}$, and $B_{m-1,n-1}$ or by any other technique or other blue image elements. As noted above, these values were modified in operation block 54 (Figure 8) and thus do not correspond to the original blue image data detected by the image sensor 18. Rather, an average green value had been subtracted from each of these values. Thus, the resulting blue image data $DB_{m-2,n-2}$ also represents blue data from which green image data has been subtracted. Thus, in one

embodiment, the demosaiced green image data for element $DG_{m-2,n-2}$ can be added to the blue image value $DB_{m-2,n-2}$ thereby resulting in a reconstructed blue image data value.

[0095] In some embodiments, optionally, the blue and/or red image data can first be reconstructed before demosaicing. For example, the transformed blue image data $B'_{m-1,n-1}$ can be first reconstructed by adding the average value of the surrounding green elements. This would result in obtaining or recalculating the original blue image data $B_{m-1,n-1}$. This process can be performed on all of the blue image data. Subsequently, the blue image data can be further demosaiced by any known demosaicing technique. The red image data can also be processed in the same or similar manners.

[0096] Figure 12A illustrates a modification of the flowchart 60, identified by the reference numeral 60'. Some of the steps described above with reference to the flowchart 60 can be similar or the same as some of the corresponding steps of the flowchart 60' and thus are identified with the same reference numerals.

[0097] As shown in Figure 12A, the flow chart 60' can include the operation block 68' following operation block 62. In operation block 68', a noise reduction technique can be performed on the image data. For example, but without limitation, noise reduction techniques can be applied to the green image data. However, any other image processing technique, such as anti-aliasing techniques, can also be applied to the green image data. After operation block 68', the flow chart can move on to operation block 70'

[0098] In operation block 70', the image data can be demosaiced. In the description set forth above with reference to operation blocks 66 and 70, the green, red, and blue image data can be demosaiced in two steps. However, in the present flow chart 60', the demosaicing of all three colors of image data is represented in a single step, although the same demosaicing techniques described above can be used for this demosaicing process. After the operation block 70', the flow chart can move on to operation block 72, in which the red and blue image data can be reconstructed, and operation block 64 in which an inverse look-up table can be applied.

[0099] After the image data has been decompressed and processed according to either of the flow charts 70 or 70', or any other suitable process, the image data can be further processed as demosaiced image data.

WO 2008/128112

PCT/US2008/060126

[0100] By demosaicing the green image data before reconstructing the red and blue image data, certain further advantages can be achieved. For example, as noted above, the human eye is more sensitive to green light. Demosaicing and processing the green image data optimize the green image values, to which the human eye is more sensitive. Thus, the subsequent reconstruction of the red and blue image data will be affected by the processing of the green image data.

[0101] Additionally, Bayer patterns have twice as many green elements as red and blue elements. Thus, in embodiments where all of the green data is retained, there is twice as much image data for the green elements as compared to either the red or blue image data elements. Thus, the demosaicing techniques, filters, and other image processing techniques result in a better demosaiced, sharpened, or otherwise filtered image. Using these demosaiced values to reconstruct and demosaic the red and blue image data transfers the benefits associated with the higher resolution of the original green data to the process, reconstruction, and demosaicing of the red and blue elements. As such, the resulting image is further enhanced.

WHAT IS CLAIMED IS:

1. A video camera comprising:
 - a portable housing;
 - a lens assembly supported by the housing and configured to focus light;
 - a light sensitive device configured to convert the focused light into raw image data with a resolution of at least 2k at a frame rate of at least about twenty-three frames per second;
 - a memory device; and
 - an image processing system configured to compress and store in the memory device the raw image data at a compression ratio of at least six to one and remain substantially visually lossless, and at a rate of at least about 23 frames per second.
2. A video camera according to Claim 1, wherein the image processing system further comprises an image processing module configured to modify the image data representing at least one of the first and second colors based on the image data of the third color.
3. A video camera according to Claim 2, wherein the third color is green.
4. A video camera according to Claim 2, wherein the image processing module is configured to subtract a value of the image data of the third color from values of the image data of the first and second colors.
5. A video camera according to Claim 2, wherein the image processing system is configured to compress the image data of the first, second, and third colors after the image processing module has modified the image data representing at least one of the first and second colors.
6. A video camera according to Claim 2, wherein the image processing system is configured to delete about half of the image data representing the third color.
7. A video camera according to Claim 6, wherein the light sensitive device includes a first group of sensor cells configured to detect the first color, a second group of sensor cells configured to detect the second color, and a third group of sensor cells configured to detect the third color, the third group of sensor cells comprising twice as many sensor cells as the second group of sensor cells.

WO 2008/128112

PCT/US2008/060126

8. A video camera according to Claim 1, wherein the memory device is disposed within the housing.
9. A video camera according to Claim 1, wherein the memory device is supported on the outside of the housing.
10. A video camera according to Claim 1, wherein the memory device is connected to the housing with a flexible cable.
11. A video camera according to Claim 1, wherein the image processing system is configured to manipulate the raw image data so as to reduce an entropy of the raw image data before compression.
12. A video camera according to Claim 1, wherein the image processing system is configured to reduce an entropy of the raw image data before compression.
13. A video camera comprising:
 - a lens assembly supported by the housing and configured to focus light;
 - a light sensitive device configured to convert the focused light into a raw signal of image data representing at least first, second, and third colors of the focused light;
 - an image processing module configured to modify image data of at least one of the first and second colors based on the image data of the third color;
 - a memory device; and
 - a compression device configured to compress the image data of the first, second, and third colors and to store the compressed image data on the memory device at a frame rate of at least about 23 frames per second.
14. A video camera according to Claim 13, wherein the third color is green.
15. A video camera according to Claim 13, wherein the image processing module is configured to subtract the values of the image data of the third color from the values of image data of at least one of the first and second colors.
16. A video camera according to Claim 15, wherein the values of the image data of the third color comprise an average of values of selected image data of the third color.
17. A video camera according to Claim 13, wherein the image processing module is configured to calculate an average of values of image data of the third color from at least

two sensor cells adjacent to a sensor cell of the first color and to subtract the average value from a value of the image data from the sensor cell of the first color.

18. A video camera according to Claim 17, wherein the average of values comprises the average of values of image data of the third color from at least for sensor cells adjacent to the sensor cell of the first color.

19. A video camera according to Claim 13, wherein the light sensitive device comprises a Bayer sensor.

20. A method of recording a motion video with a camera, the method comprising:
guiding light onto a light sensitive device;
converting the light received by the light sensitive device into raw digital image data at a rate of at least greater than twenty three frames per second;
compressing the raw digital image data; and
recording the raw image data at a rate of at least about 23 frames per second onto a storage device.

21. The method according to Claim 20, wherein the step of compressing the raw digital image data comprises compressing the raw digital image data to an effective compression ratio of at least 6 to 1.

22. The method according to Claim 20, wherein the step of compressing the raw digital image data comprises compressing the raw digital image data with an effective compression ratio of at least about 12:1.

23. The method according to Claim 20, wherein the step of compressing the raw digital image data comprises compressing the raw digital image data such that the data remains visually lossless.

24. The method according to Claim 20, wherein the step of recording comprises storing the compressed raw digital image data.

25. The method according to Claim 20, wherein the step of recording comprises recording the raw image data at a rate of at least about 23.976 frames per second onto the storage device.

WO 2008/128112

PCT/US2008/060126

26. The method according to Claim 20 additionally comprising a step of manipulating the raw image data to reduce an entropy of the raw image data, before the step of recording.

27. The method according to Claim 20 additionally comprising a step of reducing an entropy of the raw image data, before the step of recording.

28. The method according to Claim 27 additionally comprising a step of compressing the raw image data in a visually lossless manner after the step of reducing an entropy.

29. A method of processing an image, comprising:

converting an image and into raw first image data representing a first color, raw second image data representing a second color, and raw third image data representing a third color;

modifying at least the raw first image data and the raw second image data based on the raw third image data;

compressing the raw third image data and the modified raw first and raw second image data; and

storing the compressed data at a frame rate of at least about 23 frames per second.

30. The method according to Claim 29, wherein the step of storing comprises storing the compressed data on a camera including an image sensing device used for the step of converting.

31. The method according to Claim 29 additionally comprising the step of deleting half of the third image data.

32. The method according to Claim 29, where the step of modifying comprises calculating an average of at least two pixels of third image data in subtracting the average from a pixel of the first image data that is adjacent to both of the at least two pixels of third image data.

33. The method according to Claim 32, where the step of calculating comprises calculating an average of at least four pixels of third image data.

34. The method according to Claim 29, wherein the third image data represents green image data.

35. The method according to Claim 29 additionally comprising decompressing the third image data and the modified first and second image data.

36. The method according to Claim 35 additionally comprising demosaicing the third image data.

37. The method according to Claim 36 additionally comprising demosaicing the first image data based on the demosaiced third image data.

38. The method according to Claim 36 additionally comprising demosaicing the first image data, then modifying the demosaiced first image data based on the demosaiced third image data.

39. The method according to Claim 29, wherein the step of modifying comprises calculating a value based on the third image data, subtracting the value from a value of the first image data, and wherein the method further comprises decompressing the third image data and the first and second modified image data, demosaicing the third image data, then demosaicing the first image data, then modifying the demosaiced first image data based on a value of the demosaiced third image data.

40. A video camera comprising:
a lens assembly supported by the housing and configured to focus light;
a light sensitive device configured to convert the focused light into a signal of raw image data representing the focused light;
a memory device; and
means for compressing and recording the raw image data at a frame rate of at least about 23 frames per second.

41. The video camera according to Claim 40, additionally comprising means for reducing an entropy of the raw image data before the means for compressing compresses the raw image data.

42. A video camera comprising:

WO 2008/128112

PCT/US2008/060126

a portable housing having at least one handle configured to allow a user to manipulate the orientation with respect to at least one degree of movement of the housing during a video recording operation of the camera;

a lens assembly comprising at least one lens supported by the housing and configured to focus light at a plane disposed inside the housing;

a light sensitive device configured to convert the focused light into raw image data with a horizontal resolution of at least 2k and at a frame rate of at least about twenty three frames per second;

a memory device configured to store video image data;

an image processing system configured to compress and store in the memory device the raw image data at a compression ratio of at least six to one and remain substantially visually lossless, and at a rate of at least about 23 frames per second.

43. The video camera according to Claim 42, wherein the image processing system is configured to reduce an entropy of the raw image data before compressing the raw image data.

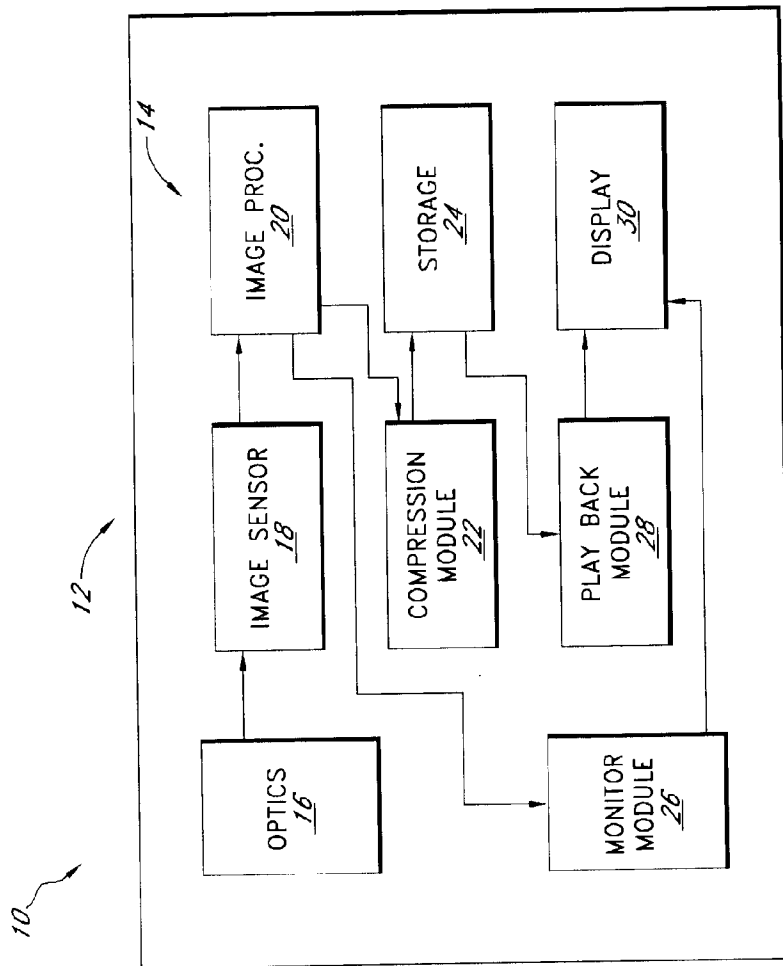

FIG. 1

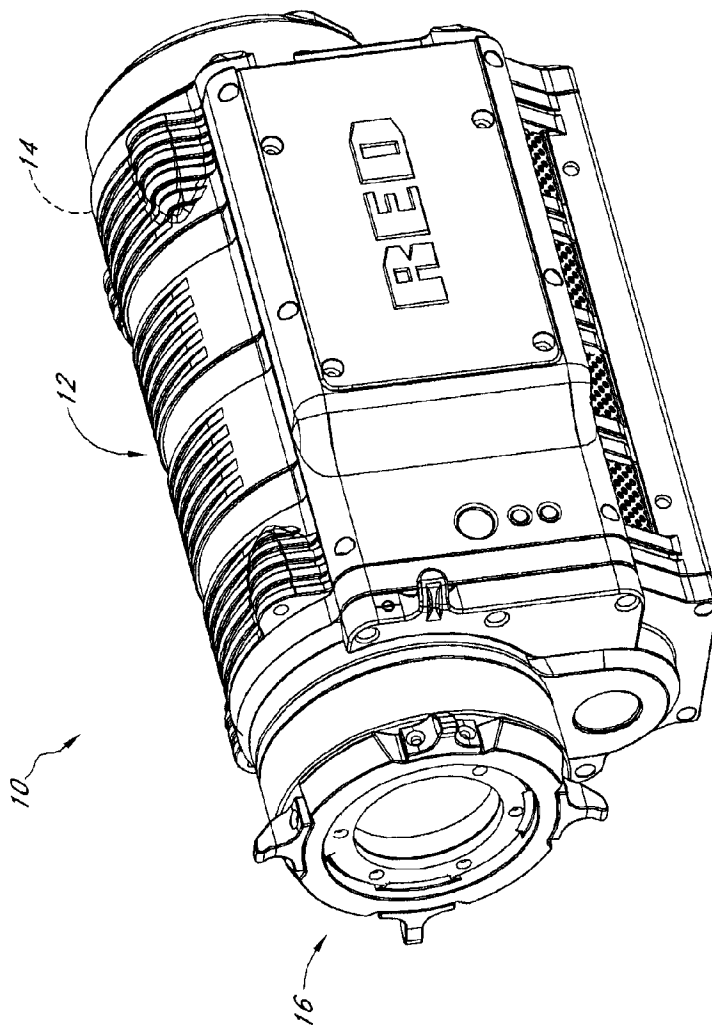

FIG. 2

	$m-3$	$m-2$	$m-1$	m	$m+1$	$m+2$	$m+3$	$m+4$
$n-3$	$B_{m-3,n-3}$	$C_{m-2,n-3}$	$B_{m-1,n-3}$	$C_{m,n-3}$	$B_{m+1,n-3}$	$C_{m+2,n-3}$	$B_{m+3,n-3}$	$C_{m+4,n-3}$
$n-2$	$C_{m-3,n-2}$	$R_{m-2,n-2}$	$C_{m-1,n-2}$	$R_{m,n-2}$	$C_{m+1,n-2}$	$R_{m+2,n-2}$	$C_{m+3,n-2}$	$R_{m+4,n-2}$
$n-1$	$B_{m-3,n-1}$	$C_{m-2,n-1}$	$B_{m-1,n-1}$	$C_{m,n-1}$	$B_{m+1,n-1}$	$C_{m+2,n-1}$	$B_{m+3,n-1}$	$C_{m+4,n-1}$
n	$C_{m-3,n}$	$R_{m-2,n}$	$C_{m-1,n}$	$R_{m,n}$	$C_{m+1,n}$	$R_{m+2,n}$	$C_{m+3,n}$	$R_{m+4,n}$
$n+1$	$B_{m-3,n+1}$	$C_{m-2,n+1}$	$B_{m-1,n+1}$	$C_{m,n+1}$	$B_{m+1,n+1}$	$C_{m+2,n+1}$	$B_{m+3,n+1}$	$C_{m+4,n+1}$
$n+2$	$C_{m-3,n+2}$	$R_{m-2,n+2}$	$C_{m-1,n+2}$	$R_{m,n+2}$	$C_{m+1,n+2}$	$R_{m+2,n+2}$	$C_{m+3,n+2}$	$R_{m+4,n+2}$
$n+3$	$B_{m-3,n+3}$	$C_{m-2,n+3}$	$B_{m-1,n+3}$	$C_{m,n+3}$	$B_{m+1,n+3}$	$C_{m+2,n+3}$	$B_{m+3,n+3}$	$C_{m+4,n+3}$
$n+4$	$C_{m-3,n+4}$	$R_{m-2,n+4}$	$C_{m-1,n+4}$	$R_{m,n+4}$	$C_{m+1,n+4}$	$R_{m+2,n+4}$	$C_{m+3,n+4}$	$R_{m+4,n+4}$

FIG. 3

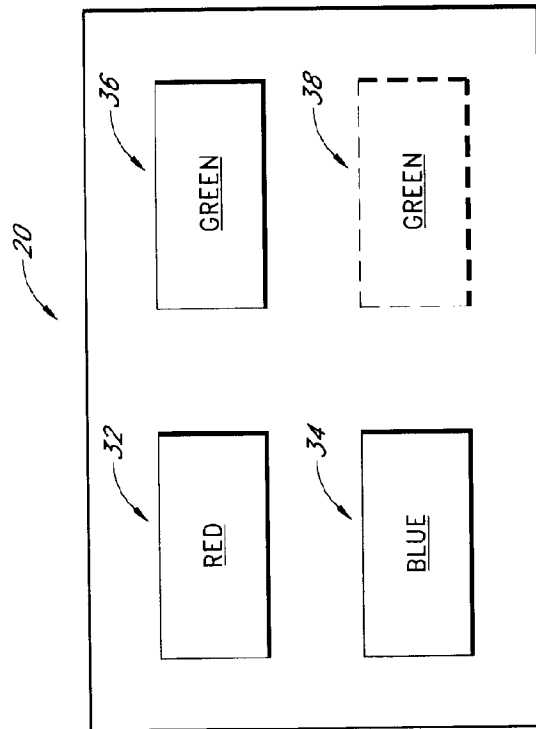

FIG. 4

$n-3$	$m-3$	$m-2$	$m-1$	m	$m+1$	$m+2$	$m+3$	$m+4$
	$G_{m-2,n-3}$			$G_{m,n-3}$		$G_{m+2,n-3}$		$G_{m+4,n-3}$
$n-2$	$G_{m-3,n-2}$		$G_{m-1,n-2}$		$G_{m+1,n-2}$		$G_{m+3,n-2}$	
$n-1$		$G_{m-2,n-1}$		$G_{m,n-1}$		$G_{m+2,n-1}$		$G_{m+4,n-1}$
n	$G_{m-3,n}$		$G_{m-1,n}$		$G_{m+1,n}$		$G_{m+3,n}$	
$n+1$		$G_{m-2,n+1}$		$G_{m,n+1}$		$G_{m+2,n+1}$		$G_{m+4,n+1}$
$n+2$	$G_{m-3,n+2}$		$G_{m-1,n+2}$		$G_{m+1,n+2}$		$G_{m+3,n+2}$	
$n+3$		$G_{m-2,n+3}$		$G_{m,n+3}$		$G_{m+2,n+3}$		$G_{m+4,n+3}$
$n+4$	$G_{m-3,n+4}$		$G_{m-1,n+4}$		$G_{m+1,n+4}$		$G_{m+3,n+4}$	

FIG. 5

	$m+4$							
	$m+3$		$G_{m+3,n-2}$		$G_{m+3,n}$		$G_{m+3,n+2}$	
	$m+2$							
	$m+1$		$G_{m+1,n-2}$		$G_{m+1,n}$		$G_{m+1,n+2}$	$G_{m+1,n+4}$
	m							
	$m-1$		$G_{m-1,n-2}$		$G_{m-1,n}$		$G_{m-1,n+2}$	$G_{m-1,n+4}$
	$m-2$							
$n-3$	$m-3$	$G_{m-3,n-2}$		$G_{m-3,n}$		$G_{m-3,n+2}$		$G_{m-3,n+4}$
$n-2$								
$n-1$								
n								
$n+1$								
$n+2$								
$n+3$								
$n+4$								

FIG. 6

$G_{m-3,n-2}$	$G_{m-1,n-2}$	$G_{m+1,n-2}$	$G_{m-3,n}$
$G_{m-3,n}$	$G_{m-1,n}$	$G_{m+1,n}$	$G_{m+3,n}$
$G_{m-3,n+2}$	$G_{m-1,n+2}$	$G_{m+1,n+2}$	$G_{m-3,n+4}$
$G_{m-3,n+4}$	$G_{m-1,n+4}$	$G_{m+1,n+4}$	$G_{m-3,n+6}$

GREEN 2

$R_{m-4,n-2}$	$R_{m,n-2}$	$R_{m+2,n-2}$	$R_{m+4,n-2}$
$R_{m-2,n}$	$R_{m,n}$	$R_{m+2,n}$	$R_{m+4,n}$
$R_{m-2,n+2}$	$R_{m,n+2}$	$R_{m+2,n+2}$	$R_{m+4,n+2}$
$R_{m-2,n+4}$	$R_{m,n+4}$	$R_{m+2,n+4}$	$R_{m+4,n+4}$

RED

$G_{m-2,n-3}$	$G_{m,n-3}$	$G_{m+2,n-3}$	$G_{m+4,n-3}$
$G_{m-2,n-1}$	$G_{m,n-1}$	$G_{m+2,n-1}$	$G_{m+4,n-1}$
$G_{m-2,n+1}$	$G_{m,n+1}$	$G_{m+2,n+1}$	$G_{m+4,n+1}$
$G_{m-2,n+3}$	$G_{m,n+3}$	$G_{m+2,n+3}$	$G_{m+4,n+3}$

GREEN 1

$B_{m-3,n-3}$	$B_{m-1,n-3}$	$B_{m+1,n-3}$	$B_{m+3,n-3}$
$B_{m-3,n-1}$	$B_{m-1,n-1}$	$B_{m+1,n-1}$	$B_{m+3,n-1}$
$B_{m-3,n+1}$	$B_{m-1,n+1}$	$B_{m+1,n+1}$	$B_{m+3,n+1}$
$B_{m-3,n+3}$	$B_{m-1,n+3}$	$B_{m+1,n+3}$	$B_{m+3,n+3}$

BLUE

FIG. 7

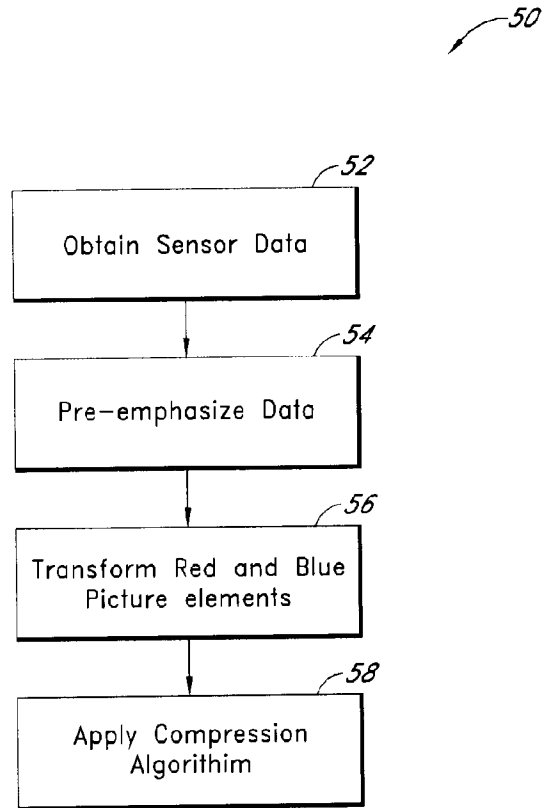

FIG. 8

9/18

50'

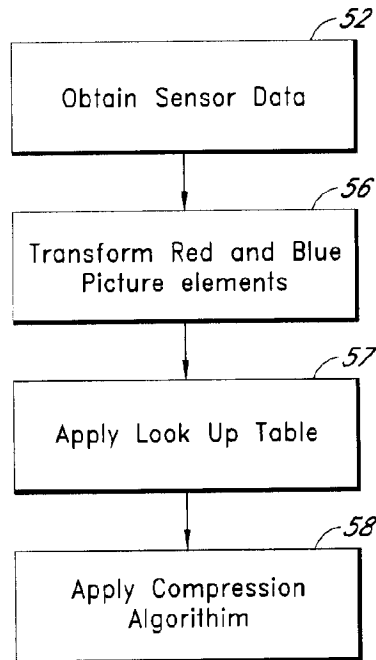

FIG. 8A

	$B_{m-1, n}^{n-1} = \frac{B_{m-1, n-1}^{n-1} + (G_{m-1, n-2} + G_{m, n-1} + G_{m-1, n} + G_{m-2, n-1})/4}{4}$		

FIG. 9

	$R_{m-2, n-2}^1 = \frac{R_{m-2, n-2} + (G_{m-2, n-3} + G_{m-1, n-2} + G_{m-2, n-1} + G_{m-3, n-2})/4}{4}$		

FIG. 10

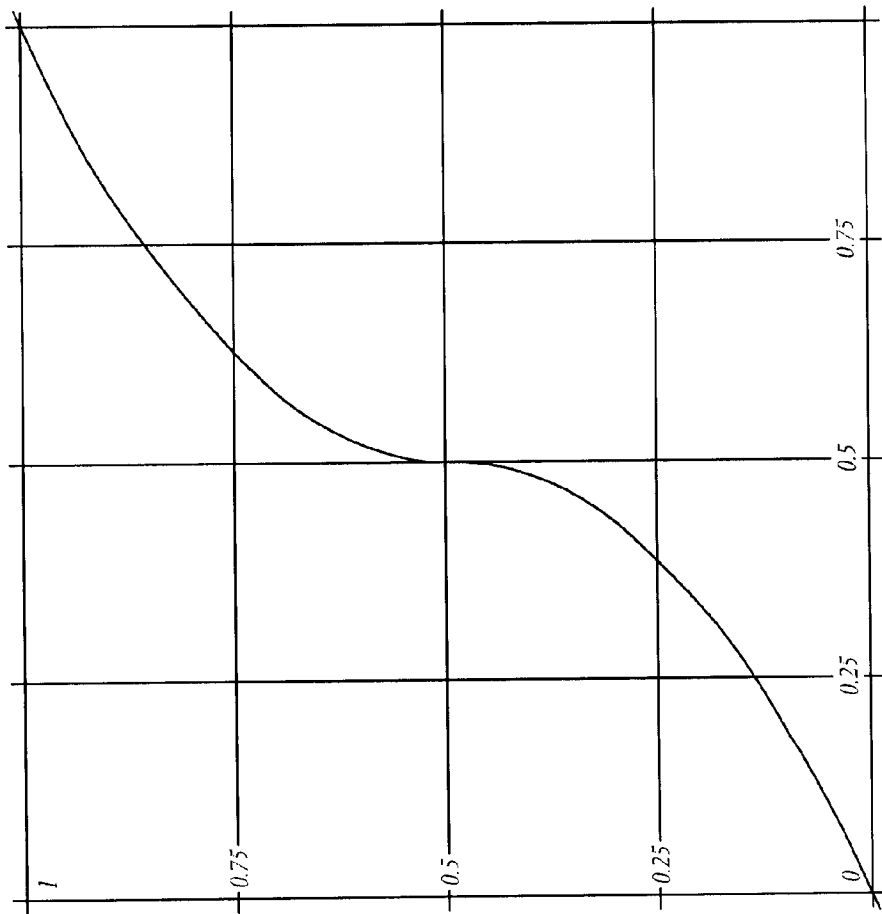

FIG. 11

13/18

60

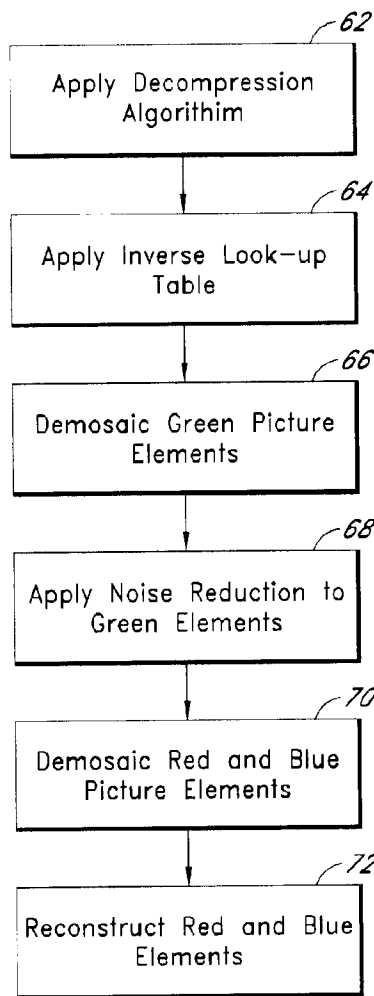

FIG. 12

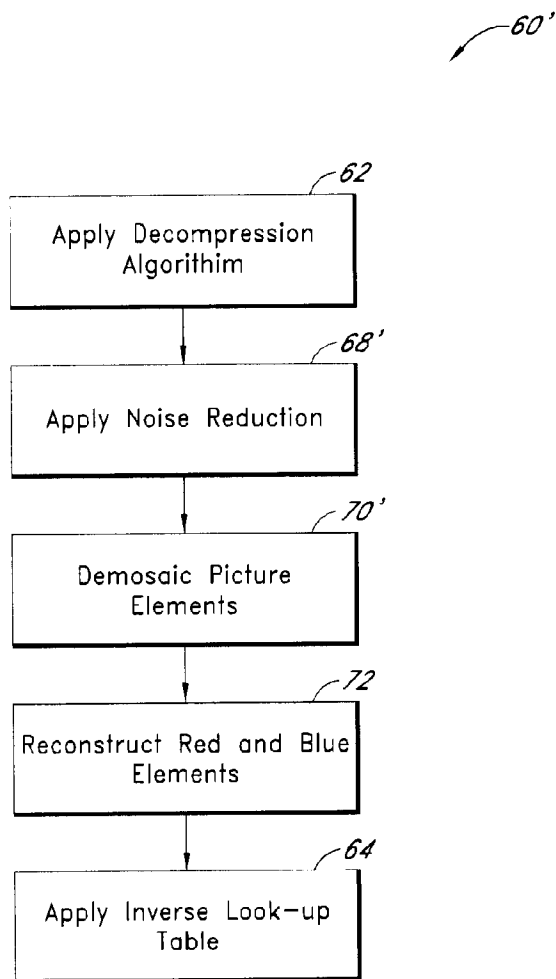

FIG. 12A

	$m-3$	$m-2$	$m-1$	m	$m+1$	$m+2$	$m+3$	$m+4$
$n-3$	$DC_{m-3,n-3}$	$G_{m-2,n-3}$	$DC_{m-1,n-3}$	$G_{m,n-3}$	$DC_{m+1,n-3}$	$G_{m+2,n-3}$	$DC_{m+3,n-3}$	$G_{m+4,n-3}$
$n-2$	$G_{m-3,n-2}$	$DC_{m-2,n-2}$	$G_{m-1,n-2}$	$DC_{m,n-2}$	$G_{m+1,n-2}$	$DC_{m+2,n-2}$	$G_{m+3,n-2}$	$DC_{m+4,n-2}$
$n-1$	$DC_{m-3,n-1}$	$G_{m-2,n-1}$	$DC_{m-1,n-1}$	$G_{m,n-1}$	$DC_{m+1,n-1}$	$G_{m+2,n-1}$	$DC_{m+3,n-1}$	$G_{m+4,n-1}$
n	$G_{m-3,n}$	$DC_{m-2,n}$	$G_{m-1,n}$	$DC_{m,n}$	$G_{m+1,n}$	$DC_{m+2,n}$	$G_{m+3,n}$	$DC_{m+4,n}$
$n+1$	$DC_{m-3,n+1}$	$G_{m-2,n+1}$	$DC_{m-1,n+1}$	$G_{m,n+1}$	$DC_{m+1,n+1}$	$G_{m+2,n+1}$	$DC_{m+3,n+1}$	$G_{m+4,n+1}$
$n+2$	$G_{m-3,n+2}$	$DC_{m-2,n+2}$	$G_{m-1,n+2}$	$DC_{m,n+2}$	$G_{m+1,n+2}$	$DC_{m+2,n+2}$	$G_{m+3,n+2}$	$DC_{m+4,n+2}$
$n+3$	$DC_{m-3,n+3}$	$G_{m-2,n+3}$	$DC_{m-1,n+3}$	$G_{m,n+3}$	$DC_{m+1,n+3}$	$G_{m+2,n+3}$	$DC_{m+3,n+3}$	$G_{m+4,n+3}$
$n+4$	$G_{m-3,n+4}$	$DC_{m-2,n+4}$	$G_{m-1,n+4}$	$DC_{m,n+4}$	$G_{m+1,n+4}$	$DC_{m+2,n+4}$	$G_{m+3,n+4}$	$DC_{m+4,n+4}$

FIG. 13

	$n-3$	$n-2$	$n-1$	m	$m+1$	$m+2$	$m+3$	$m+4$
$n-3$	$DC_{m-3,n-3}$	$DC_{m-2,n-2}$	$DC_{m-1,n-1}$	$DC_{m,n}$	$DC_{m+1,n+1}$	$DC_{m+2,n+2}$	$DC_{m+3,n+3}$	$DC_{m+4,n+4}$
$n-2$	$G_{m-3,n-2}$	$DC_{m-2,n-2}$	$G_{m-1,n-1}$	$DC_{m,n}$	$G_{m+1,n+1}$	$DC_{m+2,n+2}$	$G_{m+3,n+3}$	$DC_{m+4,n+4}$
$n-1$	$DC_{m-3,n-1}$	$DC_{m-2,n-1}$	$DC_{m-1,n-1}$	$DC_{m,n-1}$	$DC_{m+1,n}$	$DC_{m+2,n+1}$	$DC_{m+3,n+2}$	$DC_{m+4,n+3}$
n	$G_{m-3,n}$	$DC_{m-2,n}$	$G_{m-1,n}$	$DC_{m,n}$	$G_{m+1,n}$	$DC_{m+2,n}$	$G_{m+3,n}$	$DC_{m+4,n}$
$n+1$	$DC_{m-3,n+1}$	$DC_{m-2,n+1}$	$DC_{m-1,n+1}$	$DC_{m,n+1}$	$DC_{m+1,n+1}$	$DC_{m+2,n+1}$	$DC_{m+3,n+1}$	$DC_{m+4,n+1}$
$n+2$	$G_{m-3,n+2}$	$DC_{m-2,n+2}$	$G_{m-1,n+2}$	$DC_{m,n+2}$	$G_{m+1,n+2}$	$DC_{m+2,n+2}$	$G_{m+3,n+2}$	$DC_{m+4,n+2}$
$n+3$	$DC_{m-3,n+3}$	$DC_{m-2,n+3}$	$DC_{m-1,n+3}$	$DC_{m,n+3}$	$DC_{m+1,n+3}$	$DC_{m+2,n+3}$	$DC_{m+3,n+3}$	$DC_{m+4,n+3}$
$n+4$	$G_{m-3,n+4}$	$DC_{m-2,n+4}$	$G_{m-1,n+4}$	$DC_{m,n+4}$	$G_{m+1,n+4}$	$DC_{m+2,n+4}$	$G_{m+3,n+4}$	$DC_{m+4,n+4}$

FIG. 14

	$m-3$	$m-2$	$m-1$	m	$m+1$	$m+2$	$m+3$	$m+4$
$n-3$	$B_{m-3,n-3}$		$B_{m-1,n-3}$		$B_{m+1,n-3}$		$B_{m+3,n-3}$	
$n-2$								
$n-1$	$B_{m-3,n-4}$		$B_{m-1,n-1}$		$B_{m+1,n-1}$		$B_{m+3,n-1}$	
n								
$n+1$	$B_{m-3,n+1}$		$B_{m-1,n+1}$		$B_{m+1,n+1}$		$B_{m+3,n+1}$	
$n+2$								
$n+3$	$B_{m-3,n+3}$		$B_{m-1,n+3}$		$B_{m+1,n+3}$		$B_{m+3,n+3}$	
$n+4$								

FIG. 15

	$m-3$	$m-2$	$m-1$	m	$m+1$	$m+2$	$m+3$	$m+4$
$n-3$	$B_{m-3,n-3}$	$DB_{m-2,n-3}$	$B_{m-1,n-3}$	$DB_{m,n-3}$	$B_{m+1,n-3}$	$DB_{m+2,n-3}$	$B_{m+3,n-3}$	$DB_{m+4,n-3}$
$n-2$	$DB_{m-3,n-2}$	$DB_{m-2,n-2}$	$DB_{m-1,n-2}$	$DB_{m,n-2}$	$DB_{m+1,n-2}$	$DB_{m+2,n-2}$	$DB_{m+3,n-2}$	$DB_{m+4,n-2}$
$n-1$	$B_{m-3,n-1}$	$DB_{m-2,n-1}$	$B_{m-1,n-1}$	$DB_{m,n-1}$	$B_{m+1,n-1}$	$DB_{m+2,n-1}$	$B_{m+3,n-1}$	$DB_{m+4,n-1}$
n	$DB_{m-3,n}$	$DB_{m-2,n}$	$DB_{m-1,n}$	$DB_{m,n}$	$DB_{m+1,n}$	$DB_{m+2,n}$	$DB_{m+3,n}$	$DB_{m+4,n}$
$n+1$	$B_{m-3,n+1}$	$DB_{m-2,n+1}$	$B_{m-1,n+1}$	$DB_{m,n+1}$	$B_{m+1,n+1}$	$DB_{m+2,n+1}$	$B_{m+3,n+1}$	$DB_{m+4,n+1}$
$n+2$	$DB_{m-3,n+2}$	$DB_{m-2,n+2}$	$DB_{m-1,n+2}$	$DB_{m,n+2}$	$DB_{m+1,n+2}$	$DB_{m+2,n+2}$	$DB_{m+3,n+2}$	$DB_{m+4,n+2}$
$n+3$	$B_{m-3,n+3}$	$DB_{m-2,n+3}$	$B_{m-1,n+3}$	$DB_{m,n+3}$	$B_{m+1,n+3}$	$DB_{m+2,n+3}$	$B_{m+3,n+3}$	$DB_{m+4,n+3}$
$n+4$	$DB_{m-3,n+4}$	$DB_{m-2,n+4}$	$DB_{m-1,n+4}$	$DB_{m,n+4}$	$DB_{m+1,n+4}$	$DB_{m+2,n+4}$	$DB_{m+3,n+4}$	$DB_{m+4,n+4}$

FIG. 16

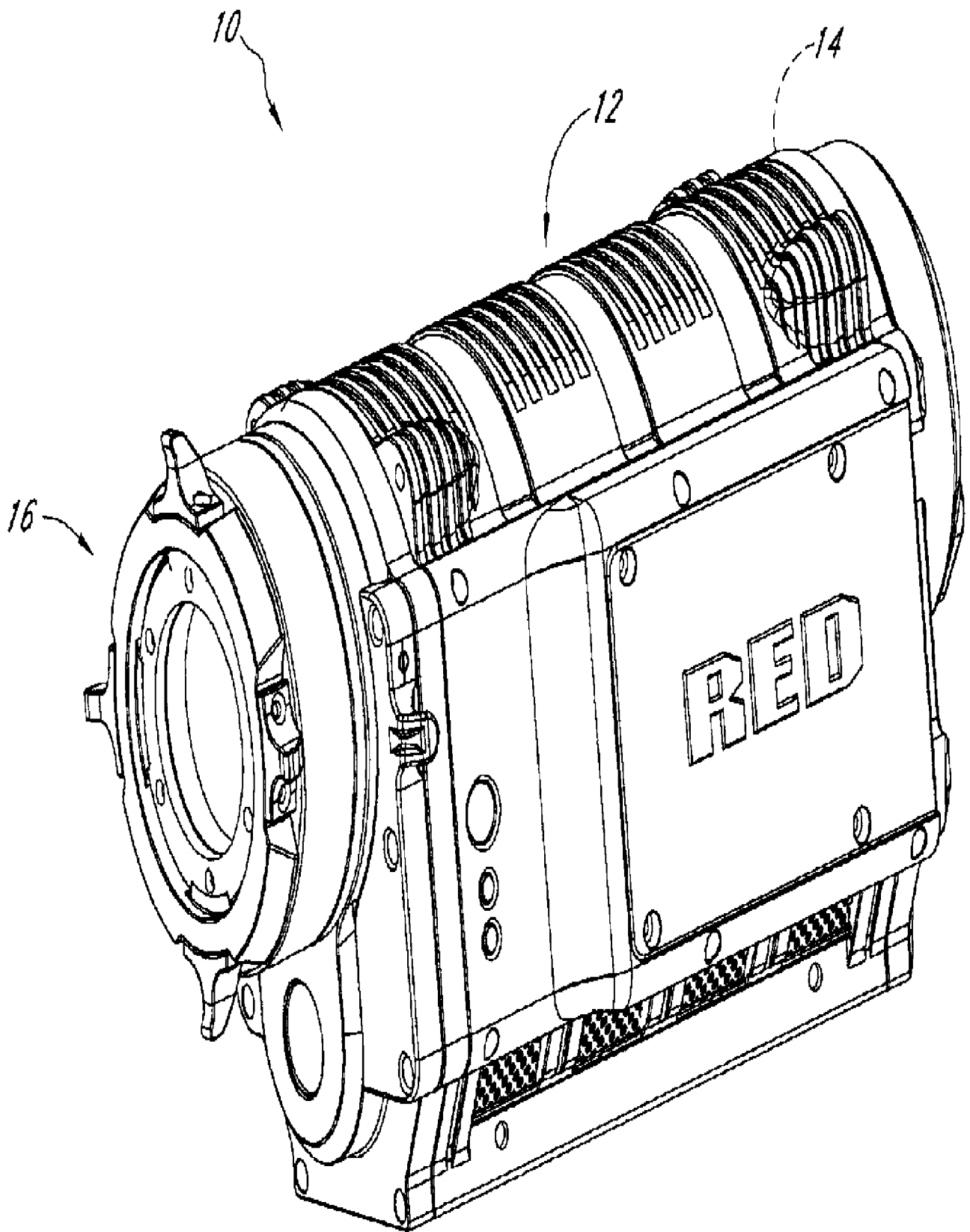

PATENT ABSTRACTS OF JAPAN

(11)Publication number : **2008-124976**

(43)Date of publication of application : **29.05.2008**

(51)Int.Cl.	<i>H04N</i>	<i>5/335</i>	<i>(2006.01)</i>
	<i>G06T</i>	<i>5/00</i>	<i>(2006.01)</i>
	<i>H04N</i>	<i>1/409</i>	<i>(2006.01)</i>
	<i>G06T</i>	<i>5/20</i>	<i>(2006.01)</i>

(21)Application number : 2006-308997	(71)Applicant : FUJITSU LTD
(22)Date of filing : 15.11.2006	(72)Inventor : WATARAI YUJI

(54) IMAGE PROCESSING APPARATUS AND IMAGE PROCESSING METHOD

(57)Abstract:

PROBLEM TO BE SOLVED: To provide an image processing apparatus and image processing method in which noise reduction effect can be exerted in accordance with a pixel value of a target pixel.

SOLUTION: An image processing apparatus 10A reduces noise contained in a target pixel while reflecting peripheral pixels around the target pixel and comprises a selection unit 12 which selects a pixel width allowable for a true value as a pixel value of the target pixel in accordance with the true value of the target pixel, and correction units 13A-13Y each for extracting either or both pixel values of the peripheral pixels and the pixel value of the target pixel as a correction value for correcting the pixel value of the target pixel in accordance with the pixel width selected by the selection unit 12.

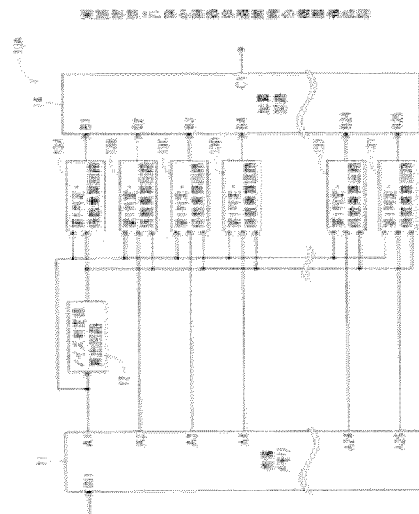

* NOTICES *

JPO and INPIT are not responsible for any damages caused by the use of this translation.

- 1.This document has been translated by computer. So the translation may not reflect the original precisely.
- 2.**** shows the word which can not be translated.
- 3.In the drawings, any words are not translated.

CLAIMS

[Claim(s)]

[Claim 1]

In an image processing system which reduces a noise contained in the aforementioned noticed picture element while making a peripheral pixel which is placed at the circumference of a noticed picture element reflect,

A selection part which selects pixel width permitted to the aforementioned true value as a pixel value of the aforementioned noticed picture element according to a true value of the aforementioned noticed picture element,

A correction part which extracts inner either or both sides of a pixel value of the aforementioned peripheral pixel, and a pixel value of the aforementioned noticed picture element as correction value which corrects a pixel value of the aforementioned noticed picture element according to the aforementioned pixel width selected by the aforementioned selection part,

An image processing system characterized by preparation *****.

[Claim 2]

In an image processing system which reduces a noise contained in the aforementioned noticed picture element while making a peripheral pixel which is placed at the circumference of a noticed picture element reflect,

A selection part which selects pixel width permitted to the aforementioned true value as a pixel value of the aforementioned noticed picture element according to a true value of the aforementioned noticed picture element,

epsilon filter which made the aforementioned pixel width selected by the aforementioned selection part reference value in comparison with a difference value of a pixel value of the aforementioned peripheral pixel, and a pixel value of the aforementioned noticed picture element,

An image processing system characterized by preparation *****.

[Claim 3]

The image processing system according to claim 1 or 2, wherein the aforementioned selection part defines the aforementioned pixel width based on standard deviation in distribution of a pixel value of the aforementioned noticed picture element.

[Claim 4]

The aforementioned correction part the aforementioned pixel width based on a comparison result in comparison with a difference value of a pixel value of the aforementioned peripheral pixel, and a pixel value of the aforementioned noticed picture element as the aforementioned correction value, The image processing system according to claim 1 extracting inner either or both sides of

a pixel value of the aforementioned peripheral pixel, and a pixel value of the aforementioned noticed picture element.

[Claim 5]

Based on the aforementioned comparison result, on condition that it judged that the aforementioned difference value was below the aforementioned pixel width, the aforementioned correction part, The image processing system according to claim 4 extracting a pixel value of the aforementioned peripheral pixel as the aforementioned correction value, and extracting a pixel value of the aforementioned noticed picture element as the aforementioned correction value based on the aforementioned comparison result on condition that it judged that the aforementioned difference value was larger than the aforementioned pixel width.

[Claim 6]

The aforementioned correction part the aforementioned pixel width based on a comparison result in comparison with a difference value of a median value of all the pixel values of a pixel value of the aforementioned peripheral pixel, and a pixel value of the aforementioned noticed picture element, and a pixel value of the aforementioned noticed picture element as the aforementioned correction value, The image processing system according to claim 1 extracting the aforementioned median value or a pixel value of the aforementioned noticed picture element.

[Claim 7]

Based on the aforementioned comparison result, on condition that it judged that the aforementioned difference value was below the aforementioned pixel width, the aforementioned correction part, The image processing system according to claim 6 extracting the aforementioned median value as the aforementioned correction value, and extracting a pixel value of the aforementioned noticed picture element as the aforementioned correction value based on the aforementioned comparison result on condition that it judged that the aforementioned difference value was larger than the aforementioned pixel width.

[Claim 8]

In an image processing method used for an image processing system which reduces a noise contained in the aforementioned noticed picture element while making a peripheral pixel which is placed at the circumference of a noticed picture element reflect,

A selection step which selects pixel width permitted to the aforementioned true value as a pixel value of the aforementioned noticed picture element according to a true value of the aforementioned noticed picture element,

A correction step which extracts inner either or both sides of a pixel value of the aforementioned peripheral pixel, and a pixel value of the aforementioned noticed picture element as correction value which corrects a pixel value of the aforementioned noticed picture element according to the aforementioned pixel width selected by the aforementioned selection step,

An image processing method characterized by preparation *****.

[Claim 9]

In an image processing method used for an image processing system which reduces a noise contained in the aforementioned noticed picture element while making a peripheral pixel which is placed at the circumference of a noticed picture element reflect,

A selection step which selects pixel width permitted to the aforementioned true value as a pixel value of the aforementioned noticed picture element according to a true value of the aforementioned noticed picture element,

A comparison step [a difference value of a pixel value of the aforementioned peripheral pixel, and a pixel value of the aforementioned noticed picture element / width / aforementioned / which

was selected by the aforementioned selection step / pixel],
An image processing method characterized by preparation *****.

[Claim 10]

The image processing method according to claim 8 or 9, wherein the aforementioned selection step defines the aforementioned pixel width based on standard deviation in distribution of a pixel value of the aforementioned noticed picture element.

DETAILED DESCRIPTION

[Detailed Description of the Invention]

[Field of the Invention]

[0001]

This invention relates to an image processing system and an image processing method.

[Background of the Invention]

[0002]

For example, a digital camera converts the image photoed with the image sensor to a digital image. In the digital camera in recent years, since the photodetection capability of an image sensor is improving, in addition to the light from an object, it becomes easy to detect random noise etc. and the S/N ratio is deteriorated. Then, in the digital camera in recent years, making it not make the image quality of the photoed image be deteriorated, random noise etc. are reduced and making a S/N ratio improve is searched for.

[0003]

Generally, random noise etc. are reduced and the thing using a spatial filter and a median filter provided with the weight table is known as an image processing system which makes a S/N ratio improve, respectively. For example, the above-mentioned spatial filter continues throughout a digital image, performs sequentially product sum operation of the pixel value of 3x3 regions in a digital image, and the weight table of 3x3 regions, and is computing sequentially the average value as a result of each product sum operation as it discloses in the nonpatent literature 1. And in the above-mentioned spatial filter, each computed average value is made into the pixel value of the noticed picture element of 3x3 regions, and a digital image is corrected by each average value computed by having continued throughout the digital image. Then, in the above-mentioned spatial filter, since a digital image is corrected by each average value, the random noise mixed in the digital image before correction is smoothed. For this reason, in the above-mentioned spatial filter, the random noise mixed in the digital image before correction is reduced, and a S/N ratio can be improved.

[0004]

In [as it discloses in the nonpatent literature 2 for example,] the above-mentioned median filter, The median value (mean value) of the values which arranged all the picture values of 3x3 regions in a digital image in an order from what has a large value, changed them, and were put in order and changed as a pixel value of the noticed picture element of 3x3 regions is calculated. And in this median filter, it continues throughout a digital image, a median value is calculated, and a digital image is corrected by each median value. Then, in this median filter, since a digital image is corrected by each median value, the noise mixed in the digital image by the maximum of the values put in order and changed compared with the case where a digital image is formed is stopped. For this reason, in this median filter, a S/N ratio is improvable by correcting a digital image with a median value.

[0005]

The thing which makes a S/N ratio improve using epsilon filter as an image processing system is known (see nonpatent literature 3.). epsilon filter has the characteristic which removes the small-size width random noise added to the signal, maintaining the sudden large amplitude variable component in a signal. Then, in epsilon filter, for example, the random noise added to the signal of the light from an object can be removed, and a S/N ratio can be improved.

[Nonpatent literature 1] Akira TANAKA, Hiroshi, a "image processing applied technology", the 3rd edition, Kogyo Chosakai Publishing Co., Ltd., June, 1991, p.57-58

[Nonpatent literature 2] Your family Akira Nishi, "the digital image technology known well", the first edition, CQ publication incorporated company, February, 1996, p.102

[Nonpatent literature 3] Harashima Hiroshi, outside trinomial "epsilon-separation nonlinear digital filter and its application", 1982, IEICE TRANSACTIONS, vol.J65-A, no.4, p297-304

[Description of the Invention]

[Problem to be solved by the invention]

[0006]

However, in the image processing system using the spatial filter mentioned above, when computing the pixel value of a noticed picture element, the pixel value which the noise mixed excessively is used and there is a possibility that the average value of product sum operation may be computed. Also in the image processing system using the median filter mentioned above, when calculating the pixel value of a noticed picture element, the pixel value which the noise mixed excessively is used and there is a possibility that a median value may be calculated. In such a case, in response to the influence of the pixel value which the noise mixed excessively, a pixel value is prevented from approaching the true value of a noticed picture element of a noticed picture element. Then, in the image processing system mentioned above, the reduction effect of a noise is not sufficient and there is a possibility that a digital image may become indistinct.

[0007]

Distribution of the noise mixed in a digital image shows the normal distribution from which the existence probability to the true value of a noticed picture element serves as the maximum so that it may illustrate to Fig.10. The standard deviation σ of a noise increases as the pixel value of a noticed picture element enlarges so that it may illustrate to Fig.11.

[0008]

However, in the image processing system using epsilon filter mentioned above, it was not taken into consideration that the standard deviation σ of a noise changes with the pixel values of a noticed picture element, but the noise decision value was set as the fixed value, and random noise was removed. So, in the region where the pixel value of a noticed picture element is small, it will be set to the value whose threshold value defined with a noise decision value compared with the region where a pixel value is large is higher than the optimal value. For this reason, in addition to a noise, there is a possibility that the concentration of an excessive next door and a digital image of correction of a digital image may be deteriorated.

[0009]

In addition, in the region where the pixel value of a noticed picture element is large, it will be set to the value whose threshold value defined with a noise decision value compared with the region where a pixel value is small is lower than the optimal value. For this reason, a noise could not be removed sufficiently but there was a possibility that a digital image might become indistinct.

[0010]

An object of this invention is to provide the image processing system and image processing method which can be proposed in view of such a situation, can make it able to respond to the pixel value of a noticed picture element, and can demonstrate the mitigation effect of a noise.

[Means for solving problem]

[0011]

In the image processing system which reduces the noise contained in the aforementioned noticed picture element while the image processing system concerning invention of Claim 1 makes the

peripheral pixel which is placed at the circumference of a noticed picture element reflect, The selection part which selects the pixel width permitted to the aforementioned true value as a pixel value of the aforementioned noticed picture element according to the true value of the aforementioned noticed picture element, According to the aforementioned pixel width selected by the aforementioned selection part, it has a correction part which extracts inner either or both sides of the pixel value of the aforementioned peripheral pixel, and the pixel value of the aforementioned noticed picture element as correction value which corrects the pixel value of the aforementioned noticed picture element.

[0012]

According to the image processing system concerning invention of Claim 1, if a selection part selects the pixel width permitted to a true value as a pixel value of a noticed picture element according to the true value of a noticed picture element, it can change the pixel width selected according to the true value of a noticed picture element.

According to invention of Claim 1, according to the pixel width selected by the selection part, a correction part extracts inner either or both sides of the pixel value of a peripheral pixel, and the pixel value of a noticed picture element as correction value which corrects the pixel value of a noticed picture element. Then, the correction part can change the correction value extracted according to pixel width. Therefore, according to the image processing system concerning invention of Claim 1, with the correction value extracted by the correction part, the pixel value of a noticed picture element can be corrected and the pixel value of this noticed picture element can be made into what reduced the noise.

[0013]

In the image processing method used for the image processing system which reduces the noise contained in the aforementioned noticed picture element while the image processing method concerning invention of Claim 8 makes the peripheral pixel which is placed at the circumference of a noticed picture element reflect, The selection step which selects the pixel width permitted to the aforementioned true value as a pixel value of the aforementioned noticed picture element according to the true value of the aforementioned noticed picture element, According to the aforementioned pixel width selected by the aforementioned selection step, it has a correction step which extracts inner either or both sides of the pixel value of the aforementioned peripheral pixel, and the pixel value of the aforementioned noticed picture element as correction value which corrects the pixel value of the aforementioned noticed picture element.

[0014]

If a selection step selects the pixel width permitted to a true value as a pixel value of a noticed picture element according to the true value of a noticed picture element according to the image processing method concerning invention of Claim 8, the pixel width selected can be changed according to the true value of a noticed picture element.

According to invention of Claim 8, according to the pixel width selected by the selection step, a correction step extracts inner either or both sides of the pixel value of a peripheral pixel, and the pixel value of a noticed picture element as correction value which corrects the pixel value of a noticed picture element. Then, the correction step can change the correction value extracted according to pixel width. Therefore, according to the image processing method concerning invention of Claim 8, with the correction value extracted by the correction step, the pixel value of a noticed picture element can be corrected and the pixel value of this noticed picture element can be made into what reduced the noise.

[Effect of the Invention]

[0015]

If the pixel width permitted to a true value as a pixel value of a noticed picture element is selected according to the true value of a noticed picture element according to the image processing system and image processing method of the present invention, the pixel width selected can be changed according to the true value of a noticed picture element.

According to the present invention, according to the selected pixel width, inner either or both sides of the pixel value of a peripheral pixel and the pixel value of a noticed picture element is extracted as correction value which corrects the pixel value of a noticed picture element. Then, the correction value extracted can be changed according to pixel width. Therefore, according to the present invention, with the extracted correction value, the pixel value of a noticed picture element can be corrected and the pixel value of this noticed picture element can be made into what reduced the noise.

[Best Mode of Carrying Out the Invention]

[0016]

<Embodiment 1>

Embodiment 1 of the present invention is described referring to Fig.1 thru/or Fig.4. Here, the image processing system 10A mounted on the digital camera in the image processing system of the present invention is mentioned as an example, and is described. Fig.1 is a block diagram showing the composition of the image processing system 10A of Embodiment 1. The image processing system 10A is provided with the following.

It is the image memory 11 so that it may illustrate.

Noise decision value calculation circuit 12.

The 1st judgment and the coefficient multiplication circuits 13A-13Y.

Adder circuit 14.

[0017]

The image memory 11 is constituted by SRAM and FF. Although not illustrated, the output of the signal conversion section which processes the signal of an image sensor is connected to input terminal IN1 of the image memory 11.

[0018]

The input terminal of the noise decision value calculation circuit 12 is connected to the noticed picture element value output terminal A1 of the image memory 11. The noise decision value calculation circuit 12 is constituted from Embodiment 1 by the lookup table memory.

[0019]

The 1st input terminal of the 1st judgment and the coefficient multiplication circuit 13A is connected to the noticed picture element value output terminal A1 of the image memory 11. The 2nd input terminal of the 1st judgment and the coefficient multiplication circuit 13A is connected to the output terminal of the noise decision value calculation circuit 12.

[0020]

The 1st input terminal of the 1st judgment and the coefficient multiplication circuit 13B is connected to the noticed picture element value output terminal A1 of the image memory 11. The 2nd input terminal of the 1st judgment and the coefficient multiplication circuit 13B is connected to the peripheral pixel value output terminal A2 of the image memory 11. The 3rd input terminal of the 1st judgment and the coefficient multiplication circuit 13B is connected to the output terminal of the noise decision value calculation circuit 12.

[0021]

Each 1st input terminal of the 1st judgment and the coefficient multiplication circuits 13C-13Y is connected to the noticed picture element value output terminal A1 of the image memory 11 as well as the 1st input terminal of the 1st judgment and the coefficient multiplication circuit 13B. Each 2nd input terminal of the 1st judgment and the coefficient multiplication circuits 13C-13Y is connected to each peripheral pixel value output terminal A3 of the image memory 11 - A25, respectively. Each 3rd input terminal of the 1st judgment and the coefficient multiplication circuits 13C-13Y is connected to the output terminal of the noise decision value calculation circuit 12.

[0022]

The input terminal B1 of the adder circuit 14 is connected to the output terminal of the 1st judgment and the coefficient multiplication circuit 13A. Each input terminal B-2 of the adder circuit 14 - B25 are connected to each output terminal of the 1st judgment and the coefficient multiplication circuits 13B-13Y, respectively. The code C1 in a figure is an output terminal of the adder circuit 14.

[0023]

Next, it describes about the image processing method of the image processing system 10A of Embodiment 1. As mentioned above, the output of the signal conversion section which processes the signal of an image sensor is connected to input terminal IN1 of the image memory 11. And a digital signal is input into the image memory 11 via the aforementioned input terminal IN1.

[0024]

The image memory 11 memorizes the line data of the brightness component generated by the signal conversion section which processes the signal of an image sensor. Line data are constituted by two or more pixel values. The image memory 11 memorizes the data of the digital image of an object for every line data.

[0025]

In the image processing system 10A of this embodiment, the image memory 11 extracts 5x5 every 5 pixels regions from the data of the digital image memorized by the image memory 11 to X-direction and Y-direction, respectively so that it may illustrate to Fig.2. P22 in a figure shows noticed picture element value data, and all the codes P00-P44 other than P22 show peripheral pixel value data. According to this embodiment, what deleted noise data from the noticed picture element value data P22 is equivalent to the true value of the noticed picture element of the present invention.

[0026]

In the image processing system 10A, the image memory 11 outputs the noticed picture element value data P22 to the noise decision value calculation circuit 12, and each 1st judgment and coefficient multiplication circuits 13A-13Y from the noticed picture element value output terminal A1. In addition, the image memory 11 is controlled by CPU and outputs the peripheral pixel value data P00 etc. to each 1st judgment and coefficient multiplication circuits 13B-13Y, respectively from each peripheral pixel value output terminal A2-A25.

[0027]

The noise decision value epsilon corresponding to the noticed picture element value data P22 outputted by the image memory 11 is memorized as a look-up table in the noise decision value calculation circuit 12. The noise decision value calculation circuit 12 outputs reading and this noise decision value epsilon for the noise decision value epsilon to each 1st judgment and coefficient multiplication circuits 13A-13Y from a look-up table according to the aforementioned noticed picture element value data P22. Here, the noise decision value epsilon is

set as 3σ . The noise decision value epsilon increases as the pixel value (P22) of a noticed picture element enlarges so that it may illustrate to [Fig.3](#). σ is the standard deviation of a noise.

[0028]

As mentioned above, the noticed picture element value data P22 and the data of the noise decision value epsilon are input into the 1st judgment and the coefficient multiplication circuit 13A. The data of the noise decision value epsilon of the noticed picture element value data P22, the peripheral pixel value data P00, etc. is input into each 1st judgment and coefficient multiplication circuits 13B-13Y, respectively.

[0029]

The 1st judgment and the coefficient multiplication circuit 13A subtract the pixel value (P22) of a noticed picture element from the pixel value (P22) of a noticed picture element first. Next, the 1st judgment and the coefficient multiplication circuit 13A compare the absolute value of a subtraction result with the noise decision value epsilon. The 1st judgment and the coefficient multiplication circuit 13A judge that the aforementioned absolute value is below the noise decision value epsilon, and chooses the pixel value of a noticed picture element.

[0030]

Then, the 1st judgment and the coefficient multiplication circuit 13A carry out the multiplication of the filter factor K22 (refer to [Fig.4](#).) to the pixel value of a noticed picture element to the pixel value of a noticed picture element. Then, the 1st judgment and the coefficient multiplication circuit 13A output the value of a multiplication result to the input terminal B1 of the adder circuit 14. The filter factor K22 corresponding to [so that the 1st judgment and the coefficient multiplication circuit 13A may be illustrated to [Fig.4](#)] the pixel value (P22) of a noticed picture element and the filter factor (K00-K44 except K22) corresponding to the pixel value (P00-P44 except P22) of a peripheral pixel, It has memorized as a filter table. In this embodiment, each filter factor is set as $1/25$, and the weighting of each filter factor is the same.

[0031]

The 1st judgment and the coefficient multiplication circuit 13B subtract the pixel value (P22) of a noticed picture element from the pixel value (P00) of a peripheral pixel first. Next, the 1st judgment and the coefficient multiplication circuit 13B compare the absolute value of a subtraction result with the aforementioned noise decision value epsilon. If the 1st judgment and the coefficient multiplication circuit 13B judge that the aforementioned absolute value is below the noise decision value epsilon, it will choose the pixel value (P00) of a peripheral pixel. The 1st judgment and the coefficient multiplication circuit 13B have judged that the pixel value (P00) of a peripheral pixel is a value permitted to the pixel value (P22) of a noticed picture element by judging that the aforementioned absolute value is below the noise decision value epsilon. Therefore, the noise decision value epsilon means the pixel width permitted to the pixel value of a noticed picture element.

[0032]

Then, the 1st judgment and the coefficient multiplication circuit 13B carry out the multiplication of the filter factor K00 (refer to [Fig.4](#).) to the pixel value (P00) of a peripheral pixel to the pixel value (P00) of a peripheral pixel. Then, the 1st judgment and the coefficient multiplication circuit 13B output the value of a multiplication result to input terminal B-2 of the adder circuit 14.

[0033]

On the other hand, if the 1st judgment and the coefficient multiplication circuit 13B judge that

the aforementioned absolute value is greater than the noise decision value epsilon, it will choose the pixel value (P22) of a noticed picture element. Then, the 1st judgment and the coefficient multiplication circuit 13B carry out the multiplication of the filter factor K22 corresponding to the pixel value (P22) of a noticed picture element to the pixel value (P22) of a noticed picture element. Then, the 1st judgment and the coefficient multiplication circuit 13B output the value of a multiplication result to input terminal B-2 of the adder circuit 14.

[0034]

Each 1st judgment and coefficient multiplication circuits 13C-13Y subtract the pixel value (P22) of a noticed picture element from the pixel value (P10-P44 except P00 and P22) of a peripheral pixel, respectively like the 1st judgment and the coefficient multiplication circuit 13B mentioned above. Next, the 1st judgment and the coefficient multiplication circuits 13C-13Y compare the absolute value of the subtracted result with the aforementioned noise decision value epsilon, respectively. If each 1st judgment and coefficient multiplication circuits 13C-13Y judge that each absolute value is below the noise decision value epsilon, they will choose the pixel value (above P10-P44) of a peripheral pixel, respectively.

[0035]

Then, each 1st judgment and coefficient multiplication circuits 13C-13Y carry out the multiplication of the filter factors K10-K44 (refer to [Fig.4.](#)) corresponding to the pixel value (above P10-P44) of a peripheral pixel to the pixel value (above P10-P44) of a peripheral pixel, respectively. Then, each 1st judgment and coefficient multiplication circuits 13C-13Y output the value of a multiplication result to each input terminal B3-B25 of the adder circuit 14, respectively.

[0036]

On the other hand, if each 1st judgment and coefficient multiplication circuits 13C-13Y judge that the aforementioned absolute value is greater than the noise decision value epsilon, they will choose the pixel value (P22) of a noticed picture element, respectively. Then, each 1st judgment and coefficient multiplication circuits 13C-13Y carry out the multiplication of the filter factor K22 corresponding to the pixel value (P22) of a noticed picture element to the pixel value (P22) of a noticed picture element, respectively. Then, each 1st judgment and coefficient multiplication circuits 13C-13Y output the value of a multiplication result to the input terminals B3-B25 of the adder circuit 14, respectively.

[0037]

The adder circuit 14 adds the value of all the multiplication results input via each input terminal B1-B25. The added value turns into a pixel value (refer to P22' and [Fig.2.](#)) of the noticed picture element which reduced the noise mixed in the aforementioned digital image. The adder circuit 14 outputs noticed picture element value data P22' from the output terminal C1.

[0038]

The adder circuit 14 computes the pixel value (P22') of the noticed picture element which extracted 5x5 regions, respectively and mentioned them above by continuing throughout the aforementioned digital image. The adder circuit 14 outputs sequentially the data of the pixel value (P22') of the computed noticed picture element from the output terminal C1. In the image processing system 10A of this embodiment, using the pixel value (P22') of the aforementioned noticed picture element, the aforementioned digital image was restored and the S/N ratio is improved. Each 1st judgment and coefficient multiplication circuits 13A-13Y, and the adder circuit 14 constitute a spatial filter from this embodiment. Each 1st judgment and coefficient multiplication circuits 13A-13Y, and the adder circuit 14 are computing sequentially the pixel

value (P22') of a noticed picture element by the product sum operation of each filter factor and each pixel value of all the 5x5 regions of the aforementioned digital image which the same weighting was made. Then, since each 1st judgment and coefficient multiplication circuits 13A-13Y can make a product sum operation result what carried out the weighting average of all the pixel values by making the weighting of each filter factor the same, they are equivalent to the smoothing filter of the present invention.

[0039]

In this embodiment, the noise decision value calculation circuit 12 has read and selected the pixel width (noise decision value epsilon) permitted to the pixel value (P22) of a noticed picture element by the look-up table. Therefore, the noise decision value calculation circuit 12 which selects the noise decision value epsilon is equivalent to the selection part of the present invention. In this embodiment, it is equivalent to the selection step of the present invention to read and select the pixel width (noise decision value epsilon) permitted to the pixel value (P22) of a noticed picture element using a look-up table.

[0040]

In this embodiment, the 1st judgment and the coefficient multiplication circuits 13A-13Y are comparing with the aforementioned absolute value the noise decision value epsilon input by the noise decision value calculation circuit 12. Then, as mentioned above, based on the comparison result of the noise decision value epsilon and the aforementioned absolute value the 1st judgment and the coefficient multiplication circuits 13A-13Y, The pixel value (P22) of the noticed picture element by which reduces the noise mixed in the digital image of an object, and is used for calculation of the pixel value (P22') of the noticed picture element which restores this digital image, and multiplication is carried out to a filter factor, and the pixel value (P00-P44 except P22) of a peripheral pixel are chosen, respectively. Thus, the 1st judgment and the coefficient multiplication circuits 13A-13Y reduce a noise, and since they have chosen the pixel value of a peripheral pixel and the pixel value of a noticed picture element which are used for restoration of a digital image, they are equivalent to the correction part of the present invention. In this embodiment, the pixel value (P00-P44 except P22) of a peripheral pixel and the pixel value (P22) of a noticed picture element are equivalent to the correction value of the present invention.

[0041]

According to this embodiment, based on the comparison result of the noise decision value epsilon and the aforementioned absolute value which were selected using the look-up table, it is equivalent to the correction step of the present invention to choose the pixel value (P22) of a noticed picture element and the pixel value (P00-P44 except P22) of a peripheral pixel, respectively.

[0042]

<The effect of Embodiment 1>

In the image processing system 10A of Embodiment 1 mentioned above, the noise decision value calculation circuit 12 has read and selected the noise decision value epsilon according to the pixel value (P22) of a noticed picture element. So, in the image processing system 10A of Embodiment 1, the noise decision value epsilon to select can be changed according to the pixel value (P22) of a noticed picture element.

According to the noise decision value epsilon which was selected by the noise decision value calculation circuit 12 according to the image processing system 10A of this embodiment, Each 1st judgment and coefficient multiplication circuits 13A-13Y have chosen inner either or both sides of the pixel value (P00-P44 except P22) of a peripheral pixel, and the pixel value (P22) of a

noticed picture element as correction value which reduces the noise mixed in the pixel value of five each 5 region. Then, each 1st judgment and coefficient multiplication circuits 13A-13Y can change the correction value to select according to the noise decision value epsilon. Therefore, according to the image processing system 10A of this embodiment, with the correction value selected by each 1st judgment and coefficient multiplication circuits 13A-13Y, the pixel value of the noticed picture element of five each 5 region can be corrected, and the pixel value of the noticed picture element after correction can be made into what reduced the noise.

[0043]

According to the image processing method used for the image processing system 10A of Embodiment 1, the noise decision value epsilon is read and selected according to the pixel value (P22) of a noticed picture element value. Then, according to the image processing method of Embodiment 1, the noise decision value epsilon to select can be changed according to the pixel value (P22) of a noticed picture element.

According to the image processing method used for the image processing system 10A of this embodiment. According to the selected noise decision value epsilon, inner either or both sides of the pixel value (P00-P44 except P22) of a peripheral pixel and the pixel value (P22) of a noticed picture element is chosen as correction value which reduces the noise mixed in the pixel value of five each 5 region. Then, in the image processing method of this embodiment, the correction value to select can be changed according to the noise decision value epsilon. Therefore, according to the image processing method of this embodiment, with the selected correction value, the pixel value of the noticed picture element of five each 5 region can be corrected, and the pixel value of the noticed picture element after correction can be made into what reduced the noise.

[0044]

In the image processing system 10A of this embodiment, each 1st judgment and coefficient multiplication circuits 13A-13Y have set the value of the noise decision value epsilon as 3σ based on the standard deviation σ in distribution of the pixel value of a noticed picture element. Then, according to the image processing system 10A of this embodiment, each 1st judgment and coefficient multiplication circuits 13A-13Y can set the value of the noise decision value epsilon as the value of the pixel value of the noticed picture element centering on the true value of a noticed picture element which contains the whole substantially by setting the noise decision value epsilon as 3σ .

According to the image processing method used for the image processing system 10A of this embodiment, based on the standard deviation σ in distribution of the pixel value of a noticed picture element, the value of the noise decision value epsilon is set as 3σ . Then, according to the image processing method of this embodiment, the value of the noise decision value epsilon can be set as the value of the pixel value of the noticed picture element centering on the true value of a noticed picture element which contains the whole substantially by setting the noise decision value epsilon as 3σ .

[0045]

In the image processing system 10A of this embodiment, the noise decision value epsilon corresponding to the pixel value (P22) of a noticed picture element is memorized as a look-up table in the noise decision value calculation circuit 12. Then, the noise decision value calculation circuit 12 can select easily the noise decision value epsilon over the pixel value (P22) of a noticed picture element by referring to the correspondency of the pixel value (P22) of a noticed picture element, and the noise decision value epsilon.

According to the image processing method used for the image processing system 10A of this embodiment, the noise decision value epsilon is selected by the look-up table in which the correspondency of the pixel value (P22) of a noticed picture element and the noise decision value epsilon was stored. Then, according to the image processing method of this embodiment, the noise decision value epsilon over the pixel value (P22) of a noticed picture element can be easily selected by referring to the correspondency of the pixel value (P22) of a noticed picture element, and the noise decision value epsilon.

[0046]

In the image processing system 10A of this embodiment, being based on the result of having compared the noise decision value epsilon with the absolute value of the result of having subtracted the pixel value (P22) of the noticed picture element from the pixel value (P00-P44 except P22) of a peripheral pixel -- every -- the 1st judgment and the coefficient multiplication circuits 13B-13Y as the aforementioned correction value, Inner either or both sides of the pixel value of a peripheral pixel and the pixel value of a noticed picture element is chosen, respectively. Then, based on the result of having compared the noise decision value epsilon with the aforementioned absolute value, each 1st judgment and coefficient multiplication circuits 13B-13Y can change the correction value to choose.

According to the image processing method used for the image processing system 10A of this embodiment. Based on the result of having compared the noise decision value epsilon with the absolute value of the result of having subtracted the pixel value (P22) of the noticed picture element from the pixel value (P00-P44 except P22) of a peripheral pixel, inner either or both sides of the pixel value of a peripheral pixel and the pixel value of a noticed picture element is chosen as the aforementioned correction value. Then, according to the image processing method of this embodiment, the correction value which chooses the noise decision value epsilon based on the result compared with the aforementioned absolute value can be changed.

[0047]

In the image processing system 10A of this embodiment, By each 1st judgment and coefficient multiplication circuits 13B-13Y, the absolute value of the result of having subtracted the pixel value (P22) of the noticed picture element from the pixel value (P01-P44 except P22) of a peripheral pixel, On condition that it judged that it was below the noise decision value epsilon, the pixel value (P01-P44 except P22) of a peripheral pixel is chosen as the aforementioned correction value, respectively. Then, it can suppress that a noise was not excessively mixed in the pixel value of a noticed picture element, and a noise mixes the pixel value of each peripheral pixel with each selected 1st judgment and coefficient multiplication circuits 13B-13Y in correction value.

According to the image processing system 10A of this embodiment, by each 1st judgment and coefficient multiplication circuits 13B-13Y, The absolute value of the result of having subtracted the pixel value (P22) of the noticed picture element from the pixel value (P01-P44 except P22) of a peripheral pixel chooses the pixel value (P22) of a noticed picture element as the aforementioned correction value, respectively, on condition that it judged that it was larger than the noise decision value epsilon. Then, it can suppress that each 1st judgment and coefficient multiplication circuits 13B-13Y do not choose the pixel value which is the peripheral pixel which the noise mixed excessively as correction value, and a noise mixes them in correction value.

[0048]

According to the image processing method used for the image processing system 10A of this

embodiment. The absolute value of the result of having subtracted the pixel value (P22) of the noticed picture element from the pixel value (P01-P44 except P22) of a peripheral pixel chooses the pixel value (P01-P44 except P22) of a peripheral pixel as the aforementioned correction value, respectively, on condition that it judged that it was below the noise decision value epsilon. Then, it can suppress that a noise was not excessively mixed in the pixel value of a noticed picture element, and a noise mixes the pixel value of each selected peripheral pixel in correction value.

The absolute value of the result of having subtracted the pixel value (P22) of the noticed picture element from the pixel value (P01-P44 except P22) of a peripheral pixel according to the image processing method of this embodiment, On condition that it judged that it was larger than the noise decision value epsilon, the pixel value (P22) of a noticed picture element is chosen as the aforementioned correction value, respectively. Then, the pixel value which is the peripheral pixel in which the noise was mixed excessively as correction value cannot be chosen, and it can suppress that a noise mixes in correction value.

[0049]

this embodiment -- every -- the 1st judgment and the coefficient multiplication circuits 13A-13Y to all the pixel values which consists of either of the pixel values (P00-P44 except P22) of a peripheral pixel and the pixel values (P22) of a noticed picture element with these selected 1st judgment and coefficient multiplication circuits 13A-13Y, or both sides, The multiplication of the filter factor which the same weighting was made is carried out. Then, by adding the value of all the multiplication results, the adder circuit 14 computes sequentially the average value of the pixel value of five reach 5 region, and makes the aforementioned average value the pixel value (P22') of the noticed picture element of five reach 5 region. Then, according to the image processing system 10A of this embodiment, by computing sequentially the average value of the pixel value of five reach 5 region, it can prevent the pixel value which is the peripheral pixel which the noise mixed projecting, and the pixel value (P22') of the corrected noticed picture element can be computed. Therefore, the pixel value (P22') of the corrected noticed picture element reduced the noise.

[0050]

In the image processing method used for the image processing system 10A of this embodiment, The multiplication of the filter factor by which the same weighting was made all the pixel values which consists of either of the selected pixel values (P00-P44 except P22) of a peripheral pixel and pixel values (P22) of a noticed picture element or both sides is carried out. Then, in the image processing method of this embodiment, by adding the value of all the multiplication results, the average value of the pixel value of five reach 5 region is computed sequentially, and the aforementioned average value is made into the pixel value (P22') of the noticed picture element of five reach 5 region. Then, according to the image processing method of this embodiment, by computing sequentially the average value of the pixel value of five reach 5 region, it can prevent the pixel value which is the peripheral pixel which the noise mixed projecting, and the pixel value (P22') of the corrected noticed picture element can be computed. Therefore, the pixel value (P22') of the corrected noticed picture element reduced the noise.

[0051]

<Embodiment 2>

Embodiment 2 of the present invention is described referring to [Fig.5](#) and [Fig.6](#).[Fig.5](#) is a block diagram showing the composition of the image processing system 10B of Embodiment 2. Here, the same composition as Embodiment 1 attaches the same code, and omits the description. The

image processing system 10B is provided with the following.
It is the image memory 11A so that it may illustrate.
Noise decision value calculation circuit 12.
Correction circuits 16A-16H.
Median value calculation circuit 17.

[0052]

The image memory 11A is constituted by SRAM and FF like the image memory 11 of Embodiment 1. The output of the signal conversion section which processes the signal of an image sensor is connected to input terminal IN2 of the image memory 11A. The input terminal of the noise decision value calculation circuit 12 is connected to the noticed picture element value output terminal D1 of the image memory 11A.

[0053]

The 1st input terminal of the correction circuit 16A is connected to the output terminal of the noise decision value calculation circuit 12. The 2nd input terminal of the correction circuit 16A is connected to the peripheral pixel value output terminal D2 of the image memory 11A. The 3rd input terminal of the correction circuit 16A is connected to the noticed picture element value output terminal D1 of the image memory 11A.

[0054]

Each 1st input terminal of the correction circuits 16B-16H is connected to the output terminal of the noise decision value calculation circuit 12 as well as the 1st input terminal of the correction circuit 16A. Each 2nd input terminal of the correction circuits 16B-16H is connected to the peripheral pixel value output terminals D2-D9 of the image memory 11A, respectively. Each 3rd input terminal of the correction circuits 16B-16H is connected to the noticed picture element value output terminal D1 of the image memory 11A.

[0055]

The input terminal E1 of the median value calculation circuit 17 is connected to the noticed picture element value output terminal D1 of the image memory 11A. Each input terminal E2-E9 of the median value calculation circuit 17 is connected to each output terminal of the correction circuits 16A-16H, respectively. The median value calculation circuit 17 is constituted from Embodiment 2 by the median filter. Code F1 in a figure is an output terminal of the median value calculation circuit 17.

[0056]

Next, it describes about the image processing method of the image processing system 10B of Embodiment 2. The image memory 11A memorizes the data of the digital image of an object for every line data like the image memory 11 of Embodiment 1.

[0057]

In the image processing system 10B of this embodiment, the image memory 11A extracts 3x3 every 3 pixels regions from the data of the digital image memorized by the image memory 11A to X-direction and Y-direction, respectively so that it may illustrate to Fig.6. Q11 in a figure shows noticed picture element value data, and all the codes Q00-Q22 other than Q11 show peripheral pixel value data. According to this embodiment, what deleted noise data from the noticed picture element value data Q11 is equivalent to the true value of the noticed picture element of the present invention.

[0058]

In the image processing system 10B, the image memory 11A outputs the noticed picture element

value data Q11 to the input terminal E1 of the noise decision value calculation circuit 12, each correction circuit 16A-16H, and the median value calculation circuit 17 from the noticed picture element value output terminal D1. In addition, the image memory 11A outputs the peripheral pixel value data Q00 etc. to each correction circuit 16A-16H, respectively from each peripheral pixel value output terminal D2-D9.

[0059]

The noise decision value epsilon corresponding to the aforementioned noticed picture element value data Q11 is memorized as a look-up table in the noise decision value calculation circuit 12. The noise decision value calculation circuit 12 outputs the data of reading and this noise decision value epsilon for the noise decision value epsilon to each correction circuit 16A-16H from a look-up table according to the aforementioned noticed picture element value data Q11.

[0060]

As mentioned above, the noticed picture element value data Q11 of the noise decision value epsilon, such as data and the peripheral pixel value data Q00, is input into the correction circuits 16A-16H, respectively.

[0061]

The correction circuit 16A subtracts the pixel value (Q11) of a noticed picture element from the pixel value (Q00) of a peripheral pixel first. Next, the correction circuit 16A compares the absolute value of the subtracted result with the aforementioned noise decision value epsilon. If the correction circuit 16A judges that the aforementioned absolute value is below the noise decision value epsilon, it will choose the pixel value (Q00) of a peripheral pixel. Then, the correction circuit 16A outputs the peripheral pixel value data Q00 to the input terminal E2 of the median value calculation circuit 17.

[0062]

On the other hand, if the correction circuit 16A judges that the aforementioned absolute value is greater than the noise decision value epsilon, it will choose the pixel value (Q11) of a noticed picture element. Then, the correction circuit 16A outputs the noticed picture element value data Q11 to the input terminal E2 of the median value calculation circuit 17.

[0063]

Each correction circuit 16B-16H subtracts the pixel value (Q11) of a noticed picture element from the pixel value (Q01-Q22 except Q00) of a peripheral pixel like the correction circuit 16A mentioned above, respectively. Next, each correction circuit 16B-16H compares the absolute value of the subtracted result with the aforementioned noise decision value epsilon, respectively. If each correction circuit 16B-16H judges that each absolute value is below the noise decision value epsilon, it will choose the pixel value (Q01-Q22 except Q00) of a peripheral pixel, respectively. Then, each correction circuit 16B-16H outputs the peripheral pixel value data Q10-Q22 to each input terminal E3-E9 of the median value calculation circuit 17, respectively.

[0064]

On the other hand, if it judges that the aforementioned absolute value of each correction circuit 16B-16H is greater than the noise decision value epsilon, the pixel value (Q11) of a noticed picture element will be chosen, respectively. Then, each correction circuit 16B-16H outputs the noticed picture element value data Q11 to each input terminal E2-E9 of the median value calculation circuit 17, respectively.

[0065]

As mentioned above, noticed picture element value data is input into the median value calculation circuit 17 via the input terminal E1. In addition, in the median value calculation

circuit 17, as mentioned above, according to the comparison result of the absolute value of a result and the noise decision value epsilon which subtracted the pixel value of the noticed picture element from the pixel value of a peripheral pixel by each correction circuit 16A-16H, Peripheral pixel value data or noticed picture element value data is input via the input terminals E2-E9. All the input pixel values are arranged in an order from what has a large value, and the median value calculation circuit 17 changes them. And the median value calculation circuit 17 is calculating the median value (mean value) of the values put in order and changed as a pixel value (Q11') of the noticed picture element of 3x3 regions. A median value (mean value) is calculated as a pixel value (Q11') of a noticed picture element, in order to reduce the noise mixed in the aforementioned digital image. Then, the median value calculation circuit 17 outputs output terminal F1 to median value data Q11'.

[0066]

As the median value calculation circuit 17 continued throughout the aforementioned digital image, and 3x3 regions are extracted, respectively and were mentioned above, the median value is sequentially calculated as a pixel value (Q11') of a noticed picture element. The median value calculation circuit 17 outputs sequentially computed noticed picture element value data Q11' from output terminal F1. In the image processing system 10B of this embodiment, using the aforementioned median value, the aforementioned digital image was restored and the S/N ratio is improved.

[0067]

In this embodiment, the correction circuits 16A-16H, As a median value used for restoration of a digital image according to the comparison result of the absolute value of a result and the noise decision value epsilon which subtracted the pixel value of the noticed picture element from the pixel value of a peripheral pixel, since the pixel value of a peripheral pixel or the pixel value of a noticed picture element is chosen, it is equivalent to the correction part of the present invention. In this embodiment, the pixel value (Q01-Q22 except Q11) of a peripheral pixel and the pixel value (Q11) of a noticed picture element are equivalent to the correction value of the present invention. In this embodiment, the noise decision value calculation circuit 12 has read and selected the pixel width (noise decision value epsilon) permitted to the pixel value (Q11) of a noticed picture element by the look-up table. Therefore, the noise decision value calculation circuit 12 which selects the noise decision value epsilon is equivalent to the selection part of the present invention.

[0068]

According to this embodiment, according to the comparison result of the absolute value of a result and the noise decision value epsilon which subtracted the pixel value of the noticed picture element from the pixel value of a peripheral pixel, it is equivalent to the correction step of the present invention to choose the pixel value of a peripheral pixel or the pixel value of a noticed picture element as a median value used for restoration of a digital image. In this embodiment, it is equivalent to the selection step of the present invention to read and select the pixel width (noise decision value epsilon) permitted to the pixel value (Q11) of a noticed picture element using a look-up table.

[0069]

<The effect of Embodiment 2>

In the image processing system 10B of Embodiment 2 mentioned above, the noise decision value calculation circuit 12 has read and selected the noise decision value epsilon according to the pixel value (Q11) of a noticed picture element. So, in the image processing system 10B of

Embodiment 2, the noise decision value epsilon to select can be changed according to the pixel value (Q11) of a noticed picture element.

According to the image processing system 10B of this embodiment, according to the noise decision value epsilon selected by the noise decision value calculation circuit 12, each correction circuit 16A-16H as correction value which reduces the noise mixed in the pixel value of three xeach 3 region, Inner either or both sides of the pixel value (Q00-Q22 except Q11) of a peripheral pixel and the pixel value (Q11) of a noticed picture element is chosen. Then, each correction circuit 16A-16H can change the correction value to select according to the noise decision value epsilon. Therefore, according to the image processing system 10B of this embodiment, with the correction value selected by each correction circuit 16A-16H, the pixel value of the noticed picture element of three xeach 3 region can be corrected, and the pixel value of the noticed picture element after correction can be made into what reduced the noise.

[0070]

According to the image processing method used for the image processing system 10B of Embodiment 2, the noise decision value epsilon is read and selected according to the pixel value (Q11) of a noticed picture element. Then, according to the image processing method of Embodiment 2, the noise decision value epsilon to select can be changed according to the pixel value (Q11) of a noticed picture element.

According to the image processing method used for the image processing system 10B of this embodiment. According to the selected noise decision value epsilon, inner either or both sides of the pixel value (Q00-Q22 except Q11) of a peripheral pixel and the pixel value (Q11) of a noticed picture element is chosen as correction value which reduces the noise mixed in the pixel value of three xeach 3 region. Then, in the image processing method of this embodiment, the correction value to select can be changed according to the noise decision value epsilon. Therefore, according to the image processing method of this embodiment, with the selected correction value, the pixel value of the noticed picture element of three xeach 3 region can be corrected, and the pixel value of the noticed picture element after correction can be made into what reduced the noise.

[0071]

In the image processing system 10B of this embodiment, Based on the result compared with the absolute value of the result of having subtracted the pixel value (Q11) of the noticed picture element from the pixel value (Q00-Q22 except Q11) of a peripheral pixel, each correction circuit 16A-16H the noise decision value epsilon as the aforementioned correction value, Inner either or both sides of the pixel value of a peripheral pixel and the pixel value of a noticed picture element is chosen, respectively. Then, based on the result of having compared the noise decision value epsilon with the aforementioned absolute value, each correction circuit 16A-16H can change the correction value to choose.

According to the image processing method used for the image processing system 10B of this embodiment. Based on the result of having compared the noise decision value epsilon with the absolute value of the result of having subtracted the pixel value (Q11) of the noticed picture element from the pixel value (Q00-Q22 except Q11) of a peripheral pixel, inner either or both sides of the pixel value of a peripheral pixel and the pixel value of a noticed picture element is chosen as the aforementioned correction value. Then, according to the image processing method of this embodiment, the correction value which chooses the noise decision value epsilon based on the result compared with the aforementioned absolute value can be changed.

[0072]

In the image processing system 10B of this embodiment, On condition that it judged that it was below the noise decision value epsilon, by each correction circuit 16A-16H, the absolute value of the result of having subtracted the pixel value (Q11) of the noticed picture element from the pixel value (Q00-Q22 except Q11) of a peripheral pixel as the aforementioned correction value, The pixel value (Q00-Q22 except Q11) of a peripheral pixel is chosen, respectively. Then, it can suppress that a noise was not excessively mixed in the pixel value of a noticed picture element, and a noise mixes the pixel value of each peripheral pixel with each selected correction circuit 16A-16H in correction value.

According to the image processing system 10B of this embodiment, by each correction circuit 16A-16H, The absolute value of the result of having subtracted the pixel value (Q11) of the noticed picture element from the pixel value (Q00-Q22 except Q11) of a peripheral pixel chooses the pixel value (Q11) of a noticed picture element as the aforementioned correction value, respectively, on condition that it judged that it was larger than the noise decision value epsilon. Then, it can suppress that each correction circuit 16A-16H does not choose the pixel value which is the peripheral pixel which the noise mixed excessively as correction value, and a noise mixes it in correction value.

[0073]

According to the image processing method used for the image processing system 10B of this embodiment. The absolute value of the result of having subtracted the pixel value (Q11) of the noticed picture element from the pixel value (Q00-Q22 except Q11) of a peripheral pixel chooses the pixel value (Q00-Q22 except Q11) of a peripheral pixel as the aforementioned correction value, respectively, on condition that it judged that it was below the noise decision value epsilon. Then, it can suppress that a noise was not excessively mixed in the pixel value of a noticed picture element, and a noise mixes the pixel value of each selected peripheral pixel in correction value.

The absolute value of the result of having subtracted the pixel value (Q11) of the noticed picture element from the pixel value (Q00-Q22 except Q11) of a peripheral pixel according to the image processing method of this embodiment, On condition that it judged that it was larger than the noise decision value epsilon, the pixel value (Q11) of a noticed picture element is chosen as the aforementioned correction value, respectively. Then, the pixel value which is the peripheral pixel which the noise mixed excessively as correction value cannot be chosen, and it can suppress that a noise mixes in correction value.

[0074]

In the image processing system 10B of this embodiment, The median value calculation circuit 17 is calculating the median value from all the pixel values which consists of either of the pixel values (Q00-Q22 except Q11) of a peripheral pixel and the pixel values (Q11) of a noticed picture element with each selected correction circuit 16A-16H, or both sides. And the image processing system 10B of this embodiment calculates sequentially the median value of three xeach 3 region, and makes the aforementioned median value the pixel value (Q11') of the noticed picture element of three xeach 3 region. Then, the median value calculated by the median value calculation circuit 17 reduced the noise compared with the pixel value which is the peripheral pixel which the noise mixed. Therefore, according to the image processing system 10B of this embodiment, the pixel value (Q11') of the noticed picture element which becomes settled with a median value reduced the noise.

[0075]

In the image processing method used for the image processing system 10B of this embodiment,

the median value is calculated from all the pixel values which consists of either of the selected pixel values (Q00-Q22 except Q11) of a peripheral pixel and pixel values (Q11) of a noticed picture element, or both sides. And in the image processing method of this embodiment, the median value of three each 3 region is calculated sequentially, and the aforementioned median value is made into the pixel value (Q11') of the noticed picture element of three each 3 region. Then, the median value calculated reduced the noise compared with the pixel value which is the peripheral pixel which the noise mixed. Therefore, according to the image processing method of this embodiment, the pixel value (Q11') of the noticed picture element which becomes settled with a median value reduced the noise.

[0076]

<Embodiment 3>

Embodiment 3 of the present invention is described referring to Fig.7. Fig.7 is a block diagram showing the composition of the image processing system 10C of Embodiment 3. Here, the same composition as Embodiment 1 and Embodiment 2 attaches the same code, and omits the description. The image processing system 10C is provided with the following.

It is the image memory 11A so that it may illustrate.

Noise decision value calculation circuit 12.

Median value calculation circuit 17.

Pixel value determining circuit 18.

[0077]

The output of the signal conversion section which processes the signal of an image sensor is connected to the image memory 11A like Embodiment 2. The input terminal of the noise decision value calculation circuit 12 is connected to the noticed picture element value output terminal D1 of the image memory 11A. The input terminal E1 of the median value calculation circuit 17 is connected to the noticed picture element value output terminal D1 of the image memory 11A. Each input terminal E2-E9 of the median value calculation circuit 17 is connected to each peripheral pixel value output terminal D2-D9 of the image memory 11A, respectively.

[0078]

The 1st input terminal of the pixel value determining circuit 18 is connected to the noticed picture element value output terminal D1 of the image memory 11A. The 2nd input terminal of the pixel value determining circuit 18 is connected to the output terminal of the noise decision value calculation circuit 12. The 3rd input terminal of the pixel value determining circuit 18 is connected to output terminal F1 of the median value calculation circuit 17. The code G1 in a figure is an output terminal of the pixel value determining circuit 18.

[0079]

Next, it describes about the image processing method of the image processing system 10C of Embodiment 3. In the image processing system 10C of this embodiment, 3x3 every 3 pixels regions are extracted from the data of the digital image memorized by the image memory 11A to X-direction and Y-direction like Embodiment 2, respectively.

[0080]

In the image processing system 10C, the image memory 11A outputs the noticed picture element value data Q11 to the input terminal E1 of the noise decision value calculation circuit 12 and the median value calculation circuit 17, and the 1st input terminal of the pixel value determining circuit 18 from the noticed picture element value output terminal D1. In addition, the image memory 11A outputs the peripheral pixel value data Q00 etc. to each input terminal E2-E9 of the

median value calculation circuit 17, respectively from each peripheral pixel value output terminal D2-D9.

[0081]

The noise decision value calculation circuit 12 outputs the data of the noise decision value epsilon to the 2nd input terminal of the pixel value determining circuit 18. The noticed picture element value data Q11 is input into the median value calculation circuit 17 via the input terminal E1. In addition, as mentioned above, the peripheral pixel value data Q00 etc. are input into the median value calculation circuit 17 via each input terminal E2-E9. The median value calculation circuit 17 is calculating the median value like Embodiment 2. Then, the median value calculation circuit 12 outputs the data of a median value to the 3rd input terminal of the pixel value determining circuit 18 from output terminal F1.

[0082]

As mentioned above, the noticed picture element value data Q11, the data of the noise decision value epsilon, and the data of the median value are input into the pixel value determining circuit 18, respectively. The pixel value determining circuit 18 subtracts the picture value (Q11) of a noticed picture element from a median value first. Next, the pixel value determining circuit 18 compares the absolute value of a subtraction result with the noise decision value epsilon. If the pixel value determining circuit 18 judges that the aforementioned absolute value is below the noise decision value epsilon, it will choose a median value. Then, the pixel value determining circuit 18 outputs the data of a median value from the output terminal G1.

[0083]

On the other hand, if it judges that the aforementioned absolute value of the pixel value determining circuit 18 is greater than the noise decision value epsilon, the pixel value (Q11) of a noticed picture element will be chosen. Then, the pixel value determining circuit 18 outputs the noticed picture element value data Q11 from the output terminal G1.

[0084]

In the image processing system 10C of this embodiment, the median value calculation circuit 17 continues throughout the digital image of an object, 3x3 regions are extracted, respectively, and the median value is calculated every three xeach 3 region. And the pixel value determining circuit 18 compares the absolute value of the aforementioned subtraction result with the noise decision value epsilon sequentially, and has chosen sequentially the median value or the pixel value (Q11) of a noticed picture element as a pixel value (Q11') of a noticed picture element according to a comparison result. Then, the pixel value determining circuit 18 outputs sequentially the data or the noticed picture element value data Q11 of a median value from output terminal F1. A median value or the pixel value (Q11) of a noticed picture element is chosen as a pixel value (Q11') of a noticed picture element, in order to reduce the noise mixed in the aforementioned digital image. Using the aforementioned median value or the pixel value (Q11) of the aforementioned noticed picture element, the image processing system 10C restored the aforementioned digital image, and has improved the S/N ratio.

[0085]

In this embodiment, the pixel value determining circuit 18 according to the comparison result of the absolute value of a result and the noise decision value epsilon which subtracted the picture value (Q11) of the noticed picture element from the median value, Since the median value used for restoration of a digital image or the pixel value (Q11) of a noticed picture element is chosen, it is equivalent to the correction part of the present invention. In this embodiment, a median value and the pixel value (Q11) of a noticed picture element are equivalent to the correction

value of the present invention. The noise decision value calculation circuit 12 is equivalent to the selection part of the present invention like Embodiment 2.

[0086]

According to this embodiment, it is equivalent to the correction step of the present invention to choose the median value used for restoration of a digital image or the pixel value (Q11) of a noticed picture element according to the comparison result of the absolute value of a result and the noise decision value epsilon which subtracted the picture value (Q11) of the noticed picture element from the median value. The selection step of the present invention is constituted from this embodiment by the same processing as Embodiment 2.

[0087]

<The effect of Embodiment 3>

In the image processing system 10C of Embodiment 3 mentioned above, the noise decision value calculation circuit 12 has read and selected the noise decision value epsilon according to the pixel value (Q11) of a noticed picture element. So, in the image processing system 10C of Embodiment 3, the noise decision value epsilon to select can be changed according to the pixel value (Q11) of a noticed picture element.

According to the image processing system 10C of this embodiment, according to the noise decision value epsilon selected by the noise decision value calculation circuit 12, the pixel value determining circuit 18 as correction value which reduces the noise mixed in the pixel value of three xeach 3 region, Either one of the median value which is either of the pixel values (Q00-Q22 except Q11) of a peripheral pixel, or the pixel value (Q11) of a noticed picture element is chosen. Then, the pixel value determining circuit 18 can change the correction value to select according to the noise decision value epsilon. Therefore, according to the image processing system 10C of this embodiment, with the correction value selected by the picture value determining circuit 18, the pixel value of the noticed picture element of three xeach 3 region can be corrected, and the pixel value of the noticed picture element after correction can be made into what reduced the noise.

[0088]

According to the image processing method used for the image processing system 10C of Embodiment 3, the noise decision value epsilon is read and selected according to the pixel value (Q11) of a noticed picture element. Then, according to the image processing method of Embodiment 3, the noise decision value epsilon to select can be changed according to the pixel value (Q11) of a noticed picture element.

According to the image processing method used for the image processing system 10C of this embodiment. According to the selected noise decision value epsilon, either one of the median value which is either of the pixel values (Q00-Q22 except Q11) of a peripheral pixel, or the pixel value (Q11) of a noticed picture element is chosen as correction value which reduces the noise mixed in the pixel value of three xeach 3 region. Then, in the image processing method of this embodiment, the correction value to select can be changed according to the noise decision value epsilon. Therefore, according to the image processing method of this embodiment, with the selected correction value, the pixel value of the noticed picture element of three xeach 3 region can be corrected, and the pixel value of the noticed picture element after correction can be made into what reduced the noise.

[0089]

In the image processing system 10C of this embodiment, the pixel value determining circuit 18 chooses a median value or the pixel value (Q11) of a noticed picture element as the

aforementioned correction value based on the result of having compared the noise decision value epsilon with the absolute value of the result of having subtracted the pixel value (Q11) of the noticed picture element from the median value. Then, based on the result of having compared the noise decision value epsilon with the aforementioned absolute value, the pixel value determining circuit 18 can change the correction value to choose.

According to the image processing method used for the image processing system 10C of this embodiment. Based on the result of having compared the noise decision value epsilon with the absolute value of the result of having subtracted the pixel value (Q11) of the noticed picture element from the median value, a median value or the pixel value (Q11) of a noticed picture element is chosen as the aforementioned correction value. Then, the correction value which chooses the noise decision value epsilon based on the result compared with the aforementioned absolute value can be changed.

[0090]

In the image processing system 10C of this embodiment, the absolute value of the result of having subtracted the pixel value (Q11) of the noticed picture element from the median value chooses a median value as the aforementioned correction value by the pixel value determining circuit 18, on condition that it judged that it was below the noise decision value epsilon. Then, it can suppress that a noise was not excessively mixed in the pixel value of a noticed picture element, and a noise mixes the median value with the selected pixel value determining circuit 18 in correction value.

According to the image processing system 10C of this embodiment, the absolute value of the result of having subtracted the pixel value (Q11) of the noticed picture element from the median value chooses the pixel value (Q11) of a noticed picture element as the aforementioned correction value by the pixel value determining circuit 18, on condition that it judged that it was larger than the noise decision value epsilon. Then, it can suppress that the pixel value determining circuit 18 does not choose the median value which the noise mixed excessively as correction value, and a noise mixes it in correction value.

[0091]

According to the image processing method used for the image processing system 10C of this embodiment, the absolute value of the result of having subtracted the pixel value (Q11) of the noticed picture element from the median value chooses a median value as the aforementioned correction value, on condition that it judged that it was below the noise decision value epsilon. Then, it can suppress that a noise was not excessively mixed in the pixel value of a noticed picture element, and a noise mixes the selected median value in correction value.

According to the image processing method of this embodiment, the absolute value of the result of having subtracted the pixel value (Q11) of the noticed picture element from the median value chooses the pixel value (Q11) of a noticed picture element as the aforementioned correction value, on condition that it judged that it was larger than the noise decision value epsilon. Then, the median value which the noise mixed excessively cannot be chosen as correction value, and it can suppress that a noise mixes in correction value.

[0092]

<Embodiment 4>

Embodiment 4 of the present invention is described referring to Fig.8. Fig.8 is a block diagram showing the composition of the image processing system 10D of Embodiment 4. Here, the same composition as Embodiment 1 thru/or Embodiment 3 attaches the same code, and omits the description. The image processing system 10D is provided with the following.

It is the image memory 11A so that it may illustrate.
Noise decision value calculation circuit 12.
The 2nd judgment and the coefficient multiplication circuits 19A-19H.
Adding and subtracting circuit 20.

[0093]

The output of the signal conversion section which processes the signal of an image sensor is connected to the image memory 11A like Embodiment 2 and Embodiment 3. The input terminal of the noise decision value calculation circuit 12 is connected to the noticed picture element value output terminal D1 of the image memory 11A.

[0094]

The 1st input terminal of the 2nd judgment and the coefficient multiplication circuit 19A is connected to the output terminal of the noise decision value calculation circuit 12. The 2nd input terminal of the 2nd judgment and the coefficient multiplication circuit 19A is connected to the noticed picture element value output terminal D1 of the image memory 11A.

[0095]

The 1st input terminal of the 2nd judgment and the coefficient multiplication circuit 19B is connected to the output terminal of the noise decision value calculation circuit 12. The 2nd input terminal of the 2nd judgment and the coefficient multiplication circuit 19B is connected to the peripheral pixel value output terminal D2 of the image memory 11A. The 3rd input terminal of the 2nd judgment and the coefficient multiplication circuit 19B is connected to the noticed picture element value output terminal D1 of the image memory 11A.

[0096]

Each 1st input terminal of the 2nd judgment and the coefficient multiplication circuits 19C-19H is connected to the output terminal of the noise decision value calculation circuit 12 as well as the 1st input terminal of the 2nd judgment and the coefficient multiplication circuit 19B. Each 2nd input terminal of the 2nd judgment and the coefficient multiplication circuits 19C-19H is connected to the peripheral pixel value output terminals D3-D9 of the image memory 11A, respectively. Each 3rd input terminal of the 2nd judgment and the coefficient multiplication circuits 19C-19H is connected to the noticed picture element value output terminal D1 of the image memory 11A.

[0097]

The input terminal H1 of the adding and subtracting circuit 20 is connected to the noticed picture element value output terminal D1 of the image memory 11A. The input terminals H2-H9 of the adding and subtracting circuit 20 are connected to the output terminal of the 2nd judgment and the coefficient multiplication circuits 19A-19H, respectively. The code I1 in a figure is an output terminal of the adding and subtracting circuit 20.

[0098]

Next, it describes about the image processing method of the image processing system 10D of Embodiment 4. In the image processing system 10D of this embodiment, the 3x3 aforementioned regions are extracted from the data of the digital image memorized by the image memory 11A like Embodiment 2 and Embodiment 3.

[0099]

In the image processing system 10D, the image memory 11A outputs the noticed picture element value data Q11 to the input terminal H1 of the noise decision value calculation circuit 12, each 2nd judgment and coefficient multiplication circuits 19A-19H, and the adding and subtracting

circuit 20 from the noticed picture element value output terminal D1. In addition, the image memory 11A outputs the peripheral pixel value data Q00 etc. to the 2nd input terminal of each 2nd judgment and coefficient multiplication circuits 19B-19H, respectively from each peripheral pixel value output terminal D2-D9.

[0100]

The noise decision value calculation circuit 12 outputs the data of the noise decision value epsilon to the 1st input terminal of each 2nd judgment and coefficient multiplication circuits 19A-19H. The noticed picture element value data Q11 and the data of the noise decision value epsilon are input into the 2nd judgment and the coefficient multiplication circuit 19A. The data of the noise decision value epsilon of the noticed picture element value data Q11, the peripheral pixel value data Q00, etc. is input into each 2nd judgment and coefficient multiplication circuits 19B-19H, respectively.

[0101]

The 2nd judgment and the coefficient multiplication circuit 19A subtract the pixel value (Q11) of a noticed picture element from the pixel value (Q11) of a noticed picture element first. Next, the 2nd judgment and the coefficient multiplication circuit 19A compare the absolute value of a subtraction result with the noise decision value epsilon. The 2nd judgment and the coefficient multiplication circuit 19A judge that the aforementioned absolute value is below the noise decision value epsilon, and chooses the value of the aforementioned subtraction result.

[0102]

Then, the 2nd judgment and the coefficient multiplication circuit 19A carry out the multiplication of the smoothing coefficient to the value of the aforementioned subtraction result. Then, the 2nd judgment and the coefficient multiplication circuit 19A output the value of a multiplication result to the input terminal H2 of the adding and subtracting circuit 20.

[0103]

The 2nd judgment and the coefficient multiplication circuit 19B subtract the pixel value (Q11) of a noticed picture element from the pixel value (Q00) of a peripheral pixel first. Next, the 2nd judgment and the coefficient multiplication circuit 19B compare the absolute value of a subtraction result with the noise decision value epsilon. If the 2nd judgment and the coefficient multiplication circuit 19B judge that the aforementioned absolute value is below the noise decision value epsilon, it will select the value of the aforementioned subtraction result.

[0104]

Then, the 2nd judgment and the coefficient multiplication circuit 19B carry out the multiplication of the smoothing coefficient to the value of the aforementioned subtraction result. Then, the 2nd judgment and the coefficient multiplication circuit 19B output the value of a multiplication result to the input terminal H3 of the adding and subtracting circuit 20.

[0105]

On the other hand, if the 2nd judgment and the coefficient multiplication circuit 19B judge that the aforementioned absolute value is greater than the noise decision value epsilon, it will choose the value set up previously. According to this embodiment, if the 2nd judgment and the coefficient multiplication circuit 19B judge that the aforementioned absolute value is greater than the noise decision value epsilon, it will choose the pixel value (Q11) of a noticed picture element. Then, the 2nd judgment and the coefficient multiplication circuit 19B carry out the multiplication of the smoothing coefficient to the pixel value (Q11) of a noticed picture element. Then, the 2nd judgment and the coefficient multiplication circuit 19B output the value of a multiplication result to the input terminal H3 of the adding and subtracting circuit 20.

[0106]

Each 2nd judgment and coefficient multiplication circuits 19C-19H subtract the pixel value (Q11) of a noticed picture element from the pixel value (Q01-Q22 except Q00 and Q11) of a peripheral pixel, respectively like the 2nd judgment and the coefficient multiplication circuit 19B mentioned above. Next, the 2nd judgment and the coefficient multiplication circuits 19C-19H compare the absolute value of a subtraction result with the aforementioned noise decision value epsilon, respectively. If each 2nd judgment and coefficient multiplication circuits 19C-19H judge that each absolute value is below the noise decision value epsilon, they will choose the value of the aforementioned subtraction result, respectively.

[0107]

Then, each 2nd judgment and coefficient multiplication circuits 19C-19H carry out the multiplication of the smoothing coefficient to the value of the aforementioned subtraction result. Then, each 2nd judgment and coefficient multiplication circuits 19C-19H output the value of a multiplication result to each input terminal H4-H9 of the adding and subtracting circuit 20, respectively.

[0108]

On the other hand, if it judges that each 2nd judgment and coefficient multiplication circuits 19C-19H have an absolute value of a subtraction result greater than the noise decision value epsilon, the pixel value (Q11) of a noticed picture element will be chosen like above-mentioned 2nd judgment and coefficient multiplication circuit 19B. Then, each 2nd judgment and coefficient multiplication circuits 19C-19H carry out the multiplication of the smoothing coefficient to the pixel value (Q11) of a noticed picture element. Then, each 2nd judgment and coefficient multiplication circuits 19C-19H output the value of a multiplication result to the input terminals H4-H9 of the adding and subtracting circuit 20, respectively.

[0109]

The adding and subtracting circuit 20 adds the value of all the multiplication results input into each input terminal H2-H9 first. Then, the adding and subtracting circuit 20 adds or subtracts the value of the aforementioned multiplication result to the pixel value (Q11) of the noticed picture element input into the input terminal H1. Here, since the aforementioned subtraction result has a positive value, when the aforementioned multiplication result has a positive value, the adding and subtracting circuit 20 adds the value of a multiplication result to the pixel value (Q11) of a noticed picture element. On the other hand, since the aforementioned subtraction result has a negative value, when the aforementioned multiplication result has a negative value, the adding and subtracting circuit 20 subtracts the value of the aforementioned multiplication result from the pixel value (Q11) of a noticed picture element.

[0110]

The value which added or subtracted the aforementioned multiplication result to the pixel value (Q11) of the noticed picture element turns into a pixel value (Q11') of the noticed picture element for reducing the noise mixed in the aforementioned digital image. The adding and subtracting circuit 20 outputs noticed picture element value data Q11' from the output terminal I1.

[0111]

The adding and subtracting circuit 20 computes the pixel value (Q11') of the noticed picture element which extracted 3x3 regions, respectively and mentioned them above by continuing throughout the aforementioned digital image. The adding and subtracting circuit 20 outputs sequentially computed noticed picture element value data Q11' from the output terminal I1. In the image processing system 10D of this embodiment, using the pixel value (Q11') of the

aforementioned noticed picture element, the aforementioned digital image was restored and the S/N ratio is improved. Each 2nd judgment and coefficient multiplication circuits 19A-19H, and the adding and subtracting circuit 20 constitute the epsilon filter 30 from this embodiment.

[0112]

this embodiment -- every -- the 2nd judgment and the coefficient multiplication circuits 19B-19H are comparing the noise decision value epsilon with the absolute value of the value which subtracted the pixel value (Q11) of the noticed picture element from the pixel value (Q01-Q22 except Q11) of a peripheral pixel. Therefore, the noise decision value epsilon in comparison with the aforementioned absolute value is equivalent to the reference value of the present invention. The noise decision value calculation circuit 12 is equivalent to the selection part of the present invention like Embodiment 1 thru/or Embodiment 3.

[0113]

According to this embodiment, it is equivalent to the comparison step of the present invention to compare the noise decision value epsilon with the absolute value of the value which subtracted the pixel value (Q11) of the noticed picture element from the pixel value (Q01-Q22 except Q11) of a peripheral pixel. It is equivalent to the selection step of the present invention to read and select the pixel width (noise decision value epsilon) permitted to the pixel value (Q11) of a noticed picture element like Embodiment 1 thru/or Embodiment 3 using a look-up table.

[0114]

<The effect of Embodiment 4>

In the image processing system 10D of Embodiment 4 mentioned above, the noise decision value calculation circuit 12 has read and selected the noise decision value epsilon according to the pixel value (Q11) of a noticed picture element. So, in the image processing system 10D of Embodiment 4, the noise decision value epsilon to select can be changed according to the pixel value (Q11) of a noticed picture element.

In the image processing system 10D of this embodiment, The epsilon filter 30 makes the noise decision value epsilon selected by the noise decision value calculation circuit 12 the reference value in comparison with the absolute value of the value which subtracted the pixel value (Q11) of the noticed picture element, respectively from the pixel value (Q00-Q22 except Q11) of the peripheral pixel. Then, according to the image processing system 10D of this embodiment, the aforementioned reference value will change with the noise decision value epsilon selected according to the pixel value (Q11) of a noticed picture element, and can change the reference value used with the epsilon filter 30 according to the pixel value (Q11) of a noticed picture element.

[0115]

According to the image processing method used for the image processing system 10D of Embodiment 4, the noise decision value epsilon is read and selected according to the pixel value (Q11) of a noticed picture element. Then, according to the image processing method of Embodiment 4, the noise decision value epsilon to select can be changed according to the pixel value (Q11) of a noticed picture element.

According to the image processing method used for the image processing system 10D of this embodiment, the selected noise decision value epsilon is compared with the absolute value of the value which subtracted the pixel value (Q11) of the noticed picture element from the pixel value (Q00-Q22 except Q11) of a peripheral pixel, respectively. Then, according to the image processing method of this embodiment, the noise decision value epsilon in comparison with the aforementioned absolute value can be changed according to the pixel value (Q11) of a noticed

picture element, it can be made to be able to respond to change of the pixel value (Q11) which is a noticed picture element, and the optimal noise decision value epsilon can be selected.

[0116]

The present invention is not limited to the embodiment mentioned above, and within limits which do not deviate from the meaning of invention, a part of composition can be changed suitably, and it can carry it out to them. For example, the noise decision value calculation circuit 12 may be made to memorize the approximate expression showing the correspondency of a pixel value of a noticed picture element value and the noise decision value epsilon which are replaced with a look-up table and illustrated as the solid line in Fig.9 unlike the embodiment mentioned above. The formula which expresses faithfully the correspondency of a pixel value of a noticed picture element and the noise decision value epsilon which are illustrated with the dashed line in Fig.9 by this is used, The burden required in order that the noise decision value calculation circuit 12 may compute the noise decision value epsilon can be made to ease compared with the case where the noise decision value calculation circuit 12 computes the noise decision value epsilon according to the pixel value of the noticed picture element. Then, the circuit configuration of the noise decision value calculation circuit 12 can be simplified in accordance with the burden required in order to compute the noise decision value epsilon being eased.

The noise decision value epsilon may be computed using the approximate expression showing the correspondency of a pixel value of a noticed picture element and the noise decision value epsilon which unlike the image processing method of an embodiment mentioned above are replaced with a look-up table and illustrated as the solid line in Fig.9. The burden required in order to compute the noise decision value epsilon by this compared with the case where the noise decision value epsilon according to the pixel value of the noticed picture element is computed using the formula which expresses faithfully the correspondency of a pixel value of a noticed picture element and the noise decision value epsilon which are illustrated with the dashed line in Fig.9 can be made to ease.

[0117]

It may differ in Embodiment 1 mentioned above, and the weighting of each filter factor of a filter table may be changed. In the image processing systems 10A-10D of an embodiment mentioned above, although 5x5 regions and 3x3 regions are extracted from the data of a digital image, an extraction region may be changed suitably. It may differ in Embodiment 1 mentioned above, it may replace with the standard deviation sigma of a noise, and the noise decision value epsilon may be set up using other deviations, such as an average deviation.

[0118]

The means for solving a technical problem in a background art is listed below by technical idea of the present invention.

(Additional remark 1) In the image processing system which reduces the noise contained in the aforementioned noticed picture element while making the peripheral pixel which is placed at the circumference of a noticed picture element reflect,

The selection part which selects the pixel width permitted to the aforementioned true value as a pixel value of the aforementioned noticed picture element according to the true value of the aforementioned noticed picture element,

The correction part which extracts inner either or both sides of the pixel value of the aforementioned peripheral pixel, and the pixel value of the aforementioned noticed picture element as correction value which corrects the pixel value of the aforementioned noticed picture element according to the aforementioned pixel width selected by the aforementioned selection

part,

An image processing system characterized by preparation *****.

(Additional remark 2) In the image processing system which reduces the noise contained in the aforementioned noticed picture element while making the peripheral pixel which is placed at the circumference of a noticed picture element reflect,

The selection part which selects the pixel width permitted to the aforementioned true value as a pixel value of the aforementioned noticed picture element according to the true value of the aforementioned noticed picture element,

epsilon filter which made the aforementioned pixel width selected by the aforementioned selection part the reference value in comparison with the difference value of the pixel value of the aforementioned peripheral pixel, and the pixel value of the aforementioned noticed picture element,

An image processing system characterized by preparation *****.

(Additional remark 3) Image processing system of the description to the additional remark 1 or the additional remark 2, wherein the aforementioned selection part defines the aforementioned pixel width based on the standard deviation in distribution of the pixel value of the aforementioned noticed picture element.

(Additional remark 4) Image processing system of the description to the additional remark 3, wherein the aforementioned selection part is provided with the look-up table in which the correspondency of the pixel value of the aforementioned noticed picture element and the aforementioned pixel width was stored.

(Additional remark 5) Image processing system of the description to the additional remark 3 characterized by computing the aforementioned pixel width by the approximate expression as which the aforementioned selection part expresses the correspondency of the pixel value of the aforementioned noticed picture element, and the aforementioned pixel width.

(Additional remark 6) The aforementioned correction part the aforementioned pixel width based on the comparison result in comparison with the difference value of the pixel value of the aforementioned peripheral pixel, and the pixel value of the aforementioned noticed picture element as the aforementioned correction value, An image processing system of the description to the additional remark 1 extracting inner either or both sides of the pixel value of the aforementioned peripheral pixel, and the pixel value of the aforementioned noticed picture element.

(Additional remark 7) Based on the aforementioned comparison result, on condition that it judged that the aforementioned difference value was below the aforementioned pixel width, the aforementioned correction part, An image processing system of the description to the additional remark 6 extracting the pixel value of the aforementioned peripheral pixel as the aforementioned correction value, and extracting the pixel value of the aforementioned noticed picture element as the aforementioned correction value based on the aforementioned comparison result on condition that it judged that the aforementioned difference value was larger than the aforementioned pixel width.

(Additional remark 8) The aforementioned correction part the aforementioned pixel width based on the comparison result in comparison with the difference value of the median value of all the pixel values of the pixel value of the aforementioned peripheral pixel, and the pixel value of the aforementioned noticed picture element, and the pixel value of the aforementioned noticed picture element as the aforementioned correction value, An image processing system of the description to the additional remark 1 extracting the aforementioned median value or the pixel

value of the aforementioned noticed picture element.

(Additional remark 9) Based on the aforementioned comparison result, on condition that it judged that the aforementioned difference value was below the aforementioned pixel width, the aforementioned correction part, An image processing system of the description to the additional remark 8 extracting the aforementioned median value as the aforementioned correction value, and extracting the pixel value of the aforementioned noticed picture element as the aforementioned correction value based on the aforementioned comparison result on condition that it judged that the aforementioned difference value was larger than the aforementioned pixel width.

(Additional remark 10) Image processing system of the description to the additional remark 7 provided with the smoothing filter which computes the pixel value of the aforementioned noticed picture element by carrying out the weighted mean of all the pixel values which consists of either of the pixel values of the aforementioned peripheral pixel and the pixel values of the aforementioned noticed picture element which were extracted by the aforementioned correction part, or both sides.

(Additional remark 11) A median value is selected from all the pixel values which consists of either of the pixel values of the aforementioned peripheral pixel and the pixel values of the aforementioned noticed picture element which were extracted by the aforementioned correction part, or both sides, An image processing system of the description to the additional remark 7 provided with the median filter which makes this median value the pixel value of the aforementioned noticed picture element.

(Additional remark 12) In the image processing method used for the image processing system which reduces the noise contained in the aforementioned noticed picture element while making the peripheral pixel which is placed at the circumference of a noticed picture element reflect, The selection step which selects the pixel width permitted to the aforementioned true value as a pixel value of the aforementioned noticed picture element according to the true value of the aforementioned noticed picture element,

The correction step which extracts inner either or both sides of the pixel value of the aforementioned peripheral pixel, and the pixel value of the aforementioned noticed picture element as correction value which corrects the pixel value of the aforementioned noticed picture element according to the aforementioned pixel width selected by the aforementioned selection step,

An image processing method characterized by preparation *****.

(Additional remark 13) In the image processing method used for the image processing system which reduces the noise contained in the aforementioned noticed picture element while making the peripheral pixel which is placed at the circumference of a noticed picture element reflect, The selection step which selects the pixel width permitted to the aforementioned true value as a pixel value of the aforementioned noticed picture element according to the true value of the aforementioned noticed picture element,

A comparison step [the difference value of the pixel value of the aforementioned peripheral pixel, and the pixel value of the aforementioned noticed picture element / width / aforementioned / which was selected by the aforementioned selection step / pixel],

An image processing method characterized by preparation *****.

(Additional remark 14) Image processing method of the description to the additional remark 12 or the additional remark 13, wherein the aforementioned selection step defines the aforementioned pixel width based on the standard deviation in distribution of the pixel value of

the aforementioned noticed picture element.

(Additional remark 15) Image processing method of the description to the additional remark 14, wherein the aforementioned selection step selects the aforementioned pixel width by the look-up table in which the correspondency of the pixel value of the aforementioned noticed picture element and the aforementioned pixel width was stored.

(Additional remark 16) Image processing method of the description to the additional remark 14, wherein the aforementioned selection step computes the aforementioned pixel width by the approximate expression showing the correspondency of the pixel value of the aforementioned noticed picture element, and the aforementioned pixel width.

(Additional remark 17) The aforementioned correction step the aforementioned pixel width based on the comparison result in comparison with the difference value of the pixel value of the aforementioned peripheral pixel, and the pixel value of the aforementioned noticed picture element as the aforementioned correction value, An image processing method of the description to the additional remark 12 extracting inner either or both sides of the pixel value of the aforementioned peripheral pixel, and the pixel value of the aforementioned noticed picture element.

(Additional remark 18) Based on the aforementioned comparison result, on condition that it judged that the aforementioned difference value was below the aforementioned pixel width, the aforementioned correction step, An image processing method of the description to the additional remark 17 extracting the pixel value of the aforementioned peripheral pixel as the aforementioned correction value, and extracting the pixel value of the aforementioned noticed picture element as the aforementioned correction value based on the aforementioned comparison result on condition that it judged that the aforementioned difference value was larger than the aforementioned pixel width.

(Additional remark 19) The aforementioned correction step the aforementioned pixel width based on the comparison result in comparison with the difference value of the median value of all the pixel values of the pixel value of the aforementioned peripheral pixel, and the pixel value of the aforementioned noticed picture element, and the pixel value of the aforementioned noticed picture element, An image processing method of the description to the additional remark 12 characterized by extracting the aforementioned median value or the pixel value of the aforementioned noticed picture element as the aforementioned correction value.

(Additional remark 20) Based on the aforementioned comparison result, on condition that it judged that the aforementioned difference value was below the aforementioned pixel width, the aforementioned correction step, An image processing method of the description to the additional remark 19 extracting the aforementioned median value as the aforementioned correction value, and extracting the pixel value of the aforementioned noticed picture element as the aforementioned correction value based on the aforementioned comparison result on condition that it judged that the aforementioned difference value was larger than the aforementioned pixel width.

[Brief Description of the Drawings]

[0119]

[Drawing 1]It is a schematic configuration diagram of the image processing system concerning Embodiment 1.

[Drawing 2]It is an approximate account figure of the extraction region in the digital image used for Embodiment 1.

[Drawing 3]It is a graph which shows change of the noise decision value over the pixel value of

a noticed picture element.

[Drawing 4] It is an approximate account figure of the filter table used for Embodiment 1.

[Drawing 5] It is a schematic configuration diagram of the image processing system concerning Embodiment 2.

[Drawing 6] It is an approximate account figure of the extraction region in the digital image used for Embodiment 2.

[Drawing 7] It is a schematic configuration diagram of the image processing system concerning Embodiment 3.

[Drawing 8] It is a schematic configuration diagram of the image processing system concerning Embodiment 4.

[Drawing 9] It is a graph which shows approximation change of the noise decision value over the pixel value of a noticed picture element.

[Drawing 10] It is a distribution curve of noise to pixel value of noticed picture element existence probability.

[Drawing 11] It is a graph which shows change of the standard deviation of the noise to the pixel value of a noticed picture element.

[Explanations of letters or numerals]

[0120]

10A-10D Image processing system

30 epsilon filter

P00-P21, and P23-P44 Pixel value of a peripheral pixel

P22 Pixel value of a noticed picture element

Q00-Q10, and Q12-Q22 Pixel value of a peripheral pixel

Q11 Pixel value of a noticed picture element

DESCRIPTION OF DRAWINGS

[Brief Description of the Drawings]

[0119]

[Drawing 1]It is a schematic configuration diagram of the image processing system concerning Embodiment 1.

[Drawing 2]It is an approximate account figure of the extraction region in the digital image used for Embodiment 1.

[Drawing 3]It is a graph which shows change of the noise decision value over the pixel value of a noticed picture element.

[Drawing 4]It is an approximate account figure of the filter table used for Embodiment 1.

[Drawing 5]It is a schematic configuration diagram of the image processing system concerning Embodiment 2.

[Drawing 6]It is an approximate account figure of the extraction region in the digital image used for Embodiment 2.

[Drawing 7]It is a schematic configuration diagram of the image processing system concerning Embodiment 3.

[Drawing 8]It is a schematic configuration diagram of the image processing system concerning Embodiment 4.

[Drawing 9]It is a graph which shows approximation change of the noise decision value over the pixel value of a noticed picture element.

[Drawing 10]It is a distribution curve of noise to pixel value of noticed picture element existence probability.

[Drawing 11]It is a graph which shows change of the standard deviation of the noise to the pixel value of a noticed picture element.

DRAWINGS

[Drawing 1]

実施形態1に係る画像処理装置の概略構成図

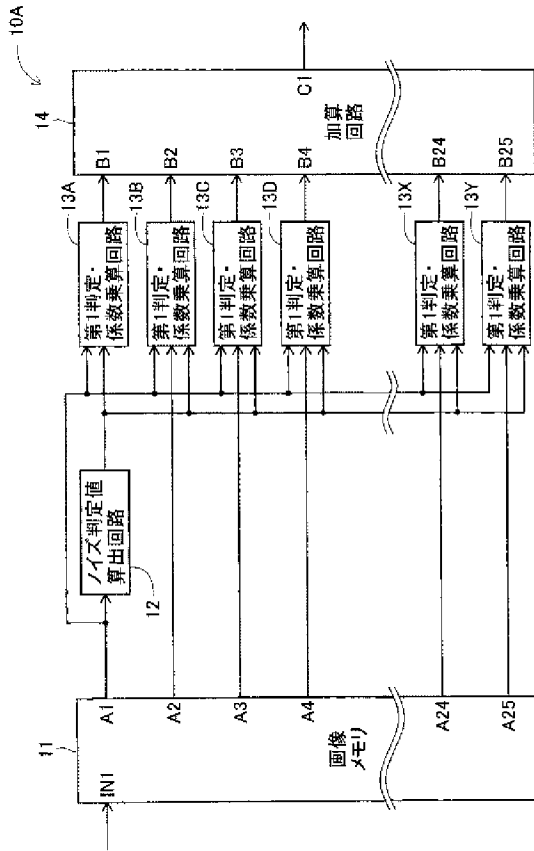

[Drawing 2]

実施形態1に用いられるデジタル画像中の抽出領域の概略説明図

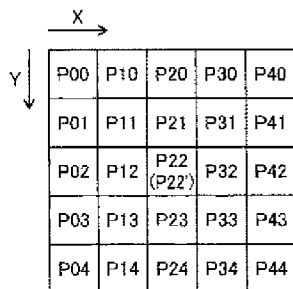

[Drawing 3]

注目画素の画素値に対するノイズ判定値の変化を示すグラフ

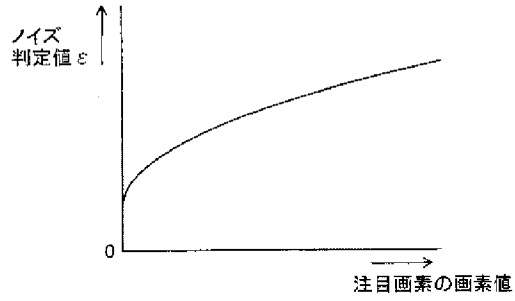

[Drawing 4]

実施形態1に用いられるフィルタテーブルの概略説明図

	x →				
y ↓	K00	K10	K20	K30	K40
	K01	K11	K21	K31	K41
	K02	K12	K22	K32	K42
	K03	K13	K23	K33	K43
	K04	K14	K24	K34	K44

[Drawing 5]

実施形態2に係る画像処理装置の概略構成図

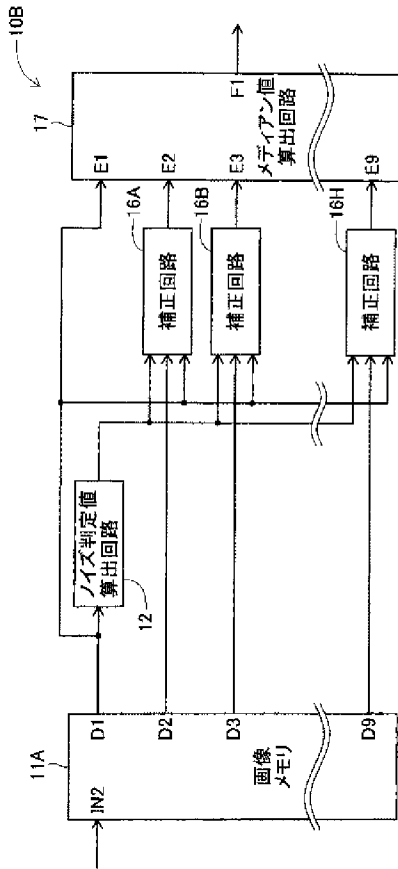

[Drawing 6]

実施形態2に用いられるデジタル画像中の抽出領域の概略説明図

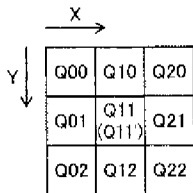

[Drawing 7]

実施形態3に係る画像処理装置の回路構成図

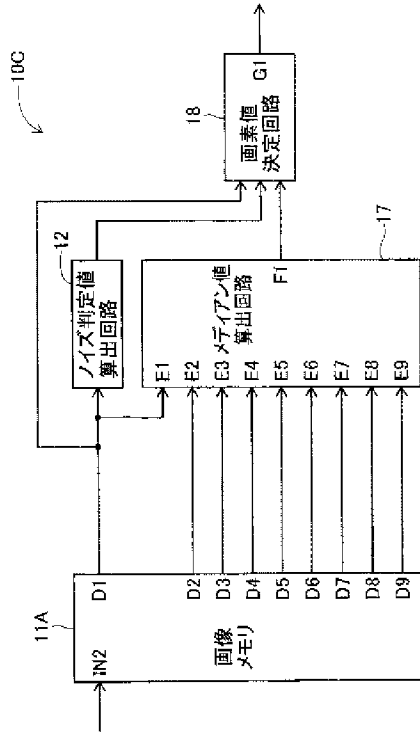

[Drawing 8]

実施形態4に係る画像処理装置の概略構成図

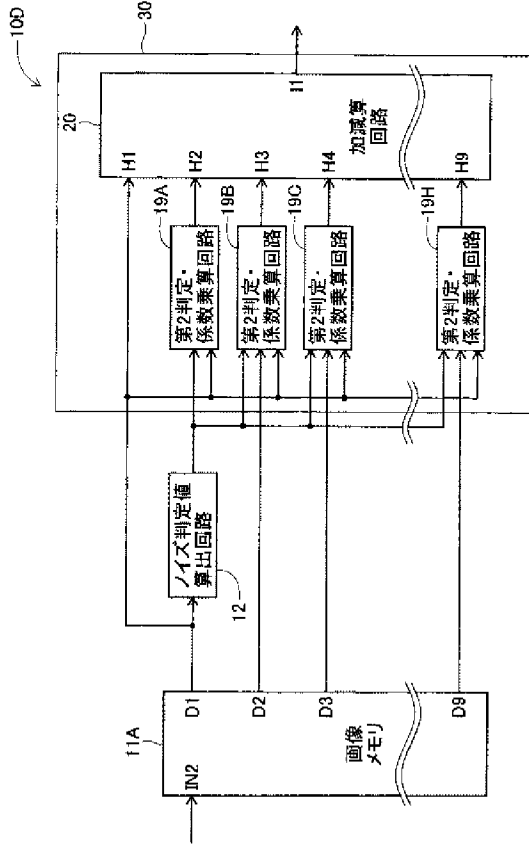

[Drawing 9]

注目画素の画素値に対するノイズ判定値の近似変化を示すグラフ

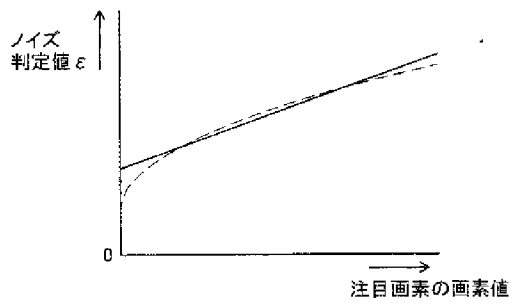

[Drawing 10]

注目画素の画素値に対するノイズの
存在確率の分布曲線

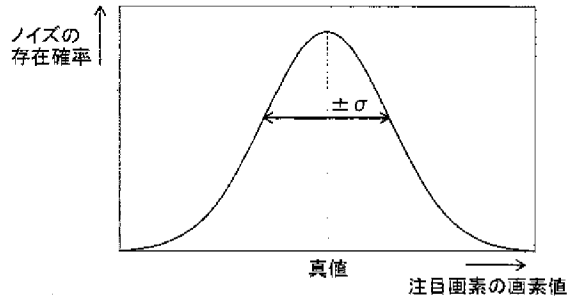

[Drawing 11]

注目画素の画素値に対するノイズの
標準偏差の変化を示すグラフ

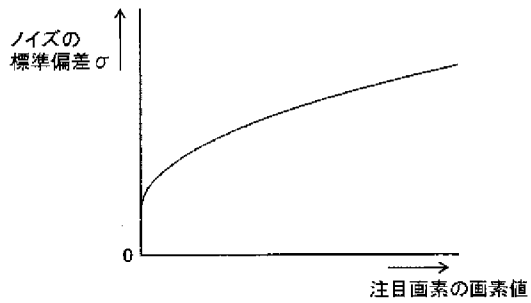

[Translation done.]

(19) 日本国特許庁(JP)

(12) 公開特許公報(A)

(11) 特許出願公開番号

特開2008-124976

(P2008-124976A)

(43) 公開日 平成20年5月29日(2008. 5. 29)

(51) Int.Cl.			F I			テーマコード (参考)		
HO4N	5/335	(2006.01)	HO4N	5/335	P	5B057		
GO6T	5/00	(2006.01)	GO6T	5/00	300	5C024		
HO4N	1/409	(2006.01)	HO4N	1/40	101C	5C077		
GO6T	5/20	(2006.01)	GO6T	5/20	C			

審査請求 未請求 請求項の数 10 O L (全 27 頁)

(21) 出願番号	特願2006-308997 (P2006-308997)	(71) 出願人	000005223 富士通株式会社
(22) 出願日	平成18年11月15日 (2006. 11. 15)		神奈川県川崎市中原区上小田中4丁目1番1号
		(74) 代理人	100117385 弁理士 田中 裕人
		(74) 代理人	100098431 弁理士 山中 郁生
		(72) 発明者	渡会 祐司 愛知県春日井市高蔵寺町二丁目1844番 2 富士通ヴィエルエスアイ株式会社内
		Fターム(参考)	5B057 CA08 CA12 CA16 CB08 CB12 CB16 CC02 CE02 CE05 CE06 CH09 CH11 CH18 DA17 DC23

最終頁に続く

(54) 【発明の名称】 画像処理装置及び画像処理方法

(57) 【要約】

【課題】 注目画素の画素値に対応させて、ノイズの軽減効果を発揮させることができる画像処理装置及び画像処理方法を提供する。

【解決手段】 注目画素の周囲に位置する周辺画素を反映させながら、注目画素に含まれるノイズを低減する画像処理装置10Aにおいて、注目画素の真値に応じ、注目画素の画素値として、真値に対して許容される画素幅を選定する選定部12と、選定部12によって選定された画素幅に応じ、注目画素の画素値を補正する補正值として、周辺画素の画素値と注目画素の画素値との内のいずれか一方又は双方を抽出する補正部13A~13Yと、を備える。

【選択図】 図1

実施形態1に係る画像処理装置の概略構成図

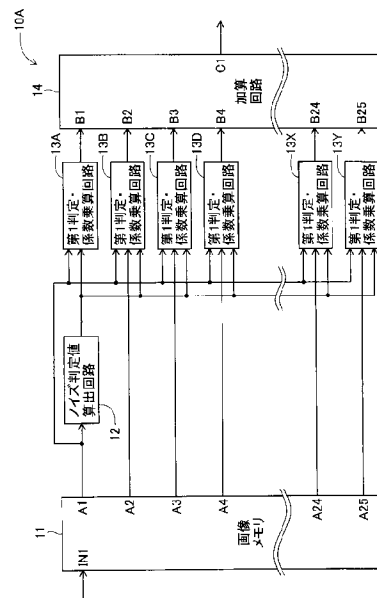

【特許請求の範囲】

【請求項 1】

注目画素の周囲に位置する周辺画素を反映させながら、前記注目画素に含まれるノイズを低減する画像処理装置において、

前記注目画素の真値に応じ、前記注目画素の画素値として、前記真値に対して許容される画素幅を選定する選定部と、

前記選定部によって選定された前記画素幅に応じ、前記注目画素の画素値を補正する補正值として、前記周辺画素の画素値と前記注目画素の画素値との内のいずれか一方又は双方を抽出する補正部と、

を備えることを特徴とする画像処理装置。

10

【請求項 2】

注目画素の周囲に位置する周辺画素を反映させながら、前記注目画素に含まれるノイズを低減する画像処理装置において、

前記注目画素の真値に応じ、前記注目画素の画素値として、前記真値に対して許容される画素幅を選定する選定部と、

前記選定部によって選定された前記画素幅を、前記周辺画素の画素値と前記注目画素の画素値との差分値と比較する基準値とした ε フィルタと、

を備えることを特徴とする画像処理装置。

【請求項 3】

前記選定部は、前記画素幅を、前記注目画素の画素値の分布における標準偏差に基づいて定めることを特徴とする請求項 1 又は請求項 2 に記載の画像処理装置。

20

【請求項 4】

前記補正部は、前記画素幅を、前記周辺画素の画素値と前記注目画素の画素値との差分値と比較した比較結果に基づいて、前記補正值として、前記周辺画素の画素値と前記注目画素の画素値との内のいずれか一方又は双方を抽出することを特徴とする請求項 1 に記載の画像処理装置。

【請求項 5】

前記補正部は、前記比較結果に基づいて、前記差分値が前記画素幅以下であると判断したことを条件に、前記補正值として前記周辺画素の画素値を抽出し、前記比較結果に基づいて、前記差分値が前記画素幅よりも大きいと判断したことを条件に、前記補正值として前記注目画素の画素値を抽出することを特徴とする請求項 4 に記載の画像処理装置。

30

【請求項 6】

前記補正部は、前記画素幅を、前記周辺画素の画素値及び前記注目画素の画素値のすべての画素値の内のメディアン値と前記注目画素の画素値との差分値と比較した比較結果に基づいて、前記補正值として、前記メディアン値あるいは前記注目画素の画素値を抽出することを特徴とする請求項 1 に記載の画像処理装置。

【請求項 7】

前記補正部は、前記比較結果に基づいて、前記差分値が前記画素幅以下であると判断したことを条件に、前記補正值として前記メディアン値を抽出し、前記比較結果に基づいて、前記差分値が前記画素幅よりも大きいと判断したことを条件に、前記補正值として前記注目画素の画素値を抽出することを特徴とする請求項 6 に記載の画像処理装置。

40

【請求項 8】

注目画素の周囲に位置する周辺画素を反映させながら、前記注目画素に含まれるノイズを低減する画像処理装置に用いられる画像処理方法において、

前記注目画素の真値に応じ、前記注目画素の画素値として、前記真値に対して許容される画素幅を選定する選定ステップと、

前記選定ステップによって選定された前記画素幅に応じ、前記注目画素の画素値を補正する補正值として、前記周辺画素の画素値と前記注目画素の画素値との内のいずれか一方又は双方を抽出する補正ステップと、

を備えることを特徴とする画像処理方法。

50

【請求項 9】

注目画素の周囲に位置する周辺画素を反映させながら、前記注目画素に含まれるノイズを低減する画像処理装置に用いられる画像処理方法において、

前記注目画素の真値に応じ、前記注目画素の画素値として、前記真値に対して許容される画素幅を選定する選定ステップと、

前記選定ステップによって選定された前記画素幅を、前記周辺画素の画素値と前記注目画素の画素値との差分値と比較する比較ステップと、

を備えることを特徴とする画像処理方法。

【請求項 10】

前記選定ステップは、前記画素幅を、前記注目画素の画素値の分布における標準偏差に基づいて定めることを特徴とする請求項 8 又は請求項 9 に記載の画像処理方法。 10

【発明の詳細な説明】

【技術分野】

【0001】

この発明は、画像処理装置及び画像処理方法に関する。

【背景技術】

【0002】

例えば、デジタルカメラは、撮像素子によって撮影した画像を、デジタル画像に変換する。近年のデジタルカメラにおいては、撮像素子の光検出能力が向上していることから、被写体からの光に加え、ランダムノイズ等をも検出し易くなり、S/N比が低下している。そこで、近年のデジタルカメラにおいては、撮影した画像の画質を低下させないようにしながら、ランダムノイズ等を低減し、S/N比を改善させることが求められている。 20

【0003】

一般に、ランダムノイズ等を低減し、S/N比を改善させる画像処理装置として、重みテーブルを備えた空間フィルタ、メディアンフィルタを用いたものがそれぞれ知られている。例えば、非特許文献 1 に開示されているように、上記の空間フィルタは、デジタル画像内の 3×3 領域の画素値と 3×3 領域の重みテーブルとの積和演算を、デジタル画像の全域に亘って順次行い、それぞれの積和演算の結果の平均値を順次算出している。そして、上記の空間フィルタにおいては、算出した各平均値を、3×3 領域の注目画素の画素値とし、デジタル画像の全域に亘って算出された各平均値により、デジタル画像が補正される。そこで、上記の空間フィルタにおいては、各平均値によって、デジタル画像が補正されるため、補正前のデジタル画像に混入したランダムノイズが平滑化される。このため、上記の空間フィルタにおいては、補正前のデジタル画像に混入したランダムノイズが低減され、S/N比を改善することができる。 30

【0004】

また、例えば、非特許文献 2 に開示されているように、上記のメディアンフィルタにおいては、デジタル画像内の 3×3 領域のすべての画像値を、値が大きいものから順番に並べ替え、3×3 領域の注目画素の画素値として、並べ変えた値の内のメディアン値（中間値）を求めている。そして、このメディアンフィルタにおいては、デジタル画像の全域に亘ってメディアン値を求め、各メディアン値によって、デジタル画像が補正される。そこで、このメディアンフィルタにおいては、各メディアン値によって、デジタル画像が補正されるため、並べ変えた値の内の最大値によって、デジタル画像が形成される場合に比べて、デジタル画像に混入したノイズが抑えられる。このため、このメディアンフィルタにおいては、メディアン値によって、デジタル画像を補正することにより、S/N比を改善することができる。 40

【0005】

さらに、S/N比を改善させる画像処理装置として、εフィルタを用いたものが知られている（非特許文献 3 参照。）。εフィルタは、信号における突発的大振幅変化成分を維持しながら、信号に加えられた小振幅ランダムノイズを取り除く特性を有している。そこ 50

で、 ε フィルタにおいては、例えば、被写体からの光の信号に加えられたランダムノイズを取り除くことができ、 S/N 比を改善することができる。

【非特許文献1】田中弘著、「画像処理応用技術」、第3版、株式会社工業調査会、1991年6月、p. 57-58

【非特許文献2】貴家仁志著、「よくわかるデジタル画像技術」、初版、CQ出版株式会社、1996年2月、p. 102

【非特許文献3】原島 博、外3名「 ε -分離非線形デジタルフィルタとその応用」、1982年、信学論、vol. J65-A、no. 4、p297-304

【発明の開示】

【発明が解決しようとする課題】

10

【0006】

しかしながら、上述した空間フィルタを用いた画像処理装置においては、注目画素の画素値を算出する際に、過度にノイズが混入した画素値が用いられて、積和演算の平均値が算出されるおそれがある。また、上述したメディアンフィルタを用いた画像処理装置においても、注目画素の画素値を求める際に、過度にノイズが混入した画素値が用いられて、メディアン値が求められるおそれがある。このような場合には、過度にノイズが混入した画素値の影響を受けて、注目画素の画素値が、注目画素の真値に近づくことが妨げられる。そこで、上述した画像処理装置においては、ノイズの低減効果が十分ではなく、デジタル画像が不鮮明になるおそれがある。

【0007】

20

さらに、図10に図示するように、デジタル画像に混入するノイズの分布は、注目画素の真値に対する存在確率が最大となる正規分布を示す。また、図11に図示するように、注目画素の画素値が大きくなるにつれて、ノイズの標準偏差 σ は増加する。

【0008】

しかしながら、上述した ε フィルタを用いる画像処理装置においては、注目画素の画素値によってノイズの標準偏差 σ が変化してしまうことが考慮されておらず、ノイズ判定値を一定の値に設定し、ランダムノイズを取り除いていた。そこで、注目画素の画素値が小さい領域では、画素値が大きい領域に比べると、ノイズ判定値によって定められる閾値が、最適な値よりも高い値に設定されてしまう。このため、ノイズに加えて、デジタル画像の補正が過剰となり、デジタル画像の濃度が低下してしまうおそれがある。

30

【0009】

加えて、注目画素の画素値が大きい領域では、画素値が小さい領域に比べると、ノイズ判定値によって定められる閾値が、最適な値よりも低い値に設定されてしまう。このため、十分にノイズを取り除くことができず、デジタル画像が不鮮明になるおそれがあった。

【0010】

この発明は、このような状況に鑑み提案されたものであって、注目画素の画素値に対応させて、ノイズの軽減効果を発揮させることができる画像処理装置及び画像処理方法を提供することを目的とする。

【課題を解決するための手段】

40

【0011】

請求項1の発明に係る画像処理装置は、注目画素の周囲に位置する周辺画素を反映させながら、前記注目画素に含まれるノイズを低減する画像処理装置において、前記注目画素の真値に応じ、前記注目画素の画素値として、前記真値に対して許容される画素幅を選定する選定部と、前記選定部によって選定された前記画素幅に応じ、前記注目画素の画素値を補正する補正值として、前記周辺画素の画素値と前記注目画素の画素値との内のいずれか一方又は双方を抽出する補正部と、を備えることを特徴とする。

【0012】

請求項1の発明に係る画像処理装置によれば、選定部が、注目画素の真値に応じ、注目画素の画素値として、真値に対して許容される画素幅を選定すると、選定される画素幅を

50

、注目画素の真値に応じて変化させることができる。

また、請求項 1 の発明によれば、選定部によって選定された画素幅に応じ、補正部が、注目画素の画素値を補正する補正值として、周辺画素の画素値と注目画素の画素値との内のいずれか一方又は双方を抽出する。そこで、補正部は、画素幅に応じて、抽出される補正值を変化させることができる。したがって、請求項 1 の発明に係る画像処理装置によれば、補正部によって抽出された補正值により、注目画素の画素値を補正して、該注目画素の画素値を、ノイズを低減させたものにすることができる。

【0013】

請求項 8 の発明に係る画像処理方法は、注目画素の周囲に位置する周辺画素を反映させながら、前記注目画素に含まれるノイズを低減する画像処理装置に用いられる画像処理方法において、前記注目画素の真値に応じ、前記注目画素の画素値として、前記真値に対して許容される画素幅を選定する選定ステップと、前記選定ステップによって選定された前記画素幅に応じ、前記注目画素の画素値を補正する補正值として、前記周辺画素の画素値と前記注目画素の画素値との内のいずれか一方又は双方を抽出する補正ステップと、を備えることを特徴とする。

10

【0014】

請求項 8 の発明に係る画像処理方法によれば、選定ステップが、注目画素の真値に応じ、注目画素の画素値として、真値に対して許容される画素幅を選定すると、選定される画素幅を、注目画素の真値に応じて変化させることができる。

また、請求項 8 の発明によれば、選定ステップによって選定された画素幅に応じ、補正ステップが、注目画素の画素値を補正する補正值として、周辺画素の画素値と注目画素の画素値との内のいずれか一方又は双方を抽出する。そこで、補正ステップは、画素幅に応じて、抽出される補正值を変化させることができる。したがって、請求項 8 の発明に係る画像処理方法によれば、補正ステップによって抽出された補正值により、注目画素の画素値を補正して、該注目画素の画素値を、ノイズを低減させたものにすることができる。

20

【発明の効果】

【0015】

本発明の画像処理装置及び画像処理方法によれば、注目画素の真値に応じ、注目画素の画素値として、真値に対して許容される画素幅を選定すると、選定される画素幅を、注目画素の真値に応じて変化させることができる。

30

また、本発明によれば、選定された画素幅に応じ、注目画素の画素値を補正する補正值として、周辺画素の画素値と注目画素の画素値との内のいずれか一方又は双方を抽出する。そこで、画素幅に応じて、抽出される補正值を変化させることができる。したがって、本発明によれば、抽出された補正值により、注目画素の画素値を補正して、該注目画素の画素値を、ノイズを低減させたものにすることができる。

【発明を実施するための最良の形態】

【0016】

<実施形態 1 >

本発明の実施形態 1 を、図 1 ないし図 4 を参照しつつ説明する。ここでは、本発明の画像処理装置を、デジタルカメラに搭載された画像処理装置 10A を例に挙げて説明する。図 1 は、実施形態 1 の画像処理装置 10A の構成を示すブロック図である。画像処理装置 10A は、図示するように、画像メモリ 11 と、ノイズ判定値算出回路 12 と、第 1 判定・係数乗算回路 13A ~ 13Y と、加算回路 14 とを備えている。

40

【0017】

画像メモリ 11 は、SRAM と FF とによって構成されている。なお、図示しないが、画像メモリ 11 の入力端子 IN1 には、イメージセンサの信号を処理する信号変換部の出力が接続されている。

【0018】

ノイズ判定値算出回路 12 の入力端子は、画像メモリ 11 の注目画素値出力端子 A1 に接続されている。実施形態 1 では、ノイズ判定値算出回路 12 は、ルックアップテーブル

50

メモリによって構成されている。

【0019】

第1判定・係数乗算回路13Aの第1入力端子は、画像メモリ11の注目画素値出力端子A1に接続されている。第1判定・係数乗算回路13Aの第2入力端子は、ノイズ判定値算出回路12の出力端子に接続されている。

【0020】

第1判定・係数乗算回路13Bの第1入力端子は、画像メモリ11の注目画素値出力端子A1に接続されている。第1判定・係数乗算回路13Bの第2入力端子は、画像メモリ11の周辺画素値出力端子A2に接続されている。さらに、第1判定・係数乗算回路13Bの第3入力端子は、ノイズ判定値算出回路12の出力端子に接続されている。

10

【0021】

また、第1判定・係数乗算回路13C～13Yの各第1入力端子は、第1判定・係数乗算回路13Bの第1入力端子と同様に、画像メモリ11の注目画素値出力端子A1に接続されている。第1判定・係数乗算回路13C～13Yの各第2入力端子は、画像メモリ11の各周辺画素値出力端子A3～A25にそれぞれ接続されている。さらに、第1判定・係数乗算回路13C～13Yの各第3入力端子は、ノイズ判定値算出回路12の出力端子に接続されている。

【0022】

加算回路14の入力端子B1は、第1判定・係数乗算回路13Aの出力端子に接続されている。加算回路14の各入力端子B2～B25は、第1判定・係数乗算回路13B～13Yの各出力端子にそれぞれ接続されている。なお、図中の符号C1は、加算回路14の出力端子である。

20

【0023】

次に、実施形態1の画像処理装置10Aの画像処理方法について説明する。上述したように、画像メモリ11の入力端子IN1には、イメージセンサの信号を処理する信号変換部の出力が接続されている。そして、デジタル信号は、前記入力端子IN1を介し、画像メモリ11に入力される。

【0024】

画像メモリ11は、イメージセンサの信号を処理する信号変換部によって生成された輝度成分のラインデータを記憶する。ラインデータは、複数の画素値によって構成されている。画像メモリ11は、ラインデータ毎に、被写体のデジタル画像のデータを記憶する。

30

【0025】

本実施形態の画像処理装置10Aにおいては、図2に図示するように、画像メモリ11が、画像メモリ11に記憶されたデジタル画像のデータから、X方向及びY方向にそれぞれ5画素ずつの5×5領域を抽出する。図中のP22は注目画素値データを示し、P22以外の全符号P00～P44は周辺画素値データを示す。本実施形態では、注目画素値データP22からノイズデータを削除したものが、本発明の注目画素の真値に相当する。

【0026】

さらに、画像処理装置10Aにおいては、画像メモリ11が、注目画素値出力端子A1から、注目画素値データP22を、ノイズ判定値算出回路12及び各第1判定・係数乗算回路13A～13Yに出力する。加えて、画像メモリ11は、CPUによって制御され、各周辺画素値出力端子A2～A25から、周辺画素値データP00等を、各第1判定・係数乗算回路13B～13Yにそれぞれ出力する。

40

【0027】

ノイズ判定値算出回路12には、画像メモリ11によって出力された注目画素値データP22に対応するノイズ判定値 ε が、ルックアップテーブルとして記憶されている。ノイズ判定値算出回路12は、前記注目画素値データP22に応じ、ルックアップテーブルからノイズ判定値 ε を読み出し、該ノイズ判定値 ε を、各第1判定・係数乗算回路13A～13Yに出力する。なお、ここでは、ノイズ判定値 ε が、 $\pm 3\sigma$ に設定されている。図3

50

に図示するように、注目画素の画素値（P 2 2）が大きくなるにつれて、ノイズ判定値 ε は増加する。なお、 σ は、ノイズの標準偏差である。

【0028】

上述したように、第1判定・係数乗算回路13Aには、注目画素値データP 2 2及びノイズ判定値 ε のデータが入力されている。また、各第1判定・係数乗算回路13B～13Yには、注目画素値データP 2 2、周辺画素値データP 0 0等及びノイズ判定値 ε のデータがそれぞれ入力されている。

【0029】

第1判定・係数乗算回路13Aは、最初に、注目画素の画素値（P 2 2）から注目画素の画素値（P 2 2）を減算する。次に、第1判定・係数乗算回路13Aは、減算結果の絶対値を、ノイズ判定値 ε と比較する。第1判定・係数乗算回路13Aは、前記絶対値が、ノイズ判定値 ε 以下であると判断し、注目画素の画素値を選択する。

10

【0030】

続いて、第1判定・係数乗算回路13Aは、注目画素の画素値に対するフィルタ係数K 2 2（図4参照。）を、注目画素の画素値に乗算する。その後、第1判定・係数乗算回路13Aは、乗算結果の値を加算回路14の入力端子B 1に出力する。なお、第1判定・係数乗算回路13Aは、図4に図示するように、注目画素の画素値（P 2 2）に対応するフィルタ係数K 2 2及び周辺画素の画素値（P 2 2を除くP 0 0～P 4 4）に対応するフィルタ係数（K 2 2を除くK 0 0～K 4 4）を、フィルタテーブルとして記憶している。本実施形態では、各フィルタ係数が、 $1/25$ に設定され、各フィルタ係数の重み付けは同

20

【0031】

第1判定・係数乗算回路13Bは、最初に、周辺画素の画素値（P 0 0）から注目画素の画素値（P 2 2）を減算する。次に、第1判定・係数乗算回路13Bは、減算結果の絶対値を、前記ノイズ判定値 ε と比較する。第1判定・係数乗算回路13Bは、前記絶対値がノイズ判定値 ε 以下であると判断すると、周辺画素の画素値（P 0 0）を選択する。第1判定・係数乗算回路13Bは、前記絶対値がノイズ判定値 ε 以下であると判断することにより、周辺画素の画素値（P 0 0）が、注目画素の画素値（P 2 2）に対して許容される値であることを判定している。したがって、ノイズ判定値 ε は、注目画素の画素値に対して許容される画素幅を意味する。

30

【0032】

続いて、第1判定・係数乗算回路13Bは、周辺画素の画素値（P 0 0）に対するフィルタ係数K 0 0（図4参照。）を、周辺画素の画素値（P 0 0）に乗算する。その後、第1判定・係数乗算回路13Bは、乗算結果の値を加算回路14の入力端子B 2に出力する。

【0033】

一方、第1判定・係数乗算回路13Bは、前記絶対値がノイズ判定値 ε よりも大きいと判断すると、注目画素の画素値（P 2 2）を選択する。続いて、第1判定・係数乗算回路13Bは、注目画素の画素値（P 2 2）に対応するフィルタ係数K 2 2を、注目画素の画素値（P 2 2）に乗算する。その後、第1判定・係数乗算回路13Bは、乗算結果の値を加算回路14の入力端子B 2に出力する。

40

【0034】

各第1判定・係数乗算回路13C～13Yは、上述した第1判定・係数乗算回路13Bと同様に、周辺画素の画素値（P 0 0及びP 2 2を除くP 1 0～P 4 4）から注目画素の画素値（P 2 2）をそれぞれ減算する。次に、第1判定・係数乗算回路13C～13Yは、減算した結果の絶対値を、前記ノイズ判定値 ε とそれぞれ比較する。各第1判定・係数乗算回路13C～13Yは、各絶対値がノイズ判定値 ε 以下であると判断すると、周辺画素の画素値（前記P 1 0～P 4 4）をそれぞれ選択する。

【0035】

続いて、各第1判定・係数乗算回路13C～13Yは、周辺画素の画素値（前記P 1 0

50

～P 4 4) に対応するフィルタ係数 $K 1 0 \sim K 4 4$ (図 4 参照。) を、周辺画素の画素値 (前記 P 1 0 ～ P 4 4) にそれぞれ乗算する。その後、各第 1 判定・係数乗算回路 1 3 C ～ 1 3 Y は、乗算結果の値を加算回路 1 4 の各入力端子 B 3 ～ B 2 5 にそれぞれ出力する。

【0 0 3 6】

一方、各第 1 判定・係数乗算回路 1 3 C ～ 1 3 Y は、前記絶対値がノイズ判定値 ε よりも大きいと判断すると、注目画素の画素値 (P 2 2) をそれぞれ選択する。続いて、各第 1 判定・係数乗算回路 1 3 C ～ 1 3 Y は、注目画素の画素値 (P 2 2) に対応するフィルタ係数 $K 2 2$ を、注目画素の画素値 (P 2 2) にそれぞれ乗算する。その後、各第 1 判定・係数乗算回路 1 3 C ～ 1 3 Y は、乗算結果の値を加算回路 1 4 の入力端子 B 3 ～ B 2 5 にそれぞれ出力する。

10

【0 0 3 7】

加算回路 1 4 は、各入力端子 B 1 ～ B 2 5 を介して入力されたすべての乗算結果の値を、加算する。加算された値は、前記デジタル画像に混入したノイズを低減した注目画素の画素値 (P 2 2')、図 2 参照。) となる。加算回路 1 4 は、出力端子 C 1 から、注目画素値データ P 2 2' を出力する。

【0 0 3 8】

加算回路 1 4 は、前記デジタル画像の全域に亘って 5×5 領域をそれぞれ抽出し、上述した注目画素の画素値 (P 2 2') を算出する。加算回路 1 4 は、算出した注目画素の画素値 (P 2 2') のデータを、出力端子 C 1 から順次出力する。本実施形態の画像処理装置 1 0 A では、前記注目画素の画素値 (P 2 2') を用いて、前記デジタル画像を復元し、S/N 比を改善している。なお、本実施形態では、各第 1 判定・係数乗算回路 1 3 A ～ 1 3 Y 及び加算回路 1 4 は、空間フィルタを構成する。各第 1 判定・係数乗算回路 1 3 A ～ 1 3 Y 及び加算回路 1 4 は、同じ重み付けがされた各フィルタ係数と前記デジタル画像の全 5×5 領域の各画素値との積和演算により、注目画素の画素値 (P 2 2') を順次算出している。そこで、各第 1 判定・係数乗算回路 1 3 A ～ 1 3 Y は、各フィルタ係数の重み付けを同じにすることにより、積和演算結果を、すべての画素値を重み付け平均したものにすることができから、本発明の平滑化フィルタに相当する。

20

【0 0 3 9】

本実施形態においては、ノイズ判定値算出回路 1 2 は、ルックアップテーブルによって、注目画素の画素値 (P 2 2) に対して許容される画素幅 (ノイズ判定値 ε) を読み出して選定している。したがって、ノイズ判定値 ε を選定するノイズ判定値算出回路 1 2 は、本発明の選定部に相当する。また、本実施形態では、ルックアップテーブルを用い、注目画素の画素値 (P 2 2) に対して許容される画素幅 (ノイズ判定値 ε) を読み出して選定することが、本発明の選定ステップに相当する。

30

【0 0 4 0】

また、本実施形態においては、第 1 判定・係数乗算回路 1 3 A ～ 1 3 Y は、ノイズ判定値算出回路 1 2 によって入力されたノイズ判定値 ε を、前記絶対値と比較している。その後、上述したように、ノイズ判定値 ε と前記絶対値との比較結果に基づいて、第 1 判定・係数乗算回路 1 3 A ～ 1 3 Y は、被写体のデジタル画像に混入したノイズを低減し、該デジタル画像を復元する注目画素の画素値 (P 2 2') の算出に用いられ、かつ、フィルタ係数と乗算される注目画素の画素値 (P 2 2)、周辺画素の画素値 (P 2 2 を除く P 0 0 ～ P 4 4) をそれぞれ選択している。このように、第 1 判定・係数乗算回路 1 3 A ～ 1 3 Y は、ノイズを低減して、デジタル画像の復元に用いられる周辺画素の画素値や注目画素の画素値を選択しているから、本発明の補正部に相当する。なお、本実施形態では、周辺画素の画素値 (P 2 2 を除く P 0 0 ～ P 4 4) 及び注目画素の画素値 (P 2 2) は、本発明の補正值に相当する。

40

【0 0 4 1】

本実施形態では、ルックアップテーブルを用いて選定されたノイズ判定値 ε と前記絶対値との比較結果に基づいて、注目画素の画素値 (P 2 2)、周辺画素の画素値 (P 2 2 を

50

除く P 0 0 ~ P 4 4) をそれぞれ選択することが、本発明の補正ステップに相当する。

【 0 0 4 2 】

<実施形態 1 の効果>

上述した実施形態 1 の画像処理装置 1 0 A においては、ノイズ判定値算出回路 1 2 が、注目画素の画素値 (P 2 2) に応じて、ノイズ判定値 ε を読み出して選定している。そこで、実施形態 1 の画像処理装置 1 0 A では、注目画素の画素値 (P 2 2) に応じて、選定するノイズ判定値 ε を変化させることができる。

また、本実施形態の画像処理装置 1 0 A によれば、ノイズ判定値算出回路 1 2 によって選定されたノイズ判定値 ε に応じ、各第 1 判定・係数乗算回路 1 3 A ~ 1 3 Y が、各 5×5 領域の画素値に混入したノイズを低減させる補正值として、周辺画素の画素値 (P 2 2 を除く P 0 0 ~ P 4 4) と注目画素の画素値 (P 2 2) との内のいずれか一方又は双方を選択している。そこで、各第 1 判定・係数乗算回路 1 3 A ~ 1 3 Y は、ノイズ判定値 ε に応じて、選定する補正值を変化させることができる。したがって、本実施形態の画像処理装置 1 0 A によれば、各第 1 判定・係数乗算回路 1 3 A ~ 1 3 Y によって選定された補正值により、各 5×5 領域の注目画素の画素値を補正して、補正後の注目画素の画素値を、ノイズを低減させたものにするすることができる。

10

【 0 0 4 3 】

さらに、実施形態 1 の画像処理装置 1 0 A に用いられる画像処理方法によれば、注目画素値の画素値 (P 2 2) に応じて、ノイズ判定値 ε を読み出して選定している。そこで、実施形態 1 の画像処理方法によれば、注目画素の画素値 (P 2 2) に応じて、選定するノイズ判定値 ε を変化させることができる。

20

また、本実施形態の画像処理装置 1 0 A に用いられる画像処理方法によれば、選定されたノイズ判定値 ε に応じ、各 5×5 領域の画素値に混入したノイズを低減させる補正值として、周辺画素の画素値 (P 2 2 を除く P 0 0 ~ P 4 4) と注目画素の画素値 (P 2 2) との内のいずれか一方又は双方を選択している。そこで、本実施形態の画像処理方法においては、ノイズ判定値 ε に応じて、選定する補正值を変化させることができる。したがって、本実施形態の画像処理方法によれば、選定された補正值により、各 5×5 領域の注目画素の画素値を補正して、補正後の注目画素の画素値を、ノイズを低減させたものにするすることができる。

30

【 0 0 4 4 】

本実施形態の画像処理装置 1 0 A においては、各第 1 判定・係数乗算回路 1 3 A ~ 1 3 Y が、注目画素の画素値の分布における標準偏差 σ に基づいて、ノイズ判定値 ε の値を、 $\pm 3 \sigma$ に設定している。そこで、本実施形態の画像処理装置 1 0 A によれば、各第 1 判定・係数乗算回路 1 3 A ~ 1 3 Y が、ノイズ判定値 ε を 3σ に設定することにより、ノイズ判定値 ε の値を、注目画素の真値を中心とした注目画素の画素値のほぼ全体を含む値に設定することができる。

さらに、本実施形態の画像処理装置 1 0 A に用いられる画像処理方法によれば、注目画素の画素値の分布における標準偏差 σ に基づいて、ノイズ判定値 ε の値を、 $\pm 3 \sigma$ に設定している。そこで、本実施形態の画像処理方法によれば、ノイズ判定値 ε を 3σ に設定することにより、ノイズ判定値 ε の値を、注目画素の真値を中心とした注目画素の画素値のほぼ全体を含む値に設定することができる。

40

【 0 0 4 5 】

本実施形態の画像処理装置 1 0 A においては、ノイズ判定値算出回路 1 2 には、注目画素の画素値 (P 2 2) に対応するノイズ判定値 ε が、ルックアップテーブルとして記憶されている。そこで、ノイズ判定値算出回路 1 2 は、注目画素の画素値 (P 2 2) とノイズ判定値 ε との対応関係を参照することにより、注目画素の画素値 (P 2 2) に対するノイズ判定値 ε を容易に選定することができる。

さらに、本実施形態の画像処理装置 1 0 A に用いられる画像処理方法によれば、注目画素の画素値 (P 2 2) とノイズ判定値 ε との対応関係が格納されたルックアップテーブルによって、ノイズ判定値 ε を選定している。そこで、本実施形態の画像処理方法によれば

50

、注目画素の画素値（P 2 2）とノイズ判定値 ε との対応関係を参照することにより、注目画素の画素値（P 2 2）に対するノイズ判定値 ε を容易に選定することができる。

【0046】

本実施形態の画像処理装置10Aにおいては、ノイズ判定値 ε を、周辺画素の画素値（P 2 2を除くP 0 0～P 4 4）から注目画素の画素値（P 2 2）を減算した結果の絶対値と比較した結果に基づいて、各第1判定・係数乗算回路13B～13Yが、前記補正值として、周辺画素の画素値と注目画素の画素値との内のいずれか一方又は双方をそれぞれ選択する。そこで、ノイズ判定値 ε を、前記絶対値と比較した結果に基づいて、各第1判定・係数乗算回路13B～13Yは、選択する補正值を変化させることができる。

さらに、本実施形態の画像処理装置10Aに用いられる画像処理方法によれば、ノイズ判定値 ε を、周辺画素の画素値（P 2 2を除くP 0 0～P 4 4）から注目画素の画素値（P 2 2）を減算した結果の絶対値と比較した結果に基づき、前記補正值として、周辺画素の画素値と注目画素の画素値との内のいずれか一方又は双方を選択する。そこで、本実施形態の画像処理方法によれば、ノイズ判定値 ε を、前記絶対値と比較した結果に基づいて、選択する補正值を変化させることができる。

【0047】

本実施形態の画像処理装置10Aにおいては、各第1判定・係数乗算回路13B～13Yによって、周辺画素の画素値（P 2 2を除くP 0 1～P 4 4）から注目画素の画素値（P 2 2）を減算した結果の絶対値が、ノイズ判定値 ε 以下であると判断したことを条件に、前記補正值として、周辺画素の画素値（P 2 2を除くP 0 1～P 4 4）をそれぞれ選択する。そこで、各第1判定・係数乗算回路13B～13Yによって選択された各周辺画素の画素値は、注目画素の画素値に過度にノイズが混入されたものではなく、補正值にノイズが混入することを抑えることができる。

また、本実施形態の画像処理装置10Aによれば、各第1判定・係数乗算回路13B～13Yによって、周辺画素の画素値（P 2 2を除くP 0 1～P 4 4）から注目画素の画素値（P 2 2）を減算した結果の絶対値が、ノイズ判定値 ε よりも大きいと判断したことを条件に、前記補正值として、注目画素の画素値（P 2 2）をそれぞれ選択する。そこで、各第1判定・係数乗算回路13B～13Yは、補正值として、過度にノイズが混入した周辺画素の画素値を選択することがなく、補正值にノイズが混入することを抑えることができる。

【0048】

さらに、本実施形態の画像処理装置10Aに用いられる画像処理方法によれば、周辺画素の画素値（P 2 2を除くP 0 1～P 4 4）から注目画素の画素値（P 2 2）を減算した結果の絶対値が、ノイズ判定値 ε 以下であると判断したことを条件に、前記補正值として、周辺画素の画素値（P 2 2を除くP 0 1～P 4 4）をそれぞれ選択する。そこで、選択された各周辺画素の画素値は、注目画素の画素値に過度にノイズが混入されたものではなく、補正值にノイズが混入することを抑えることができる。

また、本実施形態の画像処理方法によれば、周辺画素の画素値（P 2 2を除くP 0 1～P 4 4）から注目画素の画素値（P 2 2）を減算した結果の絶対値が、ノイズ判定値 ε よりも大きいと判断したことを条件に、前記補正值として、注目画素の画素値（P 2 2）をそれぞれ選択する。そこで、補正值として、過度にノイズが混入された周辺画素の画素値を選択することがなく、補正值にノイズが混入することを抑えることができる。

【0049】

本実施形態では、各第1判定・係数乗算回路13A～13Yが、該第1判定・係数乗算回路13A～13Yによって選択された周辺画素の画素値（P 2 2を除くP 0 0～P 4 4）と注目画素の画素値（P 2 2）との内のいずれか一方又は双方からなるすべての画素値に、同一の重み付けがされたフィルタ係数を乗算している。その後、加算回路14は、すべての乗算結果の値を加算することにより、各5×5領域の画素値の平均値を順次算出し、前記平均値を、各5×5領域の注目画素の画素値（P 2 2'）としている。そこで、本実施形態の画像処理装置10Aによれば、各5×5領域の画素値の平均値を順次算出する

ことにより、ノイズが混入した周辺画素の画素値が突出することを防ぎ、補正された注目画素の画素値（ P_{22} ）を算出することができる。したがって、補正された注目画素の画素値（ P_{22} ）が、ノイズを低減させたものになる。

【0050】

本実施形態の画像処理装置10Aに用いられる画像処理方法においては、選択された周辺画素の画素値（ P_{22} を除く $P_{00} \sim P_{44}$ ）と注目画素の画素値（ P_{22} ）との内のいずれか一方又は双方からなるすべての画素値に、同一の重み付けがされたフィルタ係数を乗算している。その後、本実施形態の画像処理方法においては、すべての乗算結果の値を加算することにより、各 5×5 領域の画素値の平均値を順次算出し、前記平均値を、各 5×5 領域の注目画素の画素値（ P_{22} ）としている。そこで、本実施形態の画像処理方法によれば、各 5×5 領域の画素値の平均値を順次算出することにより、ノイズが混入した周辺画素の画素値が突出することを防ぎ、補正された注目画素の画素値（ P_{22} ）を算出することができる。したがって、補正された注目画素の画素値（ P_{22} ）が、ノイズを低減させたものになる。

10

【0051】

<実施形態2>

本発明の実施形態2を、図5及び図6を参照しつつ説明する。図5は、実施形態2の画像処理装置10Bの構成を示すブロック図である。ここでは、実施形態1と同一の構成は同一の符号を付しその説明を省略する。画像処理装置10Bは、図示するように、画像メモリ11Aと、ノイズ判定値算出回路12と、補正回路16A～16Hと、メディアン値算出回路17とを備えている。

20

【0052】

画像メモリ11Aは、実施形態1の画像メモリ11と同様に、SRAMとFFとによって構成されている。画像メモリ11Aの入力端子IN2には、イメージセンサの信号を処理する信号変換部の出力が接続されている。また、ノイズ判定値算出回路12の入力端子は、画像メモリ11Aの注目画素値出力端子D1に接続されている。

【0053】

補正回路16Aの第1入力端子は、ノイズ判定値算出回路12の出力端子に接続されている。補正回路16Aの第2入力端子は、画像メモリ11Aの周辺画素値出力端子D2に接続されている。補正回路16Aの第3入力端子は、画像メモリ11Aの注目画素値出力端子D1に接続されている。

30

【0054】

また、補正回路16B～16Hの各第1入力端子は、補正回路16Aの第1入力端子と同様に、ノイズ判定値算出回路12の出力端子に接続されている。補正回路16B～16Hの各第2入力端子は、画像メモリ11Aの周辺画素値出力端子D2～D9にそれぞれ接続されている。さらに、補正回路16B～16Hの各第3入力端子は、画像メモリ11Aの注目画素値出力端子D1に接続されている。

【0055】

メディアン値算出回路17の入力端子E1は、画像メモリ11Aの注目画素値出力端子D1に接続されている。メディアン値算出回路17の各入力端子E2～E9は、補正回路16A～16Hの各出力端子にそれぞれ接続されている。実施形態2では、メディアン値算出回路17は、メディアンフィルタによって構成されている。なお、図中の符号F1は、メディアン値算出回路17の出力端子である。

40

【0056】

次に、実施形態2の画像処理装置10Bの画像処理方法について説明する。画像メモリ11Aは、実施形態1の画像メモリ11と同様に、ラインデータ毎に、被写体のデジタル画像のデータを記憶する。

【0057】

本実施形態の画像処理装置10Bにおいては、図6に図示するように、画像メモリ11Aが、画像メモリ11Aに記憶されたデジタル画像のデータから、X方向及びY方向に

50

それぞれ3画素ずつの 3×3 領域を抽出する。図中の Q_{11} は注目画素値データを示し、 Q_{11} 以外の全符号 $Q_{00} \sim Q_{22}$ は周辺画素値データを示す。本実施形態では、注目画素値データ Q_{11} からノイズデータを削除したものが、本発明の注目画素の真値に相当する。

【0058】

さらに、画像処理装置10Bにおいては、画像メモリ11Aが、注目画素値出力端子D1から、注目画素値データ Q_{11} を、ノイズ判定値算出回路12、各補正回路16A～16H及びメディアン値算出回路17の入力端子E1に出力する。加えて、画像メモリ11Aは、各周辺画素値出力端子D2～D9から周辺画素値データ Q_{00} 等を、各補正回路16A～16Hにそれぞれ出力する。

10

【0059】

ノイズ判定値算出回路12には、前記注目画素値データ Q_{11} に対応するノイズ判定値 ε が、ルックアップテーブルとして記憶されている。ノイズ判定値算出回路12は、前記注目画素値データ Q_{11} に応じ、ルックアップテーブルからノイズ判定値 ε を読み出し、該ノイズ判定値 ε のデータを、各補正回路16A～16Hに出力する。

【0060】

上述したように、補正回路16A～16Hには、ノイズ判定値 ε のデータ、周辺画素値データ Q_{00} 等及び注目画素値データ Q_{11} がそれぞれ入力されている。

【0061】

補正回路16Aは、最初に、周辺画素の画素値(Q_{00})から注目画素の画素値(Q_{11})を減算する。次に、補正回路16Aは、減算した結果の絶対値を、前記ノイズ判定値 ε と比較する。補正回路16Aは、前記絶対値がノイズ判定値 ε 以下であると判断すると、周辺画素の画素値(Q_{00})を選択する。その後、補正回路16Aは、周辺画素値データ Q_{00} を、メディアン値算出回路17の入力端子E2に出力する。

20

【0062】

一方、補正回路16Aは、前記絶対値がノイズ判定値 ε よりも大きいと判断すると、注目画素の画素値(Q_{11})を選択する。その後、補正回路16Aは、注目画素値データ Q_{11} を、メディアン値算出回路17の入力端子E2に出力する。

【0063】

各補正回路16B～16Hは、上述した補正回路16Aと同様に、周辺画素の画素値(Q_{00} を除く $Q_{01} \sim Q_{22}$)から注目画素の画素値(Q_{11})をそれぞれ減算する。次に、各補正回路16B～16Hは、減算した結果の絶対値を、前記ノイズ判定値 ε とそれぞれ比較する。各補正回路16B～16Hは、各絶対値がノイズ判定値 ε 以下であると判断すると、周辺画素の画素値(Q_{00} を除く $Q_{01} \sim Q_{22}$)をそれぞれ選択する。その後、各補正回路16B～16Hは、周辺画素値データ $Q_{10} \sim Q_{22}$ を、メディアン値算出回路17の各入力端子E3～E9にそれぞれ出力する。

30

【0064】

一方、各補正回路16B～16Hは、前記絶対値がノイズ判定値 ε よりも大きいと判断すると、注目画素の画素値(Q_{11})をそれぞれ選択する。その後、各補正回路16B～16Hは、注目画素値データ Q_{11} を、メディアン値算出回路17の各入力端子E2～E9にそれぞれ出力する。

40

【0065】

メディアン値算出回路17には、上述したように、入力端子E1を介して注目画素値データが入力されている。加えて、メディアン値算出回路17には、上述したように、周辺画素の画素値から注目画素の画素値を減算した結果の絶対値とノイズ判定値 ε との比較結果に応じ、各補正回路16A～16Hによって、入力端子E2～E9を介して、周辺画素値データあるいは注目画素値データが入力されている。メディアン値算出回路17は、入力されたすべての画素値を、値が大きいものから順番に並べ変える。そして、メディアン値算出回路17は、 3×3 領域の注目画素の画素値(Q_{11})として、並べ変えた値の内のメディアン値(中間値)を求めている。メディアン値(中間値)は、前記デジタル

50

画像に混入したノイズを低減するために、注目画素の画素値 (Q_{11}) として求められる。続いて、メディアン値算出回路 17 は、出力端子 F1 から、メディアン値データ Q_{11} を出力する。

【0066】

メディアン値算出回路 17 は、前記デジタル画像の全域に亘って 3×3 領域をそれぞれ抽出し、上述したように、注目画素の画素値 (Q_{11}) として、メディアン値を順次求めている。メディアン値算出回路 17 は、算出した注目画素値データ Q_{11} を、出力端子 F1 から順次出力する。本実施形態の画像処理装置 10B では、前記メディアン値を用いて、前記デジタル画像を復元し、S/N比を改善している。

【0067】

本実施形態では、補正回路 16A ~ 16H は、周辺画素の画素値から注目画素の画素値を減算した結果の絶対値とノイズ判定値 ϵ との比較結果に応じ、デジタル画像の復元に用いられるメディアン値として、周辺画素の画素値又は注目画素の画素値を選択するから、本発明の補正部に相当する。また、本実施形態では、周辺画素の画素値 (Q_{11} を除く $Q_{01} \sim Q_{22}$) 及び注目画素の画素値 (Q_{11}) は、本発明の補正值に相当する。また、本実施形態では、ノイズ判定値算出回路 12 は、ルックアップテーブルによって、注目画素の画素値 (Q_{11}) に対して許容される画素幅 (ノイズ判定値 ϵ) を読み出して選定している。したがって、ノイズ判定値 ϵ を選定するノイズ判定値算出回路 12 は、本発明の選定部に相当する。

【0068】

本実施形態では、周辺画素の画素値から注目画素の画素値を減算した結果の絶対値とノイズ判定値 ϵ との比較結果に応じ、デジタル画像の復元に用いられるメディアン値として、周辺画素の画素値又は注目画素の画素値を選択することが、本発明の補正ステップに相当する。また、本実施形態では、ルックアップテーブルを用い、注目画素の画素値 (Q_{11}) に対して許容される画素幅 (ノイズ判定値 ϵ) を読み出して選定することは、本発明の選定ステップに相当する。

【0069】

<実施形態2の効果>

上述した実施形態2の画像処理装置 10B においては、ノイズ判定値算出回路 12 が、注目画素の画素値 (Q_{11}) に応じて、ノイズ判定値 ϵ を読み出して選定している。そこで、実施形態2の画像処理装置 10B では、注目画素の画素値 (Q_{11}) に応じて、選定するノイズ判定値 ϵ を変化させることができる。

また、本実施形態の画像処理装置 10B によれば、ノイズ判定値算出回路 12 によって選定されたノイズ判定値 ϵ に応じ、各補正回路 16A ~ 16H が、各 3×3 領域の画素値に混入したノイズを低減させる補正值として、周辺画素の画素値 (Q_{11} を除く $Q_{00} \sim Q_{22}$) と注目画素の画素値 (Q_{11}) との内のいずれか一方又は双方を選択している。そこで、各補正回路 16A ~ 16H は、ノイズ判定値 ϵ に応じて、選定する補正值を変化させることができる。したがって、本実施形態の画像処理装置 10B によれば、各補正回路 16A ~ 16H によって選定された補正值により、各 3×3 領域の注目画素の画素値を補正して、補正後の注目画素の画素値を、ノイズを低減させたものにすることができる。

【0070】

さらに、実施形態2の画像処理装置 10B に用いられる画像処理方法によれば、注目画素の画素値 (Q_{11}) に応じて、ノイズ判定値 ϵ を読み出して選定している。そこで、実施形態2の画像処理方法によれば、注目画素の画素値 (Q_{11}) に応じて、選定するノイズ判定値 ϵ を変化させることができる。

また、本実施形態の画像処理装置 10B に用いられる画像処理方法によれば、選定されたノイズ判定値 ϵ に応じ、各 3×3 領域の画素値に混入したノイズを低減させる補正值として、周辺画素の画素値 (Q_{11} を除く $Q_{00} \sim Q_{22}$) と注目画素の画素値 (Q_{11}) との内のいずれか一方又は双方を選択している。そこで、本実施形態の画像処理方法においては、ノイズ判定値 ϵ に応じて、選定する補正值を変化させることができる。したがっ

10

20

30

40

50

て、本実施形態の画像処理方法によれば、選定された補正值により、各 3×3 領域の注目画素の画素値を補正して、補正後の注目画素の画素値を、ノイズを低減させたものにすることができる。

【0071】

本実施形態の画像処理装置10Bにおいては、ノイズ判定値 ε を、周辺画素の画素値(Q11を除くQ00~Q22)から注目画素の画素値(Q11)を減算した結果の絶対値と比較した結果に基づいて、各補正回路16A~16Hが、前記補正值として、周辺画素の画素値と注目画素の画素値との内のいずれか一方又は双方をそれぞれ選択する。そこで、ノイズ判定値 ε を、前記絶対値と比較した結果に基づいて、各補正回路16A~16Hは、選択する補正值を変化させることができる。

10

さらに、本実施形態の画像処理装置10Bに用いられる画像処理方法によれば、ノイズ判定値 ε を、周辺画素の画素値(Q11を除くQ00~Q22)から注目画素の画素値(Q11)を減算した結果の絶対値と比較した結果に基づき、前記補正值として、周辺画素の画素値と注目画素の画素値との内のいずれか一方又は双方を選択する。そこで、本実施形態の画像処理方法によれば、ノイズ判定値 ε を、前記絶対値と比較した結果に基づいて、選択する補正值を変化させることができる。

【0072】

本実施形態の画像処理装置10Bにおいては、各補正回路16A~16Hによって、周辺画素の画素値(Q11を除くQ00~Q22)から注目画素の画素値(Q11)を減算した結果の絶対値が、ノイズ判定値 ε 以下であると判断したことを条件に、前記補正值として、周辺画素の画素値(Q11を除くQ00~Q22)をそれぞれ選択する。そこで、各補正回路16A~16Hによって選択された各周辺画素の画素値は、注目画素の画素値に過度にノイズが混入されたものではなく、補正值にノイズが混入することを抑えることができる。

20

また、本実施形態の画像処理装置10Bによれば、各補正回路16A~16Hによって、周辺画素の画素値(Q11を除くQ00~Q22)から注目画素の画素値(Q11)を減算した結果の絶対値が、ノイズ判定値 ε よりも大きいと判断したことを条件に、前記補正值として、注目画素の画素値(Q11)をそれぞれ選択する。そこで、各補正回路16A~16Hは、補正值として、過度にノイズが混入した周辺画素の画素値を選択することがなく、補正值にノイズが混入することを抑えることができる。

30

【0073】

さらに、本実施形態の画像処理装置10Bに用いられる画像処理方法によれば、周辺画素の画素値(Q11を除くQ00~Q22)から注目画素の画素値(Q11)を減算した結果の絶対値が、ノイズ判定値 ε 以下であると判断したことを条件に、前記補正值として、周辺画素の画素値(Q11を除くQ00~Q22)をそれぞれ選択する。そこで、選択された各周辺画素の画素値は、注目画素の画素値に過度にノイズが混入されたものではなく、補正值にノイズが混入することを抑えることができる。

また、本実施形態の画像処理方法によれば、周辺画素の画素値(Q11を除くQ00~Q22)から注目画素の画素値(Q11)を減算した結果の絶対値が、ノイズ判定値 ε よりも大きいと判断したことを条件に、前記補正值として、注目画素の画素値(Q11)をそれぞれ選択する。そこで、補正值として、過度にノイズが混入した周辺画素の画素値を選択することがなく、補正值にノイズが混入することを抑えることができる。

40

【0074】

本実施形態の画像処理装置10Bにおいては、メディアン値算出回路17が、各補正回路16A~16Hによって選択された周辺画素の画素値(Q11を除くQ00~Q22)と注目画素の画素値(Q11)との内のいずれか一方又は双方からなるすべての画素値からメディアン値を求めている。そして、本実施形態の画像処理装置10Bは、各 3×3 領域のメディアン値を順次求め、前記メディアン値を、各 3×3 領域の注目画素の画素値(Q11)として、メディアン値算出回路17によって求められるメディアン値は、ノイズが混入した周辺画素の画素値に比べて、ノイズを低減させたものになる。

50

したがって、本実施形態の画像処理装置10Bによれば、メディアン値によって定まる注目画素の画素値(Q11')が、ノイズを低減させたものになる。

【0075】

本実施形態の画像処理装置10Bに用いられる画像処理方法においては、選択された周辺画素の画素値(Q11を除くQ00~Q22)と注目画素の画素値(Q11)との内のいずれか一方又は双方からなるすべての画素値からメディアン値を求めている。そして、本実施形態の画像処理方法においては、各3×3領域のメディアン値を順次求め、前記メディアン値を、各3×3領域の注目画素の画素値(Q11')としている。そこで、求められるメディアン値は、ノイズが混入した周辺画素の画素値に比べて、ノイズを低減させたものになる。したがって、本実施形態の画像処理方法によれば、メディアン値によって定まる注目画素の画素値(Q11')が、ノイズを低減させたものになる。

10

【0076】

<実施形態3>

本発明の実施形態3を、図7を参照しつつ説明する。図7は、実施形態3の画像処理装置10Cの構成を示すブロック図である。ここでは、実施形態1及び実施形態2と同一の構成は同一の符号を付しその説明を省略する。画像処理装置10Cは、図示するように、画像メモリ11Aと、ノイズ判定値算出回路12と、メディアン値算出回路17と、画素値決定回路18とを備えている。

【0077】

実施形態2と同様に、画像メモリ11Aには、イメージセンサの信号を処理する信号変換部の出力が接続されている。ノイズ判定値算出回路12の入力端子は、画像メモリ11Aの注目画素値出力端子D1に接続されている。また、メディアン値算出回路17の入力端子E1は、画像メモリ11Aの注目画素値出力端子D1に接続されている。さらに、メディアン値算出回路17の各入力端子E2~E9は、画像メモリ11Aの各周辺画素値出力端子D2~D9にそれぞれ接続されている。

20

【0078】

画素値決定回路18の第1入力端子は、画像メモリ11Aの注目画素値出力端子D1に接続されている。画素値決定回路18の第2入力端子は、ノイズ判定値算出回路12の出力端子に接続されている。画素値決定回路18の第3入力端子は、メディアン値算出回路17の出力端子F1に接続されている。なお、図中の符号G1は、画素値決定回路18の出力端子である。

30

【0079】

次に、実施形態3の画像処理装置10Cの画像処理方法について説明する。本実施形態の画像処理装置10Cにおいては、実施形態2と同様に、画像メモリ11Aに記憶されたデジタル画像のデータから、X方向及びY方向にそれぞれ3画素ずつの3×3領域を抽出する。

【0080】

さらに、画像処理装置10Cにおいては、画像メモリ11Aが、注目画素値出力端子D1から、注目画素値データQ11を、ノイズ判定値算出回路12、メディアン値算出回路17の入力端子E1及び画素値決定回路18の第1入力端子に出力する。加えて、画像メモリ11Aは、各周辺画素値出力端子D2~D9から、周辺画素値データQ00等を、メディアン値算出回路17の各入力端子E2~E9にそれぞれ出力する。

40

【0081】

ノイズ判定値算出回路12は、ノイズ判定値 ε のデータを、画素値決定回路18の第2入力端子に出力する。メディアン値算出回路17には、入力端子E1を介して注目画素値データQ11が入力されている。加えて、上述したように、メディアン値算出回路17には、各入力端子E2~E9を介して周辺画素値データQ00等が入力されている。メディアン値算出回路17は、実施形態2と同様に、メディアン値を求めている。その後、メディアン値算出回路17は、出力端子F1から、メディアン値のデータを、画素値決定回路18の第3入力端子に出力する。

50

【0082】

上述したように、画素値決定回路18には、注目画素値データQ11、ノイズ判定値 ε のデータ、メディアン値のデータがそれぞれ入力されている。画素値決定回路18は、最初に、メディアン値から注目画素の画像値(Q11)を減算する。次に、画素値決定回路18は、減算結果の絶対値を、ノイズ判定値 ε と比較する。画素値決定回路18は、前記絶対値がノイズ判定値 ε 以下であると判断すると、メディアン値を選択する。その後、画素値決定回路18は、出力端子G1から、メディアン値のデータを出力する。

【0083】

一方、画素値決定回路18は、前記絶対値がノイズ判定値 ε よりも大きいと判断すると、注目画素の画素値(Q11)を選択する。その後、画素値決定回路18は、出力端子G1から、注目画素値データQ11を出力する。

10

【0084】

本実施形態の画像処理装置10Cでは、メディアン値算出回路17が、被写体のデジタル画像の全域に亘って 3×3 領域をそれぞれ抽出し、各 3×3 領域毎に、メディアン値を求めている。そして、画素値決定回路18は、前記減算結果の絶対値とノイズ判定値 ε とを順次比較し、比較結果に応じ、注目画素の画素値(Q11')として、メディアン値又は注目画素の画素値(Q11)を順次選択している。その後、画素値決定回路18は、出力端子F1から、メディアン値のデータ又は注目画素値データQ11を順次出力する。メディアン値又は注目画素の画素値(Q11)は、前記デジタル画像に混入したノイズを低減するために、注目画素の画素値(Q11')として選択される。画像処理装置10Cは、前記メディアン値又は前記注目画素の画素値(Q11)を用いて、前記デジタル画像を復元し、S/N比を改善している。

20

【0085】

本実施形態では、画素値決定回路18は、メディアン値から注目画素の画像値(Q11)を減算した結果の絶対値とノイズ判定値 ε との比較結果に応じ、デジタル画像の復元に用いられるメディアン値又は注目画素の画素値(Q11)を選択するから、本発明の補正部に相当する。また、本実施形態では、メディアン値及び注目画素の画素値(Q11)は、本発明の補正值に相当する。また、実施形態2と同様に、ノイズ判定値算出回路12は、本発明の選定部に相当する。

30

【0086】

本実施形態では、メディアン値から注目画素の画像値(Q11)を減算した結果の絶対値とノイズ判定値 ε との比較結果に応じ、デジタル画像の復元に用いられるメディアン値又は注目画素の画素値(Q11)を選択することが、本発明の補正ステップに相当する。なお、本実施形態では、本発明の選定ステップが、実施形態2と同様の処理によって構成されている。

【0087】

<実施形態3の効果>

上述した実施形態3の画像処理装置10Cにおいては、ノイズ判定値算出回路12が、注目画素の画素値(Q11)に応じて、ノイズ判定値 ε を読み出して選定している。そこで、実施形態3の画像処理装置10Cでは、注目画素の画素値(Q11)に応じて、選定するノイズ判定値 ε を変化させることができる。

40

また、本実施形態の画像処理装置10Cによれば、ノイズ判定値算出回路12によって選定されたノイズ判定値 ε に応じ、画素値決定回路18が、各 3×3 領域の画素値に混入したノイズを低減させる補正值として、周辺画素の画素値(Q11を除くQ00~Q22)の内のいずれかであるメディアン値又は注目画素の画素値(Q11)のいずれか一方を選択している。そこで、画素値決定回路18は、ノイズ判定値 ε に応じて、選定する補正值を変化させることができる。したがって、本実施形態の画像処理装置10Cによれば、画像値決定回路18によって選定された補正值により、各 3×3 領域の注目画素の画素値を補正して、補正後の注目画素の画素値を、ノイズを低減させたものにすることができる。

50

【0088】

さらに、実施形態3の画像処理装置10Cに用いられる画像処理方法によれば、注目画素の画素値(Q11)に応じて、ノイズ判定値 ε を読み出して選定している。そこで、実施形態3の画像処理方法によれば、注目画素の画素値(Q11)に応じて、選定するノイズ判定値 ε を変化させることができる。

また、本実施形態の画像処理装置10Cに用いられる画像処理方法によれば、選定されたノイズ判定値 ε に応じ、各3×3領域の画素値に混入したノイズを低減させる補正值として、周辺画素の画素値(Q11を除くQ00～Q22)の内のいずれかであるメディアン値又は注目画素の画素値(Q11)のいずれか一方を選択している。そこで、本実施形態の画像処理方法においては、ノイズ判定値 ε に応じて、選定する補正值を変化させることができる。したがって、本実施形態の画像処理方法によれば、選定された補正值により、各3×3領域の注目画素の画素値を補正して、補正後の注目画素の画素値を、ノイズを低減させたものにする事ができる。

10

【0089】

本実施形態の画像処理装置10Cにおいては、ノイズ判定値 ε を、メディアン値から注目画素の画素値(Q11)を減算した結果の絶対値と比較した結果に基づいて、画素値決定回路18が、前記補正值として、メディアン値又は注目画素の画素値(Q11)を選択する。そこで、ノイズ判定値 ε を、前記絶対値と比較した結果に基づいて、画素値決定回路18は、選択する補正值を変化させることができる。

さらに、本実施形態の画像処理装置10Cに用いられる画像処理方法によれば、ノイズ判定値 ε を、メディアン値から注目画素の画素値(Q11)を減算した結果の絶対値と比較した結果に基づき、前記補正值として、メディアン値又は注目画素の画素値(Q11)を選択する。そこで、ノイズ判定値 ε を、前記絶対値と比較した結果に基づいて、選択する補正值を変化させることができる。

20

【0090】

本実施形態の画像処理装置10Cにおいては、メディアン値から注目画素の画素値(Q11)を減算した結果の絶対値が、ノイズ判定値 ε 以下であると判断したことを条件に、画素値決定回路18によって、前記補正值としてメディアン値を選択する。そこで、画素値決定回路18によって選択されたメディアン値は、注目画素の画素値に過度にノイズが混入されたものではなく、補正值にノイズが混入することを抑えることができる。

30

また、本実施形態の画像処理装置10Cによれば、メディアン値から注目画素の画素値(Q11)を減算した結果の絶対値が、ノイズ判定値 ε よりも大きいと判断したことを条件に、画素値決定回路18によって、前記補正值として、注目画素の画素値(Q11)を選択する。そこで、画素値決定回路18は、補正值として、過度にノイズが混入したメディアン値を選択することがなく、補正值にノイズが混入することを抑えることができる。

【0091】

さらに、本実施形態の画像処理装置10Cに用いられる画像処理方法によれば、メディアン値から注目画素の画素値(Q11)を減算した結果の絶対値が、ノイズ判定値 ε 以下であると判断したことを条件に、前記補正值としてメディアン値を選択する。そこで、選択されたメディアン値は、注目画素の画素値に過度にノイズが混入されたものではなく、補正值にノイズが混入することを抑えることができる。

40

また、本実施形態の画像処理方法によれば、メディアン値から注目画素の画素値(Q11)を減算した結果の絶対値が、ノイズ判定値 ε よりも大きいと判断したことを条件に、前記補正值として、注目画素の画素値(Q11)を選択する。そこで、補正值として、過度にノイズが混入したメディアン値を選択することがなく、補正值にノイズが混入することを抑えることができる。

【0092】

<実施形態4>

本発明の実施形態4を、図8を参照しつつ説明する。図8は、実施形態4の画像処理装置10Dの構成を示すブロック図である。ここでは、実施形態1ないし実施形態3と同一

50

の構成は同一の符号を付しその説明を省略する。画像処理装置 10D は、図示するように、画像メモリ 11A と、ノイズ判定値算出回路 12 と、第 2 判定・係数乗算回路 19A ～ 19H と、加減算回路 20 とを備えている。

【0093】

実施形態 2 及び実施形態 3 と同様に、画像メモリ 11A には、イメージセンサの信号を処理する信号変換部の出力が接続されている。ノイズ判定値算出回路 12 の入力端子は、画像メモリ 11A の注目画素値出力端子 D1 に接続されている。

【0094】

第 2 判定・係数乗算回路 19A の第 1 入力端子は、ノイズ判定値算出回路 12 の出力端子に接続されている。第 2 判定・係数乗算回路 19A の第 2 入力端子は、画像メモリ 11A の注目画素値出力端子 D1 に接続されている。

10

【0095】

第 2 判定・係数乗算回路 19B の第 1 入力端子は、ノイズ判定値算出回路 12 の出力端子に接続されている。第 2 判定・係数乗算回路 19B の第 2 入力端子は、画像メモリ 11A の周辺画素値出力端子 D2 に接続されている。第 2 判定・係数乗算回路 19B の第 3 入力端子は、画像メモリ 11A の注目画素値出力端子 D1 に接続されている。

【0096】

第 2 判定・係数乗算回路 19C ～ 19H の各第 1 入力端子は、第 2 判定・係数乗算回路 19B の第 1 入力端子と同様に、ノイズ判定値算出回路 12 の出力端子に接続されている。第 2 判定・係数乗算回路 19C ～ 19H の各第 2 入力端子は、画像メモリ 11A の周辺画素値出力端子 D3 ～ D9 にそれぞれ接続されている。第 2 判定・係数乗算回路 19C ～ 19H の各第 3 入力端子は、画像メモリ 11A の注目画素値出力端子 D1 に接続されている。

20

【0097】

加減算回路 20 の入力端子 H1 は、画像メモリ 11A の注目画素値出力端子 D1 に接続されている。加減算回路 20 の入力端子 H2 ～ H9 は、第 2 判定・係数乗算回路 19A ～ 19H の出力端子にそれぞれ接続されている。なお、図中の符号 I1 は、加減算回路 20 の出力端子である。

【0098】

次に、実施形態 4 の画像処理装置 10D の画像処理方法について説明する。本実施形態の画像処理装置 10D においては、実施形態 2 及び実施形態 3 と同様に、画像メモリ 11A に記憶されたデジタル画像のデータから、前記 3×3 領域を抽出する。

30

【0099】

さらに、画像処理装置 10D においては、画像メモリ 11A が、注目画素値出力端子 D1 から、注目画素値データ Q11 を、ノイズ判定値算出回路 12、各第 2 判定・係数乗算回路 19A ～ 19H 及び加減算回路 20 の入力端子 H1 に出力する。加えて、画像メモリ 11A は、各周辺画素値出力端子 D2 ～ D9 から、周辺画素値データ Q00 等を、各第 2 判定・係数乗算回路 19B ～ 19H の第 2 入力端子にそれぞれ出力する。

【0100】

ノイズ判定値算出回路 12 は、ノイズ判定値 ε のデータを、各第 2 判定・係数乗算回路 19A ～ 19H の第 1 入力端子に出力する。第 2 判定・係数乗算回路 19A には、注目画素値データ Q11、ノイズ判定値 ε のデータが入力されている。また、各第 2 判定・係数乗算回路 19B ～ 19H には、注目画素値データ Q11、周辺画素値データ Q00 等及びノイズ判定値 ε のデータがそれぞれ入力されている。

40

【0101】

第 2 判定・係数乗算回路 19A は、最初に、注目画素の画素値 (Q11) から注目画素の画素値 (Q11) を減算する。次に、第 2 判定・係数乗算回路 19A は、減算結果の絶対値を、ノイズ判定値 ε と比較する。第 2 判定・係数乗算回路 19A は、前記絶対値がノイズ判定値 ε 以下であると判断し、前記減算結果の値を選択する。

【0102】

50

続いて、第2判定・係数乗算回路19Aは、前記減算結果の値に平滑化係数を乗算する。その後、第2判定・係数乗算回路19Aは、乗算結果の値を、加減算回路20の入力端子H2に出力する。

【0103】

第2判定・係数乗算回路19Bは、最初に、周辺画素の画素値(Q00)から注目画素の画素値(Q11)を減算する。次に、第2判定・係数乗算回路19Bは、減算結果の絶対値を、ノイズ判定値 ε と比較する。第2判定・係数乗算回路19Bは、前記絶対値がノイズ判定値 ε 以下であると判断すると、前記減算結果の値を選定する。

【0104】

続いて、第2判定・係数乗算回路19Bは、前記減算結果の値に平滑化係数を乗算する。その後、第2判定・係数乗算回路19Bは、乗算結果の値を加減算回路20の入力端子H3に出力する。

10

【0105】

一方、第2判定・係数乗算回路19Bは、前記絶対値がノイズ判定値 ε よりも大きいと判断すると、予め設定した値を選択する。本実施形態では、第2判定・係数乗算回路19Bが、前記絶対値がノイズ判定値 ε よりも大きいと判断すると、注目画素の画素値(Q11)を選択する。続いて、第2判定・係数乗算回路19Bは、注目画素の画素値(Q11)に平滑化係数を乗算する。その後、第2判定・係数乗算回路19Bは、乗算結果の値を加減算回路20の入力端子H3に出力する。

【0106】

各第2判定・係数乗算回路19C～19Hは、上述した第2判定・係数乗算回路19Bと同様に、周辺画素の画素値(Q00及びQ11を除くQ01～Q22)から注目画素の画素値(Q11)をそれぞれ減算する。次に、第2判定・係数乗算回路19C～19Hは、減算結果の絶対値を、前記ノイズ判定値 ε とそれぞれ比較する。各第2判定・係数乗算回路19C～19Hは、各絶対値がノイズ判定値 ε 以下であると判断すると、前記減算結果の値をそれぞれ選択する。

20

【0107】

続いて、各第2判定・係数乗算回路19C～19Hは、前記減算結果の値に平滑化係数を乗算する。その後、各第2判定・係数乗算回路19C～19Hは、乗算結果の値を加減算回路20の各入力端子H4～H9にそれぞれ出力する。

30

【0108】

一方、各第2判定・係数乗算回路19C～19Hは、減算結果の絶対値がノイズ判定値 ε よりも大きいと判断すると、前記第2判定・係数乗算回路19Bと同様に、注目画素の画素値(Q11)を選択する。続いて、各第2判定・係数乗算回路19C～19Hは、注目画素の画素値(Q11)に平滑化係数を乗算する。その後、各第2判定・係数乗算回路19C～19Hは、乗算結果の値を加減算回路20の入力端子H4～H9にそれぞれ出力する。

【0109】

加減算回路20は、最初に、各入力端子H2～H9に入力されたすべての乗算結果の値を、加算する。その後、加減算回路20は、入力端子H1に入力された注目画素の画素値(Q11)に、前記乗算結果の値を加算又は減算する。ここでは、前記減算結果が正の値を有するため、前記乗算結果が正の値を有する場合には、加減算回路20は、注目画素の画素値(Q11)に、乗算結果の値を加算する。これに対し、前記減算結果が負の値を有するため、前記乗算結果が負の値を有する場合には、加減算回路20は、注目画素の画素値(Q11)から、前記乗算結果の値を減算する。

40

【0110】

注目画素の画素値(Q11)に前記乗算結果を加算又は減算した値は、前記デジタル画像に混入したノイズを低減するための注目画素の画素値(Q11')となる。加減算回路20は、出力端子I1から、注目画素値データQ11'を出力する。

【0111】

50

加減算回路20は、前記デジタル画像の全域に亘って3×3領域をそれぞれ抽出し、上述した注目画素の画素値(Q11')を算出する。加減算回路20は、算出した注目画素値データQ11'を、出力端子11から順次出力する。本実施形態の画像処理装置10Dでは、前記注目画素の画素値(Q11')を用いて、前記デジタル画像を復元し、S/N比を改善している。なお、本実施形態では、各第2判定・係数乗算回路19A～19H及び加減算回路20が、εフィルタ30を構成する。

【0112】

本実施形態では、各第2判定・係数乗算回路19B～19Hが、ノイズ判定値εを、周辺画素の画素値(Q11を除くQ01～Q22)から注目画素の画素値(Q11)を減算した値の絶対値と比較している。したがって、前記絶対値と比較するノイズ判定値εは、本発明の基準値に相当する。また、実施形態1ないし実施形態3と同様に、ノイズ判定値算出回路12は、本発明の選定部に相当する。

10

【0113】

本実施形態では、ノイズ判定値εを、周辺画素の画素値(Q11を除くQ01～Q22)から注目画素の画素値(Q11)を減算した値の絶対値と比較することが、本発明の比較ステップに相当する。また、実施形態1ないし実施形態3と同様に、ルックアップテーブルを用い、注目画素の画素値(Q11)に対して許容される画素幅(ノイズ判定値ε)を読み出して選定することは、本発明の選定ステップに相当する。

【0114】

<実施形態4の効果>

上述した実施形態4の画像処理装置10Dにおいては、ノイズ判定値算出回路12が、注目画素の画素値(Q11)に応じて、ノイズ判定値εを読み出して選定している。そこで、実施形態4の画像処理装置10Dでは、注目画素の画素値(Q11)に応じて、選定するノイズ判定値εを変化させることができる。

20

また、本実施形態の画像処理装置10Dでは、εフィルタ30が、ノイズ判定値算出回路12によって選定されたノイズ判定値εを、周辺画素の画素値(Q11を除くQ00～Q22)から注目画素の画素値(Q11)をそれぞれ減算した値の絶対値と比較する基準値としている。そこで、本実施形態の画像処理装置10Dによれば、前記基準値は、注目画素の画素値(Q11)に応じて選定されたノイズ判定値εと共に変化することになり、εフィルタ30で用いられる基準値を、注目画素の画素値(Q11)に応じて変化させることができる。

30

【0115】

さらに、実施形態4の画像処理装置10Dに用いられる画像処理方法によれば、注目画素の画素値(Q11)に応じて、ノイズ判定値εを読み出して選定している。そこで、実施形態4の画像処理方法によれば、注目画素の画素値(Q11)に応じて、選定するノイズ判定値εを変化させることができる。

また、本実施形態の画像処理装置10Dに用いられる画像処理方法によれば、選定されたノイズ判定値εを、周辺画素の画素値(Q11を除くQ00～Q22)から注目画素の画素値(Q11)をそれぞれ減算した値の絶対値と比較している。そこで、本実施形態の画像処理方法によれば、前記絶対値と比較するノイズ判定値εを、注目画素の画素値(Q11)に応じて変化させることができ、注目画素の画素値(Q11)の変化に対応させて最適なノイズ判定値εを選定することができる。

40

【0116】

本発明は、上述した実施形態に限定されるものではなく、発明の趣旨を逸脱しない範囲内において構成の一部を適宜変更して実施することができる。例えば、上述した実施形態とは異なり、ルックアップテーブルに代えて、図9中の実線で図示するような、注目画素値の画素値とノイズ判定値εとの対応関係を表す近似式を、ノイズ判定値算出回路12に記憶させてもよい。これによって、図9中の破線で図示するような、注目画素の画素値とノイズ判定値εとの対応関係を忠実に表す式を用いて、ノイズ判定値算出回路12が、注目画素の画素値に応じたノイズ判定値εを算出する場合に比べ、ノイズ判定値算出回路1

50

2がノイズ判定値 ε を算出するために要する負担を軽減させることができる。そこで、ノイズ判定値 ε を算出するために要する負担が軽減されることに合わせて、ノイズ判定値算出回路12の回路構成を簡略化することができる。

また、上述した実施形態の画像処理方法とは異なり、ルックアップテーブルに代えて、図9中の実線で図示するような、注目画素の画素値とノイズ判定値 ε との対応関係を表す近似式を用い、ノイズ判定値 ε を算出してもよい。これによって、図9中の破線で図示するような、注目画素の画素値とノイズ判定値 ε との対応関係を忠実に表す式を用いて、注目画素の画素値に応じたノイズ判定値 ε を算出する場合に比べ、ノイズ判定値 ε を算出するために要する負担を軽減させることができる。

【0117】

上述した実施形態1とは異なり、フィルタテーブルの各フィルタ係数の重み付けを異ならせてもよい。また、上述した実施形態の画像処理装置10A~10Dでは、デジタル画像のデータから、 5×5 領域や 3×3 領域を抽出しているが、抽出領域は適宜に変更してもよい。さらに、上述した実施形態1とは異なり、ノイズの標準偏差 σ に代えて、平均偏差等の他の偏差を用いて、ノイズ判定値 ε を設定してもよい。

【0118】

本発明の技術思想により背景技術における課題を解決するための手段を、以下に列記する。

(付記1) 注目画素の周囲に位置する周辺画素を反映させながら、前記注目画素に含まれるノイズを低減する画像処理装置において、

前記注目画素の真値に応じ、前記注目画素の画素値として、前記真値に対して許容される画素幅を選定する選定部と、

前記選定部によって選定された前記画素幅に応じ、前記注目画素の画素値を補正する補正值として、前記周辺画素の画素値と前記注目画素の画素値との内のいずれか一方又は双方を抽出する補正部と、

を備えることを特徴とする画像処理装置。

(付記2) 注目画素の周囲に位置する周辺画素を反映させながら、前記注目画素に含まれるノイズを低減する画像処理装置において、

前記注目画素の真値に応じ、前記注目画素の画素値として、前記真値に対して許容される画素幅を選定する選定部と、

前記選定部によって選定された前記画素幅を、前記周辺画素の画素値と前記注目画素の画素値との差分値と比較する基準値とした ε フィルタと、

を備えることを特徴とする画像処理装置。

(付記3) 前記選定部は、前記画素幅を、前記注目画素の画素値の分布における標準偏差に基づいて定めることを特徴とする付記1又は付記2に記載の画像処理装置。

(付記4) 前記選定部は、前記注目画素の画素値と前記画素幅との対応関係が格納されたルックアップテーブルを備えることを特徴とする付記3に記載の画像処理装置。

(付記5) 前記選定部は、前記注目画素の画素値と前記画素幅との対応関係を表す近似式により、前記画素幅を算出することを特徴とする付記3に記載の画像処理装置。

(付記6) 前記補正部は、前記画素幅を、前記周辺画素の画素値と前記注目画素の画素値との差分値と比較した比較結果に基づいて、前記補正值として、前記周辺画素の画素値と前記注目画素の画素値との内のいずれか一方又は双方を抽出することを特徴とする付記1に記載の画像処理装置。

(付記7) 前記補正部は、前記比較結果に基づいて、前記差分値が前記画素幅以下であると判断したことを条件に、前記補正值として前記周辺画素の画素値を抽出し、前記比較結果に基づいて、前記差分値が前記画素幅よりも大きいと判断したことを条件に、前記補正值として前記注目画素の画素値を抽出することを特徴とする付記6に記載の画像処理装置。

(付記8) 前記補正部は、前記画素幅を、前記周辺画素の画素値及び前記注目画素の画素値のすべての画素値の内のメディアン値と前記注目画素の画素値との差分値と比較した

10

20

30

40

50

比較結果に基づいて、前記補正值として、前記メディアン値あるいは前記注目画素の画素値を抽出することを特徴とする付記 1 に記載の画像処理装置。

(付記 9) 前記補正部は、前記比較結果に基づいて、前記差分値が前記画素幅以下であると判断したことを条件に、前記補正值として前記メディアン値を抽出し、前記比較結果に基づいて、前記差分値が前記画素幅よりも大きいと判断したことを条件に、前記補正值として前記注目画素の画素値を抽出することを特徴とする付記 8 に記載の画像処理装置。

(付記 10) 前記補正部によって抽出された前記周辺画素の画素値と前記注目画素の画素値との内のいずれか一方又は双方からなるすべての画素値を重み付き平均して前記注目画素の画素値を算出する平滑化フィルタを備えることを特徴とする付記 7 に記載の画像処理装置。

10

(付記 11) 前記補正部によって抽出された前記周辺画素の画素値と前記注目画素の画素値との内のいずれか一方又は双方からなるすべての画素値からメディアン値を選定し、該メディアン値を前記注目画素の画素値とするメディアンフィルタを備えることを特徴とする付記 7 に記載の画像処理装置。

(付記 12) 注目画素の周囲に位置する周辺画素を反映させながら、前記注目画素に含まれるノイズを低減する画像処理装置に用いられる画像処理方法において、

前記注目画素の真値に応じ、前記注目画素の画素値として、前記真値に対して許容される画素幅を選定する選定ステップと、

前記選定ステップによって選定された前記画素幅に応じ、前記注目画素の画素値を補正する補正值として、前記周辺画素の画素値と前記注目画素の画素値との内のいずれか一方又は双方を抽出する補正ステップと、

を備えることを特徴とする画像処理方法。

20

(付記 13) 注目画素の周囲に位置する周辺画素を反映させながら、前記注目画素に含まれるノイズを低減する画像処理装置に用いられる画像処理方法において、

前記注目画素の真値に応じ、前記注目画素の画素値として、前記真値に対して許容される画素幅を選定する選定ステップと、

前記選定ステップによって選定された前記画素幅を、前記周辺画素の画素値と前記注目画素の画素値との差分値と比較する比較ステップと、

を備えることを特徴とする画像処理方法。

(付記 14) 前記選定ステップは、前記画素幅を、前記注目画素の画素値の分布における標準偏差に基づいて定めることを特徴とする付記 12 又は付記 13 に記載の画像処理方法。

30

(付記 15) 前記選定ステップは、前記注目画素の画素値と前記画素幅との対応関係が格納されたルックアップテーブルによって、前記画素幅を選定することを特徴とする付記 14 に記載の画像処理方法。

(付記 16) 前記選定ステップは、前記注目画素の画素値と前記画素幅との対応関係を表す近似式により、前記画素幅を算出することを特徴とする付記 14 に記載の画像処理方法。

(付記 17) 前記補正ステップは、前記画素幅を、前記周辺画素の画素値と前記注目画素の画素値との差分値と比較した比較結果に基づいて、前記補正值として、前記周辺画素の画素値と前記注目画素の画素値との内のいずれか一方又は双方を抽出することを特徴とする付記 12 に記載の画像処理方法。

40

(付記 18) 前記補正ステップは、前記比較結果に基づいて、前記差分値が前記画素幅以下であると判断したことを条件に、前記補正值として前記周辺画素の画素値を抽出し、前記比較結果に基づいて、前記差分値が前記画素幅よりも大きいと判断したことを条件に、前記補正值として前記注目画素の画素値を抽出することを特徴とする付記 17 に記載の画像処理方法。

(付記 19) 前記補正ステップは、前記画素幅を、前記周辺画素の画素値及び前記注目画素の画素値のすべての画素値の内のメディアン値と前記注目画素の画素値との差分値と比較した比較結果に基づいて、前記補正值として、前記メディアン値あるいは前記注目画

50

素の画素値を抽出することを特徴とする付記 1 2 に記載の画像処理方法。

(付記 2 0) 前記補正ステップは、前記比較結果に基づいて、前記差分値が前記画素幅以下であると判断したことを条件に、前記補正值として前記メディアン値を抽出し、前記比較結果に基づいて、前記差分値が前記画素幅よりも大きいと判断したことを条件に、前記補正值として前記注目画素の画素値を抽出することを特徴とする付記 1 9 に記載の画像処理方法。

【図面の簡単な説明】

【0 1 1 9】

- 【図 1】実施形態 1 に係る画像処理装置の概略構成図である。
- 【図 2】実施形態 1 に用いられるデジタル画像中の抽出領域の概略説明図である。
- 【図 3】注目画素の画素値に対するノイズ判定値の変化を示すグラフである。
- 【図 4】実施形態 1 に用いられるフィルタテーブルの概略説明図である。
- 【図 5】実施形態 2 に係る画像処理装置の概略構成図である。
- 【図 6】実施形態 2 に用いられるデジタル画像中の抽出領域の概略説明図である。
- 【図 7】実施形態 3 に係る画像処理装置の概略構成図である。
- 【図 8】実施形態 4 に係る画像処理装置の概略構成図である。
- 【図 9】注目画素の画素値に対するノイズ判定値の近似変化を示すグラフである。
- 【図 1 0】注目画素の画素値に対するノイズの存在確率の分布曲線である。
- 【図 1 1】注目画素の画素値に対するノイズの標準偏差の変化を示すグラフである。

10

【符号の説明】

20

【0 1 2 0】

- 1 0 A ~ 1 0 D 画像処理装置
- 3 0 ε フィルタ
- P 0 0 ~ P 2 1、P 2 3 ~ P 4 4 周辺画素の画素値
- P 2 2 注目画素の画素値
- Q 0 0 ~ Q 1 0、Q 1 2 ~ Q 2 2 周辺画素の画素値
- Q 1 1 注目画素の画素値

【図1】

実施形態1に係る画像処理装置の概略構成図

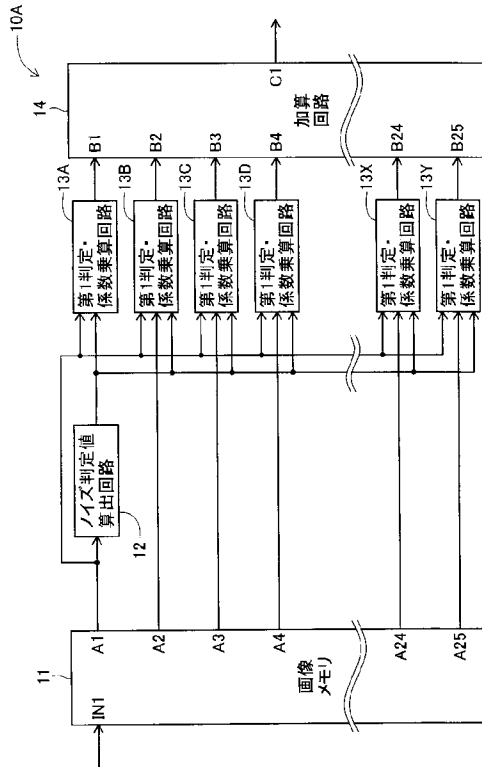

【図2】

実施形態1に用いられるデジタル画像中の抽出領域の概略説明図

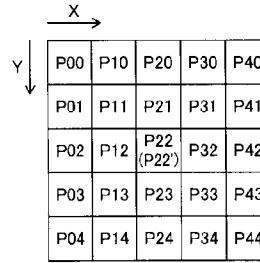

【図3】

注目画素の画素値に対するノイズ判定値の変化を示すグラフ

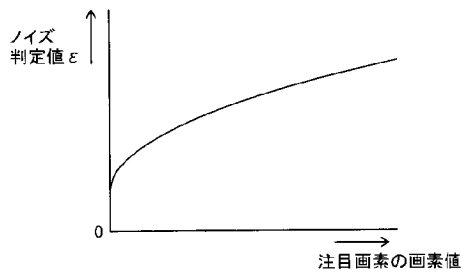

【図4】

実施形態1に用いられるフィルタテーブルの概略説明図

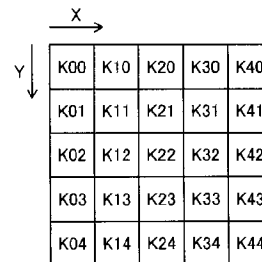

【図 5】

実施形態2に係る画像処理装置の概略構成図

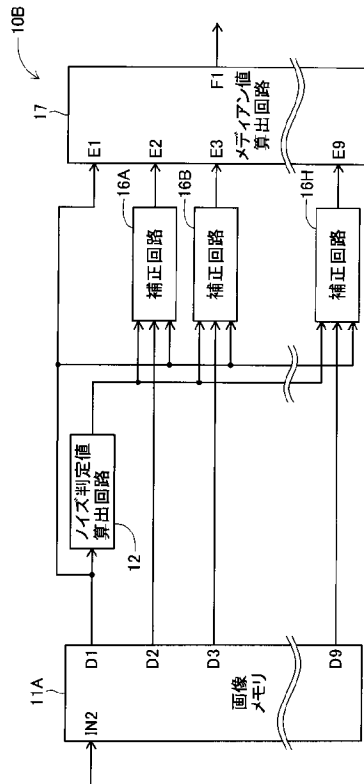

【図 6】

実施形態2に用いられるデジタル画像中の抽出領域の概略説明図

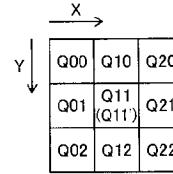

【図 7】

実施形態3に係る画像処理装置の概略構成図

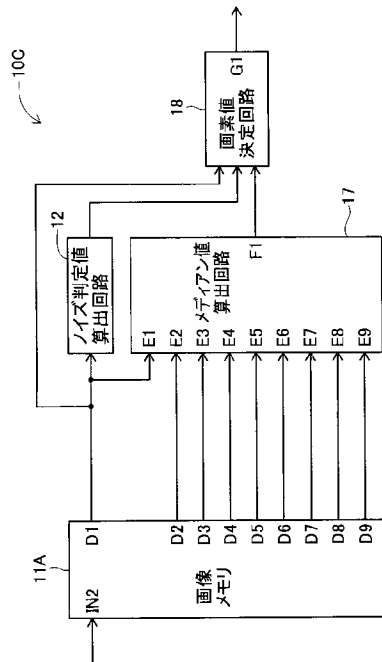

【図 8】

実施形態4に係る画像処理装置の概略構成図

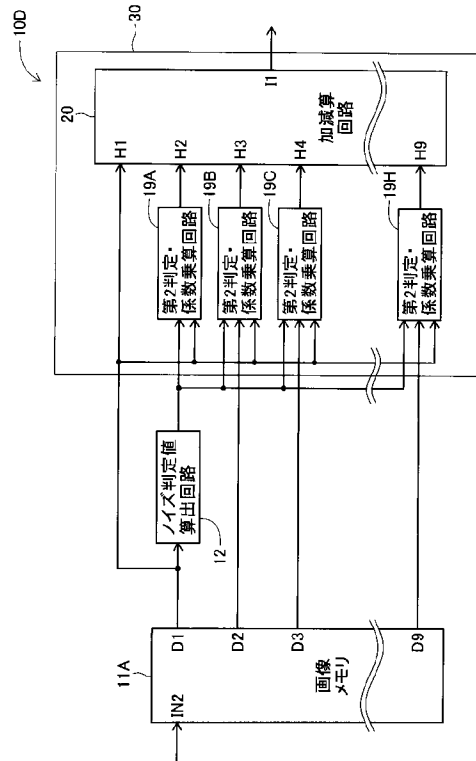

【図 9】

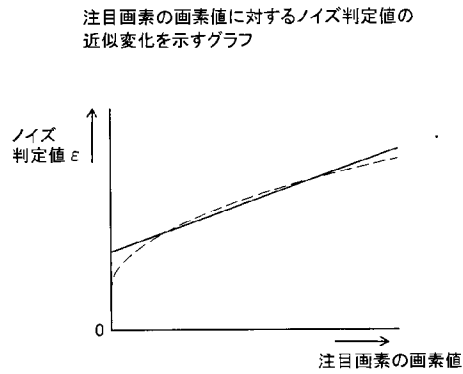

【図 10】

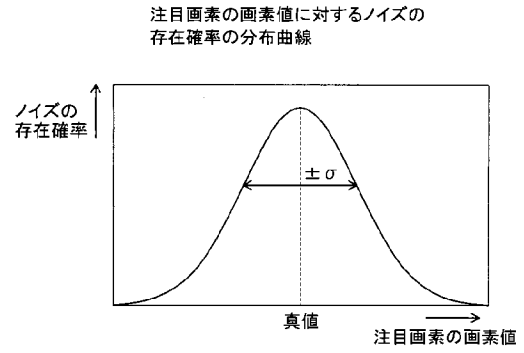

【図 11】

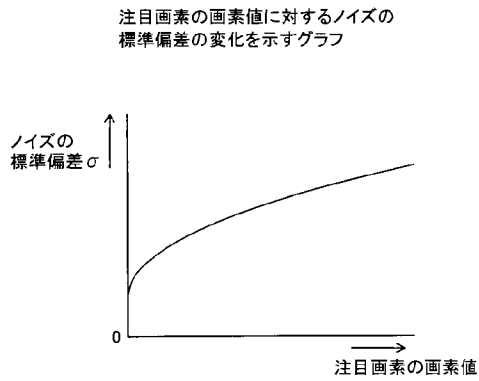

フロントページの続き

F ターム(参考) 5C024 CX03 HX04 HX14 HX21 HX29 HX50
5C077 LL02 LL19 MP01 PP02 PP54 PP68 PQ08 PQ20

Bibliographic Data

Int.Cl.	H04N 5/225 H04N 5/91
Published Date	20150106
Registration No.	1014783800000
Registration Date	20141224
Application No.	1020097023045
Application Date	20091104
Unexamined Publication No.	1020100016214
Unexamined Publication Date	20100212
Priority Claims	60/911,196 20070411 US 61/017,406 20071228 US
Requested Date of Examination	20130410
Agent.	MUHANN PATENT & LAW FIRM
Inventor	JANNARD, James NATTRESS, Thomas, Graeme

발명의 명칭

비디오 카메라

Title of Invention

Video camera.

요약

비디오 카메라는 외형적으로 손실 없는 방법으로 비디오 데이터를 상당히 압축하기 위해서 구성될 수 있다. 카메라는 데이터의 압축성을 향상시키는 수단으로 블루와 레드 이미지 데이터를 변형하기 위해 구성될 수 있다. 게다가, 데이터는 이러한 형태로 압축되거나 저장될 수 있다. 이것은 사용자가 디모자이크 시 외형적으로는 손실 없는 오리지널 로(Raw) 데이터의 변형된 버전을 위해 오리지널 로 데이터를 얻기 위해 레드 및 블루 데이터를 재구성하는 것을 가능하게 한다. 게다가, 데이터는 그린 이미지 엘리먼트들이 처음으로 디모자이크되고, 이후 레드와 블루 엘리먼트들이 디모자이크된 그린 이미지 엘리먼트들의 값에 기초하여 구성되는 방법으로 프로세스 될 수 있다.

비디오, 카메라, 압축, 그린, 레드, 블루, 엘리먼트, 이미지, 동영상

Abstract

Blue and red image data are configured to be changed to the means improving the camera is the compressibility of data in order to considerably compress video data the video camera can be comprised of the method for the here being externally no with loss. Moreover, it is compressed to this form or data can be stored. It makes it possible that the user reconstructs red and blue data to the original (Raw) which there is no in the demosaic with loss in order to obtain data for the transformed version of data from original. Moreover, image elements which data draw are for the first time demosaiced. It can be processed to the method for being comprised based on the value of image elements in which red and blue elements are thereafter demosaiced drawn.

The video, camera, compression, green, red, blue, element, image, moving picture

대표도면 (Representative drawing)

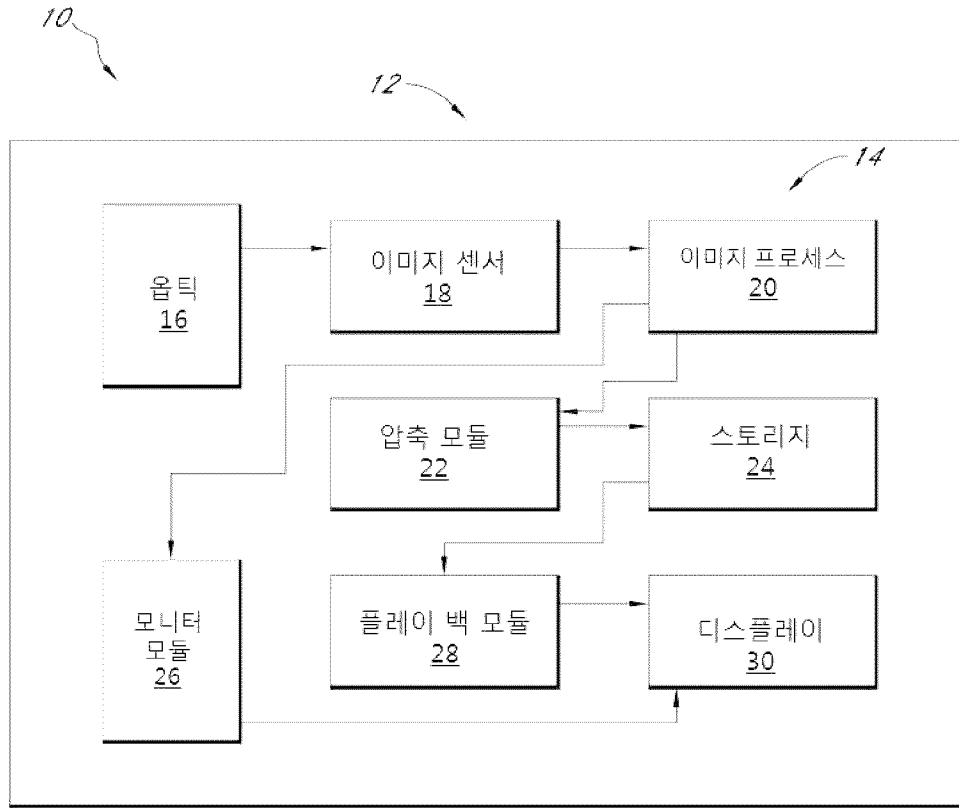

청구의 범위

Scope of Claims

청구 1항:

Claim 1:

포터블 하우징; 상기 하우징에 의해 지지되고, 라이트(light)를 포커싱 하기 위해 구성된 렌즈 어셈블리; 포커싱 된 라이트(light)를 적어도 초당 23프레임의 프레임 비에서 적어도 2K의 해상력을 가지는, 상기 포커싱된 라이트(light)의 적어도 제1, 제2 및 제3 컬러를 나타내는 로(raw) 모자이크된(mosaiced) 이미지 데이터로 변환하기 위해 구성된 라이트(light) 검출 디바이스; 메모리 디바이스; 및 외형적인 무손실을 유지하도록, 로(raw) 모자이크된 이미지 데이터를 메모리 디바이스에 압축하고 저장하기 위해 구성된 이미지 프로세싱 시스템을 포함하고, 상기 이미지 프로세싱 시스템은 제1 평균 값을 획득하기 위해 상기 제1 컬러의 센서 셀 주위의 적어도 네 개의 센서 셀로부터 상기 제3 컬러의 이미지 데이터의 평균 값을 계산하고, 제2 평균 값을 획득하기 위해 상기 제2 컬러의 센서 셀 주위의 적어도 네 개의 센서 셀로부터 상기 제3 컬러의 이미지 데이터의 평균 값을 계산하며, 상기 제1 컬러의 상기 센서 셀로부터 상기 이미지 데이터의 값으로부터 상기 제1 평균 값을 공제(subtract) 하고 상기 제2 컬러의 상기 센서 셀로부터 상기 이미지 데이터의 값으로부터 상기 제2 평균 값을 공제함으로써 상기 이미지 데이터를 변경(modify)하도록 구성되는 이미지 프로세싱 모듈을 포함하고, 상기 공제 후(following the subtraction) 상기 이미지 프로세싱 시스템은 상기 변경된 로(raw) 모자이크된 이미지 데이터를 압축하고 상기 압축된 로(raw) 모자이크된 이미지 데이터를 초당 적어도 23프레임의 비율에서 저장하도록 구성되는, 비디오 카메라.

Portable housing, the lens assembly, the light detection device, memory device, and the image processing system are included ; the average value of image data of the third color is calculated from the sensor cell of at least four of the sensor cell surrounding of the first color so that the image processing system obtain the first average value ; and the average value of image data of the third color is calculated from the sensor cell of at least four of the sensor cell surrounding of the second color in order to gain the second average value, and the lens assembly is supported by housing ; and is configured to focus the light; the light detection device is configured to convert the focused light into image data mosaiced the furnace (raw) (mosaiced) which shows at least first and second and the third color of the focused light as described above to per second go to the definition of at least 2K from the frame rate of 23 frame at least; and the image processing system maintains the externally lossless ; and it is configured to compress and is configured to store image data mosaiced the furnace (raw) in the memory device. The video camera which includes the image processing module which is configured to image data the change (modify) by subtracting the first average value the second average value from the sensor cell of the first color from the value of image data a from the sensor cell of the second color and subtraction from the value of image data ; and per second is configured to store image data compressing image data in which the subtraction after (following the subtraction) image processing system is mosaiced the changed furn

ace (raw) as described above and are mosaiced the compacted furnace (raw) as described above in the rate of at least 23 frame.

청구 2항:

Claim 2:

청구 3항:

Claim 3:

제1항에 있어서,상기 제 3컬러는 그린인 것을 특징으로 하는 비디오 카메라.

As for claim 1, the video camera called the third color is green.

청구 4항:

Claim 4:

청구 5항:

Claim 5:

청구 6항:

Claim 6:

제1항에 있어서상기 이미지 프로세싱 시스템은상기 제 3컬러를 나타내는 이미지 데이터의 반을 삭제하기 위해 구성되는 비디오 카메라.

The video camera which is configured to delete the half of image data of claim 1, wherein *** Seo SangGi image processing system silver prize base 3 color is shown.

청구 7항:

Claim 7:

제 6항에 있어서,상기 라이트(light) 검출 디바이스는, 제 1컬러를 검출하기 위해 구성된 센서 셀의 제 1 그룹,제 2컬러를 검출하기 위해 구성된 센서 셀의 제 2 그룹,제 3컬러를 검출하기 위해 구성된 센서 셀의 제 3 그룹을 포함하고,상기 센서 셀의 제 3 그룹은 센서 셀의 제 2 그룹보다 두 배 많은 센서 셀을 포함하는 비디오 카메라.

As for claim 6, the video camera wherein: the light detection device comprises the sensor cell in which it includes the first group of the sensor cell, the second group of the sensor cell, and the third group of the sensor cell ; and the third group of the sensor cell is more than the second group of the sensor cell with the twice; the first group of the sensor cell is configured to detect the first color; the second group of the sensor cell is configured to detect the second color; and the third group of the sensor cell is configured to detect the third color.

청구 8항:

Claim 8:

제 1항에 있어서,상기 메모리 디바이스는 하우징 내에 배열된 비디오 카메라.

As for claim 1, the video camera in which the memory device is arranged within housing.

청구 9항:

Claim 9:

제 1항에 있어서,상기 메모리 디바이스는 하우징 외측상에 지지되는 비디오 카메라.

As for claim 1, the video camera in which the memory device is supported on the housing external.

청구 10항:

Claim 10:

제 1항에 있어서, 상기 메모리 디바이스는 신축 케이블을 가지고 하우징에 연결되는 비디오 카메라.

As for claim 1, the video camera in which the memory device is connected to housing having expansion and contraction cable.

청구 11항:

Claim 11:

제 1항에 있어서, 상기 이미지 프로세싱 시스템은 압축 이전으로(raw) 이미지 데이터의 엔트로피를 감소하기 위하여 로(raw) 모자이크된 이미지 데이터를 조작하기 위해 구성되는 비디오 카메라.

As for claim 1, the video camera in which the image processing system is configured to manipulate image data mosaiced the furnace (raw) before compression in order to reduce the entropy of furnace (raw) image data.

청구 12항:

Claim 12:

제 1항에 있어서, 상기 이미지 프로세싱 시스템은 압축 이전으로(raw) 모자이크된 이미지 데이터의 엔트로피를 감소하기 위

As for claim 1, the video camera which is configured to reduce the entropy of image data in which the image p

해 구성되는 비디오 카메라.

청구 13항:

청구 14항:

청구 15항:

청구 16항:

청구 17항:

청구 18항:

청구 19항:

제1항에 있어서,라이트(light) 검출 디바이스는 베이어 센서를 포함하는 비디오 카메라.

청구 20항:

라이트(light)를 라이트(light) 검출 소자에 유도하는 단계;상기 라이트(light) 검출 소자에 의해 수신된 라이트(light)를 초당 23프레임보다 적어도 큰 비율에서 적어도 2k의 해상력을 가지는 적어도 제1, 제2 및 제3 컬러를 나타내는 로(raw) 모자이크된 디지털 이미지 데이터로 변형하는 단계;상기 로(raw) 디지털 이미지 데이터가 외형적으로는 무손실을 유지하도록 상기 로(raw) 모자이크된 디지털 이미지 데이터를 압축하는 단계; 및 스토리지 디바이스 상에 초당 적어도 23프레임의 비율 및 적어도 2k의 해상력으로 로(raw) 모자이크된 디지털 이미지 데이터를 저장하는 단계를 포함하고,상기 압축된 로(raw) 모자이크된 디지털 이미지 데이터는 본질적으로 외형적으로는 무손실을 유지하고, 하기 방법은 제1 평균 값을 획득하기 위해 상기 제1 컬러의 센서 셀에 인접한 적어도 네 개의 센서 셀로부터 상기 제3 컬러의 이미지 데이터의 평균 값을 계산하는 단계, 제2 평균 값을 획득하기 위해 상기 제2 컬러의 센서 셀에 인접한 적어도 네 개의 센서 셀로부터 상기 제3 컬러의 이미지 데이터의 평균 값을 계산하는 단계, 및 상기 제1 컬러의 상기 센서 셀로부터 상기 이미지 데이터의 값으로부터 상기 제1 평균 값을 공제하고 상기 제2 컬러의 상기 센서 셀로부터 상기 이미지 데이터의 값으로부터 상기 제2 평균 값을 공제함으로써 상기 이미지 데이터를 변경하는 단계를 포함하고, 상기 공제 후(following the subtraction) 상기 변경된 압축된 로(raw) 디지털 이미지 데이터는 상기 스토리지 디바이스 상에 저장되는,비디오를 이용한 동영상 저장방법.

청구 21항:

제 20항에 있어서, 상기 로(raw) 디지털 이미지 데이터를 압축하는 단계는적어도 6:1의 효과적인 압축 비율로 로(raw) 디지털 이미지 데이터를 압축하는 단계를 포함하는 비디오를 이용한 동영상 저장방법.

청구 22항:

rocessing system is mosaiced before compression the furnace (raw).

Claim 13:

Claim 14:

Claim 15:

Claim 16:

Claim 17:

Claim 18:

Claim 19:

As for claim 1, the video camera wherein the light detection device comprises the sensor it is cut.

Claim 20:

The step of inducing in the light detecting element the light, at least first and second and step of changing to digital image data, the step of compressing digital image data, and the storage device, per second, the rate of at least 23 frame and step are included ; and digital image data mosaiced the compacted furnace (raw) as described above essentially externally maintain the lossless, and at least first and second and step of changing to digital image data are mosaiced the furnace (raw) which shows third color the light received with the light detecting element the definition of at least 2k is per second gone than 23 frame from at least large rate; the step of compressing digital image data is mosaiced to (raw) in order to maintain; and the storage device, per second, the rate of at least 23 frame and step stores digital image data mosaiced to the definition (raw) of at least 2k. Video storage method using the video in which it includes ; and compacted furnace (raw) digital image data which the subtraction after (following the subtraction) the above is changed is stored on the storage device the step of calculating the average value of image data of the third color from the sensor cell of at least four adjacent to the sensor cell of the first color, and the step of calculating the average value of image data of the third color from the sensor cell and step of changing image data it subtracts of at least four below method obtains the first average value, and the step of calculating the average value of image data of the third color from the sensor cell and step of changing image data it subtracts of at least four is adjacent to the sensor cell of the second color in order to gain the second average value.

Claim 21:

As for claim 20, the video storage method using the video wherein the step of compressing (raw) digital image data comprises the step of compressing the effective compression ratio (raw) digital image data of at least 6:1.

Claim 22:

제 20항에 있어서, 상기 로(raw) 이미지 데이터를 압축하는 단계는 적어도 12:1의 효과적인 압축 비율로 로(raw) 디지털 이미지 데이터를 압축하는 단계를 포함하는 비디오를 이용한 동영상 저장방법.

청구 23항:

청구 24항:

제 20항에 있어서, 상기 저장하는 단계는 압축된 로(raw) 모자이크된 디지털 이미지 데이터를 저장하는 단계를 포함하는 비디오를 이용한 동영상 저장방법.

청구 25항:

제 20항에 있어서, 상기 저장하는 단계는 스토리지 디바이스에 초당 적어도 23.976의 비율로 로(raw) 모자이크된 디지털 이미지 데이터를 저장하는 단계를 포함하는 비디오를 이용한 동영상 저장방법.

청구 26항:

제 20항에 있어서, 상기 저장하는 단계 이전으로(raw) 모자이크된 디지털 이미지 데이터의 엔트로피를 감소하기 위해 로(raw) 이미지 데이터를 조작하는 단계를 더 포함하는 비디오를 이용한 동영상 저장방법.

청구 27항:

제 20항에 있어서, 상기 저장하는 단계 이전으로(raw) 모자이크된 디지털 이미지 데이터의 엔트로피를 감소하기 위한 단계를 더 포함하는 비디오를 이용한 동영상 저장방법.

청구 28항:

제 27항에 있어서, 상기 엔트로피를 감소하는 단계 이후에 외형적으로 손실 없는 방법으로 로(raw) 모자이크된 디지털 이미지 데이터를 압축하는 단계를 더 포함하는 비디오를 이용한 동영상 저장방법.

청구 29항:

청구 30항:

제 20항에 있어서, 상기 저장하는 단계는 변환 단계를 위해 사용된 라이트(light) 감출 소자를 포함하는 카메라상에 압축된 데이터를 저장하는 단계를 포함하는 비디오를 이용한 동영상 저장방법.

청구 31항:

제 20항에 있어서, 상기 제 3 이미지 데이터의 반을 삭제하는 단계를 더 포함하는 비디오를 이용한 동영상 저장방법.

청구 32항:

청구 33항:

As for claim 20, the video storage method using the video wherein the step of compressing (raw) image data comprises the step of compressing the effective compression ratio (raw) digital image data of at least 12:1.

Claim 23:

Claim 24:

As for claim 20, the video storage method using the video wherein the step storing as described above comprises the step which stores digital image data mosaic d the compacted furnace (raw).

Claim 25:

As for claim 20, the video storage method using the video wherein the step storing as described above comprises the storage device, per second, the step which stores mosaiced digital image data at a ratio of at least 23.976 (raw).

Claim 26:

As for claim 20, the video storage method using the video further comprising the step of manipulating furnace (raw) image data it reduces in the before step (raw) stored as described above.

Claim 27:

As for claim 20, the video storage method using the video further comprising the step for reducing the entropy of mosaiced digital image data in the before step (raw) stored as described above.

Claim 28:

As for claim 27, the video storage method using the video further comprising the step of compressing digital image data which are mosaiced to the method (raw) which there is no to the step Lee HuE outer shape with loss reduces entropy.

Claim 29:

Claim 30:

As for claim 20, the video storage method using the video included the step which stores data compacted on the camera wherein the step storing as described above comprises the light detecting element used for the conversion step.

Claim 31:

As for claim 20, the video storage method using the video further comprising the step of deleting the half of third image data.

Claim 32:

Claim 33:

청구 34항:

제20항에 있어서,상기 이미지 데이터는 그린 이미지 데이터를 나타내는 비디오를 이용한 동영상 저장방법.

Claim 34:

As for claim 20, the video storage method using the video showing image data which image data draws.

청구 35항:

제20항에 있어서,상기 압축된 로(raw) 모자이크된 디지털 이미지 데이터와 변형된 제 1 및 제 2 이미지 데이터를 압축해제하는 단계를 더 포함하는 비디오를 이용한 동영상 저장방법.

Claim 35:

As for claim 20, the video storage method using the video further comprising the compacted furnace (raw) as described above the step of compression-releasing first and second image data changed with mosaiced digital image data.

청구 36항:

제 35항에 있어서,상기 압축해제된 디지털 이미지 데이터를 디모자이크하는 단계를 더 포함하는 비디오를 이용한 동영상 저장방법.

Claim 36:

As for claim 35, the video storage method using the video further comprising the demosaic is the step the compression-released digital image data as described above.

청구 37항:

Claim 37:

청구 38항:

Claim 38:

청구 39항:

Claim 39:

청구 40항:

Claim 40:

하우징에 의해 지지되고, 라이트(light)를 포커싱 하기 위해 구성된 렌즈 어셈블리;포커싱된 라이트(light)를, 포커싱된 라이트(light)를 나타내고 적어도 2k의 해상력을 가지는 적어도 제 1, 제2 및 제3 컬러를 나타내는 로(raw) 모자이크된 이미지 데이터의 신호로 변환하기 위해 구성된 라이트(light) 검출 디바이스;메모리 디바이스; 및압축해제시 상기 로(raw) 이미지 데이터가 외형적으로는 무손실을 유지하도록, 초당 적어도 23 프레임의 프레임 비율(frame rate)로 로(raw) 모자이크된 이미지 데이터를 상기 메모리 디바이스에 압축하고 저장하기 위한 수단을 포함하고,상기 압축된 로(raw) 모자이크된 디지털 이미지 데이터는 본질적으로 외형적으로는 무손실을 유지하고, 압축하고 저장하기 위한 수단은 제1 평균 값을 획득하기 위해 상기 제1 컬러의 센서 셀에 인접한 적어도 네 개의 센서 셀로부터 상기 제3 컬러의 이미지 데이터의 평균 값을 계산하고, 제2 평균 값을 획득하기 위해 상기 제2 컬러의 센서 셀에 인접한 적어도 네 개의 센서 셀로부터 상기 제3 컬러의 이미지 데이터의 평균 값을 계산하며, 상기 제1 컬러의 상기 센서 셀로부터 상기 이미지 데이터의 값으로부터 상기 제1 평균 값을 공제하고 상기 제2 컬러의 상기 센서 셀로부터 상기 이미지 데이터의 값으로부터 상기 제2 평균 값을 공제함으로써 상기 이미지 데이터를 변경하도록 구성되며, 상기 공제 후(following the subtraction) 상기 변경된 압축된 로(raw) 디지털 이미지 데이터는 스토리지 디바이스 상에 저장되는,비디오 카메라.

The lens assembly, the light detection device, memory device, and the means image data externally maintain the lossless with (raw) in decompression ; and for compressing and storing image data per second mosaiced to the frame rate (frame rate) (raw) of at least 23 frame in the memory device are included with housing ; digital image data mosaiced the compacted furnace (raw) as described above essentially externally maintain the lossless ; so that the means for compressing and storing obtain the first average value the average value of image data of the third color is calculated from the sensor cell of at least four adjacent to the sensor cell of the first color ; and the average value of image data of the third color is calculated from the sensor cell of at least four adjacent to the sensor cell of the second color in order to gain the second average value, and the lens assembly is supported ; and is configured to focus the light; and the light detection device is configured to show the light which is the focused light focused and which it is configured to convert into the signal of image data mosaiced the furnace (raw) showing at least first and second and the third color to go to the definition of at least 2k. The video camera in which it is configured to subtract the first average value from the sensor cell of the first color from the value of image data and it change image data from the sensor cell of the second color by subtracting the second average value from the value of image data ; and compacted furnace (raw) digital image data which the subtraction after (following the subtraction) the above is changed is stored on the storage device.

청구 41항:

Claim 41:

청구 42항:

Claim 42:

청구 43항:

Claim 43:

기술분야

본 발명은 정지 또는 동영상을 캡처하기 위한 것들과 같은 디지털 카메라, 특히, 이미지를 압축하는 디지털 카메라와 같은 디지털 카메라에 관련된 것이다.

배경기술

디지털 비디오 카메라의 유용성에도 불구하고, 주요한 동영상 제작자들과 몇몇 텔레비전 브로드캐스트 미디어는 필름 카메라에 계속하여 의존한다. 그러한 것을 위해 사용되는 필름은 비디오 에디터에게 대체 수단에 의해 편집될 수 있는 매우 고성능의 해상도 이미지를 제공한다. 그러나 최근에는 그러한 필름이 종종 스캔되거나 디지털화 및 디지털 적으로 편집된다.

상세설명

현재 이용가능한 몇몇 디지털 비디오 카메라는 고해상도 이미지 센서를 포함하고, 따라서 고 해상도 비디오를 출력하며, 그러한 카메라상에 사용되는 이미지 프로세싱 및 압축 기술은 너무 손실이 많아서, 상기에서 언급된 시장의 하이 엔드 부분들에서 허용되기에 너무나 많은 로(raw) 이미지 데이터가 제거된다. 여기에서 개시된 적어도 하나의 실시예의 관점은 메이저 동영상 시장과 같은 상기에서 주목된 시장의 하이 엔드 부분들을 위해 허용될 수 있는 비디오 질이 초당 적어도 약 23프레임의 프레임 비율과 적어도 약 2K의 해상도를 가지는 로(raw) 또는 본질적인 로(raw) 이미지 데이터를 캡처하고 저장할 수 있는 카메라에 의해 만족되는 구현을 포함한다.

따라서, 실시예에 따라, 비디오 카메라는 포터블 하우징 (portable housing) 및 하우징(housing)에 의해 지지되고 렌즈를 포커싱 하기 위해 구성된 렌즈 어셈블리(lens assembly)를 포함할 수 있다. 라이트 검출 디바이스(light sensitive device)는 포커싱된 라이트를 초당 적어도 약 23프레임의 프레임 비율로, 적어도 2K의 해상도를 가지는 로(raw) 이미지 데이터로 변환하기 위해 구성될 수 있다.

카메라는 적어도 6:1의 압축비와 외형적으로 손실 없이 존재하고, 초당 약 23프레임의 비율로 로(raw) 이미지 데이터를 메모리 디바이스(memory device)에 압축하고 저장하기 위해 구성된 이미지 프로세싱 시스템(image processing system)과 메모리 디바이스(memory device)를 또한 포함할 수 있다.

다른 실시예에 따르면, 카메라를 이용한 동영상을 저장하는 방법은 광 검출 디바이스상(light sensitive device)에 라이트를 유도하는 단계를 포함할 수 있다. 상기 방법은 라이트 검출 소자에 의해 수신된 라이트를 초당 23프레임보다 적어도 더 큰 비율로 로(raw) 이미지 데이터를 변환하는 단계, 상기 로(raw) 이미지 디지털 이미지 데이터를 압축하는 단계 및 스토리지 디바이스(storage device)상에 초당 적어도 약 23프레임의 비율로 로(raw) 이미지 데이터를 저장하는 단계를 또한 포함할 수 있다.

Technical Field

It relates to the digital camera like in which the invention captures the pause or the moving picture, and the digital camera like the digital camera narrowing down especially, the image.

Background Art

And then, and then, important moving picture production person and the some television broadcast medias depend on the film camera in spite of the utility of the digital video camera. The film used for those provides the video editor with the resolution of the highly efficient which can be edited with alternative means is the image. But recently, that film is scanned on the often or it is edited to the digitalization and digital.

Detailed Description

Presently, the available some digital video camera includes the high resolution image sensor. Therefore the high-resolution outputs the video. And the image processing and the compression technology used on that camera there are many loss. Very many furnace (raw) image data is removed to be allowed in high end parts of the market which in the above case, is mentioned. Here, the point of view of the embodiment of the disclosed at least one comprises the video quality which can be allowed for high end parts of the market which in the above case, is watched like the major moving picture market which is the implementation satisfied with the camera which can capture the furnace (raw) having the resolution or intrinsic furnace (raw) image data of at least about 2K and can store with the frame rate of per second, at least about 23 frame.

Therefore, the video camera according to the embodiment comprises the portable housing and the lens assembly which is configured to be supported by the housing and focus light. The light in which the light detection device (light sensitive device) is focused is configured to be per second converted into the frame rate of at least about 23 frame into the furnace (raw) image data having the resolution of at least 2K.

The camera externally exists with the compression ratio of at least 6:1 without the loss. The image processing system and the memory device which is configured to compress and per second store image data in the memory device at a ratio of about 23 frame (raw) are included might moreover.

The step of inducing the method for storing is the light in the light detection device phase (light sensitive device) is include might. Step which stores image data is include might per second per second moreover than 23 frame to at least greater rate (raw) on the step of converting image data, and the step of compressing (raw) image digital image data and storage device at a ratio of at least about 23 frame (raw) the method is received with the light detecting element.

또 다른 실시예에 따르면, 비디오 카메라는 하우징(housing)에 의해 지지되고 렌즈를 포커싱 하기 위한 렌즈 어셈블리(lens assembly)와 포커싱된 렌즈를 포커싱된 렌즈를 나타내는 로(raw) 이미지 데이터의 시그널로 변환하기 위한 렌즈 감출 디바이스(light sensitive device)를 포함할 수 있다. 카메라는 메모리 디바이스(memory device)와, 초당 적어도 약 23프레임의 비율로 로(raw) 이미지 데이터를 압축하고 저장하기 위한 수단(means)을 또한 포함할 수 있다.

또 다른 실시예에 따르면, 비디오 카메라는 카메라의 비디오 녹화 동작 동안 사용자가 하우징의 움직임의 적어도 하나의 각도에 관련한 방향을 조작 가능하도록 구성된 적어도 하나의 핸들을 가지는 포터블 하우징(portable housing)을 포함할 수 있다. 렌즈 어셈블리(lens assembly)는 하우징(housing)에 의해 지지되고 상기 하우징(housing) 내부에 배열된 면에 렌즈를 포커싱 하기 위해 구성된 적어도 하나의 렌즈를 포함할 수 있다. 렌즈 감출 디바이스(light sensitive device)는 포커싱된 렌즈를 적어도 2K의 수평 해상도와 적어도 약 초당 23프레임의 프레임 비율을 가지는 로(raw) 이미지 데이터로 변환하기 위해 구성될 수 있다. 메모리 디바이스(memory device)는 비디오 이미지 데이터를 저장하기 위해 구성될 수 있다. 이미지 프로세싱 시스템(image processing system)은 적어도 6:1의 압축비와 외형적으로는 손실 없고, 초당 적어도 약 23프레임의 비율로 로(raw) 이미지 데이터를 메모리 디바이스에 압축하고 저장하기 위해 구성될 수 있다.

여기에서 개시된 본 발명의 적어도 하나의 다른 면은, 인간의 눈은 어떠한 다른 컬러보다 그린 파장에 매우 민감하기 때문에, 이미지 센서에서 출력되는 이미지 데이터의 변경에 기초한 그린 이미지 데이터가 데이터의 압축력을 향상시키기 위해 사용될 수 있고, 높은 질의 비디오 이미지를 제공한다. 그러한 기술은 데이터 압축 이전에 감출된 레드 및/또는 블루 렌즈의 크기에서 감출된 그린 렌즈의 크기를 공제하는 단계를 포함할 수 있다. 이것은 레드 및/또는 블루 이미지 데이터를 더 많은 압축 가능한 형태로 변환할 수 있다. 예를 들어서, 감마 수정된 RGB 데이터를 Y#39#CbCr로 변환하기 위한 알려진 프로세스에서, 이미지는 #34#비상관(decorrelated)#34#되고, Y#39#(루마(luma)라고 알려진)에서 대부분의 이미지 데이터가 남으며, 그것으로서 잔여 크로마 컴포넌트들은 더욱 압축적이다. 그러나 Y#39#CrCb 포맷으로 변환하기 위한 알려진 기술은 베이어 패턴 필터(Bayer pattern filter)에 바로 적용될 수 없는데, 그 이유는 각각의 컬러 데이터가 공간적으로 상관되지 않고, 베이어 패턴 필터(Bayer pattern filter)는 블루 또는 레드 이미지 데이터보다 두 배 많은 그린 이미지 데이터를 포함하기 때문이다. 여기에서 개시된 어떠한 실시예에 따르면, 그린 이미지 데이터 공제(subtraction) 단계는 이미지 데이터의 대부분이 그린 이미지 데이터에 남아있고, 잔여 데이터(remaining data)는 더욱 압축력 있는 형태로 남아 있다는 점에서 상기 주목한 Y#39#CbCr 변환에 유사할 수 있다.

게다가, 그린 이미지 데이터 공제(subtraction) 단계는 가역적일 수 있고, 모든 오리지널 로(raw) 데이터를 보존할 수 있다. 따라서, 그러한 기술을 이용한 결과 시스템 및 방법은 손실 없거나 외형적으로 손실이 없고 그러한 비디오 이미지 데이터의 향상된 압축력을 제공할 수 있다.

And the video camera it is different in the other embodiment comprises the lens assembly for being supported by the housing and focusing light and the light detection device (light sensitive device) for converting the he focused light into the signal of computer of furnace (raw) image data showing the focused light. And the camera moreover may include the memory device, and the means for per second compressing image data at a ratio of at least about 23 frame (raw) and storing.

And the video camera according to the other embodiment may include the portable housing in which the user has at least one handle which is configured to manipulate the direction relating to at least one angle of the movement of housing for the video recording operation of the camera. The lens assembly may include at least one lens which is configured to focus light in the side which is supported by the housing and is arranged inside the housing. The light in which the light detection device (light sensitive device) is focused is configured to be converted into the furnace (raw) image data having the horizontal resolution, at least, the , per second, the frame rate of 23 frame of at least 2K. The memory device is configured to store video image data. There is externally no image processing system with the compression ratio of at least 6:1 with loss. It is configured to compress and image data are configured to be per second stored in the memory device at a ratio of at least about 23 frame (raw).

Here, so that image data drawn based on the image data change outputted from the image sensor it is very sensitive to the wavelength drawn improve the compressive force of data than the other color the eye of human can be used. It provides the video image of the high quality. That technology may include the step of subtracting the size of the green light detected from the size of the red previously detected with compression of data and/or the blue light. This can convert red and/or blue image data into more form enabling to compress. The example is given. It becomes the image in the known process for converting gamma-corrected RGB data into the YCbCr with the " uncorrelated (decorrelated) ". Most of image datas remain in the Y#39 # (it is known as the luma). And residual chroma components are more compressive as that. But in the known technology for converting into the YCrCb format, reason for the is each RGB it cannot be immediately applied to the bayer pattern filter includes image data in which the bayer pattern filter is more than blue or red image data with the twice it is not spatially related drawn. Here, according to the disclosed any embodiment, it remains in image data drawn by the image data subtraction step drawn is the majority of image data. The has with compressive force form can be similar in the YCbCr conversion paid attention as described above in that the remaining data more remains as the form which.

Moreover, the image data subtraction step drawn can be reversible. Data can be preserved at all original (raw). Therefore, as a result of using that technology it there is no with loss or there can be no loss and system and method can provide the improved compressive force of that video image data.

따라서, 실시예에 따르면, 비디오 카메라는 하우징에 의해 지지되고, 렌즈를 포커싱 하기 위해 구성된 렌즈 어셈블리(lens assembly)와, 포커싱 된 렌즈를 적어도 제 1, 제2 및 제3의 포커싱된 컬러로 나타내는 이미지 데이터의 로(raw) 시그널로 변환하기 위한 렌즈 감출 디바이스(light sensitive device)를 포함할 수 있다. 이미지 프로세싱 모듈(image processing module)은 상기 제 3컬러의 이미지 데이터에 기초한 적어도 하나의 제 1 및 제 2컬러의 이미지 데이터를 변경하기 위해 구성될 수 있다. 게다가 비디오 카메라는 메모리 디바이스(memory device) 및 제 1, 제 2 및 제 3컬러의 이미지를 압축하고, 초당 적어도 약 23프레임의 프레임 비율로 이미지 데이터를 메모리 디바이스(memory device)에 압축된 이미지 데이터를 저장하기 위해 구성된 압축 디바이스(compression device)를 포함할 수 있다.

다른 실시예에 따르면, 이미지를 프로세싱 방법이 제공될 수 있다. 방법은 이미지 및 을 제 1컬러를 나타내는 로(raw) 제 1 이미지 데이터, 제 2컬러를 나타내는 로(raw) 제 2 이미지 데이터, 및 제 3컬러를 나타내는 로(raw) 제 3 이미지 데이터로 변환하는 단계와, 상기 로(raw) 제 3 이미지 데이터에 기초한 적어도 로(raw) 제 1 이미지 데이터 및 로(raw) 제 2 이미지 데이터를 변경하는 단계와, 로(raw) 제 3 이미지 데이터와 변경된 로(raw) 제 1 및 로(raw) 제 2 이미지 데이터를 압축하는 단계; 및 압축된 데이터를 저장하는 단계를 포함할 수 있다.

또 다른 실시예에 따르면, 비디오 카메라는 하우징에 의해 지지되고, 렌즈를 포커싱 하기 위해 구성된 렌즈 어셈블리(lens assembly)를 포함할 수 있다. 렌즈 감출 디바이스(light sensitive device)는 포커싱 된 렌즈를 적어도 제 1, 제2 및 제3의 포커싱된 컬러로 나타내는 이미지 데이터의 로(raw) 시그널로 변환하기 위해 구성될 수 있다. 카메라는 상기 제 3컬러의 이미지 데이터에 기초한 적어도 하나의 제 1 및 제 2컬러의 이미지 데이터를 변경하기 위한 수단(means), 메모리 디바이스(memory device); 및 제 1, 제 2 및 제 3컬러의 이미지를 압축하고, 메모리 디바이스 상에 압축된 이미지 데이터를 저장하기 위해 구성된 압축 디바이스(compression device)를 포함할 수 있다.

산업상 이용 가능성

레드 및 블루 이미지 데이터를 재구성하기 이전에 그린 이미지 데이터를 디모자이크 하는 것에 의해서, 어떠한 다른 이점이 수행될 수 있다. 예를 들어서, 상기에서 주목한 것처럼, 인간의 눈은 그린 광에 더욱 민감하다. 그린 이미지 데이터를 디모자이크하고 프로세싱하는 것은 인간의 눈이 더욱 민감한 그린 이미지 값을 최적화하는 것이다. 따라서, 레드 및 블루 이미지 데이터의 연속적인 재구성은 그린 이미지 데이터의 프로세싱에 의해 영향을 받을 수 있다.

게다가, 베이어 패턴은 레드 및 블루 엘리먼트들 보다 두 배의 그린 엘리먼트를 가진다. 이와 같이, 모든 그린 데이터가 유지되는 실시예들에서는, 레드 또는 블루 이미지 데이터 엘리먼트들 중 하나와 비교하여 두 배의 그린 엘리먼트를 위한 이미지 데이터가 존재한다. 따라서, 디모자이크 기술, 필터 및 다른 이미지 프로세싱 기술은 더 나은 디모자이크, 샤프 또는 다른 필

Therefore, according to a preferred embodiment of the present invention, the video camera comprises at least first the lens assembly, which is configured to focus light it is supported by housing and the focused light, and the second and the light detection device (light sensitive device) for converting into the image data (raw) shown in terms of the third focused color into the signal of computer. And the image processing module comprises moreover, the video camera is the memory device image data of at least one first and second color based on image data of the third color is configured to be changed and per second, the compression device which stores image data which is image data compacted to the frame rate in the memory device of at least about 23 frame the first, and the image of the second and the third color are narrowed down.

Provided is the processing method the image according to the other embodiment. The step of converting furnace (raw) second image data and the third color shown into furnace (raw) third image data shown, the step of changing the little drawing (raw) which it is based on third image data to (raw) first image data and furnace (raw) second image data, and the step of compressing furnace (raw) third image data and furnace (raw) first and changed furnace (raw) second image data and step which stores compacted data are include might.

And the video camera according to the other embodiment comprises at least first the light which is supported by housing and the lens assembly which is configured to focus light is include might in which the light detection device (light sensitive device) is focused., and the second and the compression device which stores image data narrowing down the means, for changing image data the memory device: and the first, and the image of the second and the third color and is compacted on the memory device of at least one first and second color which it is configured to convert into the signal of computer the camera is based on image data of the third color to the image data (raw) shown in terms of the third focused color.

Industrial Availability

Image data which it draws before reconstructing red and blue image data are done with demosaic. Accordingly the other advantage can be performed. The example is given. In the above case, as it pays attention. The eye of human is more sensitive to the green light. The image value in which the eye of human is more sensitive drawn is optimized to process image data drawn with the demosaic. Therefore, it can be influenced with the processing of image data which the successive reconfiguration of blue image data and red draws.

Moreover, the bayer pattern has the element drawn than red and blue elements with double. In this way, when compared with one among red or blue image data elements in the embodiment, in which data drawing are maintained, image data for the element drawn with double exists. Therefore, the demosaic in which the demos

터된 이미지의 결과를 제공한다. 레드 및 블루 이미지 데이터를 재구성하고 디모자이크 하기 위해 이러한 디모자이크된 값들을 사용하는 것은 프로세스, 재구성, 및 레드 및 블루 엘리먼트들의 디모자이크의 고 해상도와 연관된 이점을 전달한다. 그것으로서, 결과 이미지는 더욱더 향상된다.

도면에 대한 간단한 설명

도 1은 실시예에 따른 하드웨어를 포함할 수 있고/있거나 비디오 이미지 데이터를 프로세싱하기 위한 방법을 수행하도록 구성되는 시스템을 도시화한 블록도이다.

도 2는 도 1에 개략적으로 도시된 카메라를 위한하우징의 임의의 실시예이다.

도 3은 도 1에 도시된 시스템을 사용할 수 있는 베이어 패턴 필터(Bayer Pattern Filter)를 가지는 이미지 센서의 개략적인 레이아웃이다.

도 4는 도 1에 도시된 시스템에서 사용될 수 있는 이미지 프로세싱 모듈의 개략적인 블록 다이어그램이다.

도 5는 도 3의 이미지 센서의 그린(green) 센서 셀에서의 그린 이미지 데이터의 개략적인 레이아웃이다.

도 6은 수개의 오리지널 그린 이미지 데이터의 선택적 삭제 프로세스 후 남은 도 5의 그린 이미지 데이터의 개략적인 레이아웃이다.

도 7은 도 1의 이미지 프로세싱 모듈에서 프로세싱을 위해 조직된 도 5의 레드(red), 블루(blue) 및 그린(green) 이미지 데이터의 개략적인 레이아웃이다.

도 8은 도 1에 도시된 시스템을 가지고 사용될 수 있는 이미지 변환(transformation) 기술을 도시한 플로어차트이다.

도 8A는 도 1에 도시된 시스템을 가지고 또한 사용될 수 있는 도 8의 이미지 데이터 변환 기술의 변경(modification)을 도시한 플로어 차트이다.

도 9는 도 8의 이미지 변환 프로세스의 결과인 블루 이미지 데이터의 개략적인 레이아웃이다.

도 10은 도 8의 이미지 변환 프로세스의 결과인 레드 이미지 데이터의 개략적인 레이아웃이다.

도 11은 감마 수정을 위해 이미지 데이터에 적용될 수 있는 대표적인 선택 변환을 도시한 것이다.

도 12는 이미지 데이터를 압축해제하고 디모자이크(demosaic) 하기 위한 도 1의 시스템을 가지고 사용될 수 있는 제어 루틴의 플로어 차트이다.

도 12A는 도 1에 도시된 시스템을 가지고 또한 사용될 수 있는 도 12의 제어 루틴의 변경을 도시한 플로어 차트이다.

도 13은 도 12의 플로어차트에 따른 압축해제되고 디모자이크된 그린 이미지의 개략적인 레이아웃이다.

도 14는 도 12의 플로어차트에 따른 압축해제되고 디모자이크된 도 13에서의 오리지널 그린 이미지 데이터의 반의 개략적인 레이아웃이다.

도 15는 도 12의 플로어차트에 따른 압축해제된 블루 이미지 데이터의 개략적인 레이아웃이다.

도 16은 도 12의 플로어차트에 따라 디모자이크된 도 15의 블루 이미지 데이터의 개략적인 레이아웃이다.

aic technology, filter, and other image processing technology are more better, and the result of the sharpen or the other filtered image are offered concerning. It processes to be to reconstruct red and blue image data and do and use demosaiced such values. The advantage related to the high resolution of the demosaic of the re configuration and red and blue elements is delivered. As that, the resultant image is more and more improved.

Brief explanation of the drawing

Figure 1 is a block diagram urbanizing the system performing the method for maying include hardware and having or processing video image data according to the embodiment.

Figure 2 is an arbitrary embodiment of the housing for the camera shown in fig. 1.

The system in which fig. 3 is illustrated in 1 may be referred to the summary layout of the image sensor having the bayer pattern filter can use.

Figure 4 is a summary block diagram of the image processing module which can be used in the system illustrated in Figure 1.

Figure 5 is a summary layout of image data drawn at the green sensor cell of the image sensor of fig. 3.

Figure 6 is a summary layout of image data remaining after the selective erasure process of image data drawn original drawn of fig. 5 of the number.

In fig. 7 is the image processing module of 1, it is the red composed for the processing of fig. 5, and the summary layout of green image data and blue.

The system in which fig. 8 is illustrated in 1 may be referred to the flow chart showing the image conversion (transformation) technology having and be used.

Figure 8A is a flow chart showing the change (modification) of the image data diversion technique which can be moreover used having the system illustrated in Figure 1 of fig. 8.

Figure 9 is a summary layout of the blue image data called the result of the image conversion process of fig. 8.

It is the summary layout of the red image data called fig. 10 is the result of the image conversion process of 8.

Figure 11 shows the representative selective change which can be applied to image data for the gamma correction.

Figure 12 is a flow chart of the control routine which can be used having the system of the demosaic below *** drawing 1 image data are compression-released.

Figure 12A is a flow chart showing the change of the control routine which can be moreover used having the system illustrated in Figure 1 of fig. 12.

Fig. 13 is the summary layout which compression-released is demosaiced drawn of the image according to the flow chart of 12.

Figure 14 is a summary layout of the half of image data drawn the original which is demosaiced it is compression-released in fig. 13 according to the flow chart of fig. 12.

Figure 15 is a summary layout of compression-released blue image data according to the flow chart of fig. 12.

It is the summary layout of blue image data in which fig. 16 is demosaiced according to the flow chart of 12 of fig. 15.

실시예

도 1은 동영상 촬영을 위한 비디오 카메라와 관련하여 묘사된, 이미지 센싱(image sensing), 프로세싱(processing) 및 압축 모듈(compression module)을 가지는 카메라의 개략적인 다이어그램이다. 여기에서 개시된 실시예는 베이어 패턴(Bayer pattern)을 가지는 싱글 센서 디바이스를 가지는 비디오 카메라와 관련하여 묘사되는데, 그 이유는 이러한 실시예들은 이와 관련된 특별한 유용성을 가지기 때문이다. 그러나 여기에서의 실시예와 발명들은 다른 형태의 이미지 센서(예를 들어, CMY 베이어 및 다른 비-베이어 패턴)와 다른 이미지 포맷 형태상에서 작동되고, 정지영상 및/또는 동영상을 위해 구성된 다른 수개의 이미지 센서를 가지는 카메라들에도 또한 적용될 수 있다. 이와 같이, 여기서 개시된 실시예들은 대표적이거나 제한되지 않은 실시예들임은 이해할 수 있으며, 따라서, 여기에서 개시된 발명들은 개시된 대표 실시예들에 의해서 제한되지 않는다.

도 1에 연속하여, 카메라 10은 비디오 이미지 데이터를 검색, 처리 및 선택적으로 저장 및/또는 재생하기 위해 구성된 시스템 14를 지지하기 위해 형성된 바디(body) 또는 하우징(housing) 12를 포함한다. 예를 들어, 상기 시스템 14는 옵틱 하드웨어 16(optics hardware), 이미지 센서(image sensor) 18, 이미지 프로세싱 모듈(image processing module) 20, 압축모듈(compression module) 22 및 스토리지 디바이스(storage device) 24를 포함할 수 있다. 선택적으로, 카메라 10은 모니터 모듈(monitor module) 26, 플레이 백 모듈(play back module) 28 및 디스플레이(display) 30을 또한 포함할 수 있다.

도 2는 카메라 10의 제한되지 않은 대표적인 실시예를 도시하였다. 도 2에서 보여지는 바와 같이, 옵틱 하드웨어(optics hardware) 16은 어느 정도 그것의 외부 표면에서 노출되도록 하는 하우징(housing) 12에 의해 지지될 수 있다. 어떤 실시예들에서, 상기 시스템 14는 하우징(housing) 12 내에서 지지될 수 있다. 예를 들어, 이미지 센서(image sensor) 18, 이미지 프로세싱 모듈(image processing module) 20 및 압축 모듈(compression module) 22는 하우징(housing) 12 내에서 수용될 수 있다. 스토리지 디바이스(storage device) 24는 하우징 12에 마운트 될 수 있다. 부가적으로, 어떤 실시예들에서는, 스토리지 디바이스(storage device) 24는 하우징(housing) 12의 외부에 마운트 될 수 있고, 어떠한 형태의 커넥터 또는 케이블을 통하여 상기 시스템 14의 잔여 부분에 연결될 수 있다. 부가적으로, 스토리지 디바이스(storage device) 24는 신축 케이블을 가지고 상기 하우징 12에 연결될 수 있고, 따라서, 상기 스토리지 디바이스(storage device) 24가 하우징 12에서 다소 독립적으로 이동 가능하도록 한다. 예를 들어, 그러한 신축 케이블 접속을 이용하여, 상기 스토리지 디바이스(storage device) 24는 사용자의 벨트 상에서 휴대 될 수 있고, 상기 하우징 12의 총 무게가 감소되는 것을 가

Example(s)

Figure 1 is a summary diagram of the camera having the image sensing depicted in connection with the video camera for the moving picture, and the processing and compressive module (compression module). Here, the disclosed embodiment is the bayer pattern may be referred to reason for the this embodiments is the device configuration because the special utility associated with this it is depicted in connection with the video camera having the single sensor device had. But it is operated on the embodiment at the activating and image format different from the invention is the image sensor (the specific- bayer pattern different from the CMY Bayer the example is given) of the other form. The embodiment can be applied to for the static images and/or the moving picture to the cameras having the image sensor of the comprised other number. In this way, it can understood to be the embodiment which is not limited. And the embodiment disclosed herein representatives therefore here the disclosed inventions is not limited by the disclosed representative execution examples.

Fig. 1 the , successively, the camera 10 comprises the processing video image data is searched and the body or the housing 12 which is formed in order to selectively support the system 14 which is configured to reproduce and/or storage. The system 14 the example is given comprises the optic hardware 16 (optics hardware), the image sensor 18, the image processing module 20, the compressive module (compression module) 22 and the storage device 24. Selectively, the camera 10 moreover may include the monitor module 26, and the play back module 28 and display 30.

Figure 2 shows the limited and representative embodiment of the camera 10. As shown in it seems to stand fig. 2 the optic hardware (optics hardware) 16 can be to some extent supported by the exposed housing 12 in its the outer surface. In certain embodiments, the system 14 can be supported in the housing 12. The example is given. The image sensor (image sensor) 18 , and the image processing module (image processing module) 20 and compressive module (compression module) 22 can be admitted in the housing 12. The storage device 24 can be mounted in the housing 12. Additionally, in certain embodiments, the storage device 24 can be mounted outside the housing 12. It can be connected to the remainder of the system 14 through the connector or the cable of any form. Additionally, the storage device 24 can have expansion and contraction cable and it can be attached to the housing 12. Therefore the storage device 24 is a bit independently mobile on the housing 12. The example is given. The storage device 24 can be carried along using such expansion and contraction cable splice on the belt of the user. It makes it p

능하게 한다. 또한, 다른 실시예들에서, 상기 하우징은 적어도 하나 이상의 스토리지 디바이스(storage device) 24를 내부에 포함할 수 있고, 그것의 외부에 마운트 될 수 있다. 게다가, 상기 하우징 12는 상기 모니터 모듈(monitor module) 26 및 플레이 백 모듈(play back module) 28을 지지하기 위해 제공될 수 있다. 또한, 어떤 실시예들에서는, 상기 디스플레이(display) 30은 하우징 12의 외부에 마운트(mount) 되도록 구성될 수 있다.

상기 옵틱 하드웨어(optics hardware) 16은 유입되는 이미지를 상기 이미지 센서(image sensor) 18위에 포커스 하기 위해서 구성된 적어도 하나의 렌즈를 가지는 렌즈 시스템의 형태로 존재할 수 있다. 선택적으로, 상기 옵틱 하드웨어(optics hardware) 16은 다양한 줌, 조리개(aperture) 및 포커스를 제공하는 멀티렌즈 시스템의 형태로 존재할 수도 있다. 게다가, 옵틱 하드웨어(optics hardware) 16은 하우징 12에 의해서 지지되고, 예를 들어서, 한정되지는 않으나, 옵틱 하드웨어(optics hardware) 16은 50-100mm(F2.8) 줌렌즈, 18-50 mm(F2.8) 줌 렌즈, 300mm(F2.8) 줌렌즈, 15 mm(F2.8) 렌즈, 25mm(F1.9) 렌즈, 35mm(F1.9)렌즈, 50mm(F1.9)렌즈, 85mm(F1.9) 렌즈 및/또는 다른 렌즈를 포함하는 다양한 사이즈의 렌즈 시스템들을 수용하도록 구성된 소켓을 포함하는 복수의 다른 형태의 렌즈 시스템을 수용하기 위해 구성되는 렌즈 소켓의 형태로 존재할 수 있다. 상기에서 주목한 것처럼, 옵틱 하드웨어(optics hardware) 16은 어떠한 렌즈가 그곳에 부착됨에도 불구하고, 이미지들이 이미지 센서(image sensor) 18의 라이트 검출 표면에 포커스 될 수 있도록 구성된다.

이미지 센서(image sensor) 18은 어떠한 형태의 비디오 센서 디바이스가 될 수 있는데, 예를 들어서, 한정되는 것은 아니나, CCD, CMOS, Foveon?? 센서, 또는 센서들 사이에 빛을 분할하기 위해 프리즘을 사용하는 멀티 센서 어레이와 같은 수직형-스택(vertically-stacked) CMOS 디바이스를 포함할 수 있다. 어떠한 실시예들에서는, 상기 이미지 센서 18은 약 1200만 포토셀을 가지는 CMOS 디바이스를 포함할 수 있다. 그러나 다른 사이즈의 센서도 사용될 수 있다. 어떠한 구성들에서는, 카메라 10은 #34#2K#34#(예를 들어, 2048 x 1152 픽셀), #34#4K#34#(예를 들어서, 4,096 x 2,540), #34#4.5K#34# 수평 해상도 또는 그 이상의 해상도로 비디오를 출력하도록 구성될 수 있다. 여기에서 사용된 것처럼, xk(상기에서 주목한 2K 및 4K와 같은)의 포맷으로 표현된 용어에서, 상기 #34#x#34# 양은 개략적인 수평 해상도를 나타낸다. 그것으로서, #34#4K#34# 해상도는 약 4000 또는 그 이상의 수평 픽셀에 대응하고, #34#2K#34#는 2000 또는 그 이상의 픽셀에 대응한다. 현재 상업적으로 가능한 하드웨어를 사용할 때, 상기 센서는 약 0.5인치(8mm)만큼 작을 수 있으나, 약 1.0인치 또는 그 이상일 수도 있다. 게다가, 상기 이미지 센서 18은 상기 센서 18의 오직 미리 결정된 부분을 선택적으로 출력하는 것에 의해서 다양한 해상도를 제공하도록 구성될 수 있다. 예를 들어서, 상기 센서 18 및/또는 상기 이미지 프로세싱 모듈(image processing module)은 사용자가 이미지 데이터 출력의 해상도를 확인하도록 구성될 수 있다.

카메라 10은 다운샘플(downsample)하고 2K, 1080p, 720p 또는 다른 해상도로 비디오 출력을 배출하기 위해 센서 18의 출력을 연속적으로 프로세스 하기 위하여 또한 구성될 수 있다. 예를 들어서, 상기 센서 18에서 이미지 데이터는 윈도우화(wi-

ossible that the gross weight of the housing 12 decreases. Moreover, in other embodiments, housing may include at least one storage device 24 in the inner portion. It can be mounted outside that. Moreover, it can be provided so that the housing 12 support the monitor module 26 and play back module 28. Moreover, in certain embodiments, the display 30 is configured to be outside the housing 12 the mount.

It can exist in the form of the lens system having at least one lens which is comprised in order to focus the image in which the optic hardware (optics hardware) 16 is flowed in on the image sensor 18. Selectively, it can exist in the form of the multilens system in which the optic hardware (optics hardware) 16 provides the various zooms, and the iris diaphragm (aperture) and focus. Moreover, the optic hardware (optics hardware) 16 is supported by the housing 12. It examples begins. It is not restricted. But the optic hardware (optics hardware) 16 can exist the lens system of the multiple other forms implying the accommodated socket the various sizes of lens systems including 50-100 mm (F2.8) zoom lens, 18-50 mm (F2.8) zoom lens, 300 mm (F2.8) zoom lens, 15 mm (F2.8) lens, 25 mm (F1.9) lens, 35 mm (F1.9) lens, 50 mm (F1.9) lens, 85 mm (F1.9) lens and/or the other lens in the form of the accommodated lens socket. In the above case, as it pays attention. Any lens the optic hardware (optics hardware) 16 is there adhered. In spite of that images are comprised in order to be focused on the light detecting surface of the image sensor 18.

CCD, CMOS, and the Foveon the example is not restricted the video sensor device of any form can become the image sensor 18 and the example is given. The image sensor 18 in any embodiments may include the CMOS device having the photo cell only about 1200. But the sensor of the other size can be used. In any configurations, the camera 10 is configured to output the video to the "2K#34 # (for example, 2048 x 1152 pixel), the "4K#34 # (4,096 x 2,540 the example is given), and the "4.5K" horizontal resolution or the resolution described in the above. Here, the "x" amount in the term, which as is used and expressed as the format of xk (like 2K and 4K which in the above case, it pays attention) exhibit the summary horizontal resolution. As that, the "4K" resolution corresponds to about 4000 or the horizontal pixel described in the above. The "2K" corresponds to 2000 or the pixel described in the above. Presently, the commercially possible hardware may be referred to about 1.0 inch, or more, the sensor can be small as about 0.5 inch (8mm) it uses. Moreover, by the result of that the image sensor 18 selectively outputs the only predetermined part of the sensor 18 various resolutions are configured to be provided. The example is given. The user the image processing module and/or the sensor 18 is configured to confirm the resolution of the image data output.

In order to consecutively process the output of the sensor 18 so that the camera 10 eject the video out to the downsample and 2K, 1080p, and 720p or the other resolution it can be comprised. The higher readout spe-

ndowed) 될 수 있고, 그것에 의해서 출력 이미지의 사이즈를 감소하고, 더 높은 리드 아웃 속도가 가능하게 한다. 그러나 다른 사이즈의 센서들 또한 사용될 수 있다. 게다가, 상기 카메라 10은 고 해상도에서 비디오 출력을 생산하기 위해 상기 센서 18의 출력을 업샘플(upsample)하기 위해 구성될 수 있다.

도 1 내지 3에 있어서, 어떠한 실시예들에서는, 상기 센서 18이 베이어 패턴 필터(Bayer pattern filter)를 포함할 수 있다. 그것으로서, 그 칩셋(도면 미도시)에 의해서, 상기 센서 18은 상기 이미지 센서(image sensor) 18의 개별적인 포토셀들에 의해 검출된 레드, 그린 또는 블루 라이트의 크기를 나타내는 데이터를 출력한다. 도 3은 상기 센서 18의 베이어 패턴 출력을 개략적으로 도시하였다. 어떤 실시예들에서는, 예를 들어서, 도 3에서 보여지는 것과 같이, 상기 베이어 패턴 필터는 레드 엘리먼트들(elements)의 수와 블록 엘리먼트들(element s)의 개수보다 두 배 많은 수의 그린 엘리먼트들(elements)을 가진다. 상기 이미지 센서 18의 칩셋은 상기 이미지 센서의 각 엘리먼트상에 차지(charge)를 읽기 위해 사용될 수 있고, 따라서, 잘 알려진 RGB 포맷 출력에서 값의 스트림을 출력한다.

도 4에 계속하여, 이미지 프로세싱 모듈(image processing module) 20은 어떠한 잘 알려진 수단에서 상기 이미지 센서(image sensor) 18에서의 데이터 스트림을 포맷하기 위해 선택적으로 구성될 수 있다. 어떠한 실시예들에서, 상기 이미지 프로세싱 모듈 (image processing module) 20은 그린, 레드 및 블루 이미지 데이터를 세 개 또는 네 개의 분리 데이터 컴파일(separate data compilations)로 분해하기 위해 구성될 수 있다. 예를 들어서, 상기 이미지 프로세싱 모듈(image processing module) 20은 레드 데이터를 하나의 레드 데이터 엘리먼트로 분리, 블루 데이터를 하나의 블루 데이터 엘리먼트로 분리, 및 그린 데이터를 하나의 그린 데이터 엘리먼트로 분리하기 위해서 구성될 수 있다. 예를 들어서, 도 4에 있어서, 상기 이미지 프로세싱 모듈(image processing module) 20은 레드 데이터 프로세싱 모듈 32, 블루 데이터 이미지 프로세싱 모듈 34, 및 제 1 그린 이미지 데이터 프로세싱 모듈 36을 포함할 수 있다.

그러나 상기에서 주목한 바와 같이, 도 3에 도시된 베이어 패턴 데이터는 다른 두 컬러보다 두 배의 많은 그린 픽셀을 가진다. 도 5는 블루와 레드 데이터가 제거된 데이터 컴포넌트(component)를 도시한 것으로, 단지 오리지널 그린 이미지 데이터만이 남아있다.

어떤 실시예들에서, 상기 카메라 10은 몇몇의 그린 이미지 데이터를 삭제하거나 누락하기 위해 구성될 수 있다. 예를 들어서, 어떠한 실시예들에서는, 상기 이미지 프로세싱 모듈(image processing module) 20은 총 그린 이미지 데이터량이 블루 및 레드 이미지 데이터의 총 양과 같도록 하기 위해서 그린 이미지 데이터의 1/2를 삭제하도록 구성될 수 있다. 예를 들어서, 도 6은 상기 이미지 프로세싱 모듈(image processing module) 20이 그린 이미지 데이터의 1/2를 삭제한 후 잔여 데이터를 도시한 것이다. 도 6의 도시된 실시예에서는, $n-3$, $n-1$, $n+1$ 및 $n+3$ 열이 삭제되었다. 이것은 삭제될 수 있는 그린 이미지 데이터의 패턴의 하나의 전형적인 예시이다. 다른 패턴과 다른 많은 그린 이미지 데이터가 삭제될 수 있다.

ed the size of the output image is reduced with that the example is given and image data can be in the sensor 18 the windowing (windowed) are made possible. But the sensors of the other size can be moreover used. Moreover, in the camera 10 is the high resolution, in order to produce the video out it is for the output of the sensor 18 with the upsample (upsample) below and it can be comprised.

As to the figures 1 through 3, the sensor 18 may include the bayer pattern filter in any embodiments. As that, data showing the red in which the sensor 18 is detected with the individual photo cells of the image sensor or 18, and the size of green or the blue light are outputted with the chip set (the drawing not illustrated). Fig. 3 schematically showed the bayer pattern output of the sensor 18. The bayer pattern filter the example is seen in fig. 3 the example is given in certain embodiments has the element (elements) which is more than the number of red elements and number of block elements with the twice drawn of the number. It is for the charge on each element of the image sensor with reading and the chip set of the image sensor 18 can be used. Therefore the stream of the value is outputted in the well known RGB format output.

In order to format data stream in the image sensor 18 in the well known means the image processing module 20 can be selectively comprised in fig. 4. In any embodiments, the image processing module 20 is configured to disassemble green, and red and blue image data to the force or four separation data compiles (separate data compilations). The example is given. In order to separate data in which the image processing module 20 draws the separation, and blue data red data with one red data element with one blue data element with the separation according to one data element drawn data can be comprised. The image processing module 20 as to fig. 4 the example is given comprises the red data processing module 32, and the blue data image processing module 34 and the image data processing module 36 drawn with the first.

But in the above case, the bayer pattern data illustrated in Figure 3 it pays attention has the pixel which is more than the other two colors with double drawn. Fig. 5 shows data component in which blue and red data are removed. And it remains only image data which it only draws original.

In any kind of operations, the camera 10 deletes image data drawn or it is configured to be missing. The example is given. The image processing module 20 is configured to delete 1/2 of image data which quantity of image data drawn draw in order to makes be the same as that of the total amount of red image data and blue from any embodiments. The example is given. And figure 6 shows remaining data 1/2 of the image data drawn by the image processing module 20 is deleted. In the illustrated embodiment of fig. 6, the $n-3$, the $n-1$, and the $n+1$ and $n+3$ heat were deleted. This may be one typical example of the pattern of deleted image data which it draws which. The other many image data which it draws which can be deleted with the other pattern.

다른 대안에서는, 상기 카메라 10이 레드 및 블루 이미지 데이터가 그린 이미지 데이터에 기초하여 변형된 후 그린 이미지 데이터의 1/2을 삭제하기 위해 구성될 수 있다. 이러한 선택적인 기술은 하기에 따라오는 다른 컬러 이미지 데이터에서 그린 이미지 데이터 값의 공제의 기술에서 묘사된다.

선택적으로, 상기 이미지 프로세싱 모듈(image processing module) 20은 그린 이미지 데이터를 선택적으로 삭제하기 위해서 구성될 수 있다. 예를 들어, 상기 이미지 프로세싱 모듈(image processing module) 20은 삭제하기 위한 어떠한 그린 이미지 데이터를 선택적으로 결정하기 위해 구성된 삭제 분석 모듈(deletion analysis module)(도면 미도시)을 포함할 수 있다. 예를 들어, 그러한 삭제 모듈(deletion module)은 그린 이미지 데이터에서 한 열의 패턴을 삭제하는 것이 모아레 라인(Moire line) 또는 다른 시각적으로 감지할 수 있는 인공앨리먼트들(artifacts)과 같은 인공앨리먼트들을 앨리어싱(aliasing)하는 결과를 만들어 낼지를 결정하기 위해서 구성될 수 있다. 삭제 모듈(deletion module)은 그러한 인공요소들을 생성하는 작은 위험을 제공하는 그린 이미지 데이터를 삭제하기 위해 선택되도록 더 구성될 수 있다. 예를 들어, 상기 삭제 모듈(deletion module)은 그것이 상기 이미지 센서(image sensor) 18에 의해 캡처된 이미지가 복수의 평행 수평선들에 의해서 특성화된 이미지 특징(feature)을 포함하는 것을 결정한다면, 교체된 수직 행들의 그린 이미지 데이터 삭제 패턴을 선택하기 위해 구성될 수 있다. 이 삭제 패턴은 이미지에서 검출된 수평 라인들에 평행한 이미지 데이터의 변경된 라인들의 삭제 패턴에서 야기된 모아레 라인(Moire Line)과 같은 인공앨리먼트들(artifacts)을 감소하거나 제거할 수 있다.

그러나 이것은 삭제 모듈(deletion module)에 의해 사용될 수 있는 삭제 패턴들 이미지 특성들(features)의 하나의 제한되지 않은 예에 불과하다. 삭제 모듈(deletion module)은 예를 들어, 이에 한정되지는 않으나, 교차열(alternating rows)의 삭제, 교차 대각선(alternating diagonal lines) 또는 다른 패턴과 같은 다른 이미지 데이터 삭제 패턴을 사용하고 다른 이미지 특성을 검출하기 위해서 구성될 수 있다. 게다가, 삭제 모듈은, 레드 및 블루 데이터 또는 사용된 센서의 형태에 의존하는 다른 이미지 데이터와 같은 그 다른 이미지 데이터의 부분을 삭제하기 위해 구성될 수 있다.

부가적으로, 카메라 10은 데이터 필드를 데이터 필드가 삭제된 것을 지시하는 이미지 데이터로 삽입되도록 구성될 수 있다. 예를 들어, 한정되지는 않으나, 카메라 10은 데이터 필드를 스토리지 디바이스(storage device) 24로 저장된 어떠한 비디오 클립의 시작에 삽입하기 위해 구성될 수 있고, 이는 비디오 클립의 각 #34#프레임들#34#에서 삭제된 것을 나타낸다. 어떠한 실시예들에서, 카메라는 데이터 필드를 센서 18에 의해 캡처된 각 프레임에 삽입하기 위해 구성될 수 있고, 이는 이미지 데이터가 삭제된 것을 나타낸다. 예를 들어, 어떤 실시예들에서는, 이미지 프로세싱 모듈(image processing module) 20이 하나의 삭제 패턴에서 그린 이미지 데이터의 1/2를 삭제하기 위해 구성되는 곳에서, 데이터 필드는 단일(single) 비트 데이터 필드만큼 작을 수 있으며, 이는 이미지 데이터가 삭제되었는지를 나타낸다. 이미지 프로세싱 모듈(image processing

In the other alternative, 1/2 of image data which it draws after being changed based on image data drawn by the camera 10 is red and blue image data is configured to be deleted. It is depicted in the technology of the subtraction of the image data value drawn in other color image data in which hereinafter the selective technology follows.

Selectively, in order to selectively delete image data which the image processing module 20 draws it can be comprised. The image processing module 20 the example is given may include the deletion analysis module (deletion analysis module) (Figure not illustrated) which selectively is configured to determine image data drawn for or deleting. The example is given. In order to pave the result of doing artificial elements such as the moire line and the dissimilar artificial element (artifacts) which it visually can sense which with the aliasing (aliasing) to delete the pattern of alternate chill and fever from image data which such erase module (deletion module) draws determine it can be comprised. In order to delete image data which provide the small danger in which the erase module (deletion module) creates that artifact factors drawn it is further configured to be selected. The example is given. The erase module (deletion module) determines that the image in which that is captured with the image sensor 18 includes the image feature peculiarized with multiple parallel horizontal lines. If it is the case it is to select the image data purging pattern drawing of the replaced vertical rows and the image can be comprised. The artificial element (artifacts) like the caused moire line is reduced in horizontal lines in which this deletion pattern is detected from the image by the changed deletion pattern of the lines of parallel image data or it can remove.

But this is nothing but one example which is not limited of the deletion pattern image feature (features) which can be used with the erase module (deletion module). The erase module (deletion module) gives the example. The example is not restricted. But in order to use the deletion of the cross row (alternating rows), and the other image data purging pattern such as the intersection diagonal (alternating diagonal lines) and the other pattern and detect the other image feature it can be comprised. Moreover, the erase module is configured to delete the part of other image data like other image data depending on the form of red and blue data or the used sensor.

Additionally, the camera 10 in this is each " frame " of the video clip the camera 10 is configured to insert data field into the beginning of any video clip stored as the storage device 24 it is configured to be inserted to image data which indicate that data field is data field deleted the example is given and the example is not restricted exhibit the deleted thing. And the camera in any embodiments exhibits the thing which is configured to insert data field into each frame captured with the sensor 18 and in which as to the this, image data are deleted. The example is given. The data field can be small in the place where the image processing module 20 is configured to delete 1/2 of image data drawn from certain embodiments from one deletion pattern as the single bit data field. And it shows whether as to the this, image

module) 20은 단지 하나의 패턴에서 데이터를 삭제하도록 구성되었기 때문에, 단일 비트는 데이터가 삭제되었는지를 나타내기에 충분하다.

어떠한 실시예들에서는, 상기에서 주목한 바와 같이, 이미지 프로세싱 모듈(image processing module) 20이 하나의 패턴보다 더 많은 패턴에서 이미지 데이터를 선택적으로 삭제하기 위해 구성될 수 있다. 따라서, 이미지 데이터 삭제 필드는 더 커질 수 있으며, 이는 복수의 다른 이미지 데이터 삭제 패턴이 사용됨의 지시를 제공하기 위한 충분한 수의 값을 포함한다.

이 데이터 필드는 다운스트림 컴포넌트들 및/또는 잔여 이미지 데이터가 응답하는 공간 위치를 결정하기 위한 프로세스에 의해 사용될 수 있다.

어떠한 실시예들에서, 이미지 프로세싱 모듈(image processing module)은 예를 들어서, 도 5에서 도시된 데이터와 같은, 모든 로(raw) 그린 이미지 데이터의 보유하기 위해 구성될 수 있다.

상기에서 주목한 바와 같이, 알려진 베이어 패턴 필터에서, 레드 엘리먼트들과 블루 엘리먼트들의 수보다 두 배 많은 그린 엘리먼트들이 존재한다. 즉, 레드 엘리먼트들은 총 베이어 패턴 필터의 25%를 구성하고, 블루 엘리먼트들은 베이어 패턴 어레이의 25%에 상응되며, 그린 엘리먼트들은 베이어 패턴 어레이의 엘리먼트들의 50%를 구성한다. 이와 같이, 어떠한 실시예들에서는, 모든 그린 이미지 데이터가 보유되는 곳에서, 이미지 프로세싱 모듈(image processing module) 20이 제 2 그린 데이터 이미지 프로세싱 모듈 38을 포함할 수 있다. 그것처럼, 제 1 그린 데이터 이미지 프로세싱 모듈 36은 그린 엘리먼트들의 절반을 처리할 수 있고, 제 2 그린 데이터 이미지 프로세싱 모듈 38은 잔여 그린 엘리먼트들을 처리할 수 있다. 그러나 본 발명은 예를 들어서, 제한은 없지만, CMY 및 RGB와 같은 다른 형태의 패턴과 함께 사용될 수 있다.

도 7은 모듈 32, 34, 36 및 38(도 4)에 의해 프로세스된 레드, 블루 및 두 개의 그린 데이터를 개략적으로 도시한 것을 포함한다. 이것은 그들이 거의 동일한 양의 데이터를 핸들링하므로, 이러한 모듈들의 각 크기 및 구성이 거의 같을 수 있기 때문에, 보다 유리함을 제공할 수 있다. 게다가, 이미지 프로세싱 모듈(image processing module) 20은 모든 그린 이미지 데이터(모듈 36 및 38 모두 사용에 의해)를 처리하는 모드 및 그린 데이터의 1/2가 삭제(그것은 모듈 36 및 38의 단지 하나만을 이용)하는 모드 사이에서 선택적으로 스위치 될 수 있다. 그러나 다른 구성 또한 사용 가능하다.

부가적으로, 어떤 실시예들에서는, 이미지 프로세싱 모듈(image processing module) 20이 다른 모듈을 포함할 수 있고/있거나 예를 들어서, 제한되지는 않으나, 감마 수정 프로세스, 노이즈 필터링 프로세스 등과 같은 다른 프로세스를 수행하기 위해 구성될 수 있다.

게다가, 어떠한 실시예들에서는, 이미지 프로세싱 모듈(image

data were deleted. The image processing module 20 only was configured to delete data from one pattern. Therefore it is sufficient to show whether as to the single bit, data were deleted.

In any embodiments, in the above case, as shown in it pays attention the image processing module 20 selectively is configured to delete image data from more pattern than one pattern. Therefore, the image data purging field comprises this is the multiple other image data purging patterns it can be more enlarged which is the value of enough number for providing the indication it is used.

It can be used by the process where this data field determines the spatial position in which downstream components and/or residual image data answer.

In any embodiments, the image process module (image processing module) gives the example. It is configured to hold of image data drawn with all furnace (raw) like the data, illustrated in fig. 5.

In the above case, elements which are more than the number of red elements and blue elements in the bayer pattern filter, which as shown in pays attention is known with the twice drawn exist. That is, red elements organize 25% of the total bayer pattern filter. Blue elements correspond to 25% of the bayer pattern array. And elements drawn organize 50% of the elements of the bayer pattern array. In this way, in any embodiments, data image processing module 38 which the image processing module 20 draws is include might in the place where image data drawn are held. The half of the elements which data image processing module 36 drawn like that with the first draws can be processed. Elements which the image data processing module 38 drawn with the second draws with residual can be processed. But the invention gives the example. There is no limit. However the example can be used with the pattern of the other form such as CMY and RGBW.

Fig. 7 comprises 32 module, 34, 36, the red processed with 38 (Figure 4), and blue, and the thing showing two data drawings. They as to the this, handle data of the equal balance in the nearly. Therefore the measure of angle and configuration of this modules can be nearly the same. Therefore they can provide to be more advantageous. Moreover, the selectively can be switched to the image processing module 20 between the mode which 1/2 of the mode processing image data (using both 36 module and 38 use) drawn and data drawing does with deletion (that is 36 module and 38, area, the usage only one). But it is moreover usable the other configuration.

Additionally, the module having a different image processing module 20 in the certain embodiment is included might and it has or the example is given. It is not limited. But the other process including the gamma correction process, the noise filtering process etc. is configured to be performed.

Moreover, in any embodiments, the image processing

processing module) 20은 블루 엘리먼트 및/또는 레드 엘리먼트의 값에서 그린 엘리먼트의 값을 공제하기 위해 구성될 수 있다. 그것처럼, 어떠한 실시예들에서, 어떠한 컬러는 이미지 센서 18에 의해 검출될 때, 대응하는 레드 또는 블루 엘리먼트는 0으로 감소할 수 있다. 예를 들어서, 많은 사진들에서, 많은 영역의 블랙, 화이트 또는 그레이 또는 레드 또는 블루 컬러로 편향된 그레이에서 변경된 어떠한 색이 존재할 수 있다. 이와 같이, 만약 이미지 센서 18의 대응 픽셀이 그레이 영역을 검출한다면, 그린, 레드 및 블루의 크기는 거의 동일할 것이다. 이와 같이, 만약 그린 값이 레드 및 블루 값들에서 공제된다면, 레드 및 블루 값들은 0 또는 0 근처로 떨어질 것이다. 이와 같이, 연속적인 압축 프로세싱에서, 블랙, 화이트 또는 그레이 영역을 검출한 픽셀에서 생성된 많은 0들이 존재할 것이고, 이 결과 데이터는 더욱 압축화될 것이다. 게다가, 하나 또는 두 대의 다른 컬러에서 그린의 공제는 결과 이미지 데이터가 다른 이유들에 의해 더욱 압축화 되도록 만들 것이다.

그러한 기술은 더 높은 효율의 압축비를 달성하고, 오리지널 이미지 데이터의 엔트로피(entropy)로의 그것의 관계 때문에 외형적으로는 손실이 없게 여전히 남을 수 있도록 도울 수 있다. 예를 들어서, 이미지의 엔트로피가 이미지상에서 많은 양의 무작위와 관련된다. 예를 들어서, 다른 컬러의 이미지 데이터에서 하나의 컬러 이미지 데이터의 공제는 무작위성(randomness)을 감소할 수 있고, 따라서 그러한 컬러의 이미지 데이터의 엔트로피를 감소하며, 그것에 의해서 데이터가 적은 손실을 가지고 높은 압축비에서 압축되도록 한다. 일반적으로, 이미지는 랜덤 컬러 값의 컬렉션이 아니다. 오히려, 주위(surrounding) 픽처 엘리먼트들 사이에 어떠한 정도의 상호연관성(correlation)이 종종 존재한다. 따라서, 공제기술(subtraction technique)은 더 나은 압축을 달성하기 위하여 픽처 엘리먼트의 상호연관성을 이용할 수 있다. 많은 양의 압축은, 적어도 일부분에서, 이미지상에서 오리지널 정보의 엔트로피에 의존할 것이다.

어떠한 실시예들에서 레드 또는 블루 픽셀에서 공제된 크기는 주요 레드(subject red) 또는 블루 픽셀에 인접한 그린 픽셀에서 출력된 값의 크기가 될 수 있다. 게다가, 어떤 실시예에서는, 레드 또는 블루 픽셀에서 추출된 그린 크기는 주위 그린 엘리먼트의 평균에서 유도될 수 있다. 그러한 기술은 아래에서 더욱더 자세히 묘사될 것이다. 그러나 다른 기술도 또한 사용가능하다.

선택적으로, 이미지 프로세싱 모듈(image processing module) 20은 다른 컬러에서 그린 이미지 데이터를 선택적으로 공제하기 위해서 구성될 수 있다. 예를 들어서, 이미지 프로세싱 모듈(image processing module) 20은 다른 컬러 중 하나의 이미지 데이터의 부분에서 그린 이미지 데이터를 공제하는 것이 더 나은 압축력을 제공할지 여부를 결정하기 위해 구성될 수 있다. 이러한 모드에서, 이미지 프로세싱 모듈(image processing module) 20은 플래그(flags)를 어떤 이미지 데이터의 부분이 변경되었는지(예를 들어, 그린 이미지 데이터 공제)와 어떤 부분이 꽤 변경되지 않았는지를 나타내는 이미지 데이

module 20 is configured to deduct the value of the element drawn from the value of the blue element and/or the red element. In any embodiments like the that, when any color is detected by the image sensor 18 the corresponding red or the blue element can reduce to 0. The example is given. Any colour changed in the gray deflected to the black of many area, and white or gray or red or the blue color can exist in many photographs. In this way, the opposition pixel of the image sensor 18 detects the grey area. If it is the case green, and the size of blue and red will be nearly identical. In this way, the green value is deducted from red and blue values. If it is the case red and blue values will be fallen 0 or 0 vicinity. In this way, in the successive compression processing, many 0 which are generated in the pixel detecting black, and white or the grey area will exist. Data will be as a result of this more pressed. Moreover, it will produce in order to be more pressed with the reasons having a different subtraction of green is result image data in the other color of one or two parts.

That technology achieves the compression ratio of the much higher efficiency. It therefore has with its relation to the entropy (entropy) of original image data. It helps so that there is no loss it remain. The example is given. The entropy of the image relates to many randomizing of the amount on the image. The example is given. The subtraction of one color image data can reduce the randomness by image data of the other color. Therefore the entropy of image data of that color is reduced. And it is compacted in the high compression ratio having the loss in which data are less with that. Generally, it is not image the collection of the random color. Rather, the interconnectivity (correlation) of about any often exists between surrounding picture elements. Therefore, the subtractor liquor (subtraction technique) may be formed of the interconnectivity of the picture element the compression is achieved. In at least one part, many compression of the amount will depend on the entropy of the original information on the image.

In any embodiments, it can be sized in the pixel in which the size deducted from red or the blue pixel is adjacent to the major red (subject red) or the blue pixel drawn of the output value. Moreover, in the certain embodiment, the size which is extracted from red or the blue pixel drawn can be induced in the average of the element drawn. In that technology is the lower part, it will be more and more depicted in detail. But the other technology is moreover usable.

Selectively, so that the image processing module 20 selectively deduct image data drawn from the other color or it can be comprised. The example is given. The image processing module 20 is configured to determine if the compressive force is provided among the other color to deduct image data drawn from the part of one image data. In this mode, it is configured to insert within image data in which the image processing module 20 shows whether (the image data subtraction drawn for example) and any kind of part were not changed whether

터 내에 삽입하기 위해 구성될 수 있다. 그러한 플래그를 가지고, 다운스트림 디모자이크/재구성(reconstruction) 컴포넌트는 그린 이미지 값을 다른 컬러의 이미지 데이터에 되돌려 선택적으로 부가할 수 있고, 이는 그러한 데이터 플래그의 상태에 기초한다.

선택적으로, 이미지 프로세싱 모듈(image processing module) 20은 레드 및 블루 데이터의 값을 라운드(round)하기 위해 구성된 다른 데이터 감소 모듈(도면 미도시)을 또한 포함할 수 있다. 예를 들어, 그린 크기의 추출 후에, 레드 또는 블루데이터는 거의 0이다(예를 들어, 고해상도 시스템을 위해 0-255 또는 그 이상의 크기의 범위를 가지는 8-비트 스케일 범위 상에서 1 또는 2 이내). 예를 들어, 센서 18은 0-4095 스케일 상에 레드, 블루 및 그린 데이터를 출력하는 12-비트 센서가 될 수 있다. 데이터의 어떠한 라운딩(rounding) 또는 필터링(filtering)은 라운딩 모듈이 바람직한 효과를 달성하도록 조정될 수 있는 것을 수행한다. 예를 들어, 라운딩은 손실 없는 출력을 가지는 것이 바람직하다면 덜 수행될 수 있고, 어떠한 손실이나 손실 출력이 허용된다면 대부분 수행될 것이다. 어떤 라운딩은 수행될 수 있고, 여전히 외형적으로 손실 없는 출력 결과를 가진다. 예를 들어, 8-비트 스케일 상에서, 2 또는 3까지의 절대값을 가지는 레드 또는 블루 데이터는 0으로 라운딩 되고, 여전히 외형적으로 무손실 출력을 제공한다. 게다가, 12-비트 스케일에서, 10에서 20까지의 절대값을 가지는 레드 또는 블루 데이터는 0으로 라운드 될 수 있고, 여전히 외형적으로 손실 없는 출력을 제공한다.

게다가, 0으로 라운드 될 수 있거나 다른 값으로 라운드 될 수 있는 값의 크기는 여전히 시스템의 구성에 의존하여 외형적으로 손실 없는 출력을 여전히 제공하는데, 이러한 시스템은 옵틱 하드웨어 16, 이미지 센서 18, 이미지 센서의 해상도, 이미지 센서 18의 컬러 해상도(비트), 필터링 형태, 앤티-앨리어싱 기술 또는 이미지 프로세싱 모듈 20에 의해 수행되는 다른 기술, 압축 모듈 22에 의해 수행되는 압축기술 및/또는 카메라 10의 다른 파라미터 또는 특성을 포함한다.

상기에서 주목한 것처럼, 어떠한 실시예들에서, 카메라 10은 레드 및 블루 이미지 데이터가 그린 이미지 데이터에 기초하여 변형된 이후 그린 이미지 데이터의 1/2을 삭제하기 위해서 구성될 수 있다. 예를 들어, 한정하는 것은 아니나, 프로세서 모듈 20은 주위 그린 데이터 값의 크기의 평균이 레드 및 블루 데이터 값에서 공제된 이후 그린 이미지 데이터의 1/2를 삭제하기 위해 구성될 수 있다. 그린 데이터에서 이러한 공제는 연관된 하드웨어 상에서 처리량 요구를 감소할 수 있다. 게다가, 잔여 그린 이미지 데이터는 레드와 블루 이미지 데이터를 재구성하기 위해 사용될 수 있고, 이는 도 14 내지 16과 관련한 하기에서 보다 설명된다.

상기에서 주목한 것처럼, 카메라 10은 압축 모듈(compression module) 22를 또한 포함할 수 있다. 압축 모듈(compression module) 22는 분리 칩의 형태로 존재할 수

he part of any kind of image data was the flag (flags) changed or not or not. The image value which the downstream demosaic / reconfiguration (reconstruction) component draws is returned with that flag in image data of the other color and it selectively can add. This is based than on the state of that data flag.

Selectively, the other data reduction module (Figure not illustrated) in which the image processing module 20 is for the value of blue data and red with the round (round) below and which is comprised is include might moreover. The example may be referred to red after the extraction of the size which it draws it gives or the blue data, nearly, 0 (1 on 8-bit scale range having range of 0-255 or the size described in the above or 2 within for high-resolution system the example is given). The sensor 18 the example is given becomes 12-bit sensor outputting red, and blue and data drawing on 0-4095 scale. Any rounding (rounding) or the filtering of data performs to is adapted to achieve the effect that the rounding module does with desirable. The example is given. The there is no with loss generating power can be less performed that the rounding has the generating power which. The generating power will be performed if any loss or the damage output power is allowed. Any kind of rounding has the output result being performed and of there being still externally no with loss. The red having the absolute value of 2 on 8-bit scale, or 3 the example is given or blue data is rounded to 0. The lossless output is still externally provided. Moreover, the red having the absolute value of 20 in 12-bit scale, in 10 or blue data can be rounded to 0. The output which there is still externally no with loss is provided.

Moreover, the size of the value which can be rounded to 0 or can be rounded by the other value comprises this system is the optic hardware 16, the image sensor 18, the resolution of the image sensor, the color definition (bit) of the image sensor 18, the filtering form, the anti-aliasing technology or the other technology performed by the image processing module 20, and the other parameter of the camera 10 and/or the compression technology performed by the compressive module 22 or property the output which there is externally no with loss is still provided it still depends on the system configuration.

In the above case, in order to delete 1/2 of image data which it draws since being changed based on image data drawn by the camera 10 is red and blue image data in any embodiments it pays attention it can be comprised. The example is given. It does not limit. But the processor module 20 is configured to delete 1/2 of image data which the average of the size of data value drawn draws since being deducted from red and blue data value. The treatment quantity demand can be reduced by data drawing on the hardware in which such subtraction is related. Moreover, so that image data drawn with residual reconstruct red and blue image data it can be used. Blue image data are below explained. This relates with the figures 14 through 16.

In the above case, as it pays attention. The camera 10 moreover may include the compressive module (compression module) 22. The compressive module (compression

있고, 그것은 소프트웨어나 다른 프로세서를 가지고 구현될 수 있다. 예를 들어서, 압축 모듈(compression module) 22는 JPEG2000 표준 또는 다른 압축 기술에 따른 압축 기술을 수행하는 상업적으로 이용가능한 압축 칩의 형태로 존재할 수 있다.

압축모듈은 이미지 프로세싱 모듈(image processing module) 20에서 데이터 상의 어떠한 형태의 압축 프로세스를 수행하기 위해 구성될 수 있다. 어떠한 실시예들에서, 압축 모듈(compression module) 22는 이미지 프로세싱 모듈(image processing module) 20에 의해 수행되는 기술의 이점을 이용하는 압축 기술을 수행한다. 예를 들어서, 상기에서 주목한 것처럼, 이미지 프로세싱 모듈(image processing module) 20은 그린 이미지 데이터의 크기를 공제함으로써 레드 및 블루 데이터의 값의 크기를 감소하기 위해 구성될 수 있고, 이로 인하여, 더 큰 0의 값뿐만 아니라 다른 효과까지도 야기한다. 게다가, 이미지 프로세싱 모듈(image processing module) 20은 이미지 데이터의 엔트로피를 이용하는 로(raw) 데이터의 조작을 수행할 수 있다. 이와 같이, 압축 모듈 22에 의해 수행되는 압축 기술은 거기에서 출력된 압축된 데이터의 사이즈를 감소하기 위해 더 큰 0의 큰 스트링의 존재에서 이득을 얻는 형태일 수 있다.

게다가, 압축모듈(compression module) 22는 외형적으로 손실 없는 출력을 야기하기 위해 이미지 프로세싱 모듈(image processing module) 20에서 이미지 데이터를 압축하기 위해 구성될 수 있다. 예를 들어서, 처음으로, 압축모듈(compression module)은, 제한은 없으나, JPEG2000, 모션JPEG, 모든 DCT 기본 코덱, 압축된 GRB 이미지 데이터를 위해 디자인된 모든 코덱, H.264, MPEG4, 호프만, 또는 다른 기술과 같은 모든 알려진 압축 기술을 적용하기 위해 구성될 수 있다.

사용된 압축 기술의 형태에 의존하여, 압축기술의 다양한 파라미터가 외형적으로 손실 없는 출력을 제공하기 위해 배치될 수 있다. 예를 들어서, 상기에서 주목한 많은 압축 기술은 다른 압축비로 조정될 수 있고, 여기에서 압축해제될 때, 결과 이미지는 낮은 압축비를 위해 향상된 질이고, 높은 압축비를 위해서는 낮은 질이다. 이와 같이, 압축모듈은 외형적으로 손실 없는 출력을 제공하는 방법에서 이미지 데이터를 압축하기 위해서 구성될 수 있거나, 사용자가 외형적으로 손실 없는 출력을 얻기 위한 다양한 파라미터를 조정하도록 구성될 수 있다. 예를 들어서, 압축 모듈 22는 약 6:1, 7:1, 8:1 또는 그 이상의 압축비에서 이미지 데이터를 압축하도록 구성될 수 있다. 어떠한 실시예들에서, 압축 모듈 22가 12:1 또는 그 이상의 비로 이미지 데이터를 압축하기 위해 구성될 수 있다.

sion module) 22 can exist in the form of the separating chip. That can be implemented with software or the other processor. The example is given. The example can exist in the form of the commercially available compression chip in which the compressive module (compression module) 22 performs the compression technology according to JPEG2000 standard or the other compression technology.

In the compressive module is the image processing module 20, the compression process of any form on data is configured to be performed. The compression technology using the advantage of the technology in which the compressive module (compression module) 22 is performed in any embodiments with the image processing module 20 is performed. The example is given. In the above case, as it pays attention. The size of the value of red and blue data are configured to be reduced by subtracting the size of image data which the image processing module 20 draws. It causes to not only the value of 0 which is due to this greater but also the other effect. Moreover, the operation of furnace (raw) data using the image processing module 20 is the entropy of image data can be performed. In this way, the size of the compacted data outputted from the compression technology performed by the compressive module 22 is the there may be referred to the form which obtains the gain from the presence of the large string of greater 0 in order to reduce.

Moreover, so that the compressive module (compression module) 22 cause the output which there is externally no with loss image data are configured to be compressed from the image processing module 20. The example is given. The compressive module (compression module) is compacted for the first time and there is no limit. But known compression technologies such as all codecs, H.264, MPEG4, huffman designed for JPEG2000, motion JPEG, all DCT basic codecs, and compacted GRB image data and the other technology are configured to be applied.

It depends on the form of the used compression technology. So that the various parameter of the compression technology provide the output which there is externally no with loss the form can be arranged. The example may be referred to the it is for the high compression ratio and low. Quality which it gives and many compression technology which in the above case, it pays attention can be adjusted to the other compression ratio and when it is compression-released by the here is the improved quality for the compression ratio in which the resultant image is low In this way, in the method of providing the output in which there is externally no compressive module with loss, it can be comprised in order to compress image data or the user is configured to control the various parameter for obtaining the generating power which there is externally no with loss. The example is given. The compressive module 22 is configured to compress image data from about 6:1, 7:1, and 8:1 or the compression ratio described in the above. In any embodiments, the compressive module 22 is configured to compress image data to 12:1 or the ratio described in the above.

게다가, 압축 모듈(compression module) 22는 사용자가 압축 모듈(compression module) 22에 의해 달성된 압축비를 조정할 수 있도록 구성될 수 있다. 예를 들어서, 카메라 10은 사용자가 압축모듈(compression module) 22가 압축비가 변하도록 하는 명령을 입력할 수 있도록 하는 유저 인터페이스를 포함할 수 있다. 이와 같이, 어떤 실시예들에서는 카메라 10이 다양한 압축을 제공할 수 있다.

여기에서 사용된 것처럼, #34#외형적으로 손실 없는#34#이라는 용어는, 동일한 디스플레이 디바이스상에서 오리지널 이미지 데이터(압축되지 않은)를 가지고 나란히 비교될 때, 당업자 중의 하나가 이미지의 단순한 시각적인 검사에 기초하여, 어떤 이미지가 논리적인 정확도를 가지는 오리지널인지 결정할 수 없는 출력을 포함하도록 의도된다.

도 1에 계속하여, 카메라 10은 스토리지 디바이스(storage device) 24를 또한 포함한다. 스토리지 디바이스(storage device)는 예를 들어서, 한정되지는 않으나, 하드디스크, 플래시 메모리 또는 다른 형태의 메모리 디바이스와 같은 어떤 형태의 디지털 스토리지의 형태가 될 수 있다. 어떠한 실시예들에서, 스토리지 디바이스(storage device) 24의 크기는 12 메가 픽셀 해상도, 12-비트 컬러 해상도 및 초당 60프레임에서 적어도 약 비디오의 30분에 대응하는 압축모듈 22에서 이미지 데이터를 저장하기 위해 충분히 클 수 있다. 그러나 스토리지 디바이스(storage device) 24는 어떠한 크기를 가질 수 있다.

어떤 실시예들에서, 스토리지 디바이스(storage device) 24가 하우징(housing) 12의 외측상에 마운트 될 수 있다. 게다가, 어떤 실시예들에서는, 스토리지 디바이스(storage device) 24가 예를 들어서, 한정되지는 않으나, IEEE1394, USB 2.0, IDE, SATA 등을 포함하는 표준 통신 포트를 통하여 시스템 14의 다른 컴포넌트들에 연결될 수 있다. 더욱이, 어떤 실시예들에서는, 스토리지 디바이스(storage device) 24는 RAID 프로토콜 상에서 운영되는 복수의 하드 드라이브를 포함할 수 있다. 그러나 어떠한 형태의 스토리지 디바이스가 사용될 수도 있다.

도 1에 계속하여, 상기에서 주목한 바와 같이, 어떠한 실시예들에서, 시스템은 사용자가 동작 동안 이미지 센서(image sensor) 18에 의해 캡처된 비디오 이미지를 볼 수 있도록 구성된 모니터 모듈(module) 26과 디스플레이 디바이스(display device) 30을 포함할 수 있다. 어떠한 실시예들에서는, 이미지 프로세싱 모듈(image processing module) 20은 감소된 해상도 이미지 데이터를 모니터 모듈(module) 26에 출력하기 위해 구성된 서브샘플링 시스템을 포함할 수 있다. 예를 들어서, 그러한 서브샘플링 시스템은 2K, 1080p, 720p 또는 다른 해상도를 지원하기 위한 미디어 이미지 데이터를 출력하기 위해 구성될 수 있다. 어떠한 실시예들에서, 디모자이크를 위해 사용된 필터는 다운샘플링 및 필터링을 또한 수행하기 위해 채용될 수 있고, 그러한 다운샘플링 및 필터링은 동시에 수행될 수 있다. 모니터 모듈(module) 26은 이미지 프로세싱 모듈(image processing module) 20에서의 데이터에 어떠한 형태의 디모자이크 프로세싱을 수행하기 위해 구성될 수 있다. 그 후, 모니터 모듈(module) 26은 디모자이크된 이미지 데이터를 디스플레이(display) 30에 출력할 수 있다.

Moreover, the compressive module (compression module) 22 can be comprised so that the user control the compression ratio accomplished by the compressive module (compression module) 22. The camera 10 the example is given may include the user interface in which the compressive module (compression module) 22 of the user inputs the command in which the compression ratio changes. In this way, in certain embodiments, the camera 10 can provide various compressions.

Here, it is intended so that one of person skilled in the art it is side by side compared to the " outer shape on the identical with 34 display device which there is no with loss with the original image data (it is not compacted) it is used include the output which whether it is the original having the accuracy in which any kind of image is logical or not cannot determine based on the simple visual inspection of the image.

And then, the camera 10 moreover includes the storage device 24 in fig. 1. Examples the storage device gives. It is not restricted. But it can be formed of the hard disk, and the digital storage of any type like the memory device of the flash memory or the other form. In any embodiments, the size of the storage device 24 can be per second enough big with 12 mega pixel resolution, 12-bit color resolution of 60 frame in order to store image data in the compressive module 22 corresponding to 30 minutes of at least about video. But the storage device 24 has any size.

In certain embodiments, the storage device 24 can be mounted in the outer head of the housing 12. Moreover, in certain embodiments, the storage device 24 gives the example. The example is not restricted. But it can be connected to the other components of the system 14 through the standard communication port including the IEEE1394, USB 2.0, IDE, SATA etc. Furthermore, the storage device 24 in the certain embodiment may include the multiple hard drives which the RAID protocol phase manages. But it can be used with the storage heavy dressing lice Suga of any form.

The system in any embodiments and then, in the above case, it pays attention to fig. 1 comprise the monitor module 26 configured to the user look at the video image which is captured with the image sensor 18 for the operation and the display device 30. The image processing module 20 in any embodiments may include the sub-sampling system in which the reduced resolution is configured to output image data to the monitor module 26. The example is given. Media image data in which such sub-sampling system supports 2K, 1080p, 720p or the other resolution is configured to be outputted. In any embodiments, in order to moreover perform the downsampling and filtering the filter used for the demosaic can be employed. That downsampling and filtering can be performed. The monitor module 26 is configured to perform the demosaic processing of any form in data in the image processing module 20. Thereafter, image data in which the monitor module 26 is demosaiced can be outputted to the display 30.

디스플레이(display) 30은 어떠한 형태의 모니터링 디바이스 일 수 있다. 예를 들어서, 한정은 아니나, 디스플레이(display) 30은 하우징(housing) 12에 의해 지지되는 4-인치 LCD 패널 일 수 있다. 예를 들어서, 어떤 실시예들에서는, 디스플레이(display) 30은 사용자가 하우징(housing) 12와 관련한 어떠한 각도에서도 디스플레이(display) 30을 볼 수 있도록 하기 위해서, 디스플레이(display) 30이 하우징(housing) 12와 관련한 어떠한 위치로도 조절될 수 있도록 구성된 무한정 조정 가능한 마운트에 연결될 수 있다. 어떠한 실시예들에서, 디스플레이(display) 30은 예를 들어서, RGB 또는 YCC 포맷 비디오 케이블과 같은 어떠한 형태의 비디오 케이블을 통하여 모니터 모듈로 연결된다.

선택적으로, 플레이 백 모듈(play back module) 28은 스토리지 디바이스(storage device) 24에서 데이터를 수신하고, 이미지 데이터를 압축해제 및 디모자이크 하고 나서, 이미지 데이터를 디스플레이(display) 30에 출력하도록 구성될 수 있다. 어떤 실시예들에서는 모니터 모듈(monitor module) 26 및 플레이 백 모듈 (play back module) 28은 매개(intermediary) 디스플레이 컨트롤러(도면 미도시)를 통하여 디스플레이에 연결될 수 있다. 그것처럼, 디스플레이(display) 30은 디스플레이 컨트롤러에 단일커넥터를 가지고 연결될 수 있다. 디스플레이 백 모듈(play back module) 28에서 디스플레이(display) 30에 데이터를 전송하기 위해 구성될 수 있다.

도 8은 카메라에 10에 의한 이미지 데이터의 프로세싱을 도시한 플로어 차트 50을 포함한다. 어떤 실시예들에서, 플로어 차트 50은 스토리지 디바이스(storage device) 24 또는 카메라 10 내부에 또 다른 스토리지 디바이스(도면 미도시)와 같은 메모리 디바이스에 저장된 컨트롤 루틴을 나타낼 수 있다. 게다가, 중앙 처리 장치(CPU)(도면 미도시)는 컨트롤 루틴을 수행하기 위해 구성될 수 있다. 플로어 차트 50에 대응하는 방법의 하기 기술사항은 비디오 카메라 데이터의 단일 프레임의 처리 과정이 묘사된 것이다. 따라서, 그 기술은 단위 정지 이미지의 처리과정에 적용될 수 있다. 이러한 프로세스들은 12보다 큰 프레임 비율뿐만 아니라 20, 23.974, 24, 30, 60 및 120 또는 이러한 프레임 또는 더 큰 사이에 존재하는 다른 프레임 비율과 같은 연속적인 비디오의 처리과정에 또한 적용될 수 있다.

도 8에 계속하여, 컨트롤 루틴은 시행 블록(operation block) 52에서 시작될 수 있다. 시행 블록 52에서, 카메라 10은 센서 데이터를 획득한다. 예를 들어서, 도 1에서, 바이어 센서 및 칩셋을 포함할 수 있는 이미지 데이터 18은 이미지 데이터를 출력할 수 있다.

예를 들어, 한정되지는 않으나, 도 3에 있어서, 이미지 센서는 그 라이트 수신 표면에 바이어 패턴 필터를 가지는 CMOS 디바이스를 포함할 수 있다. 이와 같이, 옵틱 하드웨어 16에서 포커싱된 이미지는 이미지 센서(image sensor) 18의 CMOS 디바이스 상의 바이어 패턴 필터 상에 포커싱 된다. 도 3은 CMOS 디바이스상에 바이어 패턴 필터의 정렬에 의해서 생성된 바이어 패턴의 예를 나타낸 것이다.

도 3에서, 열 m은 바이어 패턴의 좌측 에지에서 4번째 열이고, 열 n은 패턴의 상단에서 4번째 열이다. 나머지 행 및 열은 행 m 및 열 n과 관련하여 라벨(label)된다. 그러나 이러한 레이아웃

The display 30 may be the monitoring device of any form. The example may be referred to 4- inch LCD panel in which it gives and it is not limitation and but the display 30 is supported by the housing 12. It can be connected to the unlimited configured to gives the example. In order that the user the display 30 looks at the display 30 in certain embodiments in any angle that relates with the housing 12 the display 30 be adjusted to any position that relates with the housing 12 adjustable the mount. In any embodiments, the display 30 gives the example. It is connected to the monitor module through the video cable of any form like RGB or the YCC format video cable.

Selectively, in the play back module 28 is the storage device 24, data are received. Image data is decompression and demosaic. And yet image data are configured to be outputted to the display 30. In certain embodiments, the monitor module (monitor module) 26 and play back module 28 can be connected to display through the intermediation (intermediary) display controller (the drawing not illustrated). The display 30 can be connected to the display controller like that with the single connector. In the display controller is the monitor module 26 or the play back module 28, data are configured to be transmitted in the display 30.

Fig. 8 comprises the flow chart 50 showing the processing of image data by 10 in the camera. The flow chart 50 in the certain embodiment exhibits the control routine stored in and, the memory device like the other storage device (the drawing not illustrated) inside the storage device 24 or the camera 10. Moreover, the central processing unit (CPU) (the drawing not illustrated) is configured to perform the control routine. The process step of the single frame of video camera data below item of technology of the method corresponding to the flow chart 50 is depicted. Therefore, the technology can be applied in the process step of the unit still image. This processes can be moreover applied in the process step of the successive video like not only the large frame rate but also 20, 23.974, 24, 30, 60 and 120 or such frame or the other frame rate of existing while being greater than 12.

And then, the control routine can be initiated in the trial block (operation block) 52 in fig. 8. In the trial block 52, the camera 10 obtains sensor data. The example is given. The image data 18 may include the Bayer sensor and chip set in fig. 1 can output image data.

For example, the image sensor as to fig. 3 it is not restricted may include the CMOS device having the bayer pattern filter on the light receiving surface. In this way, the image focused from the optic hardware 16 is focused on the bayer pattern filter on the CMOS device of the image sensor 18. Figure 3 shows the example of the bayer pattern which is according to due to the arrangement of the bayer pattern filter on the CMOS device and is generated.

The heat m in fig. 3 may be the heat n is 4 the heat in the upper end of the pattern it is cut. It becomes the first row and heat in connection with the row m and he

은 도시화(illustration) 목적을 위해 임의적으로 단지 선택된 것으로, 여기에서 개시된 실시예 및 발명의 어떠한 한정도 하지 않는다.

상기에서 주목한 것처럼, 알려진 베이어 패턴 필터는 블루 및 레드 엘리먼트들보다 두 배의 그린 엘리먼트들을 종종 포함한다. 도 5의 패턴에서, 블루 엘리먼트들은 열 $n-3$, $n-1$, $n+1$ 및 $n+3$ 에서 유일하게 나타난다. 레드 엘리먼트들은 열 $n-2$, n , $n+2$ 및 $n+4$ 에서 유일하게 나타난다. 그러나 그린 엘리먼트들은 모든 열 및 행에서 나타나며, 레드와 블루와 함께 산재된다.

이와 같이, 시행 블록 52에서, 이미지 센서 18에서 출력되는 레드, 블루 및 그린 이미지 데이터는 이미지 프로세싱 모듈(image processing module) 20에 의해 수신되고, 도 7에 도시된 것과 같이, 분리된 컬러 데이터 컴포넌트들로 구성될 수 있다. 도 7에서 보여지는 바와 같이, 도 4와 함께 상기에서 묘사된 것처럼, 이미지 프로세싱 모듈(image processing module) 20은 레드, 블루, 및 그린 이미지 데이터를 네 개의 분리된 컴포넌트들로 분리할 수 있다. 도 7은 두 개의 그린 컴포넌트(그린 1 및 그린 2), 블루 컴포넌트 및 레드 컴포넌트를 도시한다. 그러나 이것은 이미지 센서(image sensor) 18에서 이미지 데이터를 프로세싱하는 단지 하나의 예일 뿐이다. 부가적으로, 상기에서 주목한 바와 같이, 선택적으로, 이미지 프로세싱 모듈은 그린 이미지 데이터의 1/2를 임의적으로 또는 선택적으로 삭제할 수 있다.

시행 블록 52 이후, 플로어 차트 50은 시행블록 54로 이동할 수 있다. 시행블록 54에서, 이미지 데이터는 더 처리될 수 있다. 예를 들어, 선택적으로, 어떠한 하나 또는 모든 결과 데이터(예를 들어, 그린 1, 그린 2, 도 9의 블루 이미지 데이터 및 도 10의 레드 이미지 데이터)는 더 처리될 수 있다.

예를 들어, 이미지 데이터는 다른 방법으로 프리엠퍼시스(pre-emphasis) 되거나 처리될 수 있다. 어떠한 실시예에서, 이미지 데이터는 더욱 비선형적으로(수학적으로) 처리될 수 있다. 어떠한 압축 알고리즘은 압축 이전에 픽처 엘리먼트들 상에 그러한 선형성을 수행하는 데에서 이점을 얻는다. 그러나 다른 기술이 또한 사용될 수 있다. 예를 들어, 이미지 데이터는 선형 커브를 가지고 처리될 수 있으며, 이는 본질적으로 어떠한 엠퍼시스(emphasis)도 제공하지 않는다.

어떠한 실시예들에서, 실행 블록 54는 함수 $y=x^{0.5}$ 에 의해 정의되는 커브를 사용한 이미지 데이터를 처리할 수 있다. 어떠한 실시예들에서, 이 커브는 이미지 데이터가, 예를 들어, 한정하는 것은 아니나, 정규화된 0-1 범위에서 플로팅 포인트 데이터일 때 사용될 수 있다. 다른 실시예에서는, 예를 들어, 이미지 데이터가 12-비트데이터 일 때, 이미지는 커브 $y=(x/4095)^{0.5}$ 를 가지고 처리될 수 있다. 게다가, 이미지 데이터는 $0.01003c\#g003c\#1$ 및 $c=$ 오프셋, 어떠한 실시예에서는 0 일수 있는 $y=(x+c)^g$ 와 같은, 다른 커브를 가지고 처리될 수 있다. 또한, 로그 커브가 사용될 수 있다. 예를 들어, $y=A*\log(B*x+C)$ 여기에서 A, B 및 C 는 상수인 형태의 커브가 바람직한 결과를 제공하기 위해 선택된다. 부가적으로, 상기 커브들과 프로세스들은 잘 알려진 Rec709 감마 커브에서 이용되는 그러한 기술들과 유사하게, 블랙의 근처에서 더욱더 선형 영역을 제공하기 위해 변경될 수 있다. 이미지 데이터에 이러한 프

at n with the label (label). But such layout is arbitrarily only selected for the urbanization (illustration) purpose. Here any limitation of the invention and disclosed embodiment is not issued.

In the above case, as it pays attention. The known bayer pattern filter often includes elements drawn than blue and red elements with double. In the pattern of fig. 5, blue elements uniquely show up in the heat $n-3$, the $n-1$, and the $n+1$ and $n+3$. In red elements is the heat $n-2$, the n , and the $n+2$ and $n+4$, it uniquely shows up. But elements drawn show up in all heats and row. And it is scattered with red and blue.

In this way, the red outputted from the image sensor 18 is outputted in the trial block 52, and blue and image data drawn comprise color data components which are received with the image processing module 20 and as shown in Figure 7, are separated. As shown in it is seen in fig. 7 in the above case, as it is depicted with fig. 4. The image processing module 20 can separate red, and blue and image data drawn according to four separated components. Figure 7 shows two component (1 which it draws and 2 drawn) drawn, and the blue component and red component. But this is image data in the image sensor 18 may be referred to one example processed. Additionally, in the above case, as shown in it pays attention or 1/2 of image data which the image processing module selectively draws can be arbitrarily selectively deleted.

Thereafter the flow chart 50 can move to the trial block 54 with the trial block 52. In the trial block 54, image data can be more handled. It examples begins. Any one or all result data (1, drawn for example 2 drawn, and red image data of blue image data of fig. 9 and fig. 10) can be selectively more handled.

The example is given. Image data is to the other method the preemphasis (pre-emphasis) or it can be handled. In any embodiment, image data can be more dealt by the nonlinear (mathematically). The advantage in the performing any compression algorithm is the compression, formerly, that linearity on picture elements may be obtained. But the other technology can be moreover used. The example is given. Image data can be handled with the linear curve. And this any emphasis essentially does not provide.

The image data using the curve in which the operational block 54 is defined in any embodiments with the function $y=x$ can be processed. In any embodiment s , this curve image data give the example. It does not limit. But when being floating-point data the example can be used in normalized 0-1 range. In the other embodiment, the example is given. Image data as to the image, can be handled in 12-bit data task with the curve $y=(x/4095)$. Moreover, in image data is $0.01003c\#g003c\#1$ and $c=$ offset, and any embodiment, it can be handled with the other curve like the $y=(x+c)$ may be 0. Moreover, the log curve can be used. So that the curve of the form called the A, B and C is the constant in the $y=A*\log(B*x+C)$ activating the example is given provide the result done with desirable concerning the result is selected. Additionally, similarly it can be changed w

로세스들을 적용하는데에, 동일한 프로세스들이 모든 이미지 데이터에 적용될 수 있고, 또는 다른 프로세스가 이미지 데이터의 다른 컬러에 적용될 수 있다. 그러나 이들은 이미지 데이터를 처리하기 위해 적용되는 단순한 하나의 예시에 지나지 않으며, 커브 및 트랜스 폼이 또한 사용될 수 있다. 게다가, 이러한 프로세싱 기술들은 상기에서 주목한 것 또는 룩업 테이블(LUTs)과 같은 수학적 함수를 이용하여 적용될 수 있다. 또한, 다른 프로세스, 기술 또는 트랜스 폼은 다른 형태의 이미지 데이터, 이미지 데이터의 레코딩 동안 사용되는 다른 ISO 세팅, 온도 (이것은 노이즈 레벨에 영향을 줄 수 있다)를 위해 사용될 수 있다.

ith that technologies used in curves and the it is well k
nown Rec709 gamma curve in order to nearby more an
d more provide the linear region of black. Identical in a
djust such processes to image data processes can be
applied to all image datas. Or the other process can be
applied to the other color of image data. But it does no
t pass by through the example of the simple one in whi
ch these are applied to order to process image data. A
nd the curve and transform can be used. Moreover, it
can be applied to using the mathematical function such
as which in the above case, this processing techniques
pay attention and look up table (LUTs). Moreover, the
other process , and technology or the transform can b
e used for image data of the other form, the other ISO
setting used for the recording of image data, and the t
emperature (this can affect the noise level).

시행 블록 54 이후, 플로어차트 50은 시행블록 56으로 이동할 수 있다. 시행블록 56에서, 레드 및 블루 픽처 엘리먼트들은 변형될 수 있다. 예를 들어서, 상기에서 주목한 것처럼, 그린 이미지 데이터는 각각의 블루 및 레드 이미지 데이터 컴포넌트에서 공제될 수 있다. 어떠한 실시예들에서, 레드 또는 블루 이미지 데이터 값은 레드 또는 블루 픽처 엘리먼트에 인접한 적어도 하나의 그린 픽처 엘리먼트들의 그린 이미지 데이터 값을 추출하는 것에 의해서 변형될 수 있다. 어떠한 실시예에서, 복수의 인접한 그린 픽처 엘리먼트들의 데이터 값들의 평균값은 레드, 또는 블루 이미지 데이터 값에서 공제될 수 있다. 예를 들어서, 한정하는 것은 아니나, 2,3,4의 평균값 또는 더 많은 그린 이미지 데이터 값은 그린 픽처 엘리먼트들의 부근에서 레드 또는 블루 픽처 엘리먼트들에서 계산되고 공제될 수 있다.

Thereafter the flow chart 50 can move to the trial
block 56 with the trial block 54. In the trial block 56, re
d and blue picture elements can be changed. The exam
ple is given. In the above case, as it pays attention. I
mage data drawn can be deducted from each blue and
red image data component. In any embodiments, by th
e result of that red or the blue image data value extrac
ts the image data value drawn of at least one picture e
lements drawn adjacent to red or the blue picture elem
ent it can be changed. In any embodiment, the averag
e value of data value of the multiple adjacent picture e
lements draws can be deducted from red or the blue i
mage data value. The example is given. It does not limi
t. But it can be calculated and it be deducted from the
vicinity of feature elements which the average value of
2,3,4 or more image data value drawn draws from red o
r blue picture elements.

예를 들어서, 한정하는 것은 아니나, 도 3에 있어서 레드 엘리먼트 $R_{m-2,n-2}$ 를 위한 로(raw) 출력은 네 개의 그린 픽처 엘리먼트 $G_{m-2,n-3}$, $G_{m-1,n-2}$, $G_{m-3,n-2}$ 및 $G_{m-2,n-1}$ 에 의해 포워된다. 이와 같이, 레드 엘리먼트 $R_{m-2,n-2}$ 는 다음과 같이 포워된 그린 엘리먼트들의 평균값을 공제하는 것에 의해서 변경될 수 있다.

The example is given. It does not limit. But the furnace
(raw) output for the red element $R_{m-2,n-2}$ is surrou
nded by four picture element $G_{m-2,n-3}$ draws, $G_{m-1,n-2}$,
and $G_{m-3,n-2}$ and $G_{m-2,n-1}$ as to fig. 3.
In this way, it can be changed by subtracting the aver
age value of the element in which the red element $R_{m-2,n-2}$ is surrounded like the next drawn.

$$(1) R_{m,n} = R_{m,n} - (G_{m,n-1} + G_{m+1,n} + G_{m,n+1} + G_{m-1,n})/4$$

$$(1) R_{m,n} = R_{m,n} - (G_{m,n-1} + G_{m+1,n} + G_{m,n+1} + G_{m-1,n})/4$$

유사하게, 블루 엘리먼트들도 포워된 그린 엘리먼트들의 평균을 공제함으로써 유사한 방법으로 변형될 수 있고, 다음과 같다.

Similarly, the average of the elements in which blue
elements are surrounded drawn is made to be equal to
next, it can turn into the method which subtracts.

$$(2) B_{m+1,n+1} = R_{m+1,n+1} - (G_{m,n-1} + G_{m+2,n+1} + G_{m+1,n+2} + G_{m,n+1})/4$$

$$(2) B_{m+1,n+1} = R_{m+1,n+1} - (G_{m,n-1} + G_{m+2,n+1} + G_{m+1,n+2} + G_{m,n+1})/4$$

도 9는 오리지널 블루 로(raw) 데이터 $B_{m-1,n-1}$ 이 변형된 곳에서, 결과 블루 데이터 컴포넌트를 도시한 것으로, 새로운 값은 $B_{m-1,n-1}$ 으로 라벨되었다. (컴포넌트에 단지 하나의 값이 채워지고, 동일한 기술이 모든 블루 엘리먼트를 위해

Fig. 9 shows the result blue data component in the
place, where data $B_{m-1,n-1}$ turns into the original bl
ue (raw). And the new value was labeled to the $B_{m-1,n-1}$
$m-1,n-1$. (One value is only filled with the compon

사용될 수 있다). 유사하게, 도 10은 변형된 레드 엘리먼트 R_{m-2,n-2}가 R_{#39#m-2,n-2}로 동일화될 때, 변형된 레드 데이터 컴포넌트를 도시화한 것이다. 이 상태에서, 이미지 데이터는 #34#로(raw)#34# 데이터로 여전히 고려될 수 있다. 예를 들어서, 데이터 상에서 수행된 수학적 프로세스는 너무 완전히 리버스하여 모든 오리지널 값이 그러한 프로세스들을 리버스함에 의해서 얻어질 수 있다.

도 8에 계속하여, 시행 블록 56 이후에, 플로어 차트 50은 시행 블록 58로 이동할 수 있다. 시행 블록 58에서, 로(raw) 또는 본질적으로 로(raw) 일 수 있는 결과 데이터는 어떠한 알려진 압축 알고리즘을 이용하여 더 압축될 수 있다. 예를 들어서, 압축 모듈(compression module) 22(도 1)은 그러한 압축 알고리즘을 수행하기 위해 구성될 수 있다. 압축 이후에, 압축된 로(raw) 데이터는 스토리지 디바이스 24(도 1)에 저장될 수 있다.

도 8A는 플로어차트의 변형을 도시한 것으로, 참조 번호 50#39#로 나타난다. 플로어차트 50과 관련하여 상기에서 묘사된 어떠한 단계는 플로어차트 50#39#의 몇몇 대응되는 단계와 유사하거나 동일하고, 따라서 같은 참조번호로 인용된다.

도 8A에서 보여지는 바와 같이, 어떠한 실시예들에서, 플로어차트 50#39#는 실행 블록 54를 선택적으로 생략할 수 있다. 어떠한 실시예들에서, 플로어차트 50#39#는 룩업 테이블이 이미지 데이터에 적용될 수 있는 실행 블록 57을 또한 포함할 수 있다. 예를 들어서, 도 11의 커브에 의해서 대표되는, 선택적인 룩-업 테이블은 다른 압축을 향상시키기 위해 사용될 수 있다. 어떠한 실시예들에서, 룩-업 테이블은 레드 및 블루 픽처 엘리먼트들을 위해 또한 사용될 수 있다. 동일한 룩-업 테이블은 세 개의 다른 컬러를 위해 사용될 수 있거나, 각각의 컬러가 자신의 룩-업 테이블을 가질 수도 있다. 게다가, 도 11의 커브에 의해서 대표되는 것 이외의 다른 프로세스들이 또한 적용될 수 있다.

도 8 및 도 8A와 관련하여 상기에서 묘사된 방법에서 이미지 데이터를 프로세싱하는 것에 의해서, 이미지 센서 18에서의 이미지 데이터가 6:1의 압축비 또는 그보다 더 높은 비율에 의해서 압축될 수 있고, 외형적으로 손실 없이 존재하는 것이 발견되었다. 부가적으로, 이미지 데이터는 변형되었을 지라도(예, 그린 이미지 데이터의 공제), 모든 로(raw) 이미지 데이터는 엔드 유저에서 여전히 유용하다. 예를 들어서, 어떠한 프로세스를 리버스 하는 것에 의해, 모든 또는 본질적으로 모든 오리지널 로(raw) 데이터가 추출될 수 있고, 따라서 사용자가 바라는 어떠한 프로세스를 사용하여 더 프로세스되고, 필터링 되고/되거나 디모자이크 할 수 있다.

예를 들어서, 도 12와 관련하여, 스토리지 디바이스(storage device) 24에서 저장된 데이터는 압축해제되고 디모자이크 될 수 있다. 선택적으로, 카메라 10은 플로어차트 60에 의해 도시된 방법을 수행하기 위해 구성될 수 있다. 예를 들어서, 한정하

ent. The same technology can be used for all blue elements) When the red element R_{m-2,n-2} in which similarly fig. 10 is changed is identified by the R_{#39#m-2,n-2} the transformed red data component is urbanized. In this state, image data can be still considered to the #34# (raw) to data with 34. The example is given. It mathematical the completely the process is so reversible and by reversing that processes all original values can be obtained.

And then, the flow chart 50 can move to the trial block 58 in fig. 8 after the trial block 56. In the trial block 58, as a result of maying be to the furnace (raw) or the intrinsic (raw) data can be compacted using the known compression algorithm. The example is given. The compressive module (compression module) 22 (the drawing 1) is configured to perform that compression algorithm. Furnace (raw) data compacted after compression can be stored in the storage device 24 (the drawing 1).

The drawing 8A shows the deformation of the flow chart. And it appears by the reference number 50'. Any step that in the above case, is depicted in connection with the flow chart 50 is similar to the step corresponding to of the flow chart 50' or it is identical. Therefore it is cited due to the same reference number.

As shown in it is seen in the drawing 8A the flow chart 50' selectively can omit the operational block 54 in any embodiments. It any embodiment field stands. The flow chart 50' moreover may include the operational block 57 in which the look up table can be applied to image data. The example is given. So that the look-up table improve the other compression is represented by the curve of fig. 11 the example can be used. In any embodiments, the look-up table can be moreover used for red and blue feature elements. The same look-up table has each color is its own look-up table it can be used for three other colors. Moreover, it is represented by the curve of fig. 11 the other processes of the except can be moreover applied to.

Image data was processed in the method which in the above case, was depicted in connection with figures 8 and 8A. Accordingly image data in the image sensor 18 was according to due to the compression ratio or the rate of being much higher than that of 6:1 and it could be compacted. The loss was discovered to externally exist without the loss image data were changed (the example, and the subtraction of image data drawn). So all furnace (raw) image datas are still useful in the end user the example is given. Any process is reversed. Accordingly data can be essentially extracted to all original (raw). It is therefore more processed using any process where the user hopes in their heart. It is filtered and it becomes or it can do.

The example is given. Data stored in connection with fig. 12 in the storage device 24 can be compression-released and it can be demosaiced. Selectively, the camera 10 is configured to perform the illustrated method wi

는 것은 아니나, 플레이 백 모듈(play back module) 28은 플로어차트 60에 의해 도시된 방법을 수행하기 위해 구성될 수 있다. 그러나 사용자는 또한 스토리지 디바이스(storage device) 24에서의 데이터를 분리 워크스테이션으로 또한 전달할 수 있고, 플로어차트 60의 어떤 또는 모든 단계 및/또는 동작을 시행할 수 있다.

도 12에 계속하여, 플로어차트 60은 실행 블록 62와 시작될 수 있고, 여기에서 스토리지 디바이스(storage device) 24에서의 데이터가 압축해제될 수 있다. 예를 들어, 실행블록 62에서 데이터의 압축해제는 실행 블록 58(도 8)에서 수행되는 압축 알고리즘의 역이 될 수 있다. 실행 블록 62 이후에, 플로어차트 60은 실행 블록 64로 이동할 수 있다.

실행 블록 64에서, 실행 블록 56(도 8)에서 수행된 프로세스는 거꾸로 될 수 있다. 예를 들어, 도 11의 커브의 역이나 도 8 및 도 8A의 실행 블록 56과 관련하여 묘사된 어떠한 다른 함수의 역이 이미지 데이터에 적용될 수 있다. 실행 블록 64 이후에, 플로어차트 60은 단계 66으로 이동할 수 있다.

실행 블록 66에서, 그린 픽처 엘리먼트는 디모자이크 될 수 있다. 예를 들어, 상기에서 주목한 바와 같이, 데이터 컴포넌트 그린 1 및/또는 그린 2(도 7)에서 모든 값은 스토리지 디바이스(storage device) 24에 저장될 수 있다. 예를 들어, 도 5와 관련하여, 데이터 컴포넌트 그린 1, 그린 2에서 그린 이미지 데이터는 이미지 센서(image sensor) 18에 의해 적용된 오리지널 베이어 패턴에 따라 정렬될 수 있다. 그린 데이터는 예를 들어, 선형 중첩(linear interpolation), 쌍일차 방정식(bilinear) 등과 같은 어떠한 알려진 기술에 의해 더욱더 디모자이크 될 수 있다.

도 13은 모든 로(raw) 그린 이미지 데이터에 디모자이크 된 그린 이미지 데이터의 전형적인 레이아웃을 도시하였다. 문자 Gx로 표시되는 그린 이미지 엘리먼트들은 오리지널 로(raw)(압축해제된) 이미지 데이터이고, #34#DGx#34#로 나타나는 엘리먼트들은 디모자이크 프로세싱을 통해 오리지널 데이터에서 유도된 엘리먼트들을 나타낸다. 이러한 명명은 다른 컬러를 위한 디모자이크 프로세싱의 하기 묘사에 대해서도 사용될 것이다. 도 14는 오리지널 그린 이미지 데이터의 1/2에서 디모자이크 된 그린 이미지 데이터를 위한 대표적인 이미지 데이터를 도시하였다.

도 12에 계속하여, 실행 블록 66 이후, 플로어 차트 60은 실행 블록 68로 이동할 수 있다. 실행 블록 68에서, 디모자이크된 그린 이미지 데이터는 더 프로세스될 수 있다. 예를 들어, 한정하는 것은 아니나, 노이즈 감소 기술은 그린 이미지 데이터에 적용될 수 있다. 그러나 안티앨리어싱 기술과 같은 다른 이미지 프로세싱 기술은 그린 이미지 데이터에 또한 적용될 수 있다. 실행 블록 68 이후, 플로어차트 60은 실행 블록 70으로 이동할 수 있다.

실행 블록 70에서, 레드 및 블루 이미지는 디모자이크 될 수 있다. 예를 들어, 첫 번째로, 도 9의 블루 이미지 데이터는 오리지널 베이어 패턴(도 15)에 따라 재정렬될 수 있다. 도 16에

th the flow chart 60. The example is given. It does not limit. But the play back module 28 is configured to perform the illustrated method with the flow chart 60. But the user moreover can deliver moreover, data in the storage device 24 to the separation work station. Or all steps and/or the operation can be implemented.

And then, the flow chart 60 can be initiated in fig. 12 with the operational block 62. Data in the storage device 24 can be compression-released by the here. The decompression of data in the operational block 62 the example is given becomes the reverse of the compression algorithm performed in the operational block 58 (Figure 8). The flow chart 60 can move to the operational block 64 after the operational block 62.

In the operational block 64, it can become conversely the process performed in the operational block 56 (Figure 8). The example is given. The reverse of the reverse of the curve of fig. 11 or the other function depicted in connection with the operational block 56 of figures 8 and 8A can be applied to image data. The flow chart 60 can move to 66 step after the operational block 64.

In the operational block 66, the picture element drawn can be demosaiced. The example is given. In the above case, as shown in it pays attention all values can be stored in the storage device 24 in 2 (the drawing 7) drawn and/or 1 drawn with data component. The example is given. It can be arranged according to the original Bayer pattern in which image data drawn in 1, drawn in connection with fig. 5 with data component 2 drawn are applied by the image sensor 18. Data drawing can be more and more demosaiced with for example, the known technology including the linear superposition (linear interpolation), the bilinear equation etc.

Figure 13 shows the typical layout of image data which is demosaiced in image data drawn with all furnace (raw) drawn. The image elements drawn represented by the character G x in the element which is image data to the original (raw) (it is compression-released) and appears by the " DG x ". Is original data through the demosaicing processing exhibit induced elements. This labelling will be used about below description of the demosaic processing for the other color. Figure 14 shows representative image data for image data which is demosaiced in 1/2 of image data drawn original drawn.

And then, thereafter, the flow chart 60 can move to the operational block 68 in fig. 12 with the trial block 66. In the operational block 68, demosaiced image data which it draws which can be more processed. The example is given. It does not limit. But the example can be applied to image data which the noise diminution technology draws. But it can be moreover applied to image data which the other image processing technology like the anti-aliasing technique draws. Thereafter the flow chart 60 can move to the operational block 70 with the operational block 68.

In the operational block 70, red and blue image can be demosaiced. The example is given. Blue image data of fig. 9 can be re-arranged in the first according to the or

서 보여지는 바와 같이, 서라운드링 엘리먼트는 선형 중첩(linear interpolation), 쌍일차 방정식(bilinear) 등을 포함한 어떠한 알려진 디모자이크 기술을 사용한 존재하는 블루 이미지 데이터에서 디모자이크될 수 있다. 디모자이크 단계 결과, 도 16에서 보여지는 것처럼 모든 픽셀을 위한 블루 이미지 데이터가 존재할 수 있는데, 즉, 이는 그린 이미지 데이터 값이 공제된 블루 이미지 데이터 값이다.

실행 블록 70은 레드 이미지 데이터의 디모자이크 처리를 또한 포함할 수 있다. 예를 들어, 도 10에서 레드 이미지 데이터는 선형 중첩(linear interpolation), 쌍일차 방정식(bilinear) 등과 같은 어떤 알려진 디모자이크 프로세스에 의해 더 디모자이크될 수 있고, 오리지널 베이어 패턴에 따라 재정렬될 수 있다.

실행 블록 70 이후, 플로어차트는 실행 블록 72로 이동할 수 있다. 실행 블록 72에서, 디모자이크된 레드 및 블루 이미지는 디모자이크된 그린 이미지 데이터에서 재구성될 수 있다.

어떤 실시예들에서, 각각의 레드 및 블루 이미지 데이터 엘리먼트는 동일위치(co-sited) 그린 이미지 엘리먼트(동일한 행 #34#m#34# 및 열 #34#n#34# 위치에서의 그린 이미지 엘리먼트)에서의 그린 값에 추가에 의해서 재구성될 수 있다. 예를 들어, 디모자이크 이후에, 블루 이미지 데이터는 블루 엘리먼트 값 $DB_{m-2,n-2}$ 를 포함한다. 도 3의 오리지널 베이어 패턴은 이러한 위치에서 블루 엘리먼트를 포함하지 않았기 때문에, 이러한 블루 값 $DB_{m-2,n-2}$ 은 예를 들어, 엘리먼트들 $B_{m-3,n-3}$, $B_{m-1,n-3}$, $B_{m-3,n-1}$ 및 $B_{m-1,n-1}$ 의 어느 엘리먼트들에서 블루의 값에 기초하거나, 어떠한 다른 기술 또는 다른 블루 이미지 엘리먼트들에 의해서 상기 주목한 디모자이크 프로세스를 통하여 유도되었다. 상기에서 주목한 것과 같이, 이러한 값들은 실행 블록 54(도 8)에서 변형되고, 따라서 이미지 센서 18에 의해 검출된 오리지널 블루 이미지 데이터에 대응하지 않는다. 오히려, 평균 그린 값은 각각의 이들의 값에서 공제되었었다. 따라서, 결과 블루 이미지 데이터 $DB_{m-2,n-2}$ 는 그린 이미지 데이터가 공제되었던 블루 데이터를 또한 나타낸다. 따라서, 하나의 실시예들에서, 엘리먼트 $DG_{m-2,n-2}$ 를 위한 디모자이크된 그린 이미지 데이터는 블루 이미지 값 $DB_{m-2,n-2}$ 에 부가될 수 있고, 그 결과 재구성된 블루 이미지 데이터 값을 제공한다.

어떠한 실시예들에서, 선택적으로 블루 및/또는 레드 이미지 데이터는 디모자이크 이전에 처음으로 재구성될 수 있다. 예를 들어, 변형된 블루 이미지 데이터 $B_{m-1,n-1}$ 는 서라운드링 그린 엘리먼트들의 평균값을 부가하는 것에 의해서 처음으로 재구성될 수 있다. 그 결과 오리지널 블루 이미지 데이터 $B_{m-1,n-1}$ 을 획득하거나 계산한다. 이러한 프로세스는 모든 블루 이미지 데이터 상에서 수행된다. 계속적으로, 블루 이미지 데이터는 어떠한 잘 알려진 디모자이크 기술에 의해 더욱 더 디모자이크 될 수 있다. 레드 이미지 데이터는 동일하거나 유사한 방법으로 또한 처리될 수 있다.

도 12A는 플로어차트 60의 변형을 도시하고, 참조번호 60#39#로 나타난다. 플로어차트 60과 관련하여 상기에서 묘

iginal bayer pattern (the drawing 15). It can be demosaiced in the blue image data existing using the known demosaic technology in which the surrounding elements includes the linear superposition (linear interpolation), and the bilinear equation etc it is seen in fig. 16. This it is seen in the demosaic step result, and fig. 16 may be the blue image data value in which the image data value drawn is deducted.

The operational block 70 moreover may include the demosaic processing of red image data. The example is given. Red image data can be more demosaiced in fig. 10 with the known demosaic process including the linear superposition (linear interpolation), the bilinear equation etc. The demosaic process can be re-arranged according to the original bayer pattern.

Thereafter the flow chart can move to the operational block 72 with the operational block 70. In the operational block 72, it can be re-organized in the demosaiced red and image data in which the blue image is demosaiced drawn.

In certain embodiments, it can be re-organized with the addition in the green value at image element (the image element drawn at the same row "m" and heat "n" position) which each red and blue image data element draw with the co-sited (co-sited). Blue image data after the demosaic, the example is given comprises the blue element value $D B_{m-2,n-2}$. In the it is like that position, the blue element was not included. Therefore this blue value $D B_{m-2,n-2}$ gave example. It was based on the value of blue in the element $B_{m-3,n-3}$, $B_{m-1,n-3}$, and a elements of $B_{m-1,n-1}$ and $B_{m-3,n-1}$ or it was induced with the other technology or the other blue image elements through the demosaic processing paid attention as described above. In the above case, as shown in it pays attention this values are changed in the operational block 54 (the drawing 8). It the therefore does not correspond to original blue image data detected by the image sensor 18. Rather, the average green value was deducted from each their value. Therefore, blue data in which image data which the result blue image data database $m-2,n-2$ drew were deducted is moreover shown. Therefore, in one embodiment, demosaiced image data for the element $DG_{m-2,n-2}$ drawn which can be added in the blue image value $DB_{m-2,n-2}$. The blue image data value which consequently is re-organized is provided.

In any embodiments, blue and/or red image data can be selectively previously re-organized for the first time. The example is given. By adding the average value of the elements which the transformed blue image data $B_{m-1,n-1}$ draws with surrounding it can be re-organized for the first time. Consequently, the original blue image data $B_{m-1,n-1}$ is obtained or it calculates. This process is performed on all blue image datas. Continually, blue image data can be more and more demosaiced with the well known demosaic technology. It can be moreover handled by the method it is identical or similar.

The drawing 12A represents the deformation of the flow chart 60. And it appears by the reference number

사된 몇몇 단계는 플로어 차트 60#39#의 대응되는 몇몇 단계들과 유사하거나 동일할 수 있으므로, 동일한 참조 번호로 나타낸다.

도 12A에서 보여지는 것처럼, 플로어차트 60#39#는 실행 블록 62 다음에 실행블록 68#39#를 포함할 수 있다. 실행 블록 68#39#에서, 잡음 감소 기술이 이미지 데이터 상에서 수행될 수 있다. 예를 들어서, 한정하는 것은 아니나, 잡음 감소 기술은 그린 이미지 데이터에 적용될 수 있다. 그러나 앤티-앨리어싱 기술과 같은, 어떠한 다른 이미지 프로세싱 기술이 그린 이미지 데이터에 또한 적용될 수 있다. 실행 블록 68#39# 이후, 플로어차트는 실행 블록 70#39#로 이동할 수 있다.

실행 블록 70#39#에서, 이미지 데이터는 디모자이크 될 수 있다. 실행 블록 66 및 70과 관련하여 상기에서 설명한 기술에서, 그린, 레드 및 블루 이미지 데이터는 두 단계에서 디모자이크될 수 있다. 그러나 현재 플로어 차트 60#39#에서는, 상기에서 묘사된 동일한 디모자이크 기술이 이 디모자이크 프로세스를 위해 사용될지라도, 이미지 데이터의 모든 세 가지 컬러의 디모자이크가 단일 단계로 나타날 수 있다. 실행 블록 70#39# 이후, 플로어 차트는 레드 및 블루 이미지 데이터가 재구성되는 실행 블록 72로 이동할 수 있고, 역 룩-업 테이블이 적용될 수 있는 실행 블록 64로 이동할 수 있다.

이미지 데이터가 플로어 차트 70 또는 70#39# 중의 어느 하나 혹은 어떠한 다른 적당한 프로세스에 따라 압축해제되고 프로세스 된 이후, 이미지 데이터는 디모자이크된 이미지 데이터와 같이 더 프로세스 될 수 있다.

레드 및 블루 이미지 데이터를 재구성하기 이전에 그린 이미지 데이터를 디모자이크 하는 것에 의해서, 어떠한 다른 이점이 수행될 수 있다. 예를 들어서, 상기에서 주목한 것처럼, 인간의 눈은 그린 광에 더욱 민감하다. 그린 이미지 데이터를 디모자이크하고 프로세싱하는 것은 인간의 눈이 더욱 민감한 그린 이미지 값을 최적화하는 것이다. 따라서, 레드 및 블루 이미지 데이터의 연속적인 재구성은 그린 이미지 데이터의 프로세싱에 의해 영향을 받을 수 있다.

게다가, 베이어 패턴은 레드 및 블루 엘리먼트들 보다 두 배의 그린 엘리먼트를 가진다. 이와 같이, 모든 그린 데이터가 유지되는 실시예들에서는, 레드 또는 블루 이미지 데이터 엘리먼트들 중 하나와 비교하여 두 배의 그린 엘리먼트를 위한 이미지 데이터가 존재한다. 따라서, 디모자이크 기술, 필터 및 다른 이미지 프로세싱 기술은 더 나은 디모자이크, 샤프닝 또는 다른 필터된 이미지의 결과를 제공한다. 레드 및 블루 이미지 데이터를 재구성하고 디모자이크 하기 위해 이러한 디모자이크된 값들을 사용하는 것은 프로세스, 재구성, 및 레드 및 블루 엘리먼트들의 디모자이크의 고 해상도와 연관된 이점을 전달한다. 그것으로서, 결과 이미지는 더욱더 향상된다.

60'. The some step which in the above case, is depicted in connection with the flow chart 60 is similar to some steps corresponding to of the flow chart 60' or it can be identical. Therefore it shows in terms of the same reference number.

The flow chart 60' it is seen in the drawing 12A may include the operational block 68' in the operational block 62 next. In the operational block 68', the noise reduction technology can be performed on image data. The example is given. It does not limit. But the example can be applied to image data which the noise reduction technology draws. But it can be moreover applied to image data which the other image processing technology like the anti-aliasing technology, draws. Thereafter the flow chart can move to the operational block 70' with the operational block 68'.

In the operational block 70', image data can be demosaiced. In the operational block 66 and 70, in the above case, technology, green, and red and blue image data can be demosaiced in two stages. But presently, in the flow chart 60', in the above case, the depicted same demosaic technology is used for this *** zipper process. So the demosaic of all force kinds colors of image data can show up as the single step. Thereafter the flow chart can move to the operational block 72 in which red and blue image data are re-organized with the operational block 70'. It can move to the operational block 64 in which the inverse look-up table of Huffman codes can be applied to.

Image data are compression-released according to any one among the flow chart 70 or 70' or the other appropriate process and it is processed. Since then it can be more processed like image data in which image data is demosaiced.

Image data which it draws before reconstructing red and blue image data are done with demosaic. Accordingly the other advantage can be performed. The example is given. In the above case, as it pays attention. The eye of human is more sensitive to the green light. The image value in which the eye of human is more sensitive drawn is optimized to process image data drawn with the demosaic. Therefore, it can be influenced with the processing of image data which the successive reconfiguration of blue image data and red draws.

Moreover, the bayer pattern has the element drawn than red and blue elements with double. In this way, when compared with one among red or blue image data elements in the embodiment, in which data drawing are maintained, image data for the element drawn with double exists. Therefore, the demosaic in which the demosaic technology, filter, and other image processing technology are more better, and the result of the sharpen or the other filtered image are offered concerning. It processes to be to reconstruct red and blue image data and do and use demosaiced such values. The advantage related to the high resolution of the demosaic of the reconfiguration and red and blue elements is delivered. As that, the resultant image is more and more improved.

Disclaimer

본 문서는 특허 및 과학기술문헌 전용의 첨단 자동번역 시스템을 이용해 생성되었습니다. 따라서 부분적으로 오역의 가능성이 있으며, 본 문서를 자격을 갖춘 전문 번역가에 의한 번역물을 대신하는 것으로 이용되어서는 안 됩니다. 시스템 및 네트워크의 특성때문에 발생한 오역과 부분 누락, 데이터의 불일치 등에 대하여 본원은 법적인 책임을 지지 않습니다. 본 문서는 당사의 사전 동의 없이 권한이 없는 일반 대중을 위해 DB 및 시스템에 저장되어 재생, 복사, 배포될 수 없음을 알려드립니다.

(The document produced by using the high-tech machine translation system for the patent and science & technology literature. Therefore, the document can include the mistranslation, and it should not be used as a translation by a professional translator. We hold no legal liability for inconsistency of mistranslation, partial omission, and data generated by feature of system and network. We would like to inform you that the document cannot be regenerated, copied, and distributed by being stored in DB and system for unauthorized general public without our consent.)



(19) 대한민국특허청(KR)

(12) 등록특허공보(B1)

(45) 공고일자 2015년01월06일

(11) 등록번호 10-1478380

(24) 등록일자 2014년12월24일

(51) 국제특허분류(Int. Cl.)
H04N 5/225 (2006.01) H04N 5/91 (2006.01)

(21) 출원번호 10-2009-7023045

(22) 출원일자(국제) 2008년04월11일

심사청구일자 2013년04월10일

(85) 번역문제출일자 2009년11월04일

(65) 공개번호 10-2010-0016214

(43) 공개일자 2010년02월12일

(86) 국제출원번호 PCT/US2008/060126

(87) 국제공개번호 WO 2008/128112

국제공개일자 2008년10월23일

(30) 우선권주장

60/911,196 2007년04월11일 미국(US)

61/017,406 2007년12월28일 미국(US)

(56) 선행기술조사문헌

KR1020020041778 A*

US20030011747 A1*

US20030156188 A1*

*는 심사관에 의하여 인용된 문헌

(73) 특허권자

레드.컴 인코포레이티드

미국 캘리포니아주 엘바인 파커 스트리트 34 (우: 92618)

(72) 발명자

자나드, 제임스

미국 89135 네바다주 라스베가스 와일드 리지 15

나트리스, 토마스, 그레이

캐나다 케이0에이 2이0 온타리오 카스 도락 드라이브 6657

(74) 대리인

특허법인 무한

전체 청구항 수 : 총 24 항

심사관 : 한충희

(54) 발명의 명칭 비디오 카메라

(57) 요약

비디오 카메라는 외형적으로 손실 없는 방법으로 비디오 데이터를 상당히 압축하기 위해서 구성될 수 있다. 카메라는 데이터의 압축성을 향상시키는 수단으로 블루와 레드 이미지 데이터를 변형하기 위해 구성될 수 있다. 게다가, 데이터는 이러한 형태로 압축되거나 저장될 수 있다. 이것은 사용자가 디모자이크시 외형적으로는 손실 없는 오리지널 로(Raw) 데이터의 변형된 버전을 위해 오리지널 로 데이터를 얻기 위해 레드 및 블루데이터를 재구성하는 것을 가능하게 한다. 게다가, 데이터는 그런 이미지 엘리먼트들이 처음으로 디모자이크되고, 이후 레드와 블루 엘리먼트들이 디모자이크된 그런 이미지 엘리먼트들의 값에 기초하여 구성되는 방법으로 프로세스 될 수 있다.

특허청구의 범위

청구항 1

포터블 하우징;

상기 하우징에 의해 지지되고, 라이트(light)를 포커싱 하기 위해 구성된 렌즈 어셈블리;

포커싱 된 라이트(light)를 적어도 초당 23프레임의 프레임 비에서 적어도 2K의 해상력을 가지는, 상기 포커싱 된 라이트(light)의 적어도 제1, 제2 및 제3 컬러를 나타내는 로(raw) 모자이크된(mosaiced) 이미지 데이터로 변환하기 위해 구성된 라이트(light) 검출 디바이스;

메모리 디바이스; 및

외형적인 무손실을 유지하도록, 로(raw) 모자이크된 이미지 데이터를 메모리 디바이스에 압축하고 저장하기 위해 구성된 이미지 프로세싱 시스템

을 포함하고,

상기 이미지 프로세싱 시스템은 제1 평균 값을 획득하기 위해 상기 제1 컬러의 센서 셀 주위의 적어도 네 개의 센서 셀로부터 상기 제3 컬러의 이미지 데이터의 평균 값을 계산하고, 제2 평균 값을 획득하기 위해 상기 제2 컬러의 센서 셀 주위의 적어도 네 개의 센서 셀로부터 상기 제3 컬러의 이미지 데이터의 평균 값을 계산하며, 상기 제1 컬러의 상기 센서 셀로부터 상기 이미지 데이터의 값으로부터 상기 제1 평균 값을 공제(subtract)하고 상기 제2 컬러의 상기 센서 셀로부터 상기 이미지 데이터의 값으로부터 상기 제2 평균 값을 공제함으로써 상기 이미지 데이터를 변경(modify)하도록 구성되는 이미지 프로세싱 모듈을 포함하고, 상기 공제 후(following the subtraction) 상기 이미지 프로세싱 시스템은 상기 변경된 로(raw) 모자이크된 이미지 데이터를 압축하고 상기 압축된 로(raw) 모자이크된 이미지 데이터를 초당 적어도 23프레임의 비율에서 저장하도록 구성되는,

비디오 카메라.

청구항 2

삭제

청구항 3

제1항에 있어서,

상기 제 3컬러는 그린인 것을 특징으로 하는 비디오 카메라.

청구항 4

삭제

청구항 5

삭제

청구항 6

제1항에 있어서

상기 이미지 프로세싱 시스템은

상기 제 3컬러를 나타내는 이미지 데이터의 반을 삭제하기 위해 구성되는 비디오 카메라.

청구항 7

제 6항에 있어서,

상기 라이트(light) 검출 디바이스는,
제 1컬러를 검출하기 위해 구성된 센서 셀의 제 1 그룹,
제 2컬러를 검출하기 위해 구성된 센서 셀의 제 2 그룹,
제 3컬러를 검출하기 위해 구성된 센서 셀의 제 3 그룹을 포함하고,
상기 센서 셀의 제 3 그룹은 센서 셀의 제 2 그룹보다 두 배 많은 센서 셀을 포함하는 비디오 카메라.

청구항 8

제 1항에 있어서,
상기 메모리 디바이스는 하우징 내에 배열된 비디오 카메라.

청구항 9

제 1항에 있어서,
상기 메모리 디바이스는 하우징 외측상에 지지되는 비디오 카메라.

청구항 10

제 1항에 있어서,
상기 메모리 디바이스는 신축 케이블을 가지고 하우징에 연결되는 비디오 카메라.

청구항 11

제 1항에 있어서,
상기 이미지 프로세싱 시스템은 압축 이전에 로(raw) 이미지 데이터의 엔트로피를 감소하기 위하여 로(raw) 모자이크된 이미지 데이터를 조작하기 위해 구성되는 비디오 카메라.

청구항 12

제 1항에 있어서,
상기 이미지 프로세싱 시스템은 압축 이전에 로(raw) 모자이크된 이미지 데이터의 엔트로피를 감소하기 위해 구성되는 비디오 카메라.

청구항 13

삭제

청구항 14

삭제

청구항 15

삭제

청구항 16

삭제

청구항 17

삭제

청구항 18

삭제

청구항 19

제1항에 있어서,

라이트(light) 검출 디바이스는 베이어 센서를 포함하는 비디오 카메라.

청구항 20

라이트(light)를 라이트(light) 검출 소자에 유도하는 단계;

상기 라이트(light) 검출 소자에 의해 수신된 라이트(light)를 초당 23프레임보다 적어도 큰 비율에서 적어도 2k의 해상력을 가지는 적어도 제1, 제2 및 제3 컬러를 나타내는 로(raw) 모자이크된 디지털 이미지 데이터로 변형하는 단계;

상기 로(raw) 디지털 이미지 데이터가 외형적으로는 무손실을 유지하도록 상기 로(raw) 모자이크된 디지털 이미지 데이터를 압축하는 단계; 및

스토리지 디바이스 상에 초당 적어도 23프레임의 비율 및 적어도 2k의 해상력으로 로(raw) 모자이크된 디지털 이미지 데이터를 저장하는 단계를 포함하고,

상기 압축된 로(raw) 모자이크된 디지털 이미지 데이터는 본질적으로 외형적으로는 무손실을 유지하고, 하기 방법은 제1 평균 값을 획득하기 위해 상기 제1 컬러의 센서 셀에 인접한 적어도 네 개의 센서 셀로부터 상기 제3 컬러의 이미지 데이터의 평균 값을 계산하는 단계, 제2 평균 값을 획득하기 위해 상기 제2 컬러의 센서 셀에 인접한 적어도 네 개의 센서 셀로부터 상기 제3 컬러의 이미지 데이터의 평균 값을 계산하는 단계, 및 상기 제1 컬러의 상기 센서 셀로부터 상기 이미지 데이터의 값으로부터 상기 제1 평균 값을 공제하고 상기 제2 컬러의 상기 센서 셀로부터 상기 이미지 데이터의 값으로부터 상기 제2 평균 값을 공제함으로써 상기 이미지 데이터를 변경하는 단계를 포함하고, 상기 공제 후(following the subtraction) 상기 변경된 압축된 로(raw) 디지털 이미지 데이터는 상기 스토리지 디바이스 상에 저장되는,

비디오를 이용한 동영상 저장방법.

청구항 21

제 20항에 있어서,

상기 로(raw) 디지털 이미지 데이터를 압축하는 단계는

적어도 6:1의 효과적인 압축 비율로 로(raw) 디지털 이미지 데이터를 압축하는 단계를 포함하는 비디오를 이용한 동영상 저장방법.

청구항 22

제 20항에 있어서,

상기 로(raw) 이미지 데이터를 압축하는 단계는

적어도 12:1의 효과적인 압축 비율로 로(raw) 디지털 이미지 데이터를 압축하는 단계를 포함하는 비디오를 이용한 동영상 저장방법.

청구항 23

삭제

청구항 24

제 20항에 있어서,

상기 저장하는 단계는

압축된 로(raw) 모자이크된 디지털 이미지 데이터를 저장하는 단계를 포함하는 비디오를 이용한 동영상 저장방법.

청구항 25

제 20항에 있어서,

상기 저장하는 단계는

스토리지 디바이스 상에 초당 적어도 23.976의 비율로 로(raw) 모자이크된 디지털 이미지 데이터를 저장하는 단계를 포함하는 비디오를 이용한 동영상 저장방법.

청구항 26

제 20항에 있어서,

상기 저장하는 단계 이전에

로(raw) 모자이크된 디지털 이미지 데이터의 엔트로피를 감소하기 위해 로(raw) 이미지 데이터를 조작하는 단계를 더 포함하는 비디오를 이용한 동영상 저장방법.

청구항 27

제 20항에 있어서,

상기 저장하는 단계 이전에

로(raw) 모자이크된 디지털 이미지 데이터의 엔트로피를 감소하기 위한 단계를 더 포함하는 비디오를 이용한 동영상 저장방법.

청구항 28

제 27항에 있어서,

상기 엔트로피를 감소하는 단계 이후에

외형적으로 손실 없는 방법으로 로(raw) 모자이크된 디지털 이미지 데이터를 압축하는 단계를 더 포함하는 비디오를 이용한 동영상 저장방법.

청구항 29

삭제

청구항 30

제20항에 있어서,

상기 저장하는 단계는

변환 단계를 위해 사용된 라이트(light) 검출 소자를 포함하는 카메라상에 압축된 데이터를 저장하는 단계를 포함하는 비디오를 이용한 동영상 저장방법.

청구항 31

제20항에 있어서,

상기 제 3 이미지 데이터의 반을 삭제하는 단계를 더 포함하는 비디오를 이용한 동영상 저장방법.

청구항 32

삭제

청구항 33

삭제

청구항 34

제20항에 있어서,

상기 이미지 데이터는 그런 이미지 데이터를 나타내는 비디오를 이용한 동영상 저장방법.

청구항 35

제20항에 있어서,

상기 압축된 로(raw) 모자이크된 디지털 이미지 데이터와 변형된 제 1 및 제 2 이미지 데이터를 압축해제하는 단계를 더 포함하는 비디오를 이용한 동영상 저장방법.

청구항 36

제 35항에 있어서,

상기 압축해제된 디지털 이미지 데이터를 디모자이크하는 단계를 더 포함하는 비디오를 이용한 동영상 저장방법.

청구항 37

삭제

청구항 38

삭제

청구항 39

삭제

청구항 40

하우징에 의해 지지되고, 라이트(light)를 포커싱 하기 위해 구성된 렌즈 어셈블리;

포커싱된 라이트(light)를, 포커싱된 라이트(light)를 나타내고 적어도 2k의 해상력을 가지는 적어도 제1, 제2 및 제3 컬러를 나타내는 로(raw) 모자이크된 이미지 데이터의 신호로 변환하기 위해 구성된 라이트(light) 검출 디바이스;

메모리 디바이스; 및

압축해제시 상기 로(raw) 이미지 데이터가 외형적으로는 무손실을 유지하도록, 초당 적어도 23프레임의 프레임 비율(frame rate)로 로(raw) 모자이크된 이미지 데이터를 상기 메모리 디바이스에 압축하고 저장하기 위한 수단을 포함하고,

상기 압축된 로(raw) 모자이크된 디지털 이미지 데이터는 본질적으로 외형적으로는 무손실을 유지하고, 압축하고 저장하기 위한 수단은 제1 평균 값을 획득하기 위해 상기 제1 컬러의 센서 셀에 인접한 적어도 네 개의 센서 셀로부터 상기 제3 컬러의 이미지 데이터의 평균 값을 계산하고, 제2 평균 값을 획득하기 위해 상기 제2 컬러의 센서 셀에 인접한 적어도 네 개의 센서 셀로부터 상기 제3 컬러의 이미지 데이터의 평균 값을 계산하며, 상기 제1 컬러의 상기 센서 셀로부터 상기 이미지 데이터의 값으로부터 상기 제1 평균 값을 공제하고 상기 제2 컬러의 상기 센서 셀로부터 상기 이미지 데이터의 값으로부터 상기 제2 평균 값을 공제함으로써 상기 이미지 데이터를 변경하도록 구성되며, 상기 공제 후(following the subtraction) 상기 변경된 압축된 로(raw) 디지털 이미지 데이터는 스토리지 디바이스 상에 저장되는,

비디오 카메라.

청구항 41

삭제

청구항 42

삭제

청구항 43

삭제

명세서

기술분야

[0001] 본 발명은 정지 또는 동영상을 캡처하기 위한 것들과 같은 디지털카메라, 특히, 이미지를 압축하는 디지털 카메라와 같은 디지털 카메라에 관련된 것이다.

배경기술

[0002] 디지털 비디오 카메라의 유용성에도 불구하고, 주요한 동영상 제작자들과 몇몇 텔레비전 브로드캐스트 미디어는 필름 카메라에 계속하여 의존한다. 그러한 것을 위해 사용되는 필름은 비디오 에디터에게 대체 수단에 의해 편집될 수 있는 매우 고성능의 해상도 이미지를 제공한다. 그러나 최근에는 그러한 필름이 종종 스캔 되거나 디지털화 및 디지털 적으로 편집된다.

발명의 상세한 설명

[0003] 현재 이용가능한 몇몇 디지털 비디오 카메라는 고해상도 이미지 센서를 포함하고, 따라서 고 해상도 비디오를 출력하며, 그러한 카메라상에 사용되는 이미지 프로세싱 및 압축 기술은 너무 손실이 많아서, 상지에서 언급된 시장의 하이 엔드 부분들에서 허용되기에 너무나 많은 로(raw) 이미지 데이터가 제거된다. 여기에서 개시된 적어도 하나의 실시예의 관점은 메이저 동영상 시장과 같은 상지에서 주목된 시장의 하이 엔드 부분들을 위해 허용될 수 있는 비디오 길이 초당 적어도 약 23프레임의 프레임 비율과 적어도 약 2K의 해상도를 가지는 로(raw) 또는 본질적인 로(raw) 이미지 데이터를 캡처하고 저장할 수 있는 카메라에 의해 만족되는 구현을 포함한다.

[0004] 따라서, 실시예에 따라, 비디오 카메라는 포터블 하우징(portable housing) 및 하우징(housing)에 의해 지지되고 라이트를 포커싱 하기 위해 구성된 렌즈 어셈블리(lens assembly)를 포함할 수 있다. 라이트 검출 디바이스(light sensitive device)는 포커싱된 라이트를 초당 적어도 약 23프레임의 프레임 비율로, 적어도 2K의 해상도를 가지는 로(raw) 이미지 데이터로 변환하기 위해 구성될 수 있다.

[0005] 카메라는 적어도 6:1의 압축비와 외형적으로 손실 없이 존재하고, 초당 약 23프레임의 비율로 로(raw) 이미지 데이터를 메모리 디바이스(memory device)에 압축하고 저장하기 위해 구성된 이미지 프로세싱 시스템(image processing system)과 메모리 디바이스(memory device)를 또한 포함할 수 있다.

[0006] 다른 실시예에 따르면, 카메라를 이용한 동영상을 저장하는 방법은 광 검출 디바이스상(light sensitive device)에 라이트를 유도하는 단계를 포함할 수 있다. 상기 방법은 라이트 검출 소자에 의해 수신된 라이트를 초당 23프레임보다 적어도 더 큰 비율로 로(raw) 이미지 데이터를 변환하는 단계, 상기 로(raw) 이미지 디지털 이미지 데이터를 압축하는 단계 및 스토리지 디바이스(storage device)상에 초당 적어도 약 23프레임의 비율로 로(raw) 이미지 데이터를 저장하는 단계를 또한 포함할 수 있다.

[0007] 또 다른 실시예에 따르면, 비디오 카메라는 하우징(housing)에 의해 지지되고 라이트를 포커싱 하기 위한 렌즈 어셈블리(lens assembly)와 포커싱된 라이트를 포커싱된 라이트를 나타내는 로(raw) 이미지 데이터의 시그널로 변환하기 위한 라이트 검출 디바이스(light sensitive device)를 포함할 수 있다. 카메라는 메모리 디바이스(memory device)와, 초당 적어도 약 23프레임의 비율로 로(raw) 이미지 데이터를 압축하고 저장하기 위한 수단

(means)을 또한 포함할 수 있다.

[0008] 또 다른 실시예에 따르면, 비디오 카메라는 카메라의 비디오 녹화 동작 동안 사용자가 하우징의 움직임의 적어도 하나의 각도에 관련한 방향을 조작 가능하도록 구성된 적어도 하나의 핸들을 가지는 포터블 하우징(portable housing)을 포함할 수 있다. 렌즈 어셈블리(lens assembly)는 하우징(housing)에 의해 지지되고 상기 하우징(housing) 내부에 배열된 면에 라인을 포커싱 하기 위해 구성된 적어도 하나의 렌즈를 포함할 수 있다. 라인 감출 디바이스(light sensitive device)는 포커싱된 라인을 적어도 2K의 수평 해상도와 적어도 약 초당 23 프레임의 프레임 비율을 가지는 로(raw) 이미지 데이터로 변환하기 위해 구성될 수 있다. 메모리 디바이스(memory device)는 비디오 이미지 데이터를 저장하기 위해 구성될 수 있다. 이미지 프로세싱 시스템(image processing system)은 적어도 6:1의 압축비와 외형적으로는 손실 없고, 초당 적어도 약 23프레임의 비율로 로(raw) 이미지 데이터를 메모리 디바이스에 압축하고 저장하기 위해 구성될 수 있다.

[0009] 여기에서 개시된 본 발명의 적어도 하나의 다른 면은, 인간의 눈은 어떠한 다른 컬러보다 그린 과정에 매우 민감하기 때문에, 이미지 센서에서 출력되는 이미지 데이터의 변경에 기초한 그린 이미지 데이터가 데이터의 압축력을 향상시키기 위해 사용될 수 있고, 높은 질의 비디오 이미지를 제공한다. 그러한 기술은 데이터 압축 이전에 검출된 레드 및/또는 블루 라인의 크기에서 검출된 그린 라인의 크기를 공제하는 단계를 포함할 수 있다. 이것은 레드 및/또는 블루 이미지 데이터를 더 많은 압축 가능한 형태로 변환할 수 있다. 예를 들어서, 감마 수정된 RGB 데이터를 Y'CbCr로 변환하기 위한 알려진 프로세스에서, 이미지는 "비상관(decorrelated)"되고, Y'(루마(luma)라고 알려진)에서 대부분의 이미지 데이터가 남으며, 그것으로서 잔여 크로마 컴포넌트들은 더욱 압축적이다. 그러나 Y'CrCb 포맷으로 변환하기 위한 알려진 기술은 베이어 패턴 필터(Bayer pattern filter)에 바로 적용될 수 없는데, 그 이유는 각각의 컬러 데이터가 공간적으로 상관되지 않고, 베이어 패턴 필터(Bayer pattern filter)는 블루 또는 레드 이미지 데이터보다 두 배 많은 그린 이미지 데이터를 포함하기 때문이다. 여기에서 개시된 어떠한 실시예에 따르면, 그린 이미지 데이터 공제(subtraction) 단계는 이미지 데이터의 대부분이 그린 이미지 데이터에 남아있고, 잔여 데이터(remaining data)는 더욱 압축력 있는 형태로 남아 있다는 점에서 상기 주목한 Y'CbCr 변환에 유사할 수 있다.

[0010] 게다가, 그린 이미지 데이터 공제(subtraction) 단계는 가역적일 수 있고, 모든 오리진널 로(raw) 데이터를 보존할 수 있다. 따라서, 그러한 기술을 이용한 결과 시스템 및 방법은 손실 없거나 외형적으로 손실이 없고 그러한 비디오 이미지 데이터의 향상된 압축력을 제공할 수 있다.

[0011] 따라서, 실시예에 따르면, 비디오 카메라는 하우징에 의해 지지되고, 라인을 포커싱 하기 위해 구성된 렌즈 어셈블리(lens assembly)와, 포커싱 된 라인을 적어도 제 1, 제 2 및 제 3의 포커싱된 컬러로 나타내는 이미지 데이터의 로(raw) 시그널로 변환하기 위한 라인 감출 디바이스(light sensitive device)를 포함할 수 있다. 이미지 프로세싱 모듈(image processing module)은 상기 제 3컬러의 이미지 데이터에 기초한 적어도 하나의 제 1 및 제 2컬러의 이미지 데이터를 변경하기 위해 구성될 수 있다. 게다가 비디오 카메라는 메모리 디바이스(memory device) 및 제 1, 제 2 및 제 3컬러의 이미지를 압축하고, 초당 적어도 약 23프레임의 프레임 비율로 이미지 데이터를 메모리 디바이스(memory device)에 압축된 이미지 데이터를 저장하기 위해 구성된 압축 디바이스(compression device)를 포함할 수 있다.

[0012] 다른 실시예에 따르면, 이미지를 프로세싱 방법이 제공될 수 있다. 방법은 이미지 및 을 제 1컬러를 나타내는 로(raw) 제 1 이미지 데이터, 제 2컬러를 나타내는 로(raw) 제 2 이미지 데이터, 및 제 3컬러를 나타내는 로(raw) 제 3 이미지 데이터로 변환하는 단계와, 상기 로(raw) 제 3 이미지 데이터에 기초한 적어도 로(raw) 제 1 이미지 데이터 및 로(raw) 제 2 이미지 데이터를 변경하는 단계와, 로(raw) 제 3 이미지 데이터와 변경된 로(raw) 제 1 및 로(raw) 제 2 이미지 데이터를 압축하는 단계; 및 압축된 데이터를 저장하는 단계를 포함할 수 있다.

[0013] 또 다른 실시예에 따르면, 비디오 카메라는 하우징에 의해 지지되고, 라이트를 포커싱 하기 위해 구성된 렌즈 어셈블리(lens assembly)를 포함할 수 있다. 라이트 검출 디바이스(light sensitive device)는 포커싱 된 라이트를 적어도 제 1, 제2 및 제3의 포커싱된 컬러로 나타내는 이미지 데이터의 로(raw) 시그널로 변환하기 위해 구성될 수 있다. 카메라는 상기 제 3컬러의 이미지 데이터에 기초한 적어도 하나의 제 1 및 제 2컬러의 이미지 데이터를 변경하기 위한 수단(means), 메모리 디바이스(memory device); 및 제 1, 제 2 및 제 3컬러의 이미지를 압축하고, 메모리 디바이스 상에 압축된 이미지 데이터를 저장하기 위해 구성된 압축 디바이스(compression device)를 포함할 수 있다.

실시예

[0032] 도 1은 동영상을 위한 비디오 카메라와 관련하여 묘사된, 이미지 센싱(image sensing), 프로세싱(processing) 및 압축 모듈(compression module)을 가지는 카메라의 개략적인 다이어그램이다. 여기에서 개시된 실시예는 베이퍼 패턴(Bayer pattern)을 가지는 싱글 센서 디바이스를 가지는 비디오 카메라와 관련하여 묘사되는데, 그 이유는 이러한 실시예들은 이와 관련된 특별한 유용성을 가지기 때문이다. 그러나 여기에서의 실시예와 발명들은 다른 형태의 이미지 센서(예를 들어서, CMY 베이퍼 및 다른 비-베이퍼 패턴)와 다른 이미지 포맷 형태상에서 작동되고, 정지영상 및/또는 동영상을 위해 구성된 다른 수 개의 이미지 센서를 가지는 카메라들에도 또한 적용될 수 있다. 이와 같이, 여기에서 개시된 실시예들은 대표적이거나 제한되지 않은 실시예들임은 이해할 수 있으며, 따라서, 여기에서 개시된 발명들은 개시된 대표 실시예들에 의해서 제한되지 않는다.

[0033] 도 1에 연속하여, 카메라 10은 비디오 이미지 데이터를 검색, 처리 및 선택적으로 저장 및/또는 재생하기 위해 구성된 시스템 14를 지지하기 위해 형성된 바디(body) 또는 하우징(housing) 12를 포함한다. 예를 들어서, 상기 시스템 14는 옵틱 하드웨어 16(optics hardware), 이미지 센서(image sensor) 18, 이미지 프로세싱 모듈(image processing module) 20, 압축모듈(compression module) 22 및 스토리지 디바이스(storage device) 24를 포함할 수 있다. 선택적으로, 카메라 10은 모니터 모듈(monitor module) 26, 플레이 백 모듈(play back module) 28 및 디스플레이(display) 30을 또한 포함할 수 있다.

[0034] 도 2는 카메라 10의 제한되지 않은 대표적인 실시예를 도시하였다. 도 2에 서 보여지는 바와 같이, 옵틱 하드웨어(optics hardware) 16은 어느 정도 그것의 외부 표면에서 노출되도록 하는 하우징(housing) 12에 의해 지지될 수 있다. 어떤 실시예들에서, 상기 시스템 14는 하우징(housing) 12 내에서 지지될 수 있다. 예를 들어서, 이미지 센서(image sensor) 18, 이미지 프로세싱 모듈(image processing module) 20 및 압축 모듈(compression module) 22는 하우징(housing) 12 내에서 수용될 수 있다. 스토리지 디바이스(storage device) 24는 하우징 12에 마운트 될 수 있다. 부가적으로, 어떤 실시예들에서는, 스토리지 디바이스(storage device) 24는 하우징(housing) 12의 외부에 마운트 될 수 있고, 어떠한 형태의 커넥터 또는 케이블을 통하여 상기 시스템 14의 잔여 부분에 연결될 수 있다. 부가적으로, 스토리지 디바이스(storage device) 24는 신축 케이블을 가지고 상기 하우징 12에 연결될 수 있고, 따라서, 상기 스토리지 디바이스(storage device) 24가 하우징 12에서 다소 독립적으로 이동 가능하도록 한다. 예를 들어서, 그러한 신축 케이블 접속을 이용하여, 상기 스토리지 디바이스(storage device) 24는 사용자의 벨트 상에서 휴대 될 수 있고, 상기 하우징 12의 총 무게가 감소되는 것을 가능하게 한다. 또한, 다른 실시예들에서, 상기 하우징은 적어도 하나 이상의 스토리지 디바이스(storage device) 24를 내부에 포함할 수 있고, 그것의 외부에 마운트 될 수 있다. 게다가, 상기 하우징 12는 상기 모니터 모듈(monitor module) 26 및 플레이 백 모듈(play back module) 28을 지지하기 위해 제공될 수 있다. 또한, 어떤 실시예들에서는, 상기 디스플레이(display) 30은 하우징 12의 외부에 마운트(mount) 되도록 구성될 수 있다.

[0035] 상기 옵틱 하드웨어(optics hardware) 16은 유입되는 이미지를 상기 이미지 센서(image sensor) 18위에 포커싱 하기 위해서 구성된 적어도 하나의 렌즈를 가지는 렌즈 시스템의 형태로 존재할 수 있다. 선택적으로, 상기 옵틱 하드웨어(optics hardware) 16은 다양한 줌, 조리개(aperture) 및 포커스를 제공하는 멀티렌즈 시스템의 형태로 존재할 수도 있다. 게다가, 옵틱 하드웨어(optics hardware) 16은 하우징 12에 의해서 지지되고, 예를 들어서, 한정되지는 않으나, 옵틱 하드웨어(optics hardware) 16은 50-100mm(F2.8) 줌렌즈, 18-50 mm(F2.8) 줌렌즈, 300mm(F2.8) 줌렌즈, 15 mm(F2.8) 렌즈, 25mm(F1.9) 렌즈, 35mm(F1.9)렌즈, 50mm(F1.9)렌즈, 85mm(F1.9)

렌즈 및/또는 다른 렌즈를 포함하는 다양한 사이즈의 렌즈 시스템들을 수용하도록 구성된 소켓을 포함하는 복수의 다른 형태의 렌즈 시스템을 수용하기 위해 구성되는 렌즈 소켓의 형태로 존재할 수 있다. 상기에서 주목한 것처럼, 옵틱 하드웨어(optics hardware) 16은 어떠한 렌즈가 그곳에 부착됨에도 불구하고, 이미지들이 이미지 센서(image sensor) 18의 라이트 검출 표면상에 포커스 될 수 있도록 구성된다.

[0036] 이미지 센서(image sensor) 18은 어떠한 형태의 비디오 센서 디바이스가 될 수 있는데, 예를 들어서, 한정되는 것은 아니나, CCD, CMOS, Foveon® 센서, 또는 센서들 사이에 빛을 분할하기 위해 프리즘을 사용하는 멀티 센서 어레이와 같은 수직형-스택(vertically-stacked) CMOS 디바이스를 포함할 수 있다. 어떠한 실시예들에서는, 상기 이미지 센서 18은 약 1200만 포토셀을 가지는 CMOS 디바이스를 포함할 수 있다. 그러나 다른 사이즈의 센서도 사용될 수 있다. 어떠한 구성들에서는, 카메라 10은 "2K"(예를 들어, 2048 x 1152 픽셀), "4K"(예를 들어서, 4,096 x 2,540), "4.5K" 수평 해상도 또는 그 이상의 해상도로 비디오를 출력하도록 구성될 수 있다. 여기에서 사용된 것처럼, xk(상기에서 주목한 2K 및 4K와 같은)의 포맷으로 표현된 용어에서, 상기 "x" 양은 개략적인 수평 해상도를 나타낸다. 그것으로서, "4K" 해상도는 약 4000 또는 그 이상의 수평 픽셀에 대응하고, "2K"는 2000 또는 그 이상의 픽셀에 대응한다. 현재 상업적으로 가능한 하드웨어를 사용할 때, 상기 센서는 약 0.5인치(8mm)만큼 작을 수 있으나, 약 1.0인치 또는 그 이상일 수도 있다. 게다가, 상기 이미지 센서 18은 상기 센서 18의 오직 미리 결정된 부분을 선택적으로 출력하는 것에 의해서 다양한 해상도를 제공하도록 구성될 수 있다. 예를 들어서, 상기 센서 18 및/또는 상기 이미지 프로세싱 모듈(image processing module)은 사용자가 이미지 데이터 출력의 해상도를 확인하도록 구성될 수 있다.

[0037] 카메라 10은 다운샘플(downsample)하고 2K, 1080p, 720p 또는 다른 해상도로 비디오 출력을 배출하기 위해 센서 18의 출력을 연속적으로 프로세스 하기 위하여 또한 구성될 수 있다. 예를 들어서, 상기 센서 18에서 이미지 데이터는 윈도우화(windowed) 될 수 있고, 그것에 의해서 출력 이미지의 사이즈를 감소하고, 더 높은 리드 아웃 속도가 가능하게 한다. 그러나 다른 사이즈의 센서들 또한 사용될 수 있다. 게다가, 상기 카메라 10은 고 해상도에서 비디오 출력을 생산하기 위해 상기 센서 18의 출력을 업샘플(upsample)하기 위해 구성될 수 있다.

[0038] 도 1 내지 3에 있어서, 어떠한 실시예들에서는, 상기 센서 18이 베이어 패턴 필터(Bayer pattern filter)를 포함할 수 있다. 그것으로서, 그 칩셋(도면 미도시)에 의해서, 상기 센서 18은 상기 이미지 센서(image sensor) 18의 개별적인 포토셀들에 의해 검출된 레드, 그린 또는 블루 라이트의 크기를 나타내는 데이터를 출력한다. 도 3은 상기 센서 18의 베이어 패턴 출력을 개략적으로 도시하였다. 어떤 실시예들에서는, 예를 들어서, 도 3에서 보여지는 것과 같이, 상기 베이어 패턴 필터는 레드 엘리먼트들(elements)의 수와 블록 엘리먼트들(elements)의 개수보다 두 배 많은 수의 그린 엘리먼트들(elements)을 가진다. 상기 이미지 센서 18의 칩셋은 상기 이미지 센서의 각 엘리먼트상에 차지(charge)를 읽기 위해 사용될 수 있고, 따라서, 잘 알려진 RGB 포맷 출력에서 값의 스트림을 출력한다.

[0039] 도 4에 계속하여, 이미지 프로세싱 모듈(image processing module) 20은 어떠한 잘 알려진 수단에서 상기 이미지 센서(image sensor) 18에서의 데이터 스트림을 포맷하기 위해 선택적으로 구성될 수 있다. 어떠한 실시예들에서, 상기 이미지 프로세싱 모듈(image processing module) 20은 그린, 레드 및 블루 이미지 데이터를 세 개 또는 네 개의 분리 데이터 컴파일(separate data compilations)로 분해하기 위해 구성될 수 있다. 예를 들어서, 상기 이미지 프로세싱 모듈(image processing module) 20은 레드 데이터를 하나의 레드 데이터 엘리먼트로 분리, 블루 데이터를 하나의 블루 데이터 엘리먼트로 분리, 및 그린 데이터를 하나의 그린 데이터 엘리먼트로 분리하기 위해서 구성될 수 있다. 예를 들어서, 도 4에 있어서, 상기 이미지 프로세싱 모듈(image processing module) 20은 레드 데이터 프로세싱 모듈 32, 블루 데이터 이미지 프로세싱 모듈 34, 및 제 1 그린 이미지 데이터 프로세싱 모듈 36을 포함할 수 있다.

[0040] 그러나 상기에서 주목한 바와 같이, 도 3에 도시된 베이어 패턴 데이터는 다른 두 컬러보다 두 배의 많은 그린 픽셀을 가진다. 도 5는 블루와 레드 데이터가 제거된 데이터 컴포넌트(component)를 도시한 것으로, 단지 오리

지널 그린 이미지 데이터만이 남아있다.

- [0041] 어떤 실시예들에서, 상기 카메라 10은 몇몇의 그린 이미지 데이터를 삭제하거나 누락하기 위해 구성될 수 있다. 예를 들어서, 어떠한 실시예들에서는, 상기 이미지 프로세싱 모듈(image processing module) 20은 총 그린 이미지 데이터량이 블루 및 레드 이미지 데이터의 총 양과 같도록 하기 위해서 그린 이미지 데이터의 1/2를 삭제하도록 구성될 수 있다. 예를 들어서, 도 6은 상기 이미지 프로세싱 모듈(image processing module) 20이 그린 이미지 데이터의 1/2를 삭제한 후 잔여 데이터를 도시한 것이다. 도 6의 도시된 실시예에서는, n-3, n-1, n+1 및 n+3 열이 삭제되었다. 이것은 삭제될 수 있는 그린 이미지 데이터의 패턴의 하나의 전형적인 예시이다. 다른 패턴과 다른 많은 그린 이미지 데이터가 삭제될 수 있다.
- [0042] 다른 대안에서는, 상기 카메라 10이 레드 및 블루 이미지 데이터가 그린 이미지 데이터에 기초하여 변형된 후 그린 이미지 데이터의 1/2을 삭제하기 위해 구성될 수 있다. 이러한 선택적인 기술은 하기에 따라오는 다른 컬러 이미지 데이터에서 그린 이미지 데이터 값의 공제의 기술에서 묘사된다.
- [0043] 선택적으로, 상기 이미지 프로세싱 모듈(image processing module) 20은 그린 이미지 데이터를 선택적으로 삭제하기 위해서 구성될 수 있다. 예를 들어서, 상기 이미지 프로세싱 모듈(image processing module) 20은 삭제하기 위한 어떠한 그린 이미지 데이터를 선택적으로 결정하기 위해 구성된 삭제 분석 모듈(deletion analysis module)(도면 미도시)을 포함할 수 있다. 예를 들어서, 그러한 삭제 모듈(deletion module)은 그린 이미지 데이터에서 한 열의 패턴을 삭제하는 것이 모아레 라인(Moire line) 또는 다른 시각적으로 감지할 수 있는 인공엘리먼트들(artifacts)과 같은 인공엘리먼트들을 엘리어싱(aliasing)하는 결과를 만들어 낼지를 결정하기 위해서 구성될 수 있다. 삭제 모듈(deletion module)은 그러한 인공요소들을 생성하는 작은 위험을 제공하는 그린 이미지 데이터를 삭제하기 위해 선택되도록 더 구성될 수 있다. 예를 들어서, 상기 삭제 모듈(deletion module)은 그것이 상기 이미지 센서(image sensor) 18에 의해 캡처된 이미지가 복수의 평행 수평선들에 의해서 특성화된 이미지 특징(feature)을 포함하는 것을 결정한다면, 교체된 수직 행들의 그린 이미지 데이터 삭제 패턴을 선택하기 위해 구성될 수 있다. 이 삭제 패턴은 이미지에서 검출된 수평 라인들에 평행한 이미지 데이터의 변경된 라인들의 삭제 패턴에서 야기된 모아레 라인(Moire Line)과 같은 인공엘리먼트들(artifacts)을 감소하거나 제거할 수 있다.
- [0044] 그러나 이것은 삭제 모듈(deletion module)에 의해 사용될 수 있는 삭제 패턴들 이미지 특성들(features)의 하나의 제한되지 않은 예에 불과하다. 삭제 모듈(deletion module)은 예를 들어서, 이에 한정되지는 않으나, 교차열(alternating rows)의 삭제, 교차 대각선(alternating diagonal lines) 또는 다른 패턴과 같은 다른 이미지 데이터 삭제 패턴을 사용하고 다른 이미지 특성을 검출하기 위해서 구성될 수 있다. 게다가, 삭제 모듈은, 레드 및 블루 데이터 또는 사용된 센서의 형태에 의존하는 다른 이미지 데이터와 같은 그 다른 이미지 데이터의 부분을 삭제하기 위해 구성될 수 있다.
- [0045] 부가적으로, 카메라 10은 데이터 필드를 데이터 필드가 삭제된 것을 지시하는 이미지 데이터로 삽입되도록 구성될 수 있다. 예를 들어서, 한정되지는 않으나, 카메라 10은 데이터 필드를 스토리지 디바이스(storage device) 24로 저장된 어떠한 비디오 클립의 시작에 삽입하기 위해 구성될 수 있고, 이는 비디오 클립의 각 "프레임들"에서 삭제된 것을 나타낸다. 어떠한 실시예들에서, 카메라는 데이터 필드를 센서 18에 의해 캡처된 각 프레임에 삽입하기 위해 구성될 수 있고, 이는 이미지 데이터가 삭제된 것을 나타낸다. 예를 들어서, 어떤 실시예들에서는, 이미지 프로세싱 모듈(image processing module) 20이 하나의 삭제 패턴에서 그린 이미지 데이터의 1/2를 삭제하기 위해 구성되는 곳에서, 데이터 필드는 단일(single) 비트 데이터 필드만큼 작을 수 있으며, 이는 이미지 데이터가 삭제되었는지를 나타낸다. 이미지 프로세싱 모듈(image processing module) 20은 단지 하나의 패턴에서 데이터를 삭제하도록 구성되었기 때문에, 단일 비트는 데이터가 삭제되었는지를 나타내기에 충분하다.
- [0046] 어떠한 실시예들에서는, 상기에서 주목한 바와 같이, 이미지 프로세싱 모듈(image processing module) 20이 하

나의 패턴보다 더 많은 패턴에서 이미지 데이터를 선택적으로 삭제하기 위해 구성될 수 있다. 따라서, 이미지 데이터 삭제 필드는 더 커질 수 있으며, 이는 복수의 다른 이미지 데이터 삭제 패턴이 사용됨의 지시를 제공하기 위한 충분한 수의 값을 포함한다.

[0047] 이 데이터 필드는 다운스트림 컴포넌트들 및/또는 잔여 이미지 데이터가 응답하는 공간 위치를 결정하기 위한 프로세스에 의해 사용될 수 있다.

[0048] 어떠한 실시예들에서, 이미지 프로세스 모듈(image processing module)은 예를 들어서, 도 5에서 도시된 데이터와 같은, 모든 로(raw) 그린 이미지 데이터의 보유하기 위해 구성될 수 있다.

[0049] 상기에서 주목한 바와 같이, 알려진 베이어 패턴 필터에서, 레드 엘리먼트들과 블루 엘리먼트들의 수보다 두 배 많은 그린 엘리먼트들이 존재한다. 즉, 레드 엘리먼트들은 총 베이어 패턴 필터의 25%를 구성하고, 블루 엘리먼트들은 베이어 패턴 어레이의 25%에 상응되며, 그린 엘리먼트들은 베이어 패턴 어레이의 엘리먼트들의 50%를 구성한다. 이와 같이, 어떠한 실시예들에서는, 모든 그린 이미지 데이터가 보유되는 곳에서, 이미지 프로세싱 모듈(image processing module) 20이 제 2 그린 데이터 이미지 프로세싱 모듈 38을 포함할 수 있다. 그것처럼, 제 1 그린 데이터 이미지 프로세싱 모듈 36은 그린 엘리먼트들의 절반을 처리할 수 있고, 제 2 그린 데이터 이미지 프로세싱 모듈 38은 잔여 그린 엘리먼트들을 처리할 수 있다. 그러나 본 발명은 예를 들어서, 제한은 없지만, CMY 및 RGBW와 같은 다른 형태의 패턴과 함께 사용될 수 있다.

[0050] 도 7은 모듈 32, 34, 36 및 38(도 4)에 의해 프로세스 된 레드, 블루 및 두 개의 그린 데이터를 개략적으로 도시한 것을 포함한다. 이것은 그들이 거의 동일한 양의 데이터를 핸들링하므로, 이러한 모듈들의 각 크기 및 구성이 거의 같을 수 있기 때문에, 보다 유리함을 제공할 수 있다. 게다가, 이미지 프로세싱 모듈(image processing module) 20은 모든 그린 이미지 데이터(모듈 36 및 38 모두 사용에 의해)를 처리하는 모드 및 그린 데이터의 1/2가 삭제(그것은 모듈 36 및 38의 단지 하나만을 이용)하는 모드 사이에서 선택적으로 스위치 될 수 있다. 그러나 다른 구성 또한 사용 가능하다.

[0051] 부가적으로, 어떤 실시예들에서는, 이미지 프로세싱 모듈(image processing module) 20이 다른 모듈을 포함할 수 있고/있거나 예를 들어서, 제한되지는 않으나, 감마 수정 프로세스, 노이즈 필터링 프로세스 등과 같은 다른 프로세스를 수행하기 위해 구성될 수 있다.

[0052] 게다가, 어떠한 실시예들에서는, 이미지 프로세싱 모듈(image processing module) 20은 블루 엘리먼트 및/또는 레드 엘리먼트의 값에서 그린 엘리먼트의 값을 공제하기 위해 구성될 수 있다. 그것처럼, 어떠한 실시예들에서, 어떠한 컬러는 이미지 센서 18에 의해 검출될 때, 대응하는 레드 또는 블루 엘리먼트는 0으로 감소할 수 있다. 예를 들어서, 많은 사진들에서, 많은 영역의 블랙, 화이트 또는 그레이 또는 레드 또는 블루 컬러로 편향된 그레이에서 변경된 어떠한 색이 존재할 수 있다. 이와 같이, 만약 이미지 센서 18의 대응 픽셀이 그레이 영역을 검출한다면, 그린, 레드 및 블루의 크기는 거의 동일할 것이다. 이와 같이, 만약 그린 값이 레드 및 블루 값들에서 공제된다면, 레드 및 블루 값들은 0 또는 0 근처로 떨어질 것이다. 이와 같이, 연속적인 압축 프로세싱에서, 블랙, 화이트 또는 그레이 영역을 검출한 픽셀에서 생성된 많은 0 들이 존재할 것이고, 이 결과 데이터는 더욱 압축화될 것이다. 게다가, 하나 또는 두 대의 다른 컬러에서 그린의 공제는 결과 이미지 데이터가 다른 이유들에 의해 더욱 압축화 되도록 만들 것이다.

[0053] 그러한 기술은 더 높은 효율의 압축비를 달성하고, 오리지널 이미지 데이터의 엔트로피(entropy)로의 그것의 관계 때문에 외형적으로는 손실이 없게 여전히 남을 수 있도록 도울 수 있다. 예를 들어서, 이미지의 엔트로피가 이미지상에서 많은 양의 무작위와 관련된다. 예를 들어서, 다른 컬러의 이미지 데이터에서 하나의 컬러 이미지 데이터의 공제는 무작위성(randomness)을 감소할 수 있고, 따라서 그러한 컬러의 이미지 데이터의 엔트로피를

감소하며, 그것에 의해서 데이터가 적은 손실을 가지고 높은 압축비에서 압축되도록 한다. 일반적으로, 이미지는 태덤 컬러 값의 컬렉션이 아니다. 오히려, 주위(surrounding) 픽처 엘리먼트들 사이에 어떠한 정도의 상호연관성(correlation)이 종종 존재한다. 따라서, 공제기술(subtraction technique)은 더 나은 압축을 달성하기 위하여 픽처 엘리먼트의 상호연관성을 이용할 수 있다. 많은 양의 압축은, 적어도 일부분에서, 이미지상에서 오리지널 정보의 엔트로피에 의존할 것이다.

[0054] 어떠한 실시예들에서 레드 또는 블루 픽셀에서 공제된 크기는 주요 레드(subject red) 또는 블루 픽셀에 인접한 그런 픽셀에서 출력된 값의 크기가 될 수 있다. 게다가, 어떤 실시예에서는, 레드 또는 블루 픽셀에서 추출된 그런 크기는 주위 그런 엘리먼트의 평균에서 유도될 수 있다. 그러한 기술은 아래에서 더욱더 자세히 묘사될 것이다. 그러나 다른 기술도 또한 사용가능하다.

[0055] 선택적으로, 이미지 프로세싱 모듈(image processing module) 20은 다른 컬러에서 그런 이미지 데이터를 선택적으로 공제하기 위해서 구성될 수 있다. 예를 들어서, 이미지 프로세싱 모듈(image processing module) 20은 다른 컬러 중 하나의 이미지 데이터의 부분에서 그런 이미지 데이터를 공제하는 것이 더 나은 압축력을 제공할지 여부를 결정하기 위해 구성될 수 있다. 이러한 모드에서, 이미지 프로세싱 모듈(image processing module) 20은 플래그(flags)를 어떤 이미지 데이터의 부분이 변경되었는지(예를 들어, 그런 이미지 데이터 공제)와 어떤 부분이 켜 변경되지 않았는지를 나타내는 이미지 데이터 내에 삽입하기 위해 구성될 수 있다. 그러한 플래그를 가지고, 다운스트림 디모자이크/재구성(reconstruction) 컴포넌트는 그런 이미지 값을 다른 컬러의 이미지 데이터에 되돌려 선택적으로 부가할 수 있고, 이는 그러한 데이터 플래그의 상태에 기초한다.

[0056] 선택적으로, 이미지 프로세싱 모듈(image processing module) 20은 레드 및 블루 데이터의 값을 라운드(round)하기 위해 구성된 다른 데이터 감소 모듈(도면 미도시)을 또한 포함할 수 있다. 예를 들어서, 그런 크기의 추출 후에, 레드 또는 블루데이터는 거의 0이다(예를 들어서, 고해상도 시스템을 위해 0-255 또는 그 이상의 크기의 범위를 가지는 8-비트 스케일 범위 상에서 1 또는 2 이내). 예를 들어서, 센서 18은 0-4095 스케일 상에 레드, 블루 및 그런 데이터를 출력하는 12-비트 센서가 될 수 있다. 데이터의 어떠한 라운딩(rounding) 또는 필터링(filtering)은 라운딩 모듈이 바람직한 효과를 달성하도록 조정될 수 있는 것을 수행한다. 예를 들어서, 라운딩은 손실 없는 출력을 가지는 것이 바람직하다면 덜 수행될 수 있고, 어떠한 손실이나 손실 출력이 허용된다면 대부분 수행될 것이다. 어떤 라운딩은 수행될 수 있고, 여전히 외형적으로 손실 없는 출력 결과를 가진다. 예를 들어서, 8-비트 스케일 상에서, 2 또는 3까지의 절대값을 가지는 레드 또는 블루 데이터는 0으로 라운드 되고, 여전히 외형적으로 무손실 출력을 제공한다. 게다가, 12-비트 스케일에서, 10에서 20까지의 절대값을 가지는 레드 또는 블루 데이터는 0으로 라운드 될 수 있고, 여전히 외형적으로 손실 없는 출력을 제공한다.

[0057] 게다가, 0으로 라운드 될 수 있거나 다른 값으로 라운드 될 수 있는 값의 크기는 여전히 시스템의 구성에 의존하여 외형적으로 손실 없는 출력을 여전히 제공하는데, 이러한 시스템은 옴닉 하드웨어 16, 이미지 센서 18, 이미지 센서의 해상도, 이미지센서 18의 컬러 해상도(비트), 필터링 형태, 엔티-앨리어싱 기술 또는 이미지 프로세싱 모듈 20에 의해 수행되는 다른 기술, 압축 모듈 22에 의해 수행되는 압축기술 및/또는 카메라 10의 다른 파라미터 또는 특성을 포함한다.

[0058] 상에서 주목한 것처럼, 어떠한 실시예들에서, 카메라 10은 레드 및 블루 이미지 데이터가 그런 이미지 데이터에 기초하여 변형된 이후 그런 이미지 데이터의 1/2을 삭제하기 위해서 구성될 수 있다. 예를 들어서, 한정하는 것은 아니나, 프로세서 모듈 20은 주위 그런 데이터 값의 크기의 평균이 레드 및 블루 데이터 값에서 공제된 이후 그런 이미지 데이터의 1/2를 삭제하기 위해 구성될 수 있다. 그런 데이터에서 이러한 공제는 연관된 하드웨어 상에서 처리량 요구를 감소할 수 있다. 게다가, 잔여 그런 이미지 데이터는 레드와 블루 이미지 데이터를 재구성하기 위해 사용될 수 있고, 이는 도 14 내지 16과 관련한 하기에 보다 설명된다.

[0059] 상에서 주목한 것처럼, 카메라 10은 압축 모듈(compression module) 22를 또한 포함할 수 있다. 압축 모듈

(compression module) 22는 분리 칩의 형태로 존재할 수 있고, 그것은 소프트웨어나 다른 프로세서를 가지고 구현될 수 있다. 예를 들어서, 압축 모듈(compression module) 22는 JPEG2000 표준 또는 다른 압축 기술에 따른 압축 기술을 수행하는 상업적으로 이용가능한 압축 칩의 형태로 존재할 수 있다.

[0060] 압축모듈은 이미지 프로세싱 모듈(image processing module) 20에서 데이터 상의 어떠한 형태의 압축 프로세스를 수행하기 위해 구성될 수 있다. 어떠한 실시예들에서, 압축 모듈(compression module) 22는 이미지 프로세싱 모듈(image processing module) 20에 의해 수행되는 기술의 이점을 이용하는 압축 기술을 수행한다. 예를 들어서, 상기에서 주목한 것처럼, 이미지 프로세싱 모듈(image processing module) 20은 그런 이미지 데이터의 크기를 공제함으로써 레드 및 블루 데이터의 값의 크기를 감소하기 위해 구성될 수 있고, 이로 인하여, 더 큰 0의 값뿐만 아니라 다른 효과까지도 야기한다. 게다가, 이미지 프로세싱 모듈(image processing module) 20은 이미지 데이터의 엔트로피를 이용하는 로(raw) 데이터의 조작을 수행할 수 있다. 이와 같이, 압축 모듈 22에 의해 수행되는 압축 기술은 거기에서 출력된 압축된 데이터의 사이즈를 감소하기 위해 더 큰 0의 큰 스트링의 존재에서 이득을 얻는 형태일 수 있다.

[0061] 게다가, 압축모듈(compression module) 22는 외형적으로 손실 없는 출력을 야기하기 위해 이미지 프로세싱 모듈(image processing module) 20에서 이미지 데이터를 압축하기 위해 구성될 수 있다. 예를 들어서, 처음으로, 압축모듈(compression module)은, 제한은 없으나, JPEG2000, 모션JPEG, 모든 DCT 기본 코덱, 압축된 GRB 이미지 데이터를 위해 디자인된 모든 코덱, H.264, MPEG4, 호프만, 또는 다른 기술과 같은 모든 알려진 압축 기술을 적용하기 위해 구성될 수 있다.

[0062] 사용된 압축 기술의 형태에 의존하여, 압축기술의 다양한 파라미터가 외형적으로 손실 없는 출력을 제공하기 위해 배치될 수 있다. 예를 들어서, 상기에서 주목한 많은 압축 기술은 다른 압축비로 조정될 수 있고, 여기에서 압축해제될 때, 결과 이미지는 낮은 압축비를 위해 향상된 질이고, 높은 압축비를 위해서는 낮은 질이다. 이와 같이, 압축모듈은 외형적으로 손실 없는 출력을 제공하는 방법에서 이미지 데이터를 압축하기 위해서 구성될 수 있거나, 사용자가 외형적으로 손실 없는 출력을 얻기 위한 다양한 파라미터를 조정하도록 구성될 수 있다. 예를 들어서, 압축 모듈 22는 약 6:1, 7:1, 8:1 또는 그 이상의 압축비에서 이미지 데이터를 압축하도록 구성될 수 있다. 어떠한 실시예들에서, 압축 모듈 22가 12:1 또는 그 이상의 비로 이미지 데이터를 압축하기 위해 구성될 수 있다.

[0063] 게다가, 압축 모듈(compression module) 22는 사용자가 압축 모듈(compression module) 22에 의해 달성된 압축비를 조정할 수 있도록 구성될 수 있다. 예를 들어서, 카메라 10은 사용자가 압축모듈(compression module) 22가 압축비가 변하도록 하는 명령을 입력할 수 있도록 하는 유저 인터페이스를 포함할 수 있다. 이와 같이, 어떤 실시예들에서는 카메라 10이 다양한 압축을 제공할 수 있다.

[0064] 여기에서 사용된 것처럼, "외형적으로 손실 없는"이라는 용어는, 동일한 디스플레이 디바이스상에서 오리지널 이미지 데이터(압축되지 않은)를 가지고 나란히 비교될 때, 당업자 중의 하나가 이미지의 단순한 시각적인 검사에 기초하여, 어떤 이미지가 논리적인 정확도를 가지는 오리지널인지 결정할 수 없는 출력을 포함하도록 의도된다.

[0065] 도 1에 계속하여, 카메라 10은 스토리지 디바이스(storage device) 24를 또한 포함한다. 스토리지 디바이스(storage device)는 예를 들어서, 한정되지는 않으나, 하드디스크, 플래시 메모리 또는 다른 형태의 메모리 디바이스와 같은 어떤 형태의 디지털 스토리지의 형태가 될 수 있다. 어떠한 실시예들에서, 스토리지 디바이스(storage device) 24의 크기는 12 메가 픽셀 해상도, 12-비트 컬러 해상도 및 초당 60프레임에서 적어도 약 비디오의 30분에 대응하는 압축모듈 22에서 이미지 데이터를 저장하기 위해 충분히 클 수 있다. 그러나 스토리지 디바이스(storage device) 24는 어떠한 크기를 가질 수 있다.

- [0066] 어떤 실시예들에서, 스토리지 디바이스(storage device) 24가 하우징(housing) 12의 외측상에 마운트 될 수 있다. 게다가, 어떤 실시예들에서는, 스토리지 디바이스(storage device) 24가 예를 들어서, 한정되지는 않으나, IEEE1394, USB 2.0, IDE, SATA 등을 포함하는 표준 통신 포트를 통하여 시스템 14의 다른 컴포넌트들에 연결될 수 있다. 더욱이, 어떤 실시예들에서는, 스토리지 디바이스(storage device) 24는 RAID 프로토콜 상에서 운영되는 복수의 하드 드라이브를 포함할 수 있다. 그러나 어떠한 형태의 스토리지 디바이스가 사용될 수도 있다.
- [0067] 도 1에 계속하여, 상기에서 주목한 바와 같이, 어떠한 실시예들에서, 시스템은 사용자가 동작 동안 이미지 센서(image sensor) 18에 의해 캡처된 비디오 이미지를 볼 수 있도록 구성된 모니터 모듈(monitor module) 26과 디스플레이 디바이스(display device) 30을 포함할 수 있다. 어떠한 실시예들에서는, 이미지 프로세싱 모듈(image processing module) 20은 감소된 해상도 이미지 데이터를 모니터 모듈(monitor module) 26에 출력하기 위해 구성된 서브샘플링 시스템을 포함할 수 있다. 예를 들어서, 그러한 서브샘플링 시스템은 2K, 1080p, 720p 또는 다른 해상도를 지원하기 위한 미디어 이미지 데이터를 출력하기 위해 구성될 수 있다. 어떠한 실시예들에서, 디모자이크를 위해 사용된 필터는 다운샘플링 및 필터링을 또한 수행하기 위해 채용될 수 있고, 그러한 다운샘플링 및 필터링은 동시에 수행될 수 있다. 모니터 모듈(monitor module) 26은 이미지 프로세싱 모듈(image processing module) 20에서의 데이터에 어떠한 형태의 디모자이크 프로세싱을 수행하기 위해 구성될 수 있다. 그 후, 모니터 모듈(monitor module) 26은 디모자이크된 이미지 데이터를 디스플레이(display) 30에 출력할 수 있다.
- [0068] 디스플레이(display) 30은 어떠한 형태의 모니터링 디바이스일 수 있다. 예를 들어서, 한정은 아니나, 디스플레이(display) 30은 하우징(housing) 12에 의해 지지되는 4-인치 LCD 패널일 수 있다. 예를 들어서, 어떤 실시예들에서는, 디스플레이(display) 30은 사용자가 하우징(housing) 12와 관련한 어떠한 각도에서도 디스플레이(display) 30을 볼 수 있도록 하기 위해서, 디스플레이(display) 30이 하우징(housing) 12와 관련한 어떠한 위치로도 조정될 수 있도록 구성된 무한정 조정 가능한 마운트에 연결될 수 있다. 어떠한 실시예들에서, 디스플레이(display) 30은 예를 들어서, RGB 또는 YCC 포맷 비디오 케이블과 같은 어떠한 형태의 비디오 케이블을 통하여 모니터 모듈로 연결된다.
- [0069] 선택적으로, 플레이 백 모듈(play back module) 28은 스토리지 디바이스(storage device) 24에서 데이터를 수신하고, 이미지 데이터를 압축해제 및 디모자이크 하고 나서, 이미지 데이터를 디스플레이(display) 30에 출력하도록 구성될 수 있다. 어떤 실시예들에서는 모니터 모듈(monitor module) 26 및 플레이 백 모듈 (play back module) 28은 매개(intermediary) 디스플레이 컨트롤러(도면 미도시)를 통하여 디스플레이에 연결될 수 있다. 그것처럼, 디스플레이(display) 30은 디스플레이 컨트롤러에 단일커넥터를 가지고 연결될 수 있다. 디스플레이 컨트롤러는 모니터 모듈(monitor module) 26 또는 플레이 백 모듈(play back module) 28에서 디스플레이(display) 30에 데이터를 전송하기 위해 구성될 수 있다.
- [0070] 도 8은 카메라에 10에 의한 이미지 데이터의 프로세싱을 도시한 플로어 차트 50을 포함한다. 어떤 실시예들에서, 플로어 차트 50은 스토리지 디바이스(storage device) 24 또는 카메라 10 내부에 또 다른 스토리지 디바이스(도면 미도시)와 같은 메모리 디바이스에 저장된 컨트롤 루틴을 나타낼 수 있다. 게다가, 중앙 처리 장치(CPU)(도면 미도시)는 컨트롤 루틴을 수행하기 위해 구성될 수 있다. 플로어 차트 50에 대응하는 방법의 하기 기술사항은 비디오 카메라 데이터의 단일 프레임의 처리과정이 묘사된 것이다. 따라서, 그 기술은 단위 정지 이미지의 처리과정에 적용될 수 있다. 이러한 프로세스들은 12보다 큰 프레임 비율뿐만 아니라 20, 23.974, 24, 30, 60 및 120 또는 이러한 프레임 또는 더 큰 사이에 존재하는 다른 프레임 비율과 같은 연속적인 비디오의 처리과정에 또한 적용될 수 있다.
- [0071] 도 8에 계속하여, 컨트롤 루틴은 시행 블록(operation block) 52에서 시작될 수 있다. 시행 블록 52에서, 카메라 10은 센서 데이터를 획득한다. 예를 들어서, 도 1에서, 베이어 센서 및 칩셋을 포함할 수 있는 이미지 데이

터 18은 이미지 데이터를 출력할 수 있다.

[0072] 예를 들어, 한정되지는 않으나, 도 3에 있어서, 이미지 센서는 그 라이트 수신 표면상에 베이어 패턴 필터를 가지는 CMOS 디바이스를 포함할 수 있다. 이와 같이, 오픈 하드웨어 16에서 포커싱된 이미지는 이미지 센서(image sensor) 18의 CMOS 디바이스 상의 베이어 패턴 필터 상에 포커싱 된다. 도 3은 CMOS 디바이스상에 베이어 패턴 필터의 정렬에 의해서 생성된 베이어 패턴의 예를 나타낸 것이다.

[0073] 도 3에서, 열 m은 베이어 패턴의 좌측 에지에서 4번째 열이고, 열 n은 패턴의 상단에서 4번째 열이다. 나머지 행 및 열은 행 m 및 열 n과 관련하여 라벨(label)된다. 그러나 이러한 레이아웃은 도시화(illustration) 목적을 위해 임의적으로 단지 선택된 것으로, 여기에서 개시된 실시예 및 발명의 어떠한 한정도 하지 않는다.

[0074] 상기에서 주목한 것처럼, 알려진 베이어 패턴 필터는 블루 및 레드 엘리먼트들보다 두 배의 그린 엘리먼트들을 종종 포함한다. 도 5의 패턴에서, 블루 엘리먼트들은 열 n-3, n-1, n+1 및 n+3 에서 유일하게 나타난다. 레드 엘리먼트들은 열 n-2, n, n+2 및 n+4 에서 유일하게 나타난다. 그러나 그린 엘리먼트들은 모든 열 및 행에서 나타나며, 레드와 블루와 함께 산재된다.

[0075] 이와 같이, 시행 블록 52에서, 이미지 센서 18에서 출력되는 레드, 블루 및 그린 이미지 데이터는 이미지 프로세싱 모듈(image processing module) 20에 의해 수신되고, 도 7에 도시된 것과 같이, 분리된 컬러 데이터 컴포넌트들로 구성될 수 있다. 도 7에서 보여지는 바와 같이, 도 4와 함께 상기에서 묘사된 것처럼, 이미지 프로세싱 모듈(image processing module) 20은 레드, 블루, 및 그린 이미지 데이터를 네 개의 분리된 컴포넌트들로 분리할 수 있다. 도 7은 두 개의 그린 컴포넌트(그린 1 및 그린 2), 블루 컴포넌트 및 레드 컴포넌트를 도시한다. 그러나 이것은 이미지 센서(image sensor) 18에서 이미지 데이터를 프로세싱하는 단지 하나의 예일 뿐이다. 부가적으로, 상기에서 주목한 바와 같이, 선택적으로, 이미지 프로세싱 모듈은 그린 이미지 데이터의 1/2를 임의적으로 또는 선택적으로 삭제할 수 있다.

[0076] 시행 블록 52 이후, 플로어 차트 50은 시행블록 54로 이동할 수 있다. 시행블록 54에서, 이미지 데이터는 더 처리될 수 있다. 예를 들어, 선택적으로, 어떠한 하나 또는 모든 결과 데이터(예를 들어, 그린 1, 그린 2, 도 9의 블루 이미지 데이터 및 도 10의 레드 이미지 데이터)는 더 처리될 수 있다.

[0077] 예를 들어, 이미지 데이터는 다른 방법으로 프리엠퍼시스(pre-emphasis) 되거나 처리될 수 있다. 어떠한 실시예에서, 이미지 데이터는 더욱 비선형적으로(수학적으로) 처리될 수 있다. 어떠한 압축 알고리즘은 압축 이전에 픽처 엘리먼트들 상에 그러한 선형성을 수행하는 데에서 이점을 얻는다. 그러나 다른 기술이 또한 사용될 수 있다. 예를 들어, 이미지 데이터는 선형 커브를 가지고 처리될 수 있으며, 이는 본질적으로 어떠한 엠퍼시스(emphasis)도 제공하지 않는다.

[0078] 어떠한 실시예들에서, 실행 블록 54는 함수 $y=x^{0.5}$ 에 의해 정의되는 커브를 사용한 이미지 데이터를 처리할 수 있다. 어떠한 실시예들에서, 이 커브는 이미지 데이터가, 예를 들어, 한정하는 것은 아니나, 정규화된 0-1 범위에서 플로팅 포인트 데이터일 때 사용될 수 있다. 다른 실시예에서는, 예를 들어, 이미지 데이터가 12-비트 데이터 일 때, 이미지는 커브 $y=(x/4095)^{0.5}$ 를 가지고 처리될 수 있다. 게다가, 이미지 데이터는 $0.01 < g < 1$ 및 $c = \text{오프셋}$, 어떠한 실시예에서는 0 일수 있는 $y=(x+c)^g$ 와 같은, 다른 커브를 가지고 처리될 수 있다. 또한, 로그 커브가 사용될 수 있다. 예를 들어, $y=A \cdot \log(B \cdot x + C)$ 여기에서 A, B 및 C는 상수인 형태의 커브가 바람직한 결과를 제공하기 위해 선택된다. 부가적으로, 상기 커브들과 프로세스들은 잘 알려진 Rec709 감마 커브에서 이용되는 그러한 기술들과 유사하게, 블랙의 근처에서 더욱더 선형 영역을 제공하기 위해 변경될 수 있다. 이미지 데이터에 이러한 프로세스들을 적용하는데에, 동일한 프로세스들이 모든 이미지 데이터에 적용될 수 있고, 또는 다른 프로세스가 이미지 데이터의 다른 컬러에 적용될 수 있다. 그러나 이들은 이미지 데이터를 처리하기 위해

적용되는 단순한 하나의 예시에 지나지 않으며, 커브 및 트랜스 폼이 또한 사용될 수 있다. 게다가, 이러한 프로세싱 기술들은 상기에서 주목한 것 또는 룩업 테이블(LUTs)과 같은 수학적 함수를 이용하여 적용될 수 있다. 또한, 다른 프로세스, 기술 또는 트랜스 폼은 다른 형태의 이미지 데이터, 이미지 데이터의 레코딩 동안 사용되는 다른 ISO 세팅, 온도(이것은 노이즈 레벨에 영향을 줄 수 있다)를 위해 사용될 수 있다.

[0079] 시행 블록 54 이후, 플로어차트 50은 시행블록 56으로 이동할 수 있다. 시행블록 56에서, 레드 및 블루 픽처 엘리먼트들은 변형될 수 있다. 예를 들어서, 상기에서 주목한 것처럼, 그린 이미지 데이터는 각각의 블루 및 레드 이미지 데이터 컴포넌트에서 공제될 수 있다. 어떠한 실시예들에서, 레드 또는 블루 이미지 데이터 값은 레드 또는 블루 픽처 엘리먼트에 인접한 적어도 하나의 그린 픽처 엘리먼트들의 그린 이미지 데이터 값을 추출하는 것에 의해서 변형될 수 있다. 어떠한 실시예에서, 복수의 인접한 그린 픽처 엘리먼트들의 데이터 값들의 평균값은 레드, 또는 블루 이미지 데이터 값에서 공제될 수 있다. 예를 들어서, 한정하는 것은 아니나, 2,3,4의 평균값 또는 더 많은 그린 이미지 데이터 값은 그린 픽처 엘리먼트들의 부근에서 레드 또는 블루 픽처 엘리먼트들에서 계산되고 공제될 수 있다.

[0080] 예를 들어서, 한정하는 것은 아니나, 도 3에 있어서 레드 엘리먼트 $R_{m-2,n-2}$ 를 위한 로(raw) 출력은 네 개의 그린 픽처 엘리먼트 $G_{m-2,n-3}$, $G_{m-1,n-2}$, $G_{m-3,n-2}$ 및 $G_{m-2,n-1}$ 에 의해 포위된다. 이와 같이, 레드 엘리먼트 $R_{m-2,n-2}$ 는 다음과 같이 포위된 그린 엘리먼트의 평균값을 공제하는 것에 의해서 변형될 수 있다.

[0081]
$$(1) R_{m,n} = R_{m,n} - (G_{m,n-1} + G_{m+1,n} + G_{m,n+1} + G_{m-1,n})/4$$

[0082] 유사하게, 블루 엘리먼트들도 포위된 그린 엘리먼트들의 평균을 공제함으로써 유사한 방법으로 변형될 수 있고, 다음과 같다.

[0083]
$$(2) B_{m+1,n+1} = R_{m+1,n+1} - (G_{m,n-1} + G_{m+2,n+1} + G_{m+1,n+2} + G_{m,n+1})/4$$

[0084] 도 9는 오리지널 블루 로(raw) 데이터 $B_{m-1,n-1}$ 이 변형된 곳에서, 결과 블루 데이터 컴포넌트를 도시한 것으로, 새로운 값은 $B'_{m-1,n-1}$ 으로 라벨되었다. (컴포넌트에 단지 하나의 값이 채워지고, 동일한 기술이 모든 블루 엘리먼트를 위해 사용될 수 있다). 유사하게, 도 10은 변형된 레드 엘리먼트 $R_{m-2,n-2}$ 가 $R'_{m-2,n-2}$ 로 동일화될 때, 변형된 레드 데이터 컴포넌트를 도시화한 것이다. 이 상태에서, 이미지 데이터는 "로(raw)" 데이터로 여전히 고려될 수 있다. 예를 들어서, 데이터 상에서 수행된 수학적 프로세스는 너무 완전히 리버스블하여 모든 오리지널 값이 그러한 프로세스들을 리버스함에 의해서 얻어질 수 있다.

[0085] 도 8에 계속하여, 시행 블록 56 이후에, 플로어 차트 50은 시행 블록 58로 이동할 수 있다. 시행 블록 58에서, 로(raw) 또는 본질적으로 로(raw) 일 수 있는 결과 데이터는 어떠한 알려진 압축 알고리즘을 이용하여 더 압축될 수 있다. 예를 들어서, 압축 모듈(compression module) 22(도 1)는 그러한 압축 알고리즘을 수행하기 위해 구성될 수 있다. 압축 이후에, 압축된 로(raw) 데이터는 스토리지 디바이스 24(도 1)에 저장될 수 있다.

[0086] 도 8A은 플로어차트의 변형을 도시한 것으로, 참조 번호 50'로 나타난다. 플로어차트 50과 관련하여 상기에서 묘사된 어떠한 단계는 플로어차트 50'의 몇몇 대응되는 단계와 유사하거나 동일하고, 따라서 같은 참조번호로 인용된다.

- [0087] 도 8A에서 보여지는 바와 같이, 어떠한 실시예들에서, 플로어차트 50'는 실행 블록 54를 선택적으로 생략할 수 있다. 어떠한 실시예들에서, 플로어차트 50'는 룩업 테이블이 이미지 데이터에 적용될 수 있는 실행 블록 57을 또한 포함할 수 있다. 예를 들어서, 도 11의 커브에 의해서 대표되는, 선택적인 룩업 테이블은 다른 압축을 향상시키기 위해 사용될 수 있다. 어떠한 실시예들에서, 룩업 테이블은 레드 및 블루 픽처 엘리먼트들을 위해 또한 사용될 수 있다. 동일한 룩업 테이블은 세 개의 다른 컬러를 위해 사용될 수 있거나, 각각의 컬러가 자신의 룩업 테이블을 가질 수도 있다. 게다가, 도 11의 커브에 의해서 대표되는 것 이외의 다른 프로세스들이 또한 적용될 수 있다.
- [0088] 도 8 및 도 8A와 관련하여 상기에서 묘사된 방법에서 이미지 데이터를 프로세싱하는 것에 의해서, 이미지 센서 18에서의 이미지 데이터가 6:1의 압축비 또는 그보다 더 높은 비율에 의해서 압축될 수 있고, 외형적으로 손실 없이 존재하는 것이 발견되었다. 부가적으로, 이미지 데이터는 변형되었을 지라도(예, 그런 이미지 데이터의 공제), 모든 로(raw) 이미지 데이터는 엔드 유저에서 여전히 유용하다. 예를 들어서, 어떠한 프로세스를 리버스하는 것에 의해, 모든 또는 본질적으로 모든 오리지널 로(raw) 데이터가 추출될 수 있고, 따라서 사용자가 바라는 어떠한 프로세스를 사용하여 디 프로세스되고, 필터링 되고/되거나 디모자이크 할 수 있다.
- [0089] 예를 들어서, 도 12와 관련하여, 스토리지 디바이스(storage device) 24에서 저장된 데이터는 압축해제되고 디모자이크 될 수 있다. 선택적으로, 카메라 10은 플로어차트 60에 의해 도시된 방법을 수행하기 위해 구성될 수 있다. 예를 들어서, 한정하는 것은 아니나, 플레이 백 모듈(play back module) 28은 플로어차트 60에 의해 도시된 방법을 수행하기 위해 구성될 수 있다. 그러나 사용자는 또한 스토리지 디바이스(storage device) 24에서의 데이터를 분리 워크스테이션으로 또한 전달할 수 있고, 플로어차트 60의 어떤 또는 모든 단계 및/또는 동작을 시행할 수 있다.
- [0090] 도 12에 계속하여, 플로어차트 60은 실행 블록 62와 시작될 수 있고, 여기에서 스토리지 디바이스(storage device) 24에서의 데이터가 압축해제될 수 있다. 예를 들어서, 실행블록 62에서 데이터의 압축해제는 실행 블록 58(도 8)에서 수행되는 압축 알고리즘의 역이 될 수 있다. 실행 블록 62 이후에, 플로어차트 60은 실행 블록 64로 이동할 수 있다.
- [0091] 실행 블록 64에서, 실행 블록 56(도 8)에서 수행된 프로세스는 거꾸로 될 수 있다. 예를 들어서, 도 11의 커브의 역이나 도 8 및 도 8A의 실행 블록 56과 관련하여 묘사된 어떠한 다른 함수의 역이 이미지 데이터에 적용될 수 있다. 실행 블록 64 이후에, 플로어차트 60은 단계 66으로 이동할 수 있다.
- [0092] 실행 블록 66에서, 그런 픽처 엘리먼트는 디모자이크 될 수 있다. 예를 들어서, 상기에서 주목한 바와 같이, 데이터 컴포넌트 그런 1 및/또는 그런 2(도 7)에서 모든 값은 스토리지 디바이스(storage device) 24에 저장될 수 있다. 예를 들어서, 도 5와 관련하여, 데이터 컴포넌트 그런 1, 그런 2에서 그런 이미지 데이터는 이미지 센서(image sensor) 18에 의해 적용된 오리지널 베이어 패턴에 따라 정렬될 수 있다. 그런 데이터는 예를 들어, 선형 중첩(linear interpolation), 쌍일차 방정식(bilinear) 등과 같은 어떠한 알려진 기술에 의해 더욱더 디모자이크 될 수 있다.
- [0093] 도 13은 모든 로(raw) 그런 이미지 데이터에 디모자이크 된 그런 이미지 데이터의 전형적인 레이아웃을 도시하였다. 문자 G_x 로 표시되는 그런 이미지 엘리먼트들은 오리지널 로(raw)(압축해제된) 이미지 데이터이고, " DG_x "로 나타나는 엘리먼트들은 디모자이크 프로세싱을 통해 오리지널 데이터에서 유도된 엘리먼트들을 나타낸다. 이러한 명명은 다른 컬러를 위한 디모자이크 프로세싱의 하기 묘사에 대해서도 사용될 것이다. 도 14는 오리지널 그런 이미지 데이터의 1/2에서 디모자이크 된 그런 이미지 데이터를 위한 대표적인 이미지 데이터를 도시하였다.

- [0094] 도 12에 계속하여, 시행 블록 66 이후, 플로어 차트 60은 시행 블록 68로 이동할 수 있다. 시행 블록 68에서, 디모자이크된 그린 이미지 데이터는 더 프로세스될 수 있다. 예를 들어서, 한정하는 것은 아니나, 노이즈 감소 기술은 그린 이미지 데이터에 적용될 수 있다. 그러나 엔티앨리어싱 기술과 같은 다른 이미지 프로세싱 기술은 그린 이미지 데이터에 또한 적용될 수 있다. 시행 블록 68 이후, 플로어차트 60은 시행 블록 70으로 이동할 수 있다.
- [0095] 시행 블록 70에서, 레드 및 블루 이미지는 디모자이크 될 수 있다. 예를 들어서, 첫 번째로, 도 9의 블루 이미지 데이터는 오리지널 베이어 패턴(도 15)에 따라 재정렬될 수 있다. 도 16에서 보여지는 바와 같이, 서라운드 엘리먼트는 선형 중첩(linear interpolation), 쌍일차 방정식(bilinear) 등을 포함한 어떠한 알려진 디모자이크 기술을 사용한 존재하는 블루 이미지 데이터에서 디모자이크될 수 있다. 디모자이크 단계 결과, 도 16에서 보여지는 것처럼 모든 픽셀을 위한 블루 이미지 데이터가 존재할 수 있는데, 즉, 이는 그린 이미지 데이터 값이 공제된 블루 이미지 데이터 값이다.
- [0096] 시행 블록 70은 레드 이미지 데이터의 디모자이크 처리를 또한 포함할 수 있다. 예를 들어서, 도 10에서 레드 이미지 데이터는 선형 중첩(linear interpolation), 쌍일차 방정식(bilinear) 등과 같은 어떤 알려진 디모자이크 프로세스에 의해 더 디모자이크될 수 있고, 오리지널 베이어 패턴에 따라 재정렬될 수 있다.
- [0097] 시행 블록 70 이후, 플로어차트는 시행 블록 72로 이동할 수 있다. 시행 블록 72에서, 디모자이크된 레드 및 블루 이미지는 디모자이크된 그린 이미지 데이터에서 재구성될 수 있다.
- [0098] 어떤 실시예들에서, 각각의 레드 및 블루 이미지 데이터 엘리먼트는 동일위치(co-sited) 그린 이미지 엘리먼트(동일한 행 "m" 및 열 "n" 위치에서의 그린 이미지 엘리먼트)에서의 그린 값에 추가에 의해서 재구성될 수 있다. 예를 들어서, 디모자이크 이후에, 블루 이미지 데이터는 블루 엘리먼트 값 $D_{Bm-2, n-2}$ 를 포함한다. 도 3의 오리지널 베이어 패턴은 이러한 위치에서 블루 엘리먼트를 포함하지 않았기 때문에, 이러한 블루 값 $D_{Bm-2, n-2}$ 은 예를 들어서, 엘리먼트들 $B_{m-3, n-3}$, $B_{m-1, n-3}$, $B_{m-3, n-1}$ 및 $B_{m-1, n-1}$ 의 어느 엘리먼트들에서 블루의 값에 기초하거나, 어떠한 다른 기술 또는 다른 블루 이미지 엘리먼트들에 의해서 상기 주목한 디모자이크 프로세싱을 통하여 유도되었다. 상기에서 주목한 것과 같이, 이러한 값들은 시행 블록 54(도 8)에서 변형되고, 따라서 이미지 센서 18에 의해 검출된 오리지널 블루 이미지 데이터에 대응하지 않는다. 오히려, 평균 그린 값은 각각의 이들의 값에서 공제되었었다. 따라서, 결과 블루 이미지 데이터 $DB_{m-2, n-2}$ 는 그린 이미지 데이터가 공제되었던 블루 데이터를 또한 나타낸다. 따라서, 하나의 실시예들에서, 엘리먼트 $DG_{m-2, n-2}$ 를 위한 디모자이크된 그린 이미지 데이터는 블루 이미지 값 $DB_{m-2, n-2}$ 에 부가될 수 있고, 그 결과 재구성된 블루 이미지 데이터 값을 제공한다.
- [0099] 어떠한 실시예들에서, 선택적으로 블루 및/또는 레드 이미지 데이터는 디모자이크 이전에 처음으로 재구성될 수 있다. 예를 들어서, 변형된 블루 이미지 데이터 $B'_{m-1, n-1}$ 는 서라운드 그린 엘리먼트들의 평균값을 부가하는 것에 의해서 처음으로 재구성될 수 있다. 그 결과 오리지널 블루 이미지 데이터 $B_{m-1, n-1}$ 을 획득하거나 계산한다. 이러한 프로세스는 모든 블루 이미지 데이터 상에서 수행된다. 계속적으로, 블루 이미지 데이터는 어떠한 잘 알려진 디모자이크 기술에 의해 더욱 더 디모자이크 될 수 있다. 레드 이미지 데이터는 동일하거나 유사한 방법으로 또한 처리될 수 있다.
- [0100] 도 12A는 플로어차트 60의 변형을 도시하고, 참조번호 60'로 나타난다. 플로어차트 60과 관련하여 상기에서 묘사된 몇몇 단계는 플로어 차트 60'의 대응되는 몇몇 단계들과 유사하거나 동일할 수 있으므로, 동일한 참조 번호로 나타낸다.

[0101] 도 12A에서 보여지는 것처럼, 플로어차트 60'는 실행 블록 62 다음에 실행블록 68'를 포함할 수 있다. 실행 블록 68'에서, 줌 감소 기술이 이미지 데이터 상에서 수행될 수 있다. 예를 들어서, 한정하는 것은 아니나, 줌 감소 기술은 그린 이미지 데이터에 적용될 수 있다. 그러나 엔티-앨리어싱 기술과 같은, 어떠한 다른 이미지 프로세싱 기술이 그린 이미지 데이터에 또한 적용될 수 있다. 실행 블록 68' 이후, 플로어차트는 실행 블록 70'로 이동할 수 있다.

[0102] 실행 블록 70'에서, 이미지 데이터는 디모자이크 될 수 있다. 실행 블록 66 및 70과 관련하여 상기에서 설명한 기술에서, 그린, 레드 및 블루 이미지 데이터는 두 단계에서 디모자이크될 수 있다. 그러나 현재 플로어 차트 60'에서는, 상기에서 묘사된 동일한 디모자이크 기술이 이 디모자이크 프로세스를 위해 사용될지라도, 이미지 데이터의 모든 세 가지 컬러의 디모자이크가 단일 단계로 나타날 수 있다. 실행 블록 70' 이후, 플로어 차트는 레드 및 블루 이미지 데이터가 재구성되는 실행 블록 72로 이동할 수 있고, 역 룩-업 테이블이 적용될 수 있는 실행 블록 64로 이동할 수 있다.

[0103] 이미지 데이터가 플로어 차트 70 또는 70' 중의 어느 하나 혹은 어떠한 다른 적당한 프로세스에 따라 압축해제되고 프로세스 된 이후, 이미지 데이터는 디모자이크된 이미지 데이터와 같이 더 프로세스 될 수 있다.

[0104] 레드 및 블루 이미지 데이터를 재구성하기 이전에 그린 이미지 데이터를 디모자이크 하는 것에 의해서, 어떠한 다른 이점이 수행될 수 있다. 예를 들어서, 상기에서 주목한 것처럼, 인간의 눈은 그린 광에 더욱 민감하다. 그린 이미지 데이터를 디모자이크하고 프로세싱하는 것은 인간의 눈이 더욱 민감한 그린 이미지 값을 최적화하는 것이다. 따라서, 레드 및 블루 이미지 데이터의 연속적인 재구성은 그린 이미지 데이터의 프로세싱에 의해 영향을 받을 수 있다.

[0105] 게다가, 베이어 패턴은 레드 및 블루 엘리먼트들 보다 두 배의 그린 엘리먼트를 가진다. 이와 같이, 모든 그린 데이터가 유지되는 실시예들에서는, 레드 또는 블루 이미지 데이터 엘리먼트들 중 하나와 비교하여 두 배의 그린 엘리먼트를 위한 이미지 데이터가 존재한다. 따라서, 디모자이크 기술, 필터 및 다른 이미지 프로세싱 기술은 더 나은 디모자이크, 샤프 또는 다른 필터된 이미지의 결과를 제공한다. 레드 및 블루 이미지 데이터를 재구성하고 디모자이크 하기 위해 이러한 디모자이크된 값들을 사용하는 것은 프로세스, 재구성, 및 레드 및 블루 엘리먼트들의 디모자이크의 고 해상도와 연관된 이점을 전달한다. 그것으로서, 결과 이미지는 더욱더 향상된다.

산업상 이용 가능성

[0106] 레드 및 블루 이미지 데이터를 재구성하기 이전에 그린 이미지 데이터를 디모자이크 하는 것에 의해서, 어떠한 다른 이점이 수행될 수 있다. 예를 들어서, 상기에서 주목한 것처럼, 인간의 눈은 그린 광에 더욱 민감하다. 그린 이미지 데이터를 디모자이크하고 프로세싱하는 것은 인간의 눈이 더욱 민감한 그린 이미지 값을 최적화하는 것이다. 따라서, 레드 및 블루 이미지 데이터의 연속적인 재구성은 그린 이미지 데이터의 프로세싱에 의해 영향을 받을 수 있다.

[0107] 게다가, 베이어 패턴은 레드 및 블루 엘리먼트들 보다 두 배의 그린 엘리먼트를 가진다. 이와 같이, 모든 그린 데이터가 유지되는 실시예들에서는, 레드 또는 블루 이미지 데이터 엘리먼트들 중 하나와 비교하여 두 배의 그린 엘리먼트를 위한 이미지 데이터가 존재한다. 따라서, 디모자이크 기술, 필터 및 다른 이미지 프로세싱 기술은 더 나은 디모자이크, 샤프 또는 다른 필터된 이미지의 결과를 제공한다. 레드 및 블루 이미지 데이터를 재구성하고 디모자이크 하기 위해 이러한 디모자이크된 값들을 사용하는 것은 프로세스, 재구성, 및 레드 및 블루 엘리먼트들의 디모자이크의 고 해상도와 연관된 이점을 전달한다. 그것으로서, 결과 이미지는 더욱더 향상된다.

도면의 간단한 설명

[0014] 도 1은 실시예에 따른 하드웨어를 포함할 수 있고/있거나 비디오 이미지 데이터를 프로세싱하기 위한 방법을 수

행하도록 구성되는 시스템을 도시화한 블록도이다.

- [0015] 도 2는 도 1에 개략적으로 도시된 카메라를 위한 하우징의 임의의 실시예이다.
- [0016] 도 3은 도 1에 도시된 시스템을 사용할 수 있는 베이어 패턴 필터(Bayer Pattern Filter)를 가지는 이미지 센서의 개략적인 레이아웃이다.
- [0017] 도 4는 도 1에 도시된 시스템에서 사용될 수 있는 이미지 프로세싱 모듈의 개략적인 블록 다이어그램이다.
- [0018] 도 5는 도 3의 이미지 센서의 그린(green) 센서 셀에서의 그린 이미지 데이터의 개략적인 레이아웃이다.
- [0019] 도 6은 수개의 오리지널 그린 이미지 데이터의 선택적 삭제 프로세스 후 남은 도 5의 그린 이미지 데이터의 개략적인 레이아웃이다.
- [0020] 도 7은 도 1의 이미지 프로세싱 모듈에서 프로세싱을 위해 조직된 도 5의 레드(red), 블루(blue) 및 그린(green) 이미지 데이터의 개략적인 레이아웃이다.
- [0021] 도 8은 도 1에 도시된 시스템을 가지고 사용될 수 있는 이미지 변환(transformation) 기술을 도시한 플로어차트이다.
- [0022] 도 8A는 도 1에 도시된 시스템을 가지고 또한 사용될 수 있는 도 8의 이미지 데이터 변환 기술의 변경(modification)을 도시한 플로어 차트이다.
- [0023] 도 9는 도 8의 이미지 변환 프로세스의 결과인 블루 이미지 데이터의 개략적인 레이아웃이다.
- [0024] 도 10은 도 8의 이미지 변환 프로세스의 결과인 레드 이미지 데이터의 개략적인 레이아웃이다.
- [0025] 도 11은 감마 수정을 위해 이미지 데이터에 적용될 수 있는 대표적인 선택 변환을 도시한 것이다.
- [0026] 도 12는 이미지 데이터를 압축해제하고 디모자이크(demosaic) 하기 위한 도 1의 시스템을 가지고 사용될 수 있는 제어 루틴의 플로어 차트이다.
- [0027] 도 12A는 도 1에 도시된 시스템을 가지고 또한 사용될 수 있는 도 12의 제어 루틴의 변경을 도시한 플로어 차트이다.
- [0028] 도 13은 도 12의 플로어차트에 따른 압축해제되고 디모자이크된 그린 이미지의 개략적인 레이아웃이다.
- [0029] 도 14는 도 12의 플로어차트에 따른 압축해제되고 디모자이크된 도 13에서의 오리지널 그린 이미지 데이터의 반의 개략적인 레이아웃이다.
- [0030] 도 15는 도 12의 플로어차트에 따른 압축해제된 블루 이미지 데이터의 개략적인 레이아웃이다.
- [0031] 도 16은 도 12의 플로어차트에 따라 디모자이크된 도 15의 블루 이미지 데이터의 개략적인 레이아웃이다.

도면

도면1

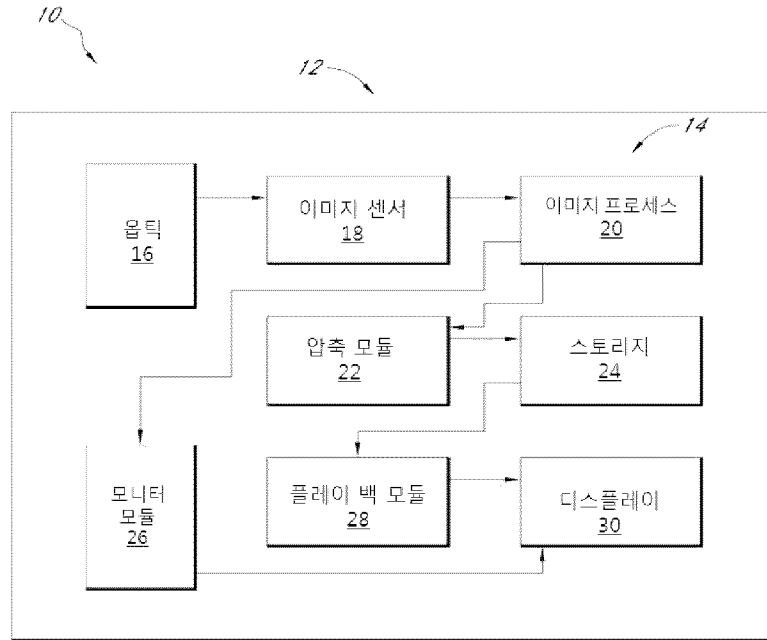

도면2

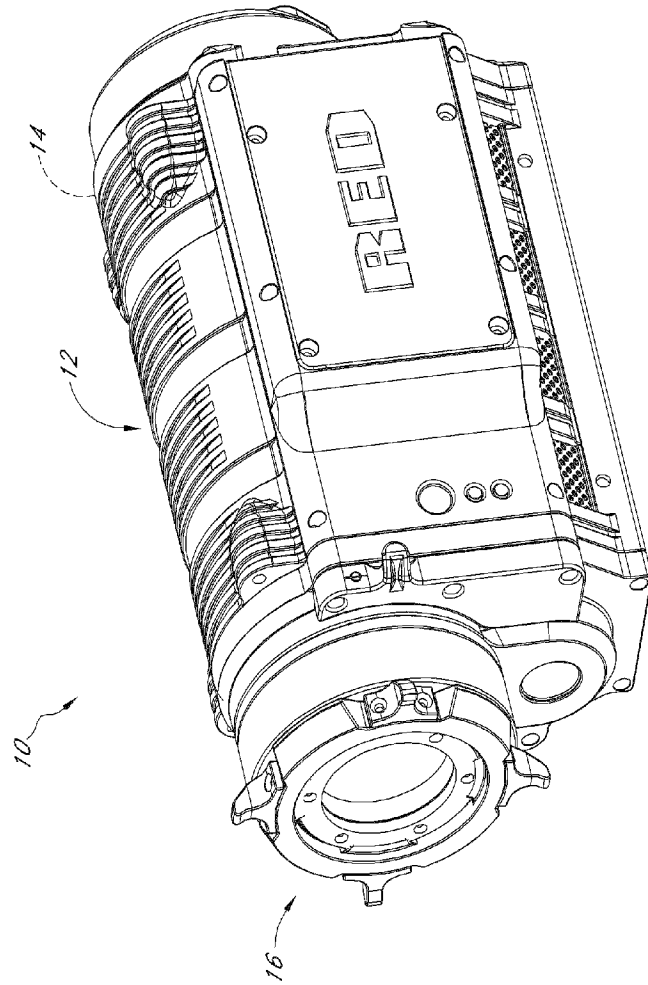

도면3

$n-3$	$m-3$	$m-2$	$m-1$	m	$m+1$	$m+2$	$m+3$	$m+4$
$n-3$	$B_{m-3,n-3}$	$G_{m-2,n-3}$	$B_{m-1,n-3}$	$G_{m,n-3}$	$B_{m+1,n-3}$	$G_{m+2,n-3}$	$B_{m+3,n-3}$	$G_{m+4,n-3}$
$n-2$	$G_{m-3,n-2}$	$R_{m-2,n-2}$	$G_{m-1,n-2}$	$R_{m,n-2}$	$G_{m+1,n-2}$	$R_{m+2,n-2}$	$G_{m+3,n-2}$	$R_{m+4,n-2}$
$n-1$	$B_{m-3,n-1}$	$G_{m-2,n-1}$	$B_{m-1,n-1}$	$G_{m,n-1}$	$B_{m+1,n-1}$	$G_{m+2,n-1}$	$B_{m+3,n-1}$	$G_{m+4,n-1}$
n	$G_{m-3,n}$	$R_{m-2,n}$	$G_{m-1,n}$	$R_{m,n}$	$G_{m+1,n}$	$R_{m+2,n}$	$G_{m+3,n}$	$R_{m+4,n}$
$n+1$	$B_{m-3,n+1}$	$G_{m-2,n+1}$	$B_{m-1,n+1}$	$G_{m,n+1}$	$B_{m+1,n+1}$	$G_{m+2,n+1}$	$B_{m+3,n+1}$	$G_{m+4,n+1}$
$n+2$	$G_{m-3,n+2}$	$R_{m-2,n+2}$	$G_{m-1,n+2}$	$R_{m,n+2}$	$G_{m+1,n+2}$	$R_{m+2,n+2}$	$G_{m+3,n+2}$	$R_{m+4,n+2}$
$n+3$	$B_{m-3,n+3}$	$G_{m-2,n+3}$	$B_{m-1,n+3}$	$G_{m,n+3}$	$B_{m+1,n+3}$	$G_{m+2,n+3}$	$B_{m+3,n+3}$	$G_{m+4,n+3}$
$n+4$	$G_{m-3,n+4}$	$R_{m-2,n+4}$	$G_{m-1,n+4}$	$R_{m,n+4}$	$G_{m+1,n+4}$	$R_{m+2,n+4}$	$G_{m+3,n+4}$	$R_{m+4,n+4}$

도면4

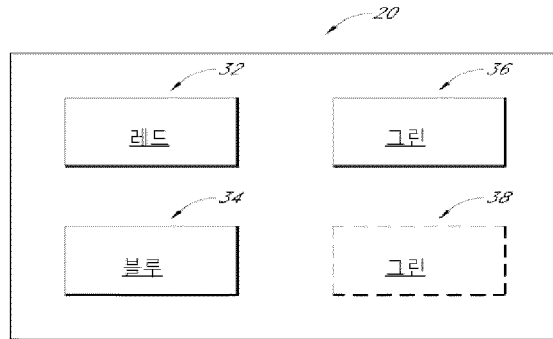

도면5

	$m-3$	$m-2$	$m-1$	m	$m+1$	$m+2$	$m+3$	$m+4$
$n-3$		$G_{m-2,n-3}$		$G_{m,n-3}$		$G_{m+2,n-3}$		$G_{m+4,n-3}$
$n-2$	$G_{m-3,n-2}$		$G_{m-1,n-2}$		$G_{m+1,n-2}$		$G_{m+3,n-2}$	
$n-1$		$G_{m-2,n-1}$		$G_{m,n-1}$		$G_{m+2,n-1}$		$G_{m+4,n-1}$
n	$G_{m-3,n}$		$G_{m-1,n}$		$G_{m+1,n}$		$G_{m+3,n}$	
$n+1$		$G_{m-2,n+1}$		$G_{m,n+1}$		$G_{m+2,n+1}$		$G_{m+4,n+1}$
$n+2$	$G_{m-3,n+2}$		$G_{m-1,n+2}$		$G_{m+1,n+2}$		$G_{m+3,n+2}$	
$n+3$		$G_{m-2,n+3}$		$G_{m,n+3}$		$G_{m+2,n+3}$		$G_{m+4,n+3}$
$n+4$	$G_{m-3,n+4}$		$G_{m-1,n+4}$		$G_{m+1,n+4}$		$G_{m+3,n+4}$	

도면6

$n-3$								
$n-2$	$C_{m-3,n-2}$		$C_{m-1,n-2}$		$C_{m+1,n-2}$		$C_{m+3,n-2}$	
$n-1$								
n	$C_{m-3,n}$		$C_{m-1,n}$		$C_{m+1,n}$		$C_{m+3,n}$	
$n+1$								
$n+2$	$C_{m-3,n+2}$		$C_{m-1,n+2}$		$C_{m+1,n+2}$		$C_{m+3,n+2}$	
$n+3$								
$n+4$	$C_{m-3,n+4}$		$C_{m-1,n+4}$		$C_{m+1,n+4}$		$C_{m+3,n+4}$	

도면7

$G_{m-2,n-3}$	$G_{m,n-3}$	$G_{m+2,n-3}$	$G_{m+4,n-3}$
$G_{m-2,n-1}$	$G_{m,n-1}$	$G_{m+2,n-1}$	$G_{m+4,n-1}$
$G_{m-2,n+1}$	$G_{m,n+1}$	$G_{m+2,n+1}$	$G_{m+4,n+1}$
$G_{m-2,n+3}$	$G_{m,n+3}$	$G_{m+2,n+3}$	$G_{m+4,n+3}$

그린 1

$G_{m-3,n-2}$	$G_{m-1,n-2}$	$G_{m+1,n-2}$	$G_{m+3,n-2}$
$G_{m-3,n}$	$G_{m-1,n}$	$G_{m+1,n}$	$G_{m+3,n}$
$G_{m-3,n+2}$	$G_{m-1,n+2}$	$G_{m+1,n+2}$	$G_{m+3,n+2}$
$G_{m-3,n+4}$	$G_{m-1,n+4}$	$G_{m+1,n+4}$	$G_{m+3,n+4}$

그린 2

$B_{m-3,n-3}$	$B_{m-1,n-3}$	$B_{m+1,n-3}$	$B_{m+3,n-3}$
$B_{m-3,n-1}$	$B_{m-1,n-1}$	$B_{m+1,n-1}$	$B_{m+3,n-1}$
$B_{m-3,n+1}$	$B_{m-1,n+1}$	$B_{m+1,n+1}$	$B_{m+3,n+1}$
$B_{m-3,n+3}$	$B_{m-1,n+3}$	$B_{m+1,n+3}$	$B_{m+3,n+3}$

블루

$R_{m-2,n-2}$	$R_{m,n-2}$	$R_{m+2,n-2}$	$R_{m+4,n-2}$
$R_{m-2,n}$	$R_{m,n}$	$R_{m+2,n}$	$R_{m+4,n}$
$R_{m-2,n+2}$	$R_{m,n+2}$	$R_{m+2,n+2}$	$R_{m+4,n+2}$
$R_{m-2,n+4}$	$R_{m,n+4}$	$R_{m+2,n+4}$	$R_{m+4,n+4}$

레드

도면8

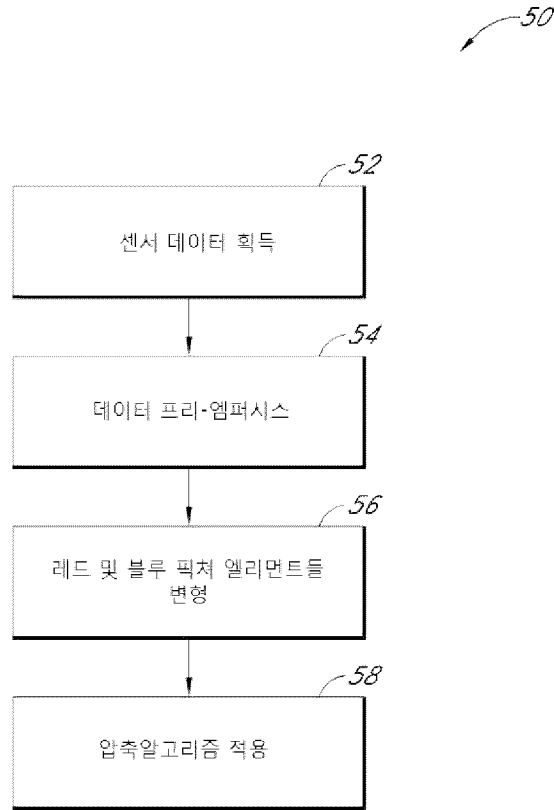

도면8A

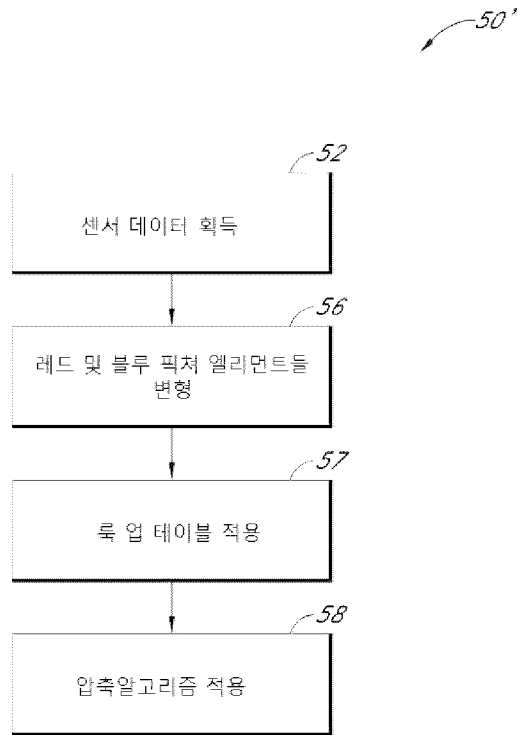

도면9

	$B'_{n-1, n-1} = \frac{B_{n-1, n-1} + (G_{m-1, n-2} + G_{m, n-1} + G_{m-1, n} + G_{m-2, n-1})/4}{4}$		

도면10

	$R'_{m-2, n-2} = \frac{R_{m-2, n-2} + (C_{m-2, n-3} + C_{m-1, n-2} + C_{m-2, n-1} + C_{m-3, n-2})/4}{4}$		

도면11

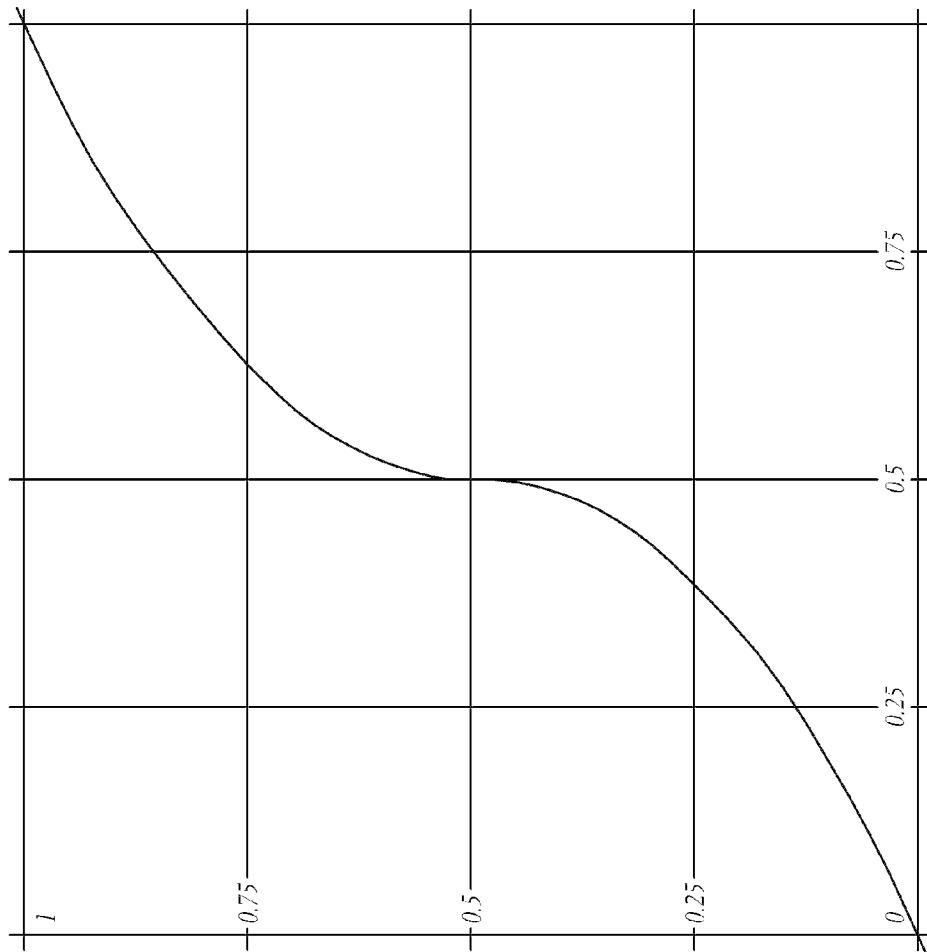

도면12

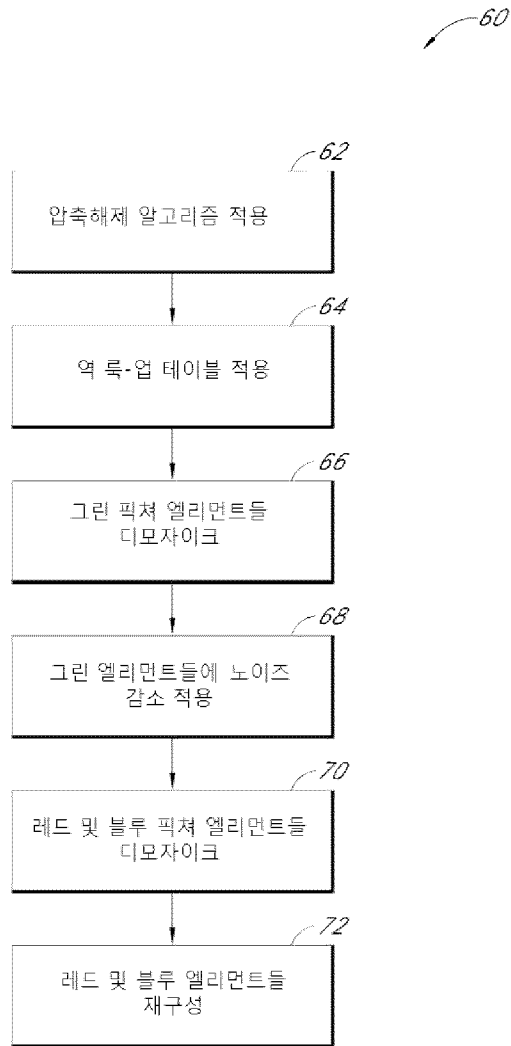

도면12A

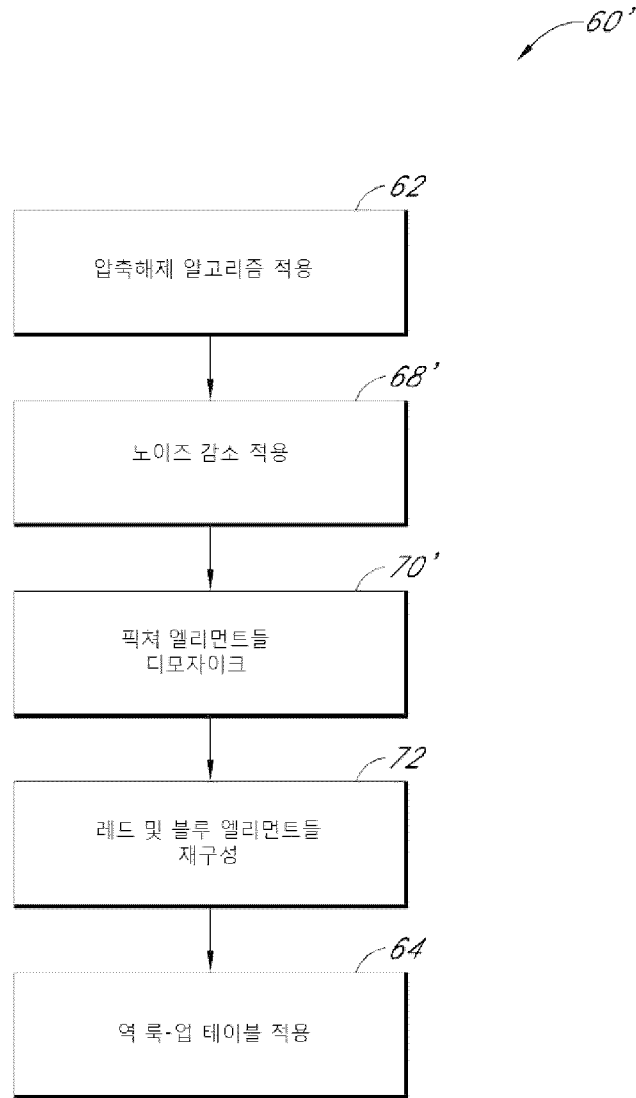

도면13

	$m-3$	$m-2$	$m-1$	m	$m+1$	$m+2$	$m+3$	$m+4$
$n-3$	$DG_{m-3,n-3}$	$G_{m-2,n-3}$	$DG_{m-1,n-3}$	$G_{m,n-3}$	$DG_{m+1,n-3}$	$G_{m+2,n-3}$	$DG_{m+3,n-3}$	$G_{m+4,n-3}$
$n-2$	$G_{m-3,n-2}$	$DG_{m-2,n-2}$	$G_{m-1,n-2}$	$DG_{m,n-2}$	$G_{m+1,n-2}$	$DG_{m+2,n-2}$	$G_{m+3,n-2}$	$DG_{m+4,n-2}$
$n-1$	$DG_{m-3,n-1}$	$G_{m-2,n-1}$	$DG_{m-1,n-1}$	$G_{m,n-1}$	$DG_{m+1,n-1}$	$G_{m+2,n-1}$	$DG_{m+3,n-1}$	$G_{m+4,n-1}$
n	$G_{m-3,n}$	$DG_{m-2,n}$	$G_{m-1,n}$	$DG_{m,n}$	$G_{m+1,n}$	$DG_{m+2,n}$	$G_{m+3,n}$	$DG_{m+4,n}$
$n+1$	$DG_{m-3,n+1}$	$G_{m-2,n+1}$	$DG_{m-1,n+1}$	$G_{m,n+1}$	$DG_{m+1,n+1}$	$G_{m+2,n+1}$	$DG_{m+3,n+1}$	$G_{m+4,n+1}$
$n+2$	$G_{m-3,n+2}$	$DG_{m-2,n+2}$	$G_{m-1,n+2}$	$DG_{m,n+2}$	$G_{m+1,n+2}$	$DG_{m+2,n+2}$	$G_{m+3,n+2}$	$DG_{m+4,n+2}$
$n+3$	$DG_{m-3,n+3}$	$G_{m-2,n+3}$	$DG_{m-1,n+3}$	$G_{m,n+3}$	$DG_{m+1,n+3}$	$G_{m+2,n+3}$	$DG_{m+3,n+3}$	$G_{m+4,n+3}$
$n+4$	$G_{m-3,n+4}$	$DG_{m-2,n+4}$	$G_{m-1,n+4}$	$DG_{m,n+4}$	$G_{m+1,n+4}$	$DG_{m+2,n+4}$	$G_{m+3,n+4}$	$DG_{m+4,n+4}$

도면14

	$m-3$	$m-2$	$m-1$	m	$m+1$	$m+2$	$m+3$	$m+4$
$n-3$	$DC_{m-3,n-3}$	$DC_{m-2,n-3}$	$DC_{m-1,n-3}$	$DC_{m,n-3}$	$DC_{m+1,n-3}$	$DC_{m+2,n-3}$	$DC_{m+3,n-3}$	$DC_{m+4,n-3}$
$n-2$	$G_{m-3,n-2}$	$DC_{m-2,n-2}$	$G_{m-1,n-2}$	$DC_{m,n-2}$	$G_{m+1,n-2}$	$DC_{m+2,n-2}$	$G_{m+3,n-2}$	$DC_{m+4,n-2}$
$n-1$	$DC_{m-3,n-1}$	$DC_{m-2,n-1}$	$DC_{m-1,n-1}$	$DC_{m,n-1}$	$DC_{m+1,n-1}$	$DC_{m+2,n-1}$	$DC_{m+3,n-1}$	$DC_{m+4,n-1}$
n	$G_{m-3,n}$	$DC_{m-2,n}$	$G_{m-1,n}$	$DC_{m,n}$	$G_{m+1,n}$	$DC_{m+2,n}$	$G_{m+3,n}$	$DC_{m+4,n}$
$n+1$	$DC_{m-3,n+1}$	$DC_{m-2,n+1}$	$DC_{m-1,n+1}$	$DC_{m,n+1}$	$DC_{m+1,n+1}$	$DC_{m+2,n+1}$	$DC_{m+3,n+1}$	$DC_{m+4,n+1}$
$n+2$	$G_{m-3,n+2}$	$DC_{m-2,n+2}$	$G_{m-1,n+2}$	$DC_{m,n+2}$	$G_{m+1,n+2}$	$DC_{m+2,n+2}$	$G_{m+3,n+2}$	$DC_{m+4,n+2}$
$n+3$	$DC_{m-3,n+3}$	$DC_{m-2,n+3}$	$DC_{m-1,n+3}$	$DC_{m,n+3}$	$DC_{m+1,n+3}$	$DC_{m+2,n+3}$	$DC_{m+3,n+3}$	$DC_{m+4,n+3}$
$n+4$	$G_{m-3,n+4}$	$DC_{m-2,n+4}$	$G_{m-1,n+4}$	$DC_{m,n+4}$	$G_{m+1,n+4}$	$DC_{m+2,n+4}$	$G_{m+3,n+4}$	$DC_{m+4,n+4}$

도면15

	$m-3$	$m-2$	$m-1$	m	$m+1$	$m+2$	$m+3$	$m+4$
$n-3$	$B_{m-3,n-3}$		$B_{m-1,n-3}$		$B_{m+1,n-3}$		$B_{m+3,n-3}$	
$n-2$								
$n-1$	$B_{m-3,n-1}$		$B_{m-1,n-1}$		$B_{m+1,n-1}$		$B_{m+3,n-1}$	
n								
$n+1$	$B_{m-3,n+1}$		$B_{m-1,n+1}$		$B_{m+1,n+1}$		$B_{m+3,n+1}$	
$n+2$								
$n+3$	$B_{m-3,n+3}$		$B_{m-1,n+3}$		$B_{m+1,n+3}$		$B_{m+3,n+3}$	
$n+4$								

도면16

	$m-3$	$m-2$	$m-1$	m	$m+1$	$m+2$	$m+3$	$m+4$
$n-3$	$B_{m-3,n-3}$	$DB_{m-2,m-3}$	$B_{m-1,n-3}$	$DB_{m,n-3}$	$B_{m+1,n-3}$	$DB_{m+2,n-3}$	$B_{m+3,n-3}$	$DB_{m+4,n-3}$
$n-2$	$DB_{m-3,n-2}$	$DB_{m-2,n-2}$	$DB_{m-1,n-2}$	$DB_{m,n-2}$	$DB_{m+1,n-2}$	$DB_{m+2,n-2}$	$DB_{m+3,n-2}$	$DB_{m+4,n-2}$
$n-1$	$B_{m-3,n-1}$	$DB_{m-2,n-1}$	$B_{m-1,n-1}$	$DB_{m,n-1}$	$B_{m+1,n-1}$	$DB_{m+2,n-1}$	$B_{m+3,n-1}$	$DB_{m+4,n-1}$
n	$DB_{m-3,n}$	$DB_{m-2,n}$	$DB_{m-1,n}$	$DB_{m,n}$	$DB_{m+1,n}$	$DB_{m+2,n}$	$DB_{m+3,n}$	$DB_{m+4,n}$
$n+1$	$B_{m-3,n+1}$	$DB_{m-2,n+1}$	$B_{m-1,n+1}$	$DB_{m,n+1}$	$B_{m+1,n+1}$	$DB_{m+2,n+1}$	$B_{m+3,n+1}$	$DB_{m+4,n+1}$
$n+2$	$DB_{m-3,n+2}$	$DB_{m-2,n+2}$	$DB_{m-1,n+2}$	$DB_{m,n+2}$	$DB_{m+1,n+2}$	$DB_{m+2,n+2}$	$DB_{m+3,n+2}$	$DB_{m+4,n+2}$
$n+3$	$B_{m-3,n+3}$	$DB_{m-2,n+3}$	$B_{m-1,n+3}$	$DB_{m,n+3}$	$B_{m+1,n+3}$	$DB_{m+2,n+3}$	$B_{m+3,n+3}$	$DB_{m+4,n+3}$
$n+4$	$DB_{m-3,n+4}$	$DB_{m-2,n+4}$	$DB_{m-1,n+4}$	$DB_{m,n+4}$	$DB_{m+1,n+4}$	$DB_{m+2,n+4}$	$DB_{m+3,n+4}$	$DB_{m+4,n+4}$

【심사관 직권보정사항】

【직권보정 1】

【보정항목】 청구범위

【보정세부항목】 청구항 40

【변경전】

상기 스토리지 디바이스 상에 저장되는

【변경후】

스토리지 디바이스 상에 저장되는

【직권보정 2】

【보정항목】 청구범위

【보정세부항목】 청구항 20

【변경전】

상기 방법은

【변경후】

하기 방법은



INTERNATIONAL APPLICATION PUBLISHED UNDER THE PATENT COOPERATION TREATY (PCT)

<p>(51) International Patent Classification ⁶ : H04N 5/228, 7/18</p>	<p>A1</p>	<p>(11) International Publication Number: WO 99/12345 (43) International Publication Date: 11 March 1999 (11.03.99)</p>
<p>(21) International Application Number: PCT/US98/15055 (22) International Filing Date: 21 July 1998 (21.07.98) (30) Priority Data: 08/921,486 2 September 1997 (02.09.97) US (71) Applicant (for all designated States except US): INTEL CORPORATION [US/US]; 2200 Mission College Boulevard, Santa Clara, CA 95052 (US). (72) Inventors; and (75) Inventors/Applicants (for US only): DELEEuw, William [US/US]; 239 N.E. 30th Avenue, Hillsboro, OR 97124 (US). WATSON, David [US/US]; 902 West Center Street, Spanish Fort, UT 84660 (US). KUKKAL, Puneet [IN/US]; 302 N.E. Phoenix Street, Hillsboro, OR 97124 (US). (74) Agents: TAYLOR, Edwin, H. et al.; Blakely, Sokoloff, Taylor & Zafman LLP, 7th floor, 12400 Wilshire Boulevard, Los Angeles, CA 90025 (US).</p>		<p>(81) Designated States: AL, AM, AT, AT (Utility model), AU (Petty patent), AZ, BA, BB, BG, BR, BY, CA, CH, CN, CU, CZ, CZ (Utility model), DE, DE (Utility model), DK, DK (Utility model), EE, EE (Utility model), ES, FI, FI (Utility model), GB, GE, GH, GM, HR, HU, ID, IL, IS, JP, KE, KG, KP, KR, KZ, LC, LK, LR, LS, LT, LU, LV, MD, MG, MK, MN, MW, MX, NO, NZ, PL, PT, RO, RU, SD, SE, SG, SI, SK, SK (Utility model), SL, TJ, TM, TR, TT, UA, UG, US, UZ, VN, YU, ZW, ARIPO patent (GH, GM, KE, LS, MW, SD, SZ, UG, ZW), Eurasian patent (AM, AZ, BY, KG, KZ, MD, RU, TJ, TM), European patent (AT, BE, CH, CY, DE, DK, ES, FI, FR, GB, GR, IE, IT, LU, MC, NL, PT, SE), OAPI patent (BF, BJ, CF, CG, CI, CM, GA, GN, GW, ML, MR, NE, SN, TD, TG).</p> <p>Published <i>With international search report.</i></p>

(54) Title: METHOD AND APPARATUS FOR TAKING DIGITAL PICTURES WITH AN INDUSTRY STANDARD FILM CAMERA

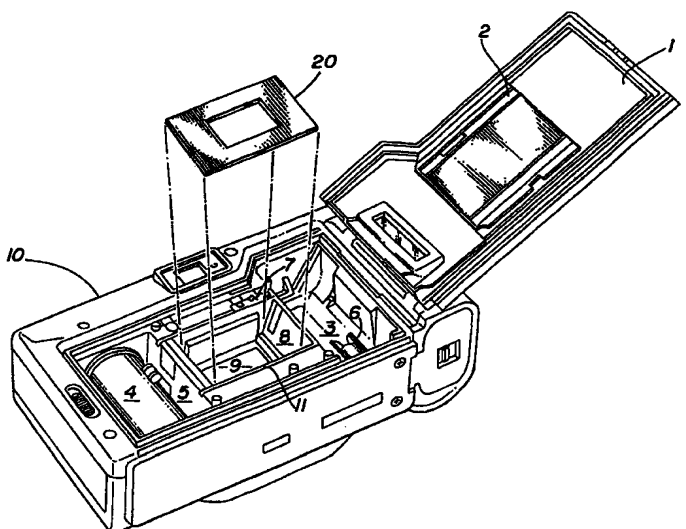

(57) Abstract

A method and apparatus for taking digital pictures. A film camera (10) having a standard back panel (1), a shutter (9), and a primary lens is provided. An image sensing array (35) is disposed within the camera in an area normally occupied by film so as to be in optical communication with the primary lens when the shutter is open. The read-out circuit is coupled to the image sensing array and reads out an image captured by the image sensing array (35). A memory (39) is coupled to a read-out circuit to store images read from the image sensing array, and the read-out circuit and the memory occupy a cavity vacated in the absence of film.

FOR THE PURPOSES OF INFORMATION ONLY

Codes used to identify States party to the PCT on the front pages of pamphlets publishing international applications under the PCT.

AL	Albania	ES	Spain	LS	Lesotho	SI	Slovenia
AM	Armenia	FI	Finland	LT	Lithuania	SK	Slovakia
AT	Austria	FR	France	LU	Luxembourg	SN	Senegal
AU	Australia	GA	Gabon	LV	Latvia	SZ	Swaziland
AZ	Azerbaijan	GB	United Kingdom	MC	Monaco	TD	Chad
BA	Bosnia and Herzegovina	GE	Georgia	MD	Republic of Moldova	TG	Togo
BB	Barbados	GH	Ghana	MG	Madagascar	TJ	Tajikistan
BE	Belgium	GN	Guinea	MK	The former Yugoslav Republic of Macedonia	TM	Turkmenistan
BF	Burkina Faso	GR	Greece	ML	Mali	TR	Turkey
BG	Bulgaria	HU	Hungary	MN	Mongolia	TT	Trinidad and Tobago
BJ	Benin	IE	Ireland	MR	Mauritania	UA	Ukraine
BR	Brazil	IL	Israel	MW	Malawi	UG	Uganda
BY	Belarus	IS	Iceland	MX	Mexico	US	United States of America
CA	Canada	IT	Italy	NE	Niger	UZ	Uzbekistan
CF	Central African Republic	JP	Japan	NL	Netherlands	VN	Viet Nam
CG	Congo	KE	Kenya	NO	Norway	YU	Yugoslavia
CH	Switzerland	KG	Kyrgyzstan	NZ	New Zealand	ZW	Zimbabwe
CI	Côte d'Ivoire	KP	Democratic People's Republic of Korea	PL	Poland		
CM	Cameroon	KR	Republic of Korea	PT	Portugal		
CN	China	KZ	Kazakstan	RO	Romania		
CU	Cuba	LC	Saint Lucia	RU	Russian Federation		
CZ	Czech Republic	LI	Liechtenstein	SD	Sudan		
DE	Germany	LK	Sri Lanka	SE	Sweden		
DK	Denmark	LR	Liberia	SG	Singapore		
EE	Estonia						

**METHOD AND APPARATUS FOR TAKING DIGITAL PICTURES
WITH AN INDUSTRY STANDARD FILM CAMERA**

BACKGROUND OF THE INVENTION

(1) **Field of the Invention**

The invention relates to digital photography. More specifically, the invention relates to providing an industry standard film camera the capacity to take digital pictures.

(2) **Related Art**

Film cameras have been around for decades. Among the typical cameras available are 35mm, 110, and 660. In the case of 35mm, a film canister is placed inside the cavity within the camera. The film leader is extended across an aperture which is in optical communication with a lens when a shutter is opened. The leader engages a take-up reel. The take-up reel is a core of a second cavity within the camera. As pictures are taken and the film advanced, the film is retained on the take-up reel. Some cameras initially advance all the film onto the take-up reel and then rewind frame by frame as pictures are taken. In either case, upon completion of the roll of film, the film is rewound off the take-up reel back within the canister. The canister must then be sent for processing before the pictures are available. Other varieties of cameras such as 110 and 660 are similar except they use a self-contained film cartridge with a built-in take-up reel. The whole cartridge is sent in for developing.

More recently, digital cameras have proliferated in the marketplace. A typical digital camera employs an electronic image sensing array, such as a charge coupled device (CCD) or CMOS image sensing array, which communicates with the lens of the camera. When a picture is taken, the shutter opens and exposes an image sensing array to light. The image sensing array thereby captures the image which is then retrieved from the array and stored in a memory. The camera can be coupled to a laptop computer or a desktop computer to download the images stored in memory. In that way, the picture is immediately available for on-screen viewing.

Some attempts have been made to provide film cameras with the ability to take digital pictures. These efforts have generally involved construction of a large relatively heavy replacement back panel for the camera which contains the necessary electronics required to take digital pictures. This does not facilitate the ready transition between film and digital pictures as the camera back must be interchanged depending on the medium in which the pictures are to be taken. Changing the camera back is difficult, time consuming and, in many cases, requires the service of a camera technician.

In view of the foregoing, it would be desirable to have a device which permits existing film cameras to take one or more digital pictures without excessive cost. It would also be desirable if the camera could be easily switched between taking digital pictures and taking film pictures by the user without requiring any service department assistance.

BRIEF SUMMARY OF THE INVENTION

A method and apparatus for taking digital pictures is disclosed. A film camera having a standard back panel, a shutter, and a primary lens is provided. An image sensing array is disposed within the camera in an area normally occupied by film so as to be in optical communication with the primary lens when the shutter is open. A read-out circuit is packaged to reside in a cavity normally occupied by film when the camera is employed to take standard pictures. The read-out circuit is coupled to the image sensing array and reads out an image captured by the image sensing array. A memory is coupled to a read-out circuit to store images read from the image sensing array. The memory is packaged to also reside in a cavity vacated in the absence of film. In one embodiment, the read-out circuit and the memory occupy the same cavity. In another embodiment, the read-out circuit and the memory occupy different cavities.

BRIEF DESCRIPTION OF THE DRAWINGS

Figure 1 is a perspective view of a camera for use with one embodiment of the invention.

Figure 2 is a back perspective view diagram of one embodiment of the invention.

Figure 3 is a top view of the memory housing of one embodiment of the invention.

Figures 4 - 6 is a block diagram of one embodiment of the invention.

Figure 7 is a top view of an alternative embodiment of the invention.

Figure 8 is a perspective rear view of the alternative embodiment of the invention of Figure 7.

Figure 9 is a top view of a second alternative embodiment of the invention.

Figure 10 is a cross-section view of one mechanical stop for use in the embodiment of Figure 8.

DETAILED DESCRIPTION OF THE INVENTION

Figure 1 shows a perspective view of a camera for use with one embodiment of the invention. The 35mm camera 10 has a standard back panel 1 with a spring-loaded pressure plate 2 coupled thereto. When used with conventional film, the film canister resides in cavity 3 and engages return post 6. The film is disposed over cavity 8 so that when shutter 9 is open, the film is in optical communication with a primary lens not shown on the other side of shutter 9. Drive gear 7 engages perforations in the edge of the film to advance the film on to take-up reel 4. As more pictures are taken, more and more film is advanced onto take-up reel 4 and fills more and more of cavity 5 which surrounds take-up reel 4. The pressure plate 2 holds the film against the edges 11 of cavity 8, thereby defining the frame size of each exposure. When used with the invention to take digital pictures, the requisite electronics and memory are disposed in one or both of film canister cavity 3 and take-up reel cavity 5, while the image sensing array resides over cavity 8. In one embodiment, a secondary lens 20 is inserted into cavity 8 to focus the light entering shutter 9 onto a smaller area. Secondary lens 20 may engage the sides of cavity 8 or may be coupled to the carrier for an image sensing array (ISA) as discussed further below. This permits a smaller ISA to be used and, therefore, reduces the cost of the array.

Figure 2 is a back perspective view diagram of one embodiment of the invention. A cylindrical image processing canister 30 shaped like a traditional film canister is provided to house image processing electronics discussed below in connection with Figures 4 - 7. Disposed on canister 30 is an image quality switch 32

which permits selection between resolution versus number of pictures which can be stored in the memory. The higher the resolution, the greater the memory required to store each picture. In some situations, a user may wish to give up some resolution in favor of more pictures before reloading. Switch 32 provides that capability. In one embodiment, it is a four-position switch. In another embodiment, one switch controls resolution, and a second switch controls color depth. A programmable film speed indicator 31 is disposed on the cylinder to be read like the film speed indicators on conventional film to indicate the speed at which the camera can operate with the ISA 35 that is being used. This permits different ISAs to be used with the same image processing canister 30. When installed, canister 30 is disposed over return post 6 (of Figure 1). Accordingly, canister 30 may be provided with a hollow area so as not to engage return post 6 such that the return post 6 is free to rotate unimpeded and without effecting the positioning of canister 30. Alternatively, canister 30 may engage return post 6 and be provided with a controlled friction wind mechanism to cause the camera to believe that the film has been successfully rewound or not as desired.

One problem faced in 35mm cameras which does not exist in 110 or 660 cameras is that the center-to-center distance 42 between the center of the film canister when installed and the take-up reel is variable. Both the distance 43 between the film canister and the aperture and the distance 44 between the aperture and the take-up reel are themselves variable. Thus, to accommodate variable distance 43, canister 30 has connector 33 coupled thereto. Connector 33 provides a relatively long connector surface for any incoming signal lines. Accordingly, if the variable distance is short, the signal lines can be inserted deeper into connector 33, and if the variable distance is long, the signal lines can be inserted less deeply into connector 33 while still insuring appropriate contact.

An ISA 35 is mounted so that the sensing surface may be disposed in optical communication with the camera lens when the shutter is open. ISA 35 can typically be mounted on a carrier such as a circuit board. Cameras typically accommodate at least 2 - 3 millimeters between pressure plate 2 (referring to Figure 1) and the top edge 11 of cavity 8 within the space that the ISD mounted on the circuit board will be disposed. Therefore, it is important that the thickness of the ISA/carrier combination not exceed 2 - 3mm if the combination is intended to be used in a broad spectrum of

existing cameras. Using existing techniques, it is possible to get an ISA/circuit board combination of two millimeters in thickness. Moreover, ISAs come in a range of sizes such that a single ISA may be used in one embodiment. In another embodiment, smaller edge buttable ISAs are used to produce a single ISA of larger size. In still another embodiment alluded to above and discussed below, a smaller ISA is used in conjunction with secondary lens 20 to provide a lower cost solution.

ISA 35 is coupled to the canister 30 at connector 33 by image access lines 34. Memory housing 39 having data port 40 is to be disposed in cavity 5 about take-up reel 4 (take-up reel 4, while shown in Figure 2, does not form a part of this invention). A film wind detector 41 engages take-up reel 4 and senses when a film advance has been initiated. Connector 37 is like connector 33, but will provide connection points for different signal lines. Significantly, this allows detachment and removal of the memory housing unit 39 from the ISA 35. Thus, memory units may be switched in and out, not unlike a regular roll of film. Memory access lines 36 couple canister 30 to memory housing 39. It is also anticipated that memory housing 39, in addition to housing the memory, will house a power supply which is a battery. In one embodiment, memory housing 39 is a half cylinder hollowed to accommodate the take-up reel 4.

In one embodiment, a tape backing 45 provides a backing for the image sense array 35 and the signal lines exiting therefrom. The tape backing 45 may be mylar or any other suitable material. The tape backing is prepared to engage connectors 33 and 37 so that tension is maintained and proper positioning of the image sensing array can be effected. Space 38 is provided in tape 45 to avoid interference with film drive gear 7.

Because of the variable distance issue discussed above, and the fact that the ISA is unlike regular 35mm film which has no pre-defined frames, steps must be taken to ensure that a user will properly position the ISA. To that end, it is desirable that there be some marking or gradation on the, e.g., tape backing to delineate by type of camera the depth of insertion appropriate. As one example, this may take the form of color bands and a package insert that advises the user which color band corresponds to which model of cameras.

Figure 3 is a top view of the memory housing 39 of one embodiment of the invention. The film wind detector 41 is shown engaging take-up reel 4 which are both shown in phantom lines. Connector 37 is shown engaging tape backing 45.

Figures 4 - 6 show a block diagram of one embodiment of the invention. A battery 100 provides power supply for the rest of the electronic components of the invention. A clock 101 is coupled to a clock division circuit 102. Clock 101 may be a suitable frequency crystal. The clock division circuit 102 converts the clock signal from the clock 101 into three clock signals, a bit clock 108, a pixel clock 107, and a scan clock 106. The frequency of the scan clock is determined by the time the clock must be asserted to read a scan line from the ISA 139. The pixel clock is the number of pixels in a scan line times faster than the scan clock, and the bit clock is at least the number of bits in a pixel line faster than the pixel clock. For example, assuming eight pixels in a scan line and eight bits in a pixel and that the scan clock has a frequency of one, the pixel clock and bit clock would have a frequency of eight and at least sixty-four, respectively. Switch 142 in this embodiment is a four-position quality select switch which generates two-bit quality select signal 103. Similarly, wind detection unit 143 generates a spool state signal 104.

A scan address counter 105 is responsive to scan clock 106 and addresses the ISA 139 along scan address lines 114. ISA 139 is responsive to pixel clock 107. Parallel pixel output 115 of the ISA 139 is fed into the capture start logic 110, along with the ISA pixel ready signal 111 and an addressing complete signal 134 generated by scan address counter 105. When the addressing complete signal 134 is asserted and the ISA pixel ready signal 115 is asserted, the capture start logic 110 determines from the parallel output 115 of the ISA 139 whether a picture has been taken. Effectively, the amount of light captured by the scan line indicates whether a picture has been taken, i.e., if the output light level exceeds a predetermined threshold, a picture has been taken. In one embodiment, an additional sensor is added to determine if the camera back is open. Opening the camera back would otherwise be interpreted as a picture taken because the ISA would exceed the light threshold. This sensor is particularly useful where it is desired to change the quality select setting "during the roll." For example, as the memory is filled up, a user may decide they want, e.g., three low resolution shots rather than a single additional high resolution

shot. If opening the camera back results in a "picture," memory would be wasted defeating the benefit of changing the quality settings.

If a picture has been taken, the capture start logic asserts a capture active signal 133 at both capture start gate 109 and the scan address counter. This enables the count of the scan address counter 105. When capture active is not asserted, the scan address counter 105 merely repeatedly asserts one predetermined scan address. Usually, the scan line is in the middle of the ISA. This scan line forms a basis for the capture start logic determination of a picture taken. The capture start gate 109 is responsive to both the ISA pixel ready signal 111 and the capture active signal 112. When both are asserted, capture start gate asserts pixel ready signal 113 to the input pixel compressor shown in **Figure 5**. In one embodiment, to improve power efficiency, the capture active signal 133 is used to disable all downstream units when it is deasserted.

While compression is not essential to the invention, because memory space is limited, compression will often be desirable. Input pixel compressor 117 is responsive to bit clock 108, a spool state signal 104, a quality select signal 103, and the pixel ready signal 111. The spool state signal 104 indicates the beginning of a new frame which should be tagged in memory to simplify downloading the frames from the memory at a later time. The quality select signals 103 contribute to the tag by defining the space that will be required to store the frame. The pixel ready signal 113 is used to signal the compressor 117 that a new image pixel is available on the parallel ISA pixel output signal lines 115. The compressor 117 also receives the parallel ISA pixel output signal lines 115. The input pixel compressor 117 compresses the parallel ISA pixel output as parallel compressor output 116, and it serves a compressed data ready signal 118 at input multiplexor 119. Input multiplexor 119 is also responsive to the bit clock 108 and serializes the parallel compressor output 116 as serial compressor output 121. It is important that the bit clock be sufficiently fast to permit the compressor to compress the incoming data on the parallel pixel output lines 115. The bit clock 108 should also be an integral multiple of the pixel clock 107. Input multiplexor 119 also asserts a bit ready signal 120. Both the bit ready signal 120 and the serial compressor output 121 are provided to the output decoder 122 which transforms the serial bit stream into parallel compressed data and asserts the storage data ready signal 124. The parallel

compressed data is transmitted on parallel compress storage data lines 123 to static memory 132 (shown in Figure 6).

A storage clock selection unit 128 senses connection to the data port 40 through the data port connects signal 125. When the data port 40 is connected, the external clock signal is provided as data port clock 126. The data storage clock selection unit 128 selects between the data port clock 126 and the data storage ready signal 124 to assert as the storage address clock 127. Storage address counter 130 addresses the memory 132 via memory address lines 131, and also generates an address ready signal 150. A read/write signal 129 is provided by the data port with a default to a write signal. The data port 40 receives the data stored in the memory along parallel output pixel storage data lines 136 and also asserts a data valid signal 137 to advise a downloading computer (not shown) whether the output data is valid.

Figure 7 is a top view of an alternative embodiment of the invention. In this embodiment, a single canister 200 has memory distributed around an outer cylinder 201. The memory may be, for example, flash memory. The hollow center core of the cylinder is constructed to accept a non-proprietary three-volt battery to power the memory and other required electronics. Connector 205 connects the carrier 204 which carries an image processing chip 203 and a JPEG compression chip 202. The image processing chip 203 retrieves captured images from image sensor array 206. Auto winds sprocket treadmill 207 is attached to the carrier 204 and engages winding gears and a camera to simulate film.

Figure 8 is a back perspective view of the alternative embodiment of the invention of Figure 7. In this figure, data port 210 is shown disposed on canister 200. A wind sensor 208 for detecting a rewind condition is also disposed on canister 200. Programmable speed indicators 211 are on the canister to be read by the camera in the conventional manner. A data port 210 is provided to allow easy downloading of images stored in the memory. Additionally, a liquid crystal display (LCD) 209 is disposed on the canister 200 so as to be readable through a window provided in many camera back panels. The LCD 209 may, e.g., display the number of shots remaining at the current resolution level. The treadmill 207 is also shown. The treadmill 207 advances similar to regular film so that the camera believes it has advanced regular film. There are a number of ways an "end of roll" condition can be handled. In one embodiment, operation of the treadmill 207 is constant as between

any two pictures. In this embodiment, the user must recognize by, e.g., the LCD 209 display that a maximum number of shots has been taken. Other signaling mechanisms such as an audible tone may be used to indicate the memory is full. The user must then take steps to empty the memory. It is desirable to ensure that the memory will not overwrite itself if the number of pictures taken exceeds the capacity of the memory.

In an alternative embodiment, a mechanical stop mechanism prevents advancement of the treadmill 207 after a last shot is taken. Figure 10 is a cross-sectional view of one such mechanical stop. When a last picture is taken, pin 220 is triggered to engage sprockets 222 of a treadmill axle 221. Pin 210 engages the sprockets 222 so as to prevent advancement, but permits auto rewind to occur unhampered. Once auto rewind begins, pin 10 is reset to a disengaged position. Other ways of increasing treadmill tension to simulate the "end of roll" condition will occur to those of ordinary skill in the art and are within the scope and contemplation of the invention.

Figure 9 is a top view of a second alternative embodiment of the invention. This embodiment is similar in most respects to the embodiment of Figure 7. However, the secondary lens 220 extends from carrier 204 to focus light entering the camera onto ISA 219 which has a smaller area than a typical film frame. Secondary lens 220 should be affixed to carrier 204 to ensure that the appropriate focal length between the secondary lens 220 and the ISA 219 is maintained. This embodiment will only be suitable for cameras in which the shutter is set significantly forward of the film plane such as the camera shown in Figure 1. It is expected that the smaller ISA 219 will significantly reduce the cost of the overall apparatus.

In the foregoing specification, the invention has been described with reference to specific embodiments thereof. It will, however, be evident that various modifications and changes can be made thereto without departing from the broader spirit and scope of the invention as set forth in the appended claims. The specification and drawings are, accordingly, to be regarded in an illustrative rather than a restrictive sense. Therefore, the scope of the invention should be limited only by the appended claims.

CLAIMS

What is claimed is:

1. An apparatus for converting a film camera to a digital camera, the apparatus comprising:
 - an image sensing array;
 - a read-out circuit coupled to the image sensing array; and
 - a memory coupled to the read-out circuit, the memory for storing an image read-out from the image sensing array;wherein the memory and the read-out circuit are packaged to be retained in a space vacated in the absence of film in the camera and wherein the apparatus is easily installable in the film camera so that the image sensing array is in optical communication with a lens when a shutter of the film camera is open.
2. The apparatus of claim 1 further comprising:
 - a resolution selector coupled to the read-out circuit which allows a user to select one of a plurality of resolutions for a digital picture derived from the image captured.
3. The apparatus of claim 1 further comprising:
 - a sensor coupled to the readout circuit, the sensor for detecting when the camera back is open.
4. The apparatus of claim 1 further comprising:
 - a sensor for detecting a film advance condition.
5. The apparatus of claim 1 further comprising:
 - a power supply coupled to the memory and a data port coupled to the memory for retrieving images stored in the memory.
6. The apparatus of claim 5 wherein the memory, the data port, and power supply for a cartridge, the cartridge being detachable from the readout circuit and image sensing array such that cartridges can be switched in and out.
7. An apparatus comprising:
 - a film camera having a back panel and a lens;

an image sensing array disposed within the back panel so as to be in optical communication with the lens of the camera when a shutter of the camera is open;

a read-out circuit coupled to the image sensing array and reading an image captured responsive to a signal; and

a memory coupled to the read-out circuit which stores the image read-out by the read-out circuit responsive to the signal;

wherein both the memory and the read-out circuit are disposed in cavities vacated in an absence of film.

8. The apparatus of claim 7 further comprising:

a resolution selector coupled to the read-out circuit which allows a user to select one of a plurality of resolutions for a digital picture derived from the image captured.

9. The apparatus of claim 7 wherein the image sensing array is smaller in area than a frame of conventional film for the camera and further comprising:

a secondary lens, the secondary lens focusing light entering the shutter on to an area approximately a size of the image sensing array.

10. The apparatus of claim 7 further comprising:

a sensor coupled to the readout circuit, the sensor for detecting when the camera back is open.

11. The apparatus of claim 7 further comprising:

a sensor for detecting a film advance condition.

12. The apparatus of claim 7 further comprising:

a power supply coupled to the memory and a data port coupled to the memory for retrieving images stored in the memory.

13. The apparatus of claim 12 wherein the memory, the data port, and power supply for a cartridge, the cartridge being detachable from the readout circuit and image sensing array such that cartridges can be switched in and out.

14. The apparatus of claim 7 wherein the camera is one of 35mm, 110, and 660.

15. A method of taking a digital picture with a film camera comprising the steps of:

loading an image sensing array to be in optical communication with a lens of the camera when a shutter is open;

inserting a read-out circuit and a memory unit into at least one cavity in the camera;

exposing the image sensing array by opening the shutter;

reading the image array to acquire image data; and

storing the image data in the memory unit.

16. The method of claim 15 further comprising the step of:

polling the image sensing array to determine if it has been exposed.

17. The method of claim 15 wherein the polling step comprises the steps of:

reading a line of the image sensing array; and

comparing a light level at the line with a threshold level indicating a picture has been taken.

18. The method of claim 15 further comprising the step of:

inserting a secondary lens between the shutter and the image sensing array, wherein the image sensing array is smaller in area than film used in the camera and wherein the secondary lens focuses light entering through the shutter on the smaller area.

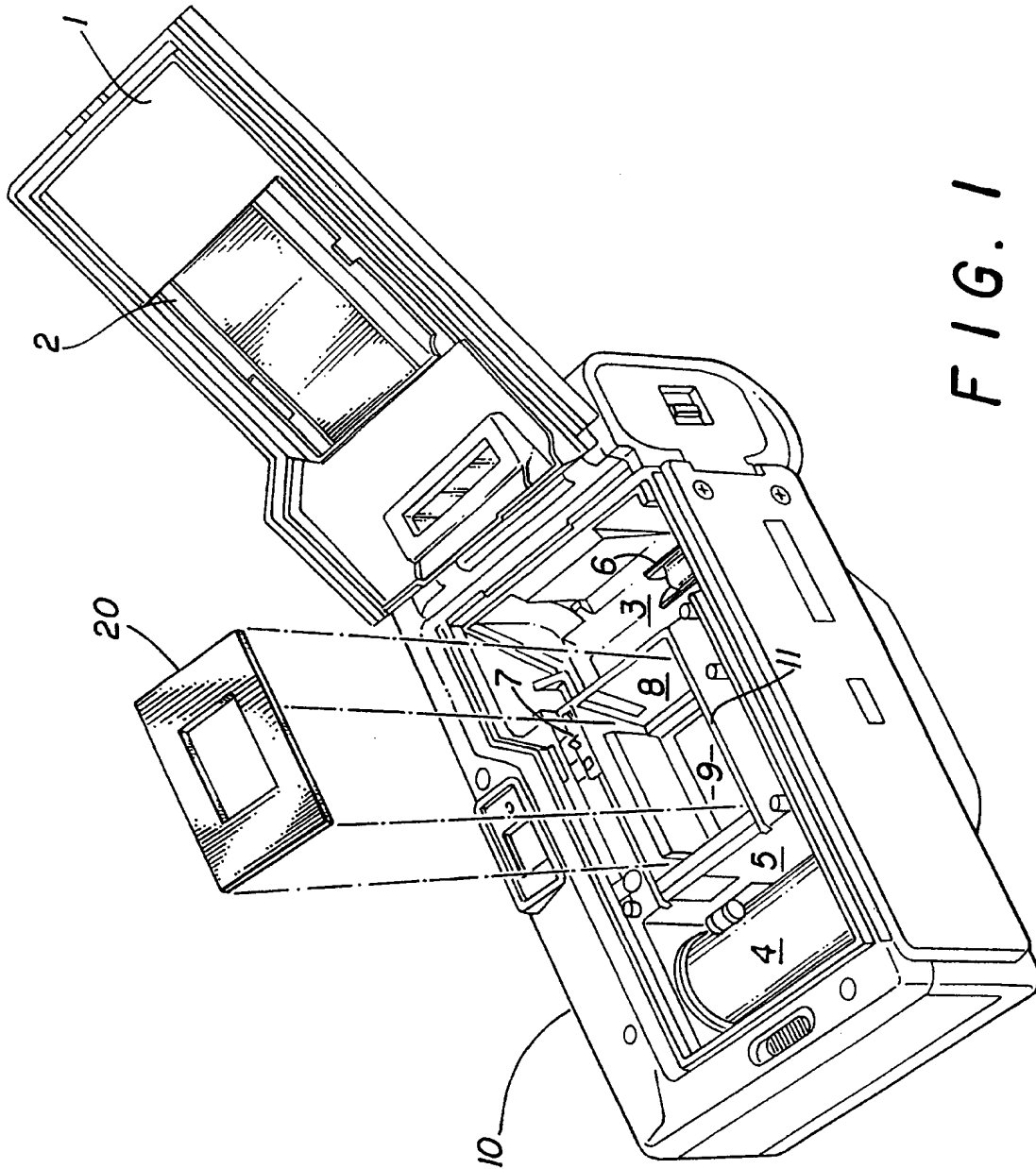

FIG. 1

SUBSTITUTE SHEET (RULE 26)

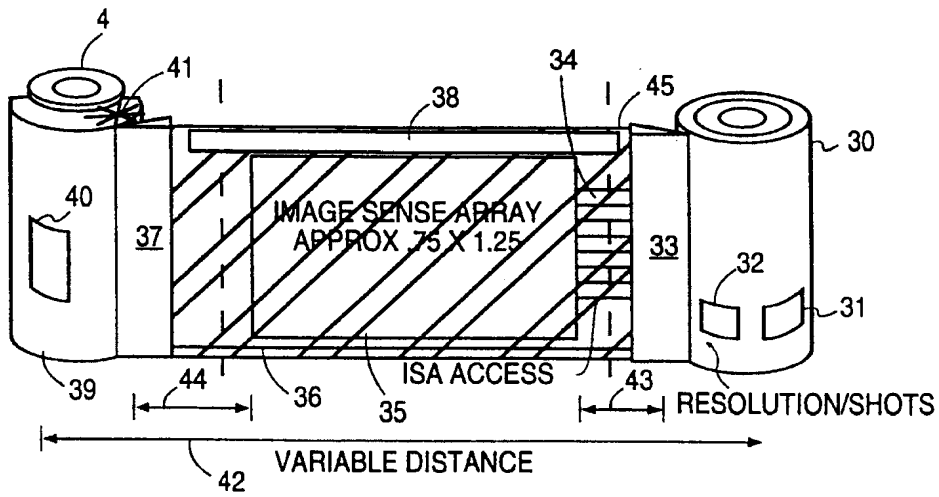

FIG. 2

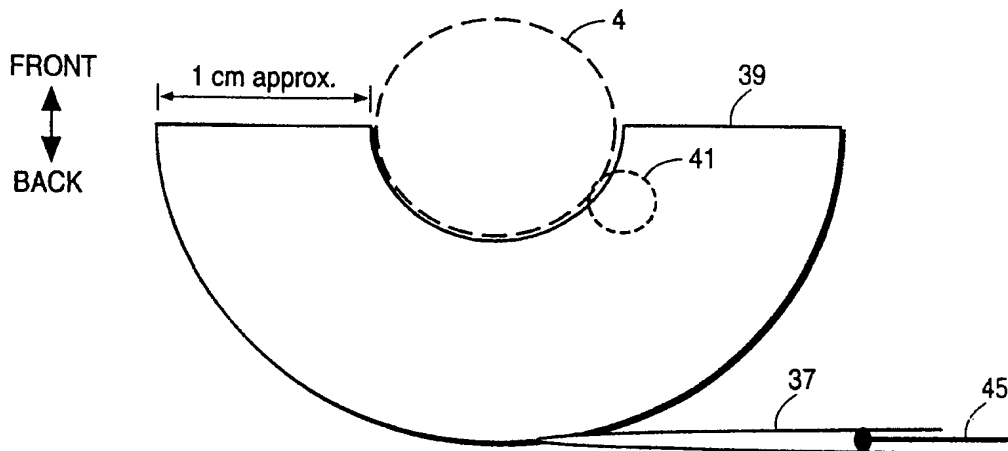

FIG. 3

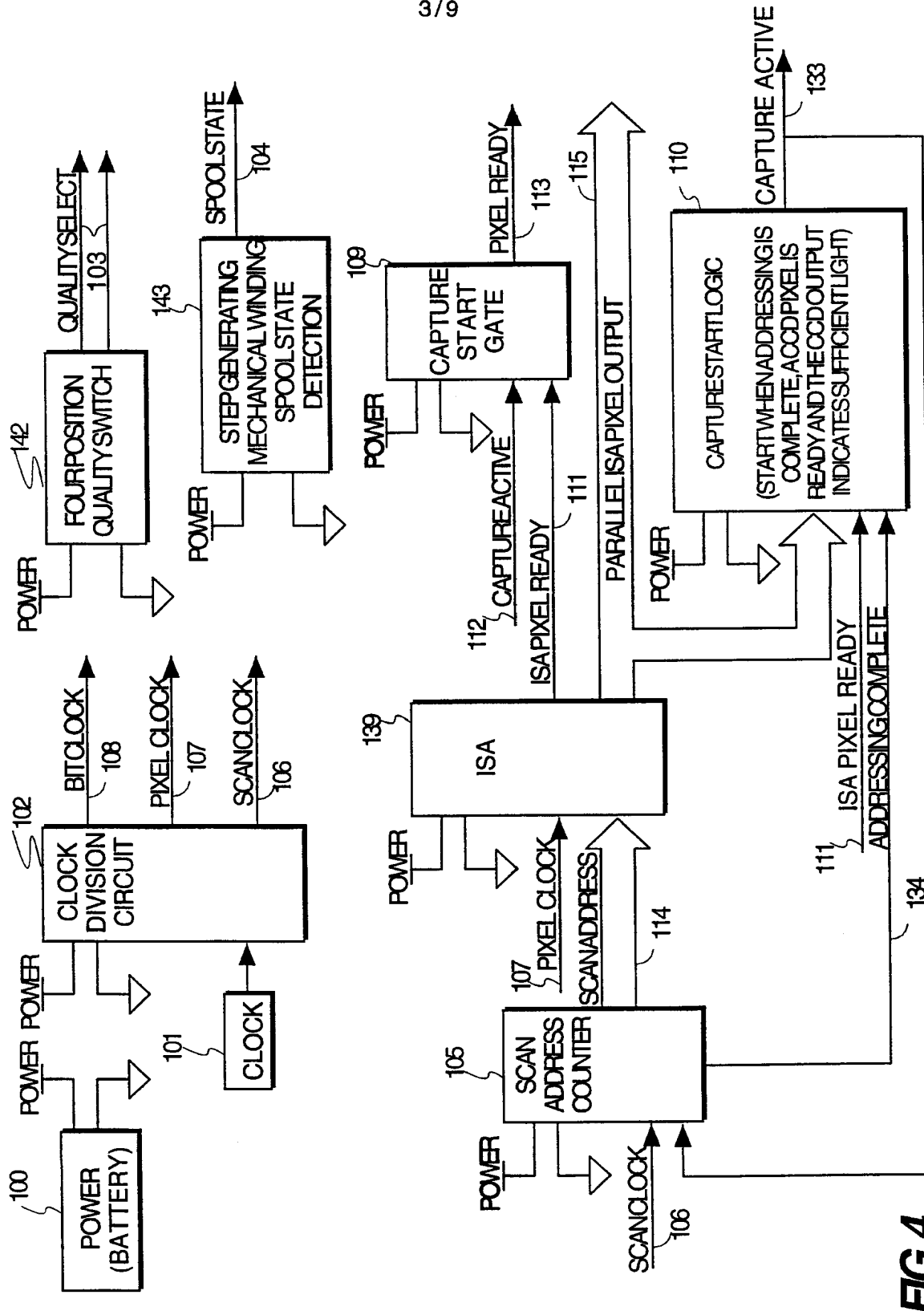

FIG. 4

SUBSTITUTE SHEET (RULE 26)

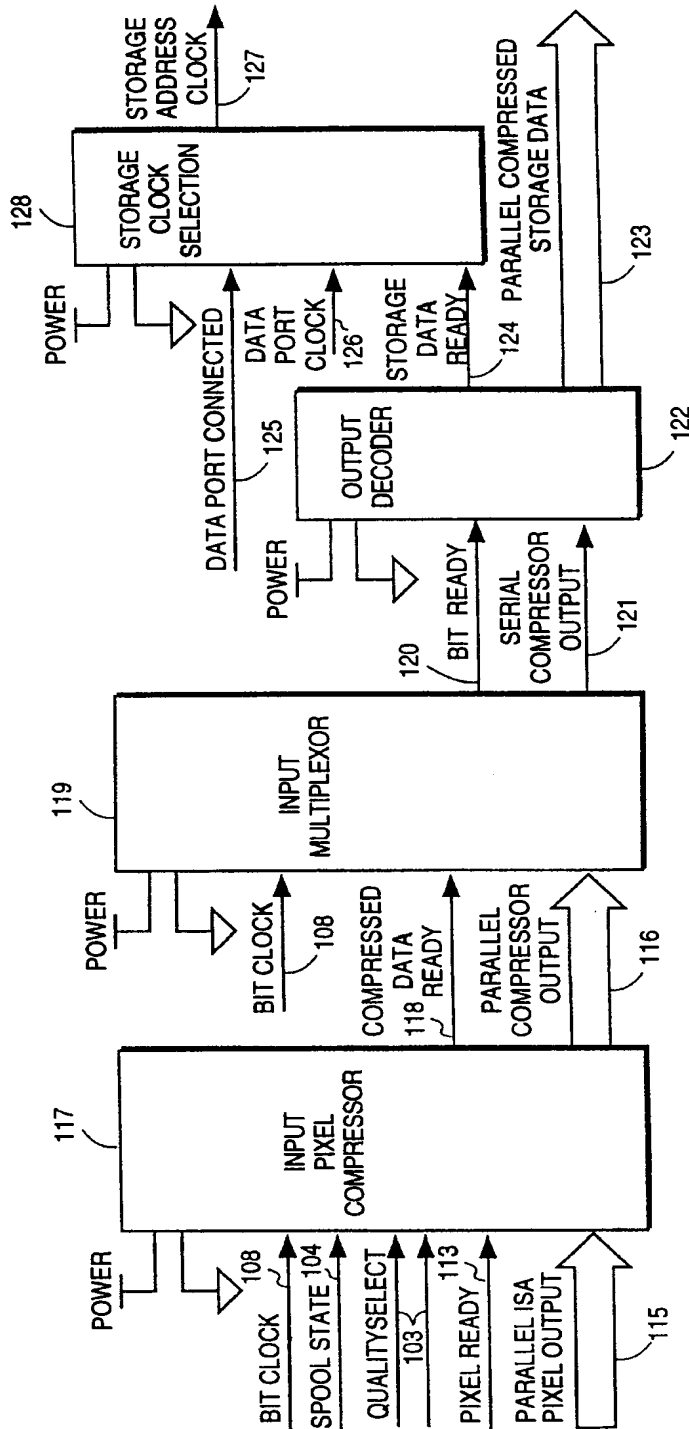

FIG. 5

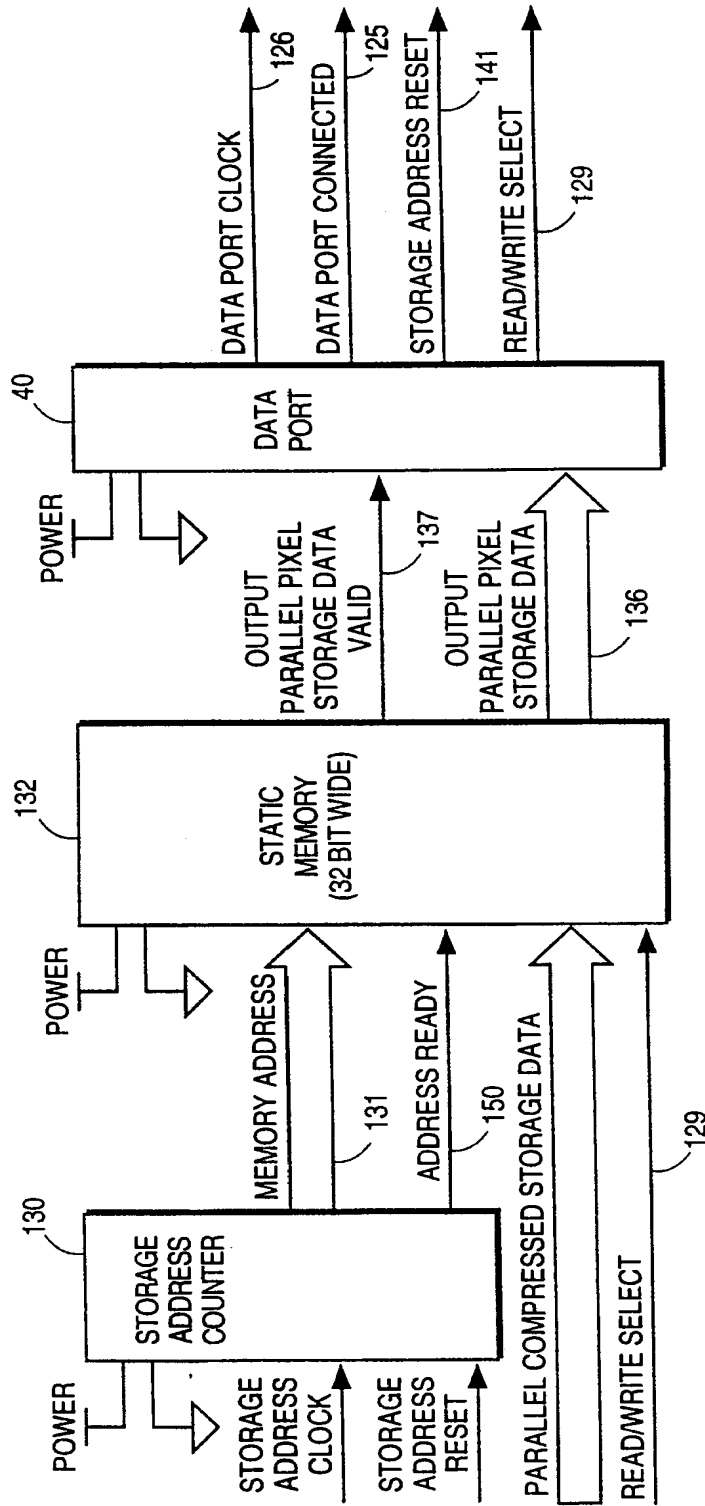

FIG. 6

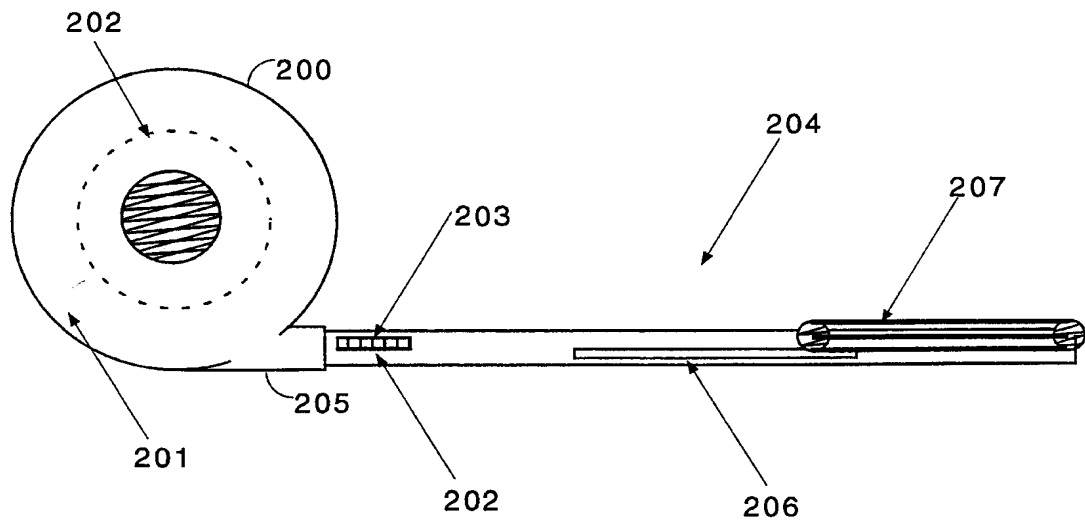

Fig. 7

SUBSTITUTE SHEET (RULE 26)

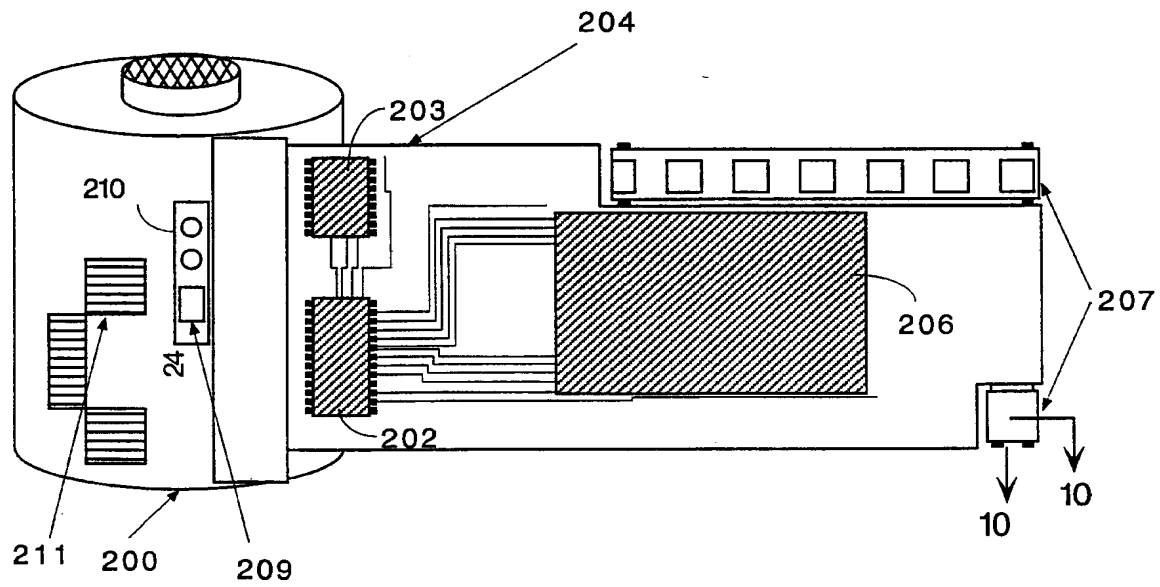

Fig. 8

SUBSTITUTE SHEET (RULE 26)

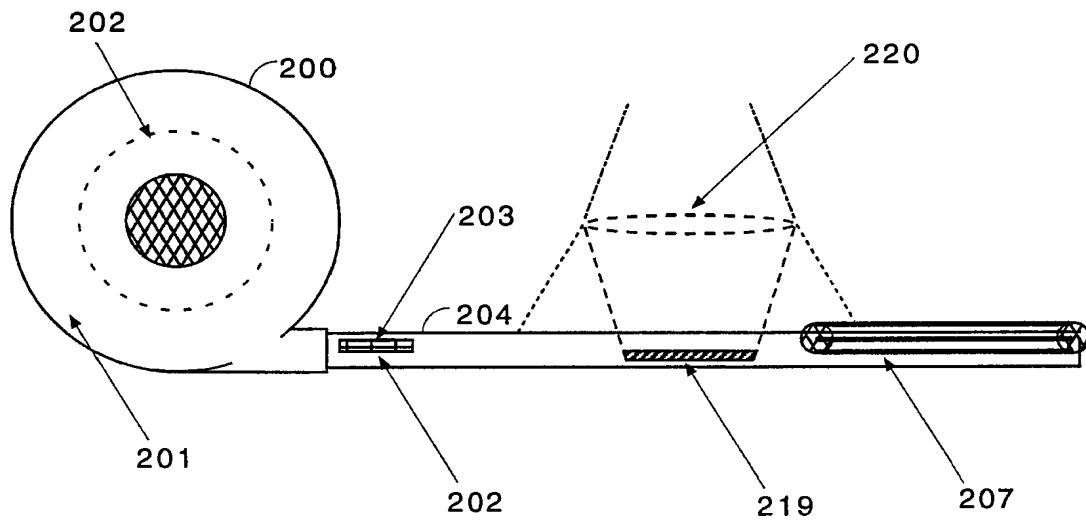

Fig. 9

SUBSTITUTE SHEET (RULE 26)

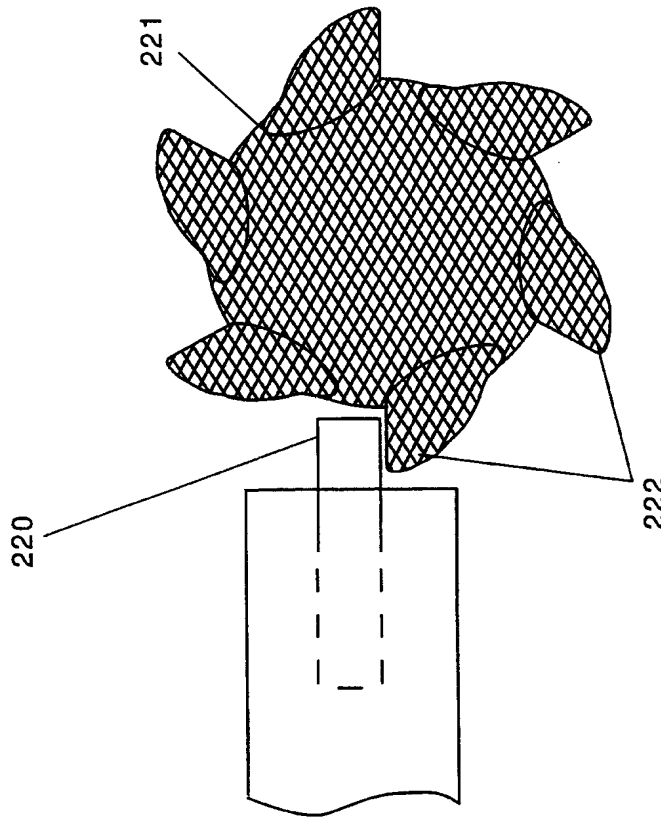
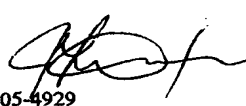

Fig. 10

SUBSTITUTE SHEET (RULE 26)

INTERNATIONAL SEARCH REPORT

International application No.
PCT/US98/15055

A. CLASSIFICATION OF SUBJECT MATTER		
IPC(6) :HO4N 5/228, 7/18 US CL : 348/222, 64 According to International Patent Classification (IPC) or to both national classification and IPC		
B. FIELDS SEARCHED		
Minimum documentation searched (classification system followed by classification symbols) U.S. : 348/222, 64, 231, 232, 233, 96, 372, 373, 374, 375; 396/429; 358/909.1		
Documentation searched other than minimum documentation to the extent that such documents are included in the fields searched		
Electronic data base consulted during the international search (name of data base and, where practicable, search terms used)		
C. DOCUMENTS CONSIDERED TO BE RELEVANT		
Category*	Citation of document, with indication, where appropriate, of the relevant passages	Relevant to claim No.
X --- Y	US 5,561,458 A (CRONIN et al) 01 October 1996, Figs. 1-9, col. 5-7, lines 1-68, col. 11, lines 1-68.	1-18 --- 3-4, 10-11
Y	US 4,814,811 A (SAITO et al) 21 March 1989, Figs. 4 & 10, col. 4, line 1 to col. 5, line 68.	3-4, 10-11
<input type="checkbox"/> Further documents are listed in the continuation of Box C. <input type="checkbox"/> See patent family annex.		
* "A" "E" "L" "O" "P"	Special categories of cited documents: document defining the general state of the art which is not considered to be of particular relevance earlier document published on or after the international filing date document which may throw doubts on priority claim(s) or which is cited to establish the publication date of another citation or other special reason (as specified) document referring to an oral disclosure, use, exhibition or other means document published prior to the international filing date but later than the priority date claimed	"T" "X" "Y" "&" later document published after the international filing date or priority date and not in conflict with the application but cited to understand the principle or theory underlying the invention document of particular relevance; the claimed invention cannot be considered novel or cannot be considered to involve an inventive step when the document is taken alone document of particular relevance; the claimed invention cannot be considered to involve an inventive step when the document is combined with one or more other such documents, such combination being obvious to a person skilled in the art document member of the same patent family
Date of the actual completion of the international search 23 SEPTEMBER 1998		Date of mailing of the international search report 15 OCT 1998
Name and mailing address of the ISA/US Commissioner of Patents and Trademarks Box PCT Washington, D.C. 20231 Facsimile No. (703) 305-3230		Authorized officer WENDY GARBER  Telephone No. 703-305-4929

Form PCT/ISA/210 (second sheet)(July 1992)*

(19) 日本国特許庁 (J P)

(12) 公表特許公報 (A)

(11) 特許出願公表番号
特表2001-515318
(P2001-515318A)

(43) 公表日 平成13年9月18日 (2001.9.18)

(51) Int.Cl. ⁷	識別記号	F I	テームコード* (参考)
H 0 4 N 5/225		H 0 4 N 5/225	D
	5/232	5/232	F
// H 0 4 N 101:00		101:00	Z

審査請求 未請求 予備審査請求 有 (全 24 頁)

(21) 出願番号 特願2000-509219(P2000-509219)
 (86) (22) 出願日 平成10年7月21日(1998.7.21)
 (85) 翻訳文提出日 平成12年3月2日(2000.3.2)
 (86) 国際出願番号 PCT/US 98/15055
 (87) 国際公開番号 WO 99/12345
 (87) 国際公開日 平成11年3月11日(1999.3.11)
 (31) 優先権主張番号 08/921, 486
 (32) 優先日 平成9年9月2日(1997.9.2)
 (33) 優先権主張国 米国 (US)

(71) 出願人 インテル・コーポレーション
 アメリカ合衆国 95052 カリフォルニア
 州・サンタクララ・ミッション カレッジ
 ブレーバード・2200
 (72) 発明者 デレュー, ウィリアム
 アメリカ合衆国・97124・オレゴン州・ヒ
 ルズボロ・ノース イースト 30ティエイ
 チ アベニュー・239
 (72) 発明者 ワトソン, デイビッド
 アメリカ合衆国・84660・ユタ州・スバニ
 ッシュ フォート・ウエスト センター
 ストリート・902
 (74) 代理人 弁理士 山川 政樹

最終頁に続く

(54) 【発明の名称】 業界標準のフィルム・カメラを用いてデジタル写真を撮影する方法および機器

(57) 【要約】

デジタル写真を撮影する方法および機器。標準後部パネル (1)、シャッター (9)、および主レンズを有するフィルム・カメラ (10) が提供される。画像感知アレイ (35) は、カメラ内の普通であればフィルムが占有している領域に配置されて、それにより、シャッターが開いたときに主レンズと光学的連絡をするようになっている。読取り回路は、画像感知アレイに結合されて、画像感知アレイ (35) によって取り込まれた画像を読み取る。メモリ (39) は、読取り回路に結合されて、画像感知アレイから読み取った画像を記憶し、読取り回路とメモリは、フィルムが存在しないために空いている空洞を占める。

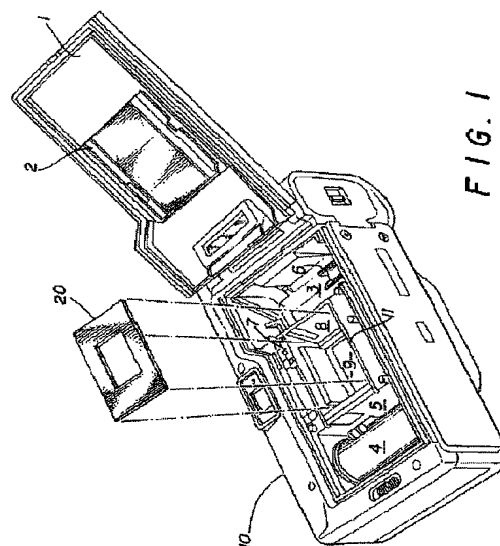

【特許請求の範囲】

【請求項1】 画像感知アレイと、
画像感知アレイに結合された読取り回路と、
読取り回路に結合され、画像感知アレイから読み取った画像を記憶するメモリとを備え、

前記メモリと前記読取り回路が、フィルムが存在しないために空いているカメラ内の空間に保持されるように実装される、フィルム・カメラをデジタル・カメラに変換する機器であって、

フィルム・カメラのシャッターが開いているときに画像感知アレイがレンズと光学的に連絡されるように、フィルム・カメラ内に容易に据え付け可能な機器。

【請求項2】 読取り回路に結合され、取り込まれた画像から得られるデジタル写真に対して複数の解像度の1つをユーザに選択させる解像度選択装置をさらに備える請求項1に記載の機器。

【請求項3】 読取り回路に結合され、カメラ後部が開いている時を検出するセンサをさらに備える請求項1に記載の機器。

【請求項4】 フィルム送り状態を検出するセンサをさらに備える請求項1に記載の機器。

【請求項5】 メモリに結合された電源と、メモリに結合され、メモリに記憶された画像を引き出すデータ・ポートとをさらに備える請求項1に記載の機器。

【請求項6】 前記メモリ、データ・ポート、および電源がカートリッジとされ、そのカートリッジが、交換できるように、読取り回路および画像感知アレイから取り外し可能になっている請求項5に記載の機器。

【請求項7】 後部パネルおよびレンズを有するフィルム・カメラと、
後部パネル内に配置され、それにより、カメラのシャッターが開いているときにカメラのレンズと光学的に連絡される画像感知アレイと、
画像感知アレイに結合され、信号に応答して取り込まれた画像を読み取る読取り回路と、

読取り回路に結合され、前記信号に応答して読取り回路によって読み取られた

Bibliographic data: CN101689357 (A) — 2010-03-31

Video camera

Inventor(s): JAMES JANNARD; GRAEME NATTRESS THOMAS ± (JANNARD JAMES, ; NATTRESS THOMAS GRAEME)

Applicant(s): RED COM INC ± (RED COM INC)

Classification: - **international:** G09G5/02
- **cooperative:** G06T3/4015; G11B27/031; H04N1/648; H04N19/186; H04N19/85; H04N19/91; H04N5/2252; H04N5/374; H04N5/772; H04N9/045

Application number: CN2008818570 20080411

Priority number(s): WO2008US60126 20080411 ; US20070911196P 20070411 ; US20070017406P 20071228

Also published as: CN101689357 (B) WO2008128112 (A1) US2015002695 (A1) US2015003801 (A1) US2012301102 (A1) more

Abstract of CN101689357 (A)

A video camera can be configured to highly compress video data in a visually lossless manner. The camera can be configured to transform blue and red image data in a manner that enhances the compressibility of the data. The data can then be compressed and stored in this form. This allows a user to reconstruct the red and blue data to obtain the original raw data for a modified version of the original raw data that is visually lossless when demosaiced. Additionally, the data can be processed in a manner in which the green image elements are demosaiced first and then the red and blue elements are reconstructed based on values of the demosaiced green image elements.

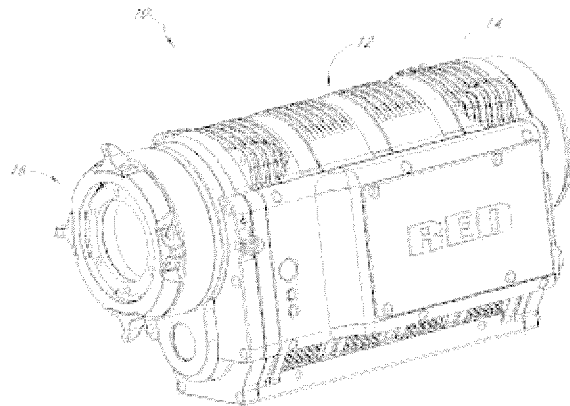

FIG. 2

DESCRIPTION

[0001]

TECHNICAL FIELD

[0002]

The present invention relates to a digital camera, for example, for capturing digital still or moving images Camera, and more particularly, it relates to a compressed image data a digital camera.

[0003]

Background

[0004]

Although there are digital cameras available, but most of the moving image and the number of television broadcast media

Producers still rely film camera body.

As used herein the film to the video editor

High resolution images can be edited using traditional methods.

However, recently, such films often

It is scanned, digitized, and digital editing.

[0005]

DISCLOSURE

[0006]

Although some currently available digital video cameras include high resolution image sensor, so that High-resolution video output; however, the image processing is widely used in these cameras and the press Loss reduction technique too, thus eliminating much of the original image data can not be high above the city Field acceptance.

An aspect disclosed herein include at least one embodiment of implementation: may be on

Said the high-end market (for example, most of the moving picture market) acceptable video quality can be so

Camera meet, which can capture and store at least about 2k resolution, and at least about 23 per

Second frame rate of the original or substantially original video data.

[0007]

Thus, according to one embodiment, a video camera can comprise a portable housing, and by

The housing and configured to support a condenser lens assembly.

Photosensitive device can be configured to at least about 23

Frame rate of frames per second will focus light into at least 2k resolution of the original image data.

The camera may further include a memory device and an image processing system, image processing system is configured to

At least about 23 per second frame rate and compression ratio of at least 6 to 1 and remains substantially visually lossless

Compress and store raw image data to the storage device.

[0008]

According to another embodiment, the active video camera recording method may include the light guide

The photosensitive devices.

Notice

This translation is machine-generated. It cannot be guaranteed that it is intelligible, accurate, complete, reliable or fit for specific purposes. Critical decisions, such as commercially relevant or financial decisions, should not be based on machine-translation output.

The method may further comprise converting light received by the photosensitive device having at least Original digital image data is greater than 23 per second frame rate, compression of the original digital image data, And the original image data having a frame rate of at least about 23 per second recorded in the memory device.

[0009]

According to yet another embodiment, a video camera can comprise a through housing and configured to support And condenser lens assembly configured to focus the light into the focusing of the original image represented by light Image data signal sensitive device.

The camera can also include memory devices, and for compressing and The apparatus has at least about 23 per second frame rate of the original image data is recorded.

[0010]

According to a further embodiment, a video camera may comprise at least one handle having it Carrying case, which is configured to allow a user of the camera during the video recording operation, the operation On the housing at least one degree of freedom of orientation activities.

The lens assembly may comprise a housing through And configured to support a condenser disposed within the housing on a plane at least one lens. Photosensitive

The device can be configured to focus light into at least 2k horizontal resolution and at least about 23 Frames per second frame rate of the original image data.

Memory device may also be configured to store video image data.

The image processing system can be configured to at least about 23 frames per second frame rate and compression ratio of at least 6 to 1

Compress and store raw image data to the storage device, but remain substantially visually lossless.

[0011]

Disclosed herein at least one embodiment of the hand including the realization: because the human eye to green Color wavelength is more sensitive than any other color, so the image data output from the image sensor

The compressibility of the green image data based modification can be used to increase the data, it also provides higher

Quality video images.

One such technique may be included in the compressed data from the probe prior to the red

Minus the detected magnitude value of color and / or blue light, green light.

This may be the red and /

Or blue image data into a more compressible format.

For example, in the gamma corrected

RGB data into Y'CbCr known method, the image "decorrelation", mostly remaining

The number of image data Y '(also known as "brightness"), so that the remaining more compressed chrominance component

Sex.

However, for conversion to Y'CbCr known techniques can not be applied directly Bayer pattern

Data, since each color data is spatially uncorrelated, Bayer pattern data includes twice as much blue

Red or green image data of the image data.

According to some embodiments disclosed herein,

Minus the green image data method, similar to the above Y'CbCr converted because most Figure

Image data remain green image data, so that the remaining data become more compression format.

[0012]

Further, the process can be subtracted rebellious green image data, to preserve all the original Data.

Thus, a combination of systems and methods of this technique can provide lossless or generated depending Sleep lossless and compressibility improved video image data.

[0013]

Thus, according to one embodiment, a video camera can comprise a support and distribution through the housing

Notice

This translation is machine-generated. It cannot be guaranteed that it is intelligible, accurate, complete, reliable or fit for specific purposes. Critical decisions, such as commercially relevant or financial decisions, should not be based on machine-translation output.

Set and condenser lens assembly configured to convert the focused light representing the focused light to
At least the first, second and third color photosensitive device image data of the original signal.
Image Department
Management module can be configured based on the third color image data to modify the first and second color to
At least one of the image data.
Additionally, the camera can include memory devices and configured to compress the first
First, second, and third color image data and the compressed image data stored in the memory element
The compression device.

[0014]

According to another embodiment, there is provided a method of processing an image.
The method may pack
Comprising: converting an image represented by the first color of the first image data representing a second color first
Second, third color image data representing a third image data; third image data based repair
Change at least a first image data and second image data; compressed image data and the first modification of the
third
And storing the compressed data; and second image data.

[0015]

According to yet another embodiment, a video camera can comprise a through housing and configured to support
The condenser lens assembly.
Photosensitive device may be configured to focus light into the focus of the representative
At least first, second and third color image data of the original signal light.
The camera also
May include: a third color image data is based on modifying the first and second color in at least one
Means of image data; storage devices; and configured to compress the first, second and third color
The image data and stores the compressed image data compression device to the memory device.

[0016]

Brief Description

[0017]

Figure 1 shows, according to one embodiment may include hardware and / or can be configured to perform
A system block diagram of a method for processing the video image data;

[0018]

Figure 2 is an alternative embodiment of FIG. 1 schematically illustrates the way the camera housing;

[0019]

3 image transfer is used in the system shown in Figure 1 has a Bayer pattern filter
Sensor schematic distribution;

[0020]

Figure 4 is a schematic block diagram of the system shown in Figure 1 of the image processing module;

[0021]

Figure 5 is a green image data from the image sensor in FIG. 3 of the green sensor unit
Schematically distribution;

Notice

This translation is machine-generated. It cannot be guaranteed that it is intelligible, accurate, complete, reliable or fit for specific purposes. Critical decisions, such as commercially relevant or financial decisions, should not be based on machine-translation output.

[0022]

Figure 6 is an optional process after removing some of the original green image data after left in Figure 5 Schematically distributed green image data;

[0023]

Figure 7 is a tissue of processing in the image processing module of FIG. 1 in FIG. 5 red, blue And exemplary green image data distribution;

[0024]

FIG 8 is a diagram showing the image data may be used in the system shown in Figure 1 a flow conversion technology Figure;

[0025]

8A is a diagram showing the image data may also be used in the system shown in Figure 1 conversion technologies Flowchart modified;

[0026]

Figure 9 is an image produced in the transformation process in FIG. 8 a schematic distribution of the blue image data;

[0027]

FIG 10 is generated in FIG. 8 image conversion process schematic red image data points Cloth;

[0028]

Figure 11 shows the image data may be applied to gamma correction exemplary optional transform;

[0029]

FIG. 12 is a diagram of the system in order to decompress the image data and demosaiced Program control flow graph;

[0030]

12A is a diagram showing the system can also be used as shown in FIG. 1, the control program 12 in FIG. Modified flow chart;

[0031]

Figure 13 is a compression and mosaics have been illustrated in FIG. 12 according to the flow of the green image data Schematic distribution;

[0032]

Figure 14 is a compression and mosaics have been illustrated in FIG. 12 in the process according to the original green 13 Half of the schematic distribution of the color image data;

Notice

This translation is machine-generated. It cannot be guaranteed that it is intelligible, accurate, complete, reliable or fit for specific purposes. Critical decisions, such as commercially relevant or financial decisions, should not be based on machine-translation output.

[0033]

15 is already in the process illustrated in FIG. 12 according to the blue image data compression schematic points Cloth; and

[0034]

Figure 16 is a flow chart has been based on demosaicized Figure 12 15 blue image data Schematically distribution.

[0035]

DETAILED DESCRIPTION

[0036]

Figure 1 is an image sensing, processing, and schematic diagram of the camera's compression module, described as For the case of a moving image of the camera.

Embodiments disclosed herein describe this situation:

Camera with a single sensor device with Bayer pattern filter, because these embodiments

In this case the formula is particularly advantageous.

However, the embodiments and the invention can also be applied here

It has other types of image sensors (e.g., CMY Bayer as well as other non-Bayer mold

Type) camera, the camera having other numbers of image sensors, the image in a different format type

Camera-type operation, and configured for the camera still and / or moving images.

Accordingly, it should be

We understood that the embodiments disclosed herein are exemplary and not limiting embodiment,

Thus, the invention disclosed herein is not limited to the exemplary embodiments disclosed.

[0037]

Continuing to refer to FIG. 1, the camera 10 may include a body or housing 12, which is configured to support Configured for detection, treatment, and, optionally, storage and / or play video image data system 14.

For example, system 14 may include an optical hardware 16, an image sensor 18, image processing module 20, Compression module 22, and a memory 24.

Alternatively, the camera 10 may further include a monitor mode

Block 26, a playback module 28, and a display 30.

[0038]

Figure 2 illustrates a non-limiting exemplary embodiment of the camera 10.

Figure 2

Shown, the optical hardware 16 through the outer surface of the housing 12 so as to expose a manner to support.

In some embodiments, the system 14 supported in the housing 12.

For example, the image sensor 18,

The image processing module 20, and a compression module 22 may housed in the housing 12.

Memory device 24

It can be installed in the housing 12.

Further, in some embodiments, the memory device 24 may be mounted

In the outer housing 12 and is connected to the system by any type of known connector or cable

The remaining portion 14.

Further, the memory device 24 may be a flexible cable is connected to the housing 12, from

While allowing the storage device 24 in a degree of independence in 12 mobile housing.

For example, by this

Species flexible cable connector, the memory device 24 can be worn on the user's belt, allowing the housing 12

The total weight loss.

Further, in some embodiments, the housing may comprise in its interior

And installed it an external or more memory devices 24.

In addition, the housing 12 may also support

Monitor support module 26, and the playback module 28.

Notice

This translation is machine-generated. It cannot be guaranteed that it is intelligible, accurate, complete, reliable or fit for specific purposes. Critical decisions, such as commercially relevant or financial decisions, should not be based on machine-translation output.

Further, in some embodiments, the display 30 may be configured to be mounted in the outer housing 12.

[0039]

The optical hardware 16 may be configured to focus incoming image to the image sensor 18, Having the form of at least one lens of the lens system. Optics hardware 16, optionally, can be provided with a zoom, focus and aperture form a multi-lens system. Furthermore, the optical hardware 16 may be supported by the housing and configured to accommodate many different types of the lens system through the lens holder, such as, but not limited to, optical hardware 16 configured to receive a variety of sizes including lens system seat, said system comprising 50-100 mm lens (F2.8) zoom lens, 18-50 mm (F2.8) lens, 300 mm (F2.8) lens, 15 mm (F2.8) lens, 24 mm (F1.9) lens, 35 mm (F1.9) lens, 50 mm (F1.9) lens, 85 mm (F1.9) lens, and / or any other lens. As described above, the optical hardware 16 can be configured so that no matter what lens is attached, the image can be focused onto the image sensor 18 photosensitive surface.

[0040]

The image sensor 18 may be any type of video sensing device, comprising: for example, but are not limited to, CCD, CMOS, such as vertical stacked CMOS sensor device, Or a prism between the sensor spectral multi-sensor array. In some embodiments, The image sensor 18 may include having about 12 million light-sensitive cells of CMOS devices. However, You can also use other dimensions of the sensor. In some constructions, the camera 10 can be configured to "2k" (E.g., 2048 × 1152 pixels), "4k" (e.g., 2096 × 2540 pixels), "4.5k" Horizontal resolution or greater resolution of the output video. As used herein, with xk (e.g., above 2k and 4k) expressed in terms of format, the number of x is substantially horizontal resolution. As such, "4k" Resolution equivalent to about 4,000 or more horizontal pixels, "2k" is equivalent to about 2000 Or more pixels. Using existing commercially available hardware, the sensor can be as small as about 0.5 English Inches (8mm), however, it may be about 1.0 inches, or more. Further, the image Sensor 18 may be configured to selectively output by only a predetermined portion of the sensor 18 to provide variable Of the resolution. For example, the sensor 18 and / or image processing module can be configured to allow the use of Identification image data output resolution.

[0041]

The camera 10 may also be configured for the next processing and then sampling the output of the sensor 18 to produce 2K, 1080p, 720p, or any other resolution of the video output. For example, from the pass The sensor image data 18 may be "sampling window", thereby reducing the output image size and allows Higher reading speed. However, other dimensions of the sensor may be used. In addition, the camera 10 It can be configured for the output of the sensor 18 of the samples to produce higher resolution video output.

Notice

This translation is machine-generated. It cannot be guaranteed that it is intelligible, accurate, complete, reliable or fit for specific purposes. Critical decisions, such as commercially relevant or financial decisions, should not be based on machine-translation output.

[0042]

Referring to Figure 1-3, in some embodiments, sensor 18 may comprise a Bayer pattern Filter.

As such, the sensor 18, by its chipset (not shown) outputs a graph representing the Like the number of units of each of the photosensitive sensor 18 to detect the magnitude of the red, green or blue light Data.

3 schematically illustrates a Bayer pattern sensor output 18.

In some embodiments,

, For example, shown in Figure 3, Bayer pattern filter has twice the number of red cells in The number of units of green and blue elements.

The image sensor chip set 18 may be used to read image

Charge on each unit of the sensor, which in known RGB format output value stream.

[0043]

Referring next to FIG. 4, the image processing module 20 is configured to be optional in any known manner Style format data stream is formed from the image sensor 18.

In some embodiments, the image

The processing module 20 may be configured to green, red and blue image data into three or four Separate data sets.

For example, the image processing module 20 can be configured to be a red data

Data unit, the blue data points to a blue data unit, and the green data to

A green data unit.

For example, referring to FIG. 4, the image processing module 20 may include the number of red

Data processing module 32, the blue data image processing module 34 and the first green image data processing Module 36.

[0044]

However, as described above, as shown in FIG. 3 Bayer pattern data, having twice the other two Colors of green pixels.

Figure 5 shows an example in which the removal of the remaining blue and red data only Data unit original green image data.

[0045]

In some embodiments, the camera 10 can be configured to delete or omit some of the green image Data.

For example, in some embodiments, the image processing module 20 may be configured to delete 1/2

The number of green image data for the total number of green image data and image data of blue and red The same amount.

For example, Figure 6 shows an image processing module 20 the green image data to delete 1/2

After the remaining data.

In the embodiment shown in FIG. 6, it has been deleted rows $n-3$, $n-1$,

$n + 1$ and $n + 3$.

This is only one example of a format that can be deleted green image data.

Also

You can delete a number of other formats and other green image data.

[0046]

In some alternative, the camera 10 can be configured based on the green image data into red

And blue image data deletion green image data after 1/2.

This optional technology will

Having described the image data is subtracted from the other colors of green image data values will be described.

Notice

This translation is machine-generated. It cannot be guaranteed that it is intelligible, accurate, complete, reliable or fit for specific purposes. Critical decisions, such as commercially relevant or financial decisions, should not be based on machine-translation output.

[0047]

Alternatively, the image processing module 20 can be configured to selectively delete green image data. For example, the image processing module 20 may be configured to include a green image data which is selectively determined Deleted deleted analysis module (not shown). For example, such modules can be configured to delete Determining whether to delete a certain format image data from the green line will cause aliasing artifacts (for example, Moire) or other visually perceptible artifacts. Remove module is further configured to Risk choose a certain format, delete the green image data so as to generate the illusion of representing Small. For example, remove the module can be configured to, if it determines that the image captured by the image sensor 18 Including the performance of the image feature multiple parallel horizontal lines, select vertical columns alternating green diagram Delete the image data format. This format can reduce or eliminate Delete Delete parallel probe in the image Remove formatting alternate rows of illusion to the horizontal line of the image data can be generated, for example, MO Seoul stripes.

[0048]

However, this is only the image feature modules can be removed and used to delete the format type An exemplary, non-limiting examples. Remove module can also be configured to detect other image Features and other image data deletion format, such as, but not limited to, alternating rows, alternating Diagonal, or delete other formats. In addition, the module can be configured to delete delete other figures Part of the image data (for example, red and blue image data), or by the use of sensor Other types of image data decision.

[0049]

Further, the camera 10 can be configured to be inserted in a data field to indicate the image data deleted What image data. For example, but not limited to, the camera 10 can be configured as 24 in the memory device At the beginning of the stored video clips to insert any data field to indicate the video clip Each "frame" what data is deleted. In some embodiments, the camera can be configured Each frame captured by the sensor 18 in the insert data fields to indicate what the image is deleted Data. For example, in the image processing module 20 is configured to press a Delete to delete the 1/2 format Some embodiments of the green image data, the data field can be as small as one-bit data word Section to indicate whether to delete the image data. Because the image processing module 20 is configured to press only one A format to delete data, one bit is sufficient to indicate what data is deleted.

[0050]

In some embodiments, as described above, the image processing module 20 can be configured to more A format to selectively delete image data. Thus, the image data can delete fields Larger, including a sufficient number of values is used to provide an indication of the different image data deletion In addition to the format in which one. The data fields or by downstream components and process used to determine

Notice

This translation is machine-generated. It cannot be guaranteed that it is intelligible, accurate, complete, reliable or fit for specific purposes. Critical decisions, such as commercially relevant or financial decisions, should not be based on machine-translation output.

The remaining image data corresponding to a given position in which space.

[0051]

In some embodiments, the image processing module can be configured to retain all of the original Green Image data, e.g., data shown in Figure 5.

In these embodiments, the image processing module
It may include one or more green image data processing module.

[0052]

As described above, in known Bayer pattern filters having twice the red cell
The number of green and blue number of unit cells.

In other words, the red cell contains a total Bayer
25% of the pattern array, the blue cell is 25% of the Bayer pattern array, the green unit comprising
50% Bayer pattern array elements.

Thus, while retaining all of the green image data

In some embodiments, the image processing module 20 may include a second green data image processing module
38.

As such, the first green data image processing module 36 can handle half of the green cells, the first
Two green image data processing module 38 may process the remaining green cells.

However, the present invention may be

In conjunction with other types of patterns, such as, but not limited to, CMY and RGBW.

[0053]

Figure 7 comprises a module 32, 34 and 38 by the red (FIG. 4) processing, and two blue
Green data components shown schematically.

This may provide a further advantage, because these modes

The size and configuration of each block is substantially the same, because they deal with roughly the same number
of number

Data.

Further, the image processing module 20 selectively switching processing in which all of the green diagram
Image data (through the use of modules 36 and 38) model and which to remove a 1/2 green image

Mode between data (of which only the use of modules 36 and 38 a).

However, it may also be

Other configurations.

[0054]

Further, in some embodiments, the image processing module 20 may include other modules, and /

Or may be configured to perform other processing, such as, but not limited to, gamma correction processing, too
noisy

Filtration treatment and the like.

[0055]

Further, in some embodiments, the image processing module 20 can be configured from the blue cells
And Value / or red cells subtracted value for the green units.

As such, in some embodiments,

When it detects certain color by the image sensor 18, and the corresponding units can be red or blue
Reduced to zero.

For example, in a lot of photography, there are large areas of black, white, or gray
Color, or the transition from gray to red or blue color.

Thus, if the image sensor

Pixels corresponding to a measured sense 18 gray, green, red and blue will be approximately equal magnitude.

Thus, if the value is subtracted from the red green and blue values, the red and blue values will be reduced to zero or
We are close to zero.

Thus, in the subsequent compression process, the sense of black, white or gray blocks

Pixel will generate more zero, the data thus generated will have greater compressibility.

Notice

This translation is machine-generated. It cannot be guaranteed that it is intelligible, accurate, complete, reliable or fit for specific purposes. Critical decisions, such as commercially relevant or financial decisions, should not be based on machine-translation output.

In addition, for other reasons, you can subtract green color from the other one or both. Image data is generated more compressibility.

[0056]

This technique, because the relationship between the original image data with the entropy between, contribute to More efficient compression ratio and remains visually lossless.

For example, the entropy of the image with the image with
The amount of the relevant machine.

For example, a color image is subtracted from the other colors in the image data
It can reduce random, thereby reducing the entropy of the color image data, thus allowing data to
A higher compression ratio and less loss is compressed.

Set Typically, the image is not a random color value
Co.

Therefore, this technique can be used by subtracting the correlation unit to achieve better compression.

Press

Shrinkage will depend at least in part, the original image information entropy.

[0057]

In some embodiments, the subtracted from the red or blue pixel values can be from
Save money with the red or blue pixels adjacent to the green pixel output value.

Further,

In some embodiments, the subtracted from the red or green blue cell value from weeks
Surrounded by green stars mean unit.

This technique is described in more detail below.

But also

You can use other techniques.

[0058]

Alternatively, the image processing module 20 may be configured to selectively subtracted from the other colors
Green image data.

For example, the image processing module 20 may be configured to determine whether any of the other colors
Whether part of an image data by subtracting the green image data to provide better compression

Sex.

In this mode, the image processing module 20 can be configured to insert a marker in the image data

Amended to indicate what part of the image data (for example, by subtracting the green image data modification)

And which part is not modified.

These markers, downstream to the Mosaic / reconstruction component can be based on this

These data marked state green image values selectively add back other color image data

In.

[0059]

Alternatively, the image processing module 20 may also include a configuration for the red and blue data rounding
(Rounding) of additional data reduction module (not shown).

For example, if the minus

After the red or blue green amplitude data close to zero (for example, in the range of 0-255 8

Bit value is within the range of 1 or 2 or higher on higher resolution systems

Amplitude).

For example, the sensor 18 may be in the range 0-4095 to output red value,

12 sensor data of blue and green.

Rounding any rounding performed on the data module or

Filtering can be adjusted to achieve the desired effect.

For example, if desired lossless output, compared with places

Small degree rounding; and if an acceptable loss of some or loss of output, larger places

The level of implementation.

You can perform some rounding and still produce visually lossless output.

For example,

Notice

This translation is machine-generated. It cannot be guaranteed that it is intelligible, accurate, complete, reliable or fit for specific purposes. Critical decisions, such as commercially relevant or financial decisions, should not be based on machine-translation output.

By 8-bit range of values, up to 2 or 3 having an absolute value of the red or blue data
It may be rounded to zero and still provide visually lossless output.
Further, according to the 12-bit range of values,
Having up to 10-20 absolute red or blue data can be rounded to zero and still provide
Visually lossless output.

[0060]

In addition, rounded to zero or rounded to a different value, and still provide visually lossless output
The value depends on the magnitude of the configuration system, comprising an optical hardware 16, an image
sensor 18, FIG.
The resolution of the image sensor, the image sensor 18 color resolution (bits), the filter class
Type, the image processing module 20 performs anti-aliasing techniques or other techniques, compression module
22
Compression technology implementation, and / or camera parameters or other features 10.

[0061]

As described above, in some embodiments, the camera 10 can be configured based on the green image
After data transformation the red and blue image data, green image data delete 1/2.
For example,
But not limited to, the processing module 20 may be configured to subtract from the red and blue data values around
the green
After the average value of color data values, delete the green image data of 1/2.
Green Data
The throughput of this reduction can reduce the demand for related hardware.
In addition, the remaining green diagram
Image data can be used to reconstruct the red and blue image data, will be 14 and 16 in greater detail
Finely description.

[0062]

As described above, the camera 10 may also include a compression module 22.
Compression module 22 may be a single
In the form of a chip, or may be implemented through software and additional processors.
For example, the compression module
22 may be in the form of commercially available compression chip, which is performed according to standard JPEG
2000
Compression technology, or other compression techniques.

[0063]

The compression module can be configured to perform the data from the image processing module 20, any type
The compression process.
In some embodiments, the compression module 22 performs image processing module
20 performs compression techniques.
For example, as described above, the image processing module 20 can be equipped with
Set amount by subtracting the magnitude of the green image data to reduce the value of the red and blue data
Value, resulting in more zero values, and other effects.
Further, the image processing module 20
Perform operations using the image data of the entropy of the original data.
Thus, the compression module 22
Perform compression technology for such types: the emergence of zero to benefit from its larger string to reduce
The size of the compressed data output.

[0064]

Further, the compression module 22 may be configured to compress the image from the image processing module 20
Data to produce visually lossless output.
For example, first, the compression module can be configured to apply

Notice

This translation is machine-generated. It cannot be guaranteed that it is intelligible, accurate, complete, reliable or fit for specific purposes. Critical
decisions, such as commercially relevant or financial decisions, should not be based on machine-translation output.

Any known compression techniques, such as, but not limited to, JPEG 2000, JPEG activities (MotionJPEG), any DCT-based codec, designed to compress any RGB Codec of the image data, H.264, MPEG4, Huffman, or other techniques.

[0065]

Depending on the type of compression technology, various parameters can be set to provide compression technology to

Visually lossless output.

For example, many of the above-described compression techniques adjusted to different compression rates, Wherein when decompressed, the resulting image is of a low compression ratio of better quality, while the high compression ratio

It is of lower quality.

Thus, the compression module can be configured to provide visually lossless output

Mode compressed image data, or may be configured to allow the user to adjust various parameters to obtain a visual Sleep lossless output.

For example, the compression module 22 can be configured to approximately 6:1,7:1,8:1

Or greater compression rate to compress the image data.

In some embodiments, the compression module 22

It can be configured to compress the image data 12:1 ratio or higher.

[0066]

Further, the compression module 22 may be configured to allow the user to adjust the compression module 22 via the solid

Now the compression ratio.

For example, camera 10 may include a user interface that allows the user to input the pressing

Reduction module 22 changes the compression ratio of the command.

Thus, in some embodiments, the camera 10 may

Providing a variable compression.

[0067]

As used herein, the term "visually lossless" is intended to include such an output: When the same

The display on the original (never compressed) image data side by side comparison, based solely on

Visual image, one of ordinary skill in the art will not determine which image is a reasonable

The accuracy of the original image.

[0068]

Continuing to refer to FIG. 1, the camera 10 may also include a memory device 24.

Memory device may be any

In the form of any type of digital storage, such as, but not limited to, a hard disk, flash memory or any

Other types of memory devices.

In some embodiments, the size of the memory device 24 is large enough to

Storing the image data from the compression module 22, which corresponds to 12 mega pixel resolution, 12-bit color

At least about 30 minutes of video color resolution and 60 frames per second.

However, the memory device 24

You can have any size.

[0069]

In some embodiments, the memory device 24 may be mounted on the outside of the housing 12.

Into a

Step, in some embodiments, the memory device 24 may be connected to the system via a standard communication port

14 other member, said port including, for example, but not limited to, IEEE 1394, USB 2.0,

IDE, SATA, and so on.

Further, in some embodiments, the memory device 24 may comprise

According to the agreement operate multiple RAID hard drive.

Notice

This translation is machine-generated. It cannot be guaranteed that it is intelligible, accurate, complete, reliable or fit for specific purposes. Critical decisions, such as commercially relevant or financial decisions, should not be based on machine-translation output.

However, you can use any type of memory Member.

[0070]

Continuing to refer to FIG. 1, as described above, in some embodiments, the system may include monitoring Module 26 and the display device 30 is configured to allow users to watch during operation by FIG.

The image sensor 18 to capture video images.

In some embodiments, the image processing module 20

Can be configured to include a reduced resolution image data is output to a secondary monitor module 26 Sampling systems.

For example, such a subsampling system can be configured to output video image data to support Hold 2K, 1080p, 720p or any other resolution.

In some embodiments, for

Demosaicized filter may also be adapted to the next sampling filter for down-sampling and filtering may Simultaneously.

Monitor module 26 can be configured to perform data from the image processing module 20

Demosaicking processing lines of any type.

Thereafter, the monitor module 26 can output demosaicized

Image data to the display 30.

[0071]

Display 30 may be any type of monitoring device.

For example, but not limited to, a display

30 may be supported by the housing 12 four inches LCD panel.

For example, in some embodiments,

Wherein the display 30 may be connected to an unlimited number of adjustments, which is configured to allow the display 30 with

For housing 12 is adjusted to any position, so that the user can phase 12 housing for any angle

Watch the display 30 degrees.

In some embodiments, the display 30 can be any type of

Video cable, for example, RGB or YCC format video cables to connect to the monitor module.

[0072]

Alternatively, the playback module 28 may be configured to receive data from the storage device 24, for Image data is decompressed and de-mosaic, and then outputs the image data to the display 30.

In one

In some embodiments, the monitor module 26 and the playback module 28 through an intermediate display controller (Not shown) is connected to the monitor.

As such, the display 30 may be connected to a single connector

The display controller.

The display controller can be configured from the monitor module 26 or play module 28

Transferring data to the display 30.

[0073]

Figure 8 shows a camera 10 includes an image data processing flowchart 50.

In some

Embodiment, the flowchart may represent a storage device 50 (e.g., memory devices 24 store

Or the camera 10 in another storage device (not shown)) of the control process.

In addition, the

Central processing unit (CPU) (not shown) may be configured to perform the control process.

Next, the corresponding

50 is a flowchart of a method in the case of processing a single frame of video image data into a description in

Line introduction.

Thus, this technique can be applied to the processing of a single still image.

These processes

Also applicable to the processing of continuous video, e.g., frame rate greater than 12, and 20,23.976,

Notice

This translation is machine-generated. It cannot be guaranteed that it is intelligible, accurate, complete, reliable or fit for specific purposes. Critical decisions, such as commercially relevant or financial decisions, should not be based on machine-translation output.

Frame rate 24,30,60 and 120, or between the frame rate or more other frames
Frequency.

[0074]

With continued reference to FIG. 8, the control flow may begin operating block 52.
In operation block 52, phase
(10) availability of sensor data.
For example, referring to FIG. 1, may comprise a core and a Bayer sensor
Slice group image sensor 18 may output image data.

[0075]

For example, without limitation, with reference to FIG. 3, the image sensor may comprise a mask in which a light-
receiving
There Bayer pattern filter CMOS devices.
Thus, the focus from the optical hardware 16
Bayer pattern filter image focused onto the CMOS image sensor 18 on the device.
Figure 3
It shows the arrangement of a Bayer pattern filter through the CMOS devices produced by Bayer mold
An example of style.

[0076]

In Figure 3, column m is the origin of the Bayer pattern from the left in the fourth column, and row n is from
On the edge of the format from the fourth row.
The rest of the rows and columns with respect to the column m and row n to mark.
However, this arrangement is for illustrative purposes only randomly selected, not limiting herein disclosed
Any embodiment and invention.

[0077]

As described above, the known Bayer pattern filter typically includes twice the blue and red
Unit of green cells.
In the pattern of Figure 5, blue elements only appear in the row $n-3$, $n-1$,
 $n+1$ and $n+3$ in.
Red cell line appears only $n-2$, n , $n+2$ and $n+4$ in.
However,
Green cells appear in all rows and columns, interspersed with red and blue elements.

[0078]

Thus, in operation block 52, the red output from the image sensor 18, blue and green
Color image data received by the image processing module 20, and the organization as a separate color data points
The amount of, for example, those shown in Figure 7.
As shown in Figure 7, as described above with reference to FIG. 4,
The image processing module 20 may be red, blue and green image data is divided into four separate points
The amount.
Figure 7 shows two green component (Green 1 and Green 2), a blue component and
A red component.
However, this is only processed image data from the image sensor 18 is a
Exemplary methods.
Further, as described above, alternatively, the image processing module 20 can be random or
By selectively delete 1/2 green image data.

[0079]

After the operation block 52, a flowchart 50 to advance to the operating block 54.
In operation block 56
, The image data may be further processed.
For example, alternatively, the number may be generated by further processing

Notice

This translation is machine-generated. It cannot be guaranteed that it is intelligible, accurate, complete, reliable or fit for specific purposes. Critical decisions, such as commercially relevant or financial decisions, should not be based on machine-translation output.

According to any one or all of (e.g., green 1, green 2, the blue image from the FIG. 9 And red image data from the data of FIG. 10).

[0080]

For example, pre-emphasis, or otherwise process the image data.
In some embodiments,
, The image data can be handled more (mathematically) nonlinearity.
Some compression algorithms benefit
This compression of the execution unit before linearization.
However, other techniques may also be used.
For example,
Image data can be linear curve processing, it basically does not provide increased.

[0081]

In some embodiments, the operation block 54 may be defined by a function using $0.5 y = x ^ \wedge$ curve
To process the image data.
In some embodiments, the curve of the image data, e.g.
But not limited to, the use of normalized floating point data when the 0-1 range.
In other embodiments,
For example, when the image data as 12-bit data, use the curve $y = (x / 4095) ^ 0.5$ to handle Figure
Like.
Moreover, other curves may be used to process the image data, e.g., $y = (x + c) ^ g$, wherein
 $0.01 < g < 1$, and c is an offset, c in some embodiments may be 0.
In addition, but also to
Logarithmic curve.
For example, in the form $y = A * \log (B * x + C)$ curve, wherein, A, B, and C
Is selected to provide the desired constant result.
In addition, you can modify the above curve and methods
Offer a more linear region in a black neighborhood, like in a well-known gamma correction Rec709
Use of those techniques in the middle.
When the process is applied in the image data, allowing the same
Process is applied to all of the image data, or may be different treatment applied to different colors
Image data.
However, these are merely exemplary curves can be used to process the image data, but also
Other curves may be used or converted.
In addition, you can use math functions such as those described above,
Or look-up tables (LUTs) to apply the processing technology.
Further, different processing techniques
Or transformation may be used for different types of image data, the image data recorded using different
ISO setting temperature (which can affect noise levels), and so on.

[0082]

After the operation block 54, a flowchart 50 to advance to the operating block 56.
In operation block 56
, You can change the red and blue elements.
For example, as described above, from the blue and red image
Subtracting each data component green image data.
In some embodiments, the red
Or blue image data value by subtracting at least one green near the red or blue unit
Green image data values to change the color unit.
In some embodiments, from red or
Blue image data values in a plurality of adjacent green cells subtracting average data values.
For example,
But not limited to, calculate the average value of 2,3,4 or more green image data values, and
It will be subtracted from the nearby red or green cells blue unit.

Notice

This translation is machine-generated. It cannot be guaranteed that it is intelligible, accurate, complete, reliable or fit for specific purposes. Critical decisions, such as commercially relevant or financial decisions, should not be based on machine-translation output.

[0083]

For example, without limitation, with reference to FIG. 3, the raw output of the red cell Rm-2, n-2 are four green Color unit Gm-2, n-3, Gm-1, n-2, Gm-3, n-2, and Gm-2, n-1 around.

Thus, the red cell Rm-2, n-2 can

It follows by subtracting the average value of the surrounding green cells to transform:

[0084]

$$(1) R_{m, n} = R_{m, n} - (G_{m, n-1} + G_{m+1, n} + G_{m, n+1} + G_{m-1, n}) / 4$$

[0085]

Similarly, the blue unit as follows similarly by subtracting the average of the surrounding green cells Ways to transform:

[0086]

$$(2) B_{m+1, n+1} = B_{m+1, n+1} - (G_{m+1, n} + G_{m+2, n+1} + G_{m+1, n+2} + G_{m, n+1}) / 4$$

[0087]

Figure 9 shows a case where the raw blue raw data Bm-1, n-1 converted the resulting blue number According to the component, the new value is marked B'm-1, n-1 (the component is filled with a value only, and the same technology

Available for all the blue cells).

Similarly, Figure 10 illustrates the red data has been transformed

Components, wherein the red cell transformed Rm-2, n-2 labeled R'm-2, n-2.

In this state,

Image data is still considered to be "raw" data.

For example, the complete implementation of the mathematical data processing

Full reversible, so that you can to get all of the original value by reverse those processes.

[0088]

With continued reference to FIG. 8, after the operation block 56, the flowchart 50 proceeds to the operation block 58 can be.

In operation block 58, and the resulting data (which is the original or substantially original) can use either

Any known compression algorithms to further compression.

For example, the compression module 22 (FIG. 1) can be configured

To perform compression algorithms such.

After compression, the original data can be stored in the memory

Member 24 (FIG. 1).

[0089]

8A illustrates a modification of the flowchart 50, numerical reference 50 'is marked.

Above-mentioned

Referring to a flowchart of steps 50, 50 may be similar to a flowchart of 'some of the steps or

The same, and thus the same reference numbers marked.

[0090]

8A, in some embodiments, a flowchart 50 'Optionally ignore operation block

54.

In some embodiments, a flow chart 50 'may also include the operation block 57, in which the image

Data application lookup table.

For example, an optional look-up table, the curve represented in FIG. 11, can be

Notice

This translation is machine-generated. It cannot be guaranteed that it is intelligible, accurate, complete, reliable or fit for specific purposes. Critical decisions, such as commercially relevant or financial decisions, should not be based on machine-translation output.

For increasing further compression.

In some embodiments, the lookup table in Figure 11 only for Green cells.

In other embodiments, the lookup table can be used for the red and blue elements.

Phase

The lookup table can be used with three different colors, or each color may have its own check Look-up table.

In addition, it can also be applied in addition to the plot as reflected in the 11.

[0091]

8 by way of the above and with reference to FIG. 8A to process the image data, it has been found, Data from the image sensor 18 may 6:1 or greater compression ratio to compress and still Maintaining visual lossless.

Further, although the image data has been transformed (e.g., FIG green Minus data like), but all of the original image data is still available to the end user.

For example, by reverse certain processes, you can extract all or substantially all of the raw data, And using any method desired by the user for further processing, filtering and / or de-mosaic.

[0092]

For example, referring to FIG. 12, can be decompressed data stored in the storage device 24 in and Demosaicing.

Alternatively, the camera 10 can be configured to perform 60 shows a flowchart of a method.

Case

Such as, but not limited to, player module 28 may be configured to perform 60 shows a flowchart of a method.

But

That the user can also be separated from the data to the storage device 24 transfer stations, and application flows Chart 60 in any or all of the steps and / or operations.

[0093]

Continuing to refer to FIG. 12, a flowchart 60 may begin operation block 62, from which the storage Data on the device 24 to decompress.

For example, the operation of the data decompression block 62 can be operated

As block 58 (FIG. 8) Reverse compression algorithms executed.

After the operation block 62, the flowchart

60 to advance to the operating block 64.

[0094]

In operation block 64, the method of operation of the block (FIG. 8) can be performed in reverse 56.

For example,

You can reverse the curve of FIG. 11 or above with reference to FIG. 8 and 8A of the operating block 56

Any reverse applied to the image data of other functions.

Operation block 64, a flow chart 60 may

Proceeds to step 66.

[0095]

In operation block 66, the unit can go green mosaic.

For example, as described above,

From green data components and / or green 2 (Figure 7) for all values can be stored in the memory device 24.

For example, referring to FIG. 5, from the data components Green 1, Green 2 green image

It is in accordance with the original Bayer pattern image sensor 18 arranged in the application.

Then, the green

Data can be further demosaiced by any known technique, for example, linear interpolation, two-Sex and so on.

Notice

This translation is machine-generated. It cannot be guaranteed that it is intelligible, accurate, complete, reliable or fit for specific purposes. Critical decisions, such as commercially relevant or financial decisions, should not be based on machine-translation output.

[0096]

Figure 13 shows all of the original image data to a mosaic of green after green image
An exemplary layout data.

Green image letter Gx unit mark represents the original (decompression
A) image data, and marked by DGx unit represents demosaic processing from the original
Data derived units.

The term is used in the following procedure demosaicking other colors.

Figure 14

It shows an example of the original image data of 1/2 to green after green mosaic image data
The layout of the image data.

[0097]

Continuing to refer to FIG. 12, a flowchart 60 may be performed after the operation block 66 proceeds to the
operation block 68.

In operation block 68, the green image data may be further processed after demosaicized.

For example, but

It is not limited to, noise removal techniques can be applied green image data.

However, any other image

Processing technology, for example, an anti-aliasing technique can also be applied to the green image data.

Operation block 68

Thereafter, the flow chart 60 to advance to the operating block 70.

[0098]

In operation block 70, it can be red and blue image data to the mosaic.

For example,

First, the blue image data of Figure 9 can (FIG. 15) according to the original Bayer pattern rearranged.

Around the unit, as shown in Figure 16, may be used any known demosaicing technique, including linear
Interpolation, bilinear, etc., to perform demosaicing existing blue image data.

As a go

Results mosaic step, for each pixel will be blue image data, as shown in Figure 16.

However, the modification of FIG. 9 based on the blue image data, i.e., which is subtracted from the green image
Blue image data values data values, the blue image data to the mosaic.

[0099]

Operating block 70 may also include red image data to the mosaic process.

For example, from

Red image data of Fig. 10 may be rearranged according to the original Bayer pattern, and by any already
Demosaicking known methods such as linear interpolation, bilinear, etc., further to the mosaic.

[0100]

After the operation block 70, a flowchart of the operation can proceed to block 72.

In operation block 72, may

Reconstruction demosaicized red and blue image data according to the green image data to the mosaic.

[0101]

In some embodiments, each of the red and blue image data elements are available through

Plus green image unit from the position at the same (and columns "m" and the line at the same position of "n"
Green picture elements) to reconstruct the green value.

For example, after going mosaic, blue image

It includes a blue element value DBm-2, n-2.

Because the original Bayer pattern Figure 3. In this position does not

Including blue cells, so the blue value DBm-2, n-2 is based on, for example from unit Bm-3, n-3,
Bm-1, n-3, Bm-3, n-1 and Bm-1, n-1, or any other technique or other blue image elements in blue
Color values, derived by the above demosaicking process.

Notice

This translation is machine-generated. It cannot be guaranteed that it is intelligible, accurate, complete, reliable or fit for specific purposes. Critical
decisions, such as commercially relevant or financial decisions, should not be based on machine-translation output.

As shown above, the values in the operation block (FIG. 8) has been modified, and thus does not correspond to the image sensor 18 to detect the original blue image Data.

Rather, from each of these values by subtracting the average green value already.

In this way,

Blue image data generated DBm-2, n-2 also represents the image data has been subtracted green blue Data.

Thus, in one embodiment, the unit DGM-2, n-2 demosaicing the green image

Data can be added to the blue image value DBm-2, n-2, the resulting reconstructed blue image data value.

[0102]

In some embodiments, optionally, the blue and / or red image data can go Marseille G before the first reconstruction.

For example, the blue image data conversion B'm-1, n-1 can be added by first week

Around the mean green cells to reconstruct.

This will lead to gain or to recalculate the original blue picture

Image data Bm-1, n-1.

The process can be performed on all blue image data.

Next, a blue image

Data can be further demosaicized by any known demosaicing techniques.

Red image data

It can also be the same or similar manner.

[0103]

Figure 12A shows a modification of the flowchart 60, numerical reference 60 'is marked.

Said Senate

According to a flowchart of steps 60, and a flow chart 60 'of some of the steps to be similar to or the same as,

Thus the same reference numbers marked.

[0104]

12A, a flow chart 60 'may include an operation block 62 after the operation block 68'.

In

Operating block 68 ', you can perform image data noise removal technology.

Such as, but not limited to, noise

Sound removal techniques can be applied to the green image data.

However, any other image processing technology,

Such as anti-aliasing technique can also be applied to the green image data.

Operating block 68 ', the flow chart

To advance to the operating block 70 '.

[0105]

In operation block 70 ', you can go to the mosaic image data.

As described above with reference to the operation block 66

And the 70, green, red and blue image data can be performed in two steps to the mosaic.

However,

In the current flow chart 60 ', all three colors of the image data to the mosaic embodied in a single

Step, although the same demosaicing techniques described above can be applied to this demosaic process.

Speak

After the work piece 70 ', the flowchart proceeds to an operation block 72 can operate faster and 64, the operating

block 72 may

Reconstruction of the red and blue image data, operation block 64 can be applied to the reverse lookup table.

[0106]

In the flow chart 70 or 70 'in any one or any other suitable method

After extracting and processing the image data, the image data can be further processed image to mosaic

Notice

This translation is machine-generated. It cannot be guaranteed that it is intelligible, accurate, complete, reliable or fit for specific purposes. Critical decisions, such as commercially relevant or financial decisions, should not be based on machine-translation output.

Data.

[0107]

Before reconstruction by the red and blue image data for green image data to Marseille G, some further advantages can be achieved.

For example, as noted above, the human eye to green light more Sensitive.

Green image data to the mosaic and processing optimization of the human eye is more sensitive to green Image value.

In this way, then red and blue image data reconstruction will be on green image Effect of process data.

[0108]

In addition, Bayer pattern has twice the red and blue cells green cells.

In this way,

While retaining all the green data embodiment, with red or blue image data components Compared unit has twice the green image data.

Thus, to the mosaic technique, filter

And other image processing techniques to produce better demosaicing, sharpening or additional filtering Images.

These values are used to reconstruct the mosaic to red and blue image data and go

Mosaic will benefit with the higher resolution of the original data associated with spread of red green and blue single Yuan's treatment, rehabilitation and demosaicing.

As such, the resulting image is further enhanced.

Notice

This translation is machine-generated. It cannot be guaranteed that it is intelligible, accurate, complete, reliable or fit for specific purposes. Critical decisions, such as commercially relevant or financial decisions, should not be based on machine-translation output.

CLAIMS

[0001]

A video camera, comprising:
Portable housing;
A lens assembly supported by the housing and configured for focusing light;
Photosensitive device, which is configured to at least about 23 per second frame rate of the focused light into raw image data of at least 2k resolution;
Memory devices; and
The image processing system, configured as a compression ratio of at least 6 to 1 and remains substantially visually lossless, and at a rate of at least about 23 per second, compressing the raw image data and stored in the storage device.

[0002]

Camera as claimed in claim 1, wherein said image processing system further comprises an image processing module configured to modify the image data representing the first and at least one of the second color is based on the third color image data.

[0003]

Camera as claimed in claim 2, wherein said third color is green

[0004]

Camera as claimed in claim 2, wherein said image processing module is configured for subtracting the third value from the color image data value of said first color and a second color image data.

[0005]

Camera as claimed in claim 2, wherein said image processing system is configured to, after the image processing module of the image data representative of at least one of said first and second colors in a modification, the compression first, second and third color image data.

[0006]

Camera as claimed in claim 2, wherein said image processing system is configured to delete about half of the third representative of the color image data.

[0007]

The second set of camera sensing unit as claimed in claim 6, wherein said photosensitive device comprises a configured to detect a first set of the first color sensing unit configured to detect the second color, and configuration for the detection of a third group of the third color sensing unit, said sensing unit comprises a third set of the second group twice sensing unit of the sensing unit.

[0008]

Camera as claimed in claim 1, wherein said memory device disposed in the housing.

[0009]

Camera as claimed in claim 1, wherein said memory device is supported externally of the housing.

Notice

This translation is machine-generated. It cannot be guaranteed that it is intelligible, accurate, complete, reliable or fit for specific purposes. Critical decisions, such as commercially relevant or financial decisions, should not be based on machine-translation output.

[0010]

Camera as claimed in claim 1, wherein said memory device is connected to the housing by a flexible cable.

[0011]

Camera as claimed in claim 1, wherein said image processing system is configured to operate prior to compressing the original image data to reduce the entropy of the original image data.

[0012]

Camera as claimed in claim 1, wherein said image processing system is configured to entropy before compressing the original image data is reduced.

[0013]

A video camera, comprising:

A lens assembly supported by the housing and configured for focusing light;

Photosensitive device, which is configured to convert the focused light representing the focused light of the original signal at least first, second and third color image data;

An image processing module, configured to the third color image data modifying said first color and the second color image data based on at least one;

Memory devices; and

Compression device configured to compress the first, second, and third color image data, and a frame rate of at least about 23 per second compressed image data is stored to the memory device.

[0014]

Camera as claimed in claim 13, wherein said third color is green.

[0015]

Camera as claimed in claim 13, wherein said image processing module is configured to be subtracted from the value of said first color and a second color image data in at least one of the third color image data value.

[0016]

Camera as claimed in claim 15, wherein the value of said third color image data comprises an average value of the third color of the selected image data.

[0017]

Camera as claimed in claim 13, wherein said image processing module is configured in accordance with the value of the average of at least two adjacent sensing unit calculates the first color sensing unit of the third color image data and subtracting said average value from said first color from said image sensing unit data.

[0018]

The average value of the video camera 17 of the third color image data as claimed in claim, wherein said average includes at least said first color from said sensing means adjacent to the sensor unit, .

[0019]

Camera as claimed in claim 13, wherein said photosensitive device comprises a Bayer sensor.

[0020]

A method of using a video camera to record activity, the method comprising:

Notice

This translation is machine-generated. It cannot be guaranteed that it is intelligible, accurate, complete, reliable or fit for specific purposes. Critical decisions, such as commercially relevant or financial decisions, should not be based on machine-translation output.

The light guide photosensitive device;
At least 23 per second rate greater than said photosensitive device receiving light converted into original digital image data;
Compressing the original digital image data; and
At a rate of at least about 23 per second, the original image data is recorded to the storage device.

[0021]

Steps of a method as claimed in claim 20 wherein, wherein compressing the raw digital image data comprises an effective compression ratio of at least 6 to 1 compression of the original digital image data.

[0022]

The method as claimed in claim 20, wherein the step of compressing the raw digital image data comprises an effective compression ratio of at least about 12 compressed raw digital image data.

[0023]

Steps of a method as claimed in claim 20 wherein, wherein compressing the raw digital image data comprises compressing the raw digital image data to said data holding visually lossless.

[0024]

The method as claimed in claim 20, wherein said recording step comprises storing the compressed raw digital image data.

[0025]

The method as claimed in claim 20, wherein said recording step includes a rate of at least about 23.976 sec recording the raw image data to the storage device.

[0026]

The method as claimed in claim 20 wherein, prior to said recording step further comprises operating said original image data step to reduce the entropy of the original image data.

[0027]

The method as claimed in claim 20 wherein, prior to the recording step, further comprising the step of reducing the entropy of the original image data.

[0028]

The method as claimed in claim 27, wherein, after the step of reducing entropy, further comprising visually lossless manner as the original image data compression.

[0029]

A method of processing an image, comprising:
Convert the image to the original first representing the first color image data representing a second color of the original image data a second, and a third on behalf of a third color of the original image data;
A first modification of the original image data and the second original image data of at least the third image data based on the original;
Compressing the original image data and the third modification of the original first and second original image data;
and
Of at least about 23 per second frame rate of the compressed data is stored.

Notice

This translation is machine-generated. It cannot be guaranteed that it is intelligible, accurate, complete, reliable or fit for specific purposes. Critical decisions, such as commercially relevant or financial decisions, should not be based on machine-translation output.

[0030]

The method as claimed in claim 29, wherein said storing step comprises storing the compressed data to the camera, the camera includes an image sensing device for converting said step.

[0031]

The method as claimed in claim 29, further comprising, remove half of the image data of the third step.

[0032]

The method as claimed in claim 29, wherein said modifying step includes calculating a third average image data of at least two pixels, and is adjacent to the third image data from the at least two pixels of a first subtracting the pixel of the image data of the average value.

[0033]

The method as claimed in claim 32, wherein the calculating step comprises calculating the average of at least a third image data of four pixels.

[0034]

The method according to claim 29, wherein the third image data represents green image data.

[0035]

The method as claimed in claim 29, further comprising a first and second image data and the image data of the third modification will be decompressed.

[0036]

A method according to claim 35, further comprising a third image data to the mosaic.

[0037]

The method according to claim 36, further comprising a third demosaic image data based on the first image data to the mosaic.

[0038]

The method as claimed in claim 36, further comprising the first image data to the mosaic, and then modify the first image data to the mosaic of the third image data based demosaicized.

[0039]

The method as claimed in claim 29, wherein said modifying step includes calculating said third image data based on a value, the value is subtracted from the value of the first image data; and wherein the method further including the third image data and the first and second modified image data is decompressed, for the third image data to the mosaic, followed by the first image data to the mosaic, then based on the demosaicized the value of third image data to modify the first image data to the mosaic.

[0040]

A video camera, comprising:

A lens assembly supported by the housing and configured for focusing light;

Notice

This translation is machine-generated. It cannot be guaranteed that it is intelligible, accurate, complete, reliable or fit for specific purposes. Critical decisions, such as commercially relevant or financial decisions, should not be based on machine-translation output.

Photosensitive device, which is configured to convert the focused light signal representative of the focused light of the original image data;
Memory devices; and
Means for compressing and recording frame rate of at least about 23 per second, the original image data.

[0041]

Camera as claimed in claim 40, further comprising means before entropy compression means for compressing said original image data to reduce the original image data.

[0042]

A video camera, comprising:
Portable housing having at least one handle, and configured to allow a user to operate on at least one of the housing orientation freedom of movement during the recording operation of the video camera;
A lens assembly comprising at least one lens supported by the housing and configured to focus light to a position in the plane of the upper housing;
Photosensitive device, which is configured to at least about 23 per second frame rate of the focused light into at least 2k having a horizontal resolution of the original image data;
A memory device configured to store video image data; and
The image processing system, configured as a compression ratio of at least 6 to 1 and remains substantially visually lossless, and at a rate of at least about 23 per second, compressing the raw image data and stored in the storage device.

[0043]

Camera as claimed in claim 42, wherein said image processing system is configured to entropy in the original image data before compressing the original image data is reduced.

Notice

This translation is machine-generated. It cannot be guaranteed that it is intelligible, accurate, complete, reliable or fit for specific purposes. Critical decisions, such as commercially relevant or financial decisions, should not be based on machine-translation output.



图 1

38

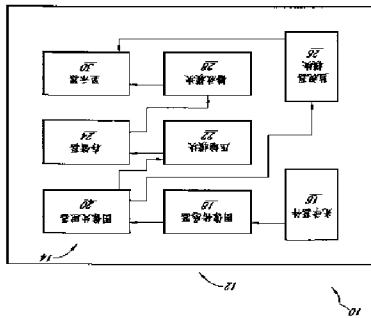

图 2

36

Figure 3 is a grid diagram showing a 10x10 array of elements. The columns are labeled from left to right: m1, m2, m3, m4, m5, m6, m7, m8, m9, m10. The rows are labeled from top to bottom: n1, n2, n3, n4, n5, n6, n7, n8, n9, n10. Each cell in the grid contains the text "Camera".

图 3

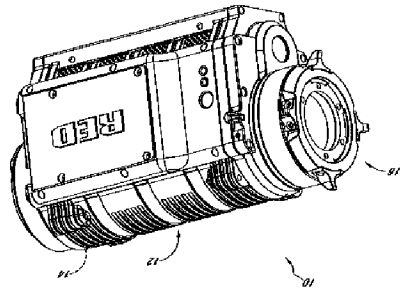
34



图 4

32

Figure 5 is a grid diagram showing a 10x10 array of elements. The columns are labeled from left to right: m1, m2, m3, m4, m5, m6, m7, m8, m9, m10. The rows are labeled from top to bottom: n1, n2, n3, n4, n5, n6, n7, n8, n9, n10. Each cell in the grid contains the text "Camera".

图 5

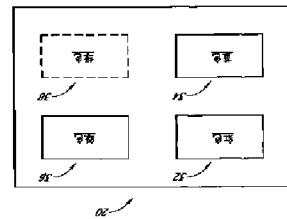
30

Figure 6 is a grid diagram showing a 10x10 array of elements. The columns are labeled from left to right: m1, m2, m3, m4, m5, m6, m7, m8, m9, m10. The rows are labeled from top to bottom: n1, n2, n3, n4, n5, n6, n7, n8, n9, n10. Each cell in the grid contains the text "Camera".

图 6

28

Drawing pages of CN101689357 A

50'



图 8A

50'



图 8

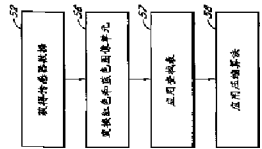

图 7

图 11

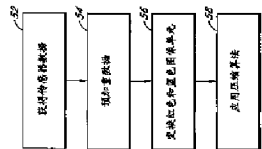

图 10

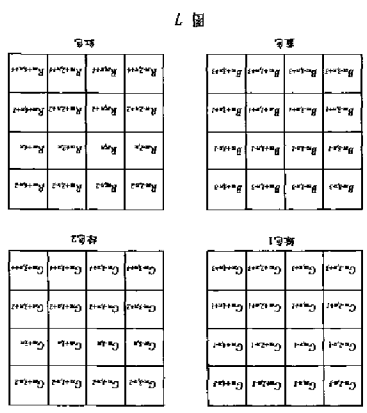

图 9

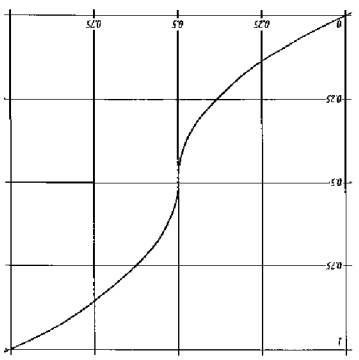

Drawing pages of CN101689357 A

60

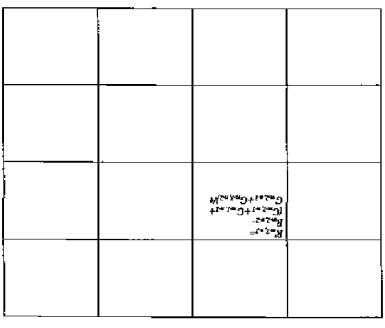
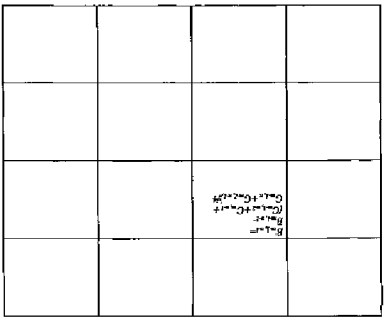

图 12

40

60

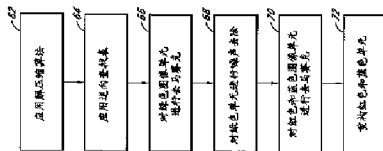

图 12A

41

图 13

n+3	C _{n+3,n+3}	C _{n+3,n+2}	C _{n+3,n+1}	C _{n+3,n}	C _{n+3,n-1}	C _{n+3,n-2}	C _{n+3,n-3}	C _{n+3,n-4}	C _{n+3,n-5}
n+2	C _{n+2,n+3}	C _{n+2,n+2}	C _{n+2,n+1}	C _{n+2,n}	C _{n+2,n-1}	C _{n+2,n-2}	C _{n+2,n-3}	C _{n+2,n-4}	C _{n+2,n-5}
n+1	C _{n+1,n+3}	C _{n+1,n+2}	C _{n+1,n+1}	C _{n+1,n}	C _{n+1,n-1}	C _{n+1,n-2}	C _{n+1,n-3}	C _{n+1,n-4}	C _{n+1,n-5}
n	C _{n,n+3}	C _{n,n+2}	C _{n,n+1}	C _{n,n}	C _{n,n-1}	C _{n,n-2}	C _{n,n-3}	C _{n,n-4}	C _{n,n-5}
n-1	C _{n-1,n+3}	C _{n-1,n+2}	C _{n-1,n+1}	C _{n-1,n}	C _{n-1,n-1}	C _{n-1,n-2}	C _{n-1,n-3}	C _{n-1,n-4}	C _{n-1,n-5}
n-2	C _{n-2,n+3}	C _{n-2,n+2}	C _{n-2,n+1}	C _{n-2,n}	C _{n-2,n-1}	C _{n-2,n-2}	C _{n-2,n-3}	C _{n-2,n-4}	C _{n-2,n-5}
n-3	C _{n-3,n+3}	C _{n-3,n+2}	C _{n-3,n+1}	C _{n-3,n}	C _{n-3,n-1}	C _{n-3,n-2}	C _{n-3,n-3}	C _{n-3,n-4}	C _{n-3,n-5}
n-4	C _{n-4,n+3}	C _{n-4,n+2}	C _{n-4,n+1}	C _{n-4,n}	C _{n-4,n-1}	C _{n-4,n-2}	C _{n-4,n-3}	C _{n-4,n-4}	C _{n-4,n-5}
n-5	C _{n-5,n+3}	C _{n-5,n+2}	C _{n-5,n+1}	C _{n-5,n}	C _{n-5,n-1}	C _{n-5,n-2}	C _{n-5,n-3}	C _{n-5,n-4}	C _{n-5,n-5}

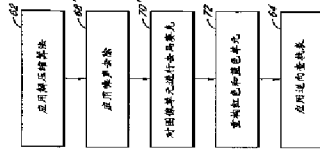
43

60



图 12

40

图 16

n+3	D _{n+3,n+3}	D _{n+3,n+2}	D _{n+3,n+1}	D _{n+3,n}	D _{n+3,n-1}	D _{n+3,n-2}	D _{n+3,n-3}	D _{n+3,n-4}	D _{n+3,n-5}
n+2	D _{n+2,n+3}	D _{n+2,n+2}	D _{n+2,n+1}	D _{n+2,n}	D _{n+2,n-1}	D _{n+2,n-2}	D _{n+2,n-3}	D _{n+2,n-4}	D _{n+2,n-5}
n+1	D _{n+1,n+3}	D _{n+1,n+2}	D _{n+1,n+1}	D _{n+1,n}	D _{n+1,n-1}	D _{n+1,n-2}	D _{n+1,n-3}	D _{n+1,n-4}	D _{n+1,n-5}
n	D _{n,n+3}	D _{n,n+2}	D _{n,n+1}	D _{n,n}	D _{n,n-1}	D _{n,n-2}	D _{n,n-3}	D _{n,n-4}	D _{n,n-5}
n-1	D _{n-1,n+3}	D _{n-1,n+2}	D _{n-1,n+1}	D _{n-1,n}	D _{n-1,n-1}	D _{n-1,n-2}	D _{n-1,n-3}	D _{n-1,n-4}	D _{n-1,n-5}
n-2	D _{n-2,n+3}	D _{n-2,n+2}	D _{n-2,n+1}	D _{n-2,n}	D _{n-2,n-1}	D _{n-2,n-2}	D _{n-2,n-3}	D _{n-2,n-4}	D _{n-2,n-5}
n-3	D _{n-3,n+3}	D _{n-3,n+2}	D _{n-3,n+1}	D _{n-3,n}	D _{n-3,n-1}	D _{n-3,n-2}	D _{n-3,n-3}	D _{n-3,n-4}	D _{n-3,n-5}
n-4	D _{n-4,n+3}	D _{n-4,n+2}	D _{n-4,n+1}	D _{n-4,n}	D _{n-4,n-1}	D _{n-4,n-2}	D _{n-4,n-3}	D _{n-4,n-4}	D _{n-4,n-5}
n-5	D _{n-5,n+3}	D _{n-5,n+2}	D _{n-5,n+1}	D _{n-5,n}	D _{n-5,n-1}	D _{n-5,n-2}	D _{n-5,n-3}	D _{n-5,n-4}	D _{n-5,n-5}

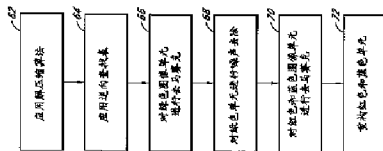
43

图 15

n+3	B _{n+3,n+3}	B _{n+3,n+2}	B _{n+3,n+1}	B _{n+3,n}	B _{n+3,n-1}	B _{n+3,n-2}	B _{n+3,n-3}	B _{n+3,n-4}	B _{n+3,n-5}
n+2	B _{n+2,n+3}	B _{n+2,n+2}	B _{n+2,n+1}	B _{n+2,n}	B _{n+2,n-1}	B _{n+2,n-2}	B _{n+2,n-3}	B _{n+2,n-4}	B _{n+2,n-5}
n+1	B _{n+1,n+3}	B _{n+1,n+2}	B _{n+1,n+1}	B _{n+1,n}	B _{n+1,n-1}	B _{n+1,n-2}	B _{n+1,n-3}	B _{n+1,n-4}	B _{n+1,n-5}
n	B _{n,n+3}	B _{n,n+2}	B _{n,n+1}	B _{n,n}	B _{n,n-1}	B _{n,n-2}	B _{n,n-3}	B _{n,n-4}	B _{n,n-5}
n-1	B _{n-1,n+3}	B _{n-1,n+2}	B _{n-1,n+1}	B _{n-1,n}	B _{n-1,n-1}	B _{n-1,n-2}	B _{n-1,n-3}	B _{n-1,n-4}	B _{n-1,n-5}
n-2	B _{n-2,n+3}	B _{n-2,n+2}	B _{n-2,n+1}	B _{n-2,n}	B _{n-2,n-1}	B _{n-2,n-2}	B _{n-2,n-3}	B _{n-2,n-4}	B _{n-2,n-5}
n-3	B _{n-3,n+3}	B _{n-3,n+2}	B _{n-3,n+1}	B _{n-3,n}	B _{n-3,n-1}	B _{n-3,n-2}	B _{n-3,n-3}	B _{n-3,n-4}	B _{n-3,n-5}
n-4	B _{n-4,n+3}	B _{n-4,n+2}	B _{n-4,n+1}	B _{n-4,n}	B _{n-4,n-1}	B _{n-4,n-2}	B _{n-4,n-3}	B _{n-4,n-4}	B _{n-4,n-5}
n-5	B _{n-5,n+3}	B _{n-5,n+2}	B _{n-5,n+1}	B _{n-5,n}	B _{n-5,n-1}	B _{n-5,n-2}	B _{n-5,n-3}	B _{n-5,n-4}	B _{n-5,n-5}

43

60



图 12

40

图 14

n+3	C _{n+3,n+3}	C _{n+3,n+2}	C _{n+3,n+1}	C _{n+3,n}	C _{n+3,n-1}	C _{n+3,n-2}	C _{n+3,n-3}	C _{n+3,n-4}	C _{n+3,n-5}
n+2	C _{n+2,n+3}	C _{n+2,n+2}	C _{n+2,n+1}	C _{n+2,n}	C _{n+2,n-1}	C _{n+2,n-2}	C _{n+2,n-3}	C _{n+2,n-4}	C _{n+2,n-5}
n+1	C _{n+1,n+3}	C _{n+1,n+2}	C _{n+1,n+1}	C _{n+1,n}	C _{n+1,n-1}	C _{n+1,n-2}	C _{n+1,n-3}	C _{n+1,n-4}	C _{n+1,n-5}
n	C _{n,n+3}	C _{n,n+2}	C _{n,n+1}	C _{n,n}	C _{n,n-1}	C _{n,n-2}	C _{n,n-3}	C _{n,n-4}	C _{n,n-5}
n-1	C _{n-1,n+3}	C _{n-1,n+2}	C _{n-1,n+1}	C _{n-1,n}	C _{n-1,n-1}	C _{n-1,n-2}	C _{n-1,n-3}	C _{n-1,n-4}	C _{n-1,n-5}
n-2	C _{n-2,n+3}	C _{n-2,n+2}	C _{n-2,n+1}	C _{n-2,n}	C _{n-2,n-1}	C _{n-2,n-2}	C _{n-2,n-3}	C _{n-2,n-4}	C _{n-2,n-5}
n-3	C _{n-3,n+3}	C _{n-3,n+2}	C _{n-3,n+1}	C _{n-3,n}	C _{n-3,n-1}	C _{n-3,n-2}	C _{n-3,n-3}	C _{n-3,n-4}	C _{n-3,n-5}
n-4	C _{n-4,n+3}	C _{n-4,n+2}	C _{n-4,n+1}	C _{n-4,n}	C _{n-4,n-1}	C _{n-4,n-2}	C _{n-4,n-3}	C _{n-4,n-4}	C _{n-4,n-5}
n-5	C _{n-5,n+3}	C _{n-5,n+2}	C _{n-5,n+1}	C _{n-5,n}	C _{n-5,n-1}	C _{n-5,n-2}	C _{n-5,n-3}	C _{n-5,n-4}	C _{n-5,n-5}

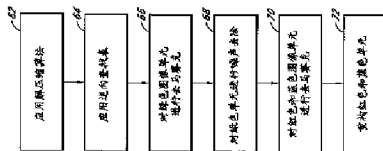
43



[12] 发明专利申请公布说明书

[21] 申请号 200880018570.6

[43] 公开日 2010年3月31日

[11] 公开号 CN 101689357A

[22] 申请日 2008.4.11

[21] 申请号 200880018570.6

[30] 优先权

[32] 2007.4.11 [33] US [31] 60/911,196

[32] 2007.12.28 [33] US [31] 61/017,406

[86] 国际申请 PCT/US2008/060126 2008.4.11

[87] 国际公布 WO2008/128112 英 2008.10.23

[85] 进入国家阶段日期 2009.12.2

[71] 申请人 RED.COM 公司

地址 美国加利福尼亚州

[72] 发明人 詹姆斯·杰纳德

托马斯·格雷姆·纳特瑞斯

[74] 专利代理机构 北京英赛嘉华知识产权代理有
限责任公司

代理人 余 朦 王艳春

权利要求书 7 页 说明书 19 页 附图 18 页

[54] 发明名称

摄像机

[57] 摘要

一种摄像机可配置为以视觉上无损的方式高度压缩视频数据。该摄像机可配置为以提高数据可压缩性的方式对蓝色和红色图像数据进行变换。然后，压缩数据并以这种形式存储。在去马赛克时，对于视觉上无损的原始数据的修改版本，这允许使用者重构红色和蓝色数据以获得原始数据。另外，可按这样的方式处理数据：其中，首先对绿色图像单元进行去马赛克，然后基于去马赛克的绿色图像单元的值来重构红色和蓝色单元。

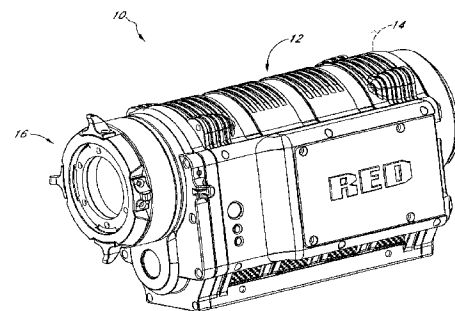

1. 一种摄像机，包括：
便携的壳体；
透镜组件，其通过所述壳体支撑并配置为对光进行聚焦；
光敏器件，其配置为以至少约 23 帧每秒的帧频将聚焦的光转换为至少 2k 分辨率的原始图像数据；
存储器件；和
图像处理系统，其配置为以至少 6:1 的压缩率且基本上保持视觉上无损地、且以至少约 23 帧每秒的速率，压缩所述原始图像数据并将其存储在存储器件中。
2. 如权利要求 1 所述的摄像机，其中，所述图像处理系统进一步包括图像处理模块，其配置为基于第三颜色的图像数据修改代表第一和第二颜色中的至少之一的图像数据。
3. 如权利要求 2 所述的摄像机，其中，所述第三颜色是绿色。
4. 如权利要求 2 所述的摄像机，其中，所述图像处理模块配置为从所述第一颜色和第二颜色的图像数据的值中减去所述第三颜色的图像数据的值。
5. 如权利要求 2 所述的摄像机，其中，所述图像处理系统配置为在所述图像处理模块对代表所述第一颜色和第二颜色中的至少之一的图像数据进行修改之后，压缩所述第一、第二和第三颜色的图像数据。
6. 如权利要求 2 所述的摄像机，其中，所述图像处理系统配置为删除代表所述第三颜色的图像数据的大约一半。
7. 如权利要求 6 所述的摄像机，其中，所述光敏器件包括配置为

探测所述第一颜色的第一组传感单元、配置为探测所述第二颜色的第二组传感单元、和配置为探测所述第三颜色的第三组传感单元，所述第三组传感单元包括两倍于所述第二组传感单元的传感单元。

8. 如权利要求 1 所述的摄像机，其中，所述存储器件设置在所述壳体中。

9. 如权利要求 1 所述的摄像机，其中，所述存储器件支撑在所述壳体的外部。

10. 如权利要求 1 所述的摄像机，其中，所述存储器件通过柔性电缆连接至所述壳体。

11. 如权利要求 1 所述的摄像机，其中，所述图像处理系统配置为在压缩之前操作所述原始图像数据，以减小所述原始图像数据的熵。

12. 如权利要求 1 所述的摄像机，其中，所述图像处理系统配置为在压缩之前减小所述原始图像数据的熵。

13. 一种摄像机，包括：

透镜组件，其通过壳体支撑并配置为对光进行聚焦；

光敏器件，其配置为将聚焦的光转换为代表所述聚焦的光的至少第一、第二和第三颜色的图像数据的原始信号；

图像处理模块，其配置为基于所述第三颜色的图像数据修改所述第一颜色和第二颜色的至少之一的图像数据；

存储器件；和

压缩器件，其配置为压缩第一、第二和第三颜色的图像数据，并以至少约 23 帧每秒的帧频将压缩的图像数据存储至所述存储器件。

14. 如权利要求 13 所述的摄像机，其中，所述第三颜色是绿色。

15. 如权利要求 13 所述的摄像机，其中，所述图像处理模块配置为从所述第一颜色和第二颜色中的至少之一的图像数据的值中减去所述第三颜色的图像数据的值。

16. 如权利要求 15 所述的摄像机，其中，所述第三颜色的图像数据的值包括所述第三颜色的所选图像数据的值的平均值。

17. 如权利要求 13 所述的摄像机，其中，所述图像处理模块配置为根据邻近所述第一颜色的传感单元的至少两个传感单元计算所述第三颜色的图像数据的值的平均值，并从来自所述第一颜色的所述传感单元的图像数据的值中减去所述平均值。

18. 如权利要求 17 所述的摄像机，其中，所述平均值包括至少来自与所述第一颜色的所述传感单元邻近的传感单元的、所述第三颜色的图像数据的值的平均值。

19. 如权利要求 13 所述的摄像机，其中，所述光敏器件包括 Bayer 传感器。

20. 一种使用相机记录活动视频的方法，所述方法包括：
将光导向光敏器件；
以至少大于 23 帧每秒的速率将所述光敏器件接收的光转换为原始数字图像数据；
压缩所述原始数字图像数据；和
以至少约 23 帧每秒的速率将所述原始图像数据记录至存储器件。

21. 如权利要求 20 所述的方法，其中，压缩所述原始数字图像数据的步骤包括以至少 6:1 的有效压缩率压缩所述原始数字图像数据。

22. 如权利要求 20 所述的方法，其中，压缩所述原始数字图像数据的步骤包括以至少约 12:1 的有效压缩率压缩原始数字图像数据。

23. 如权利要求 20 所述的方法，其中，压缩所述原始数字图像数据的步骤包括压缩所述原始数字图像数据，以便所述数据保持视觉上无损。

24. 如权利要求 20 所述的方法，其中，所述记录步骤包括存储压缩的原始数字图像数据。

25. 如权利要求 20 所述的方法，其中，所述记录步骤包括以至少大约 23.976 帧每秒的速率记录所述原始图像数据至所述存储器件。

26. 如权利要求 20 所述的方法，在所述记录步骤之前还包括，操作所述原始图像数据以减少所述原始图像数据的熵的步骤。

27. 如权利要求 20 所述的方法，在记录步骤之前，还包括减少所述原始图像数据的熵的步骤。

28. 如权利要求 27 所述的方法，在减少熵的步骤之后，还包括以视觉上无损的方式压缩所述原始图像数据。

29. 一种处理图像的方法，包括：

将图像转换为代表第一颜色的原始第一图像数据、代表第二颜色的原始第二图像数据、和代表第三颜色的原始第三图像数据；

基于所述原始第三图像数据修改至少所述原始第一图像数据和所述原始第二图像数据；

压缩所述原始第三图像数据和修改的原始第一和原始第二图像数据；和

以至少约 23 帧每秒的帧频存储压缩的数据。

30. 如权利要求 29 所述的方法，其中，所述存储步骤包括存储压缩的数据至相机，所述相机包括用于所述转换步骤的图像传感器件。

31. 如权利要求 29 所述的方法，还包括，删除一半的所述第三图像数据的步骤。

32. 如权利要求 29 所述的方法，其中，所述修改步骤包括计算第三图像数据的至少两个像素的平均值，并从与第三图像数据的所述至少两个像素都相邻的第一图像数据的像素中减去所述平均值。

33. 如权利要求 32 所述的方法，其中，所述计算步骤包括计算第三图像数据的至少四个像素的平均值。

34. 如权利要求 29 所述的方法，其中，所述第三图像数据代表绿色图像数据。

35. 如权利要求 29 所述的方法，还包括对所述第三图像数据和修改的第一和第二图像数据进行解压。

36. 如权利要求 35 所述的方法，还包括对所述第三图像数据进行去马赛克。

37. 如权利要求 36 所述的方法，还包括基于去马赛克的第三图像数据对所述第一图像数据进行去马赛克。

38. 如权利要求 36 所述的方法，还包括对所述第一图像数据进行去马赛克，然后基于去马赛克的第三图像数据修改去马赛克的第一图像数据。

39. 如权利要求 29 所述的方法，其中，所述修改步骤包括基于所述第三图像数据计算一个值，从所述第一图像数据的值中减去所述值；并且其中，所述方法进一步包括对所述第三图像数据以及第一和第二修改的图像数据进行解压，对所述第三图像数据进行去马赛克，接着对所述第一图像数据进行去马赛克，然后基于去马赛克的第三图像数据的值来修改去马赛克的第一图像数据。

40. 一种摄像机，包括：

透镜组件，其通过所述壳体支撑并配置为对光进行聚焦；

光敏器件，其配置为将聚焦的光转换为代表所述聚焦的光的原始图像数据的信号；

存储器件；和

用于以至少约 23 帧每秒的帧频压缩和记录所述原始图像数据的装置。

41. 如权利要求 40 所述的摄像机，还包括用于在用于压缩的装置压缩所述原始图像数据之前减少所述原始图像数据的熵的装置。

42. 一种摄像机，包括：

便携的壳体，其具有至少一个把手，并配置为允许使用者在所述摄像机的视频记录操作期间操作关于所述壳体的至少一个活动自由度的取向；

透镜组件，其包括通过所述壳体支撑的至少一个透镜，并配置为将光聚焦至位于所述壳体中的平面上；

光敏器件，其配置为以至少约 23 帧每秒的帧频将聚焦的光转换为具有至少 2k 的水平分辨率的原始图像数据；

存储器件，其配置为存储视频图像数据；和

图像处理系统，其配置为以至少 6:1 的压缩率且基本上保持视觉上无损地、且以至少约 23 帧每秒的速率，压缩所述原始图像数据并将其存储在存储器件中。

43. 如权利要求 42 所述的摄像机，其中，所述图像处理系统配置为在压缩所述原始图像数据之前减小所述原始图像数据的熵。

摄像机

技术领域

本发明涉及数码相机，例如，用于捕获静止或者活动图像的数码相机，更具体地，涉及压缩图像数据的数码相机。

背景技术

尽管有数码相机可用，但是大多数活动图像和一些电视广播媒体的制作者仍旧依赖胶片摄像机。这里所用的胶片提供给视频编辑者可通过传统方法编辑的很高分辨率的图像。然而，最近，这种胶片常被扫描、数字化和数码编辑。

发明内容

尽管一些目前可用的数码相机包括高分辨率图像传感器，从而输出高分辨率视频；但是，广泛应用在这些摄像机上的图像处理和压缩技术损耗太大，从而消除了太多原始图像数据而无法被上述高端市场接受。这里公开的至少一个实施方式的一个方面包括实现：可被上述高端市场（例如，大多数活动图像市场）接受的视频质量可由这样的相机满足，其可捕获和存储具有至少约 2k 分辨率和至少约 23 帧每秒帧频的原始的或者基本上原始的视频数据。

这样，根据一个实施方式，一种摄像机可包含便携壳体、和通过该壳体支撑并配置为聚光的透镜组件。光敏器件可配置为以至少约 23 帧每秒的帧频将聚焦的光转换为具有至少 2k 分辨率的原始图像数据。该摄像机还可包括存储器件和图像处理系统，图像处理系统配置为以至少约 23 帧每秒的帧频和至少 6:1 的压缩率且基本上保持视觉上无损地压缩和存储原始图像数据到存储器件。

根据另一个实施方式，用相机记录活动视频的方法可包含将光导向光敏器件。该方法还可包括将由光敏器件接收的光转换为具有至少

大于 23 帧每秒帧频的原始数字图像数据、压缩该原始数字图像数据、和将该具有至少约 23 帧每秒帧频的原始图像数据记录到存储器件。

根据又一个实施方式，一种摄像机可包含通过壳体支撑并配置为聚光的透镜组件和配置为将聚焦的光转换为代表该聚焦的光的原始图像数据的信号的光敏器件。该摄像机还可包括存储器件和用于压缩和记录该具有至少约 23 帧每秒帧频的原始图像数据的装置。

根据再一个实施方式，一种摄像机可包含具有至少一个把手的便携壳体，其配置为允许使用者在该摄像机的视频记录操作期间，操作关于该壳体至少一个活动自由度的取向。透镜组件可包含通过该壳体支撑并配置为聚光至在该壳体内布置的平面上的至少一个透镜。光敏器件可配置为将聚焦的光转换为具有至少 2k 水平分辨率和至少约 23 帧每秒帧频的原始图像数据。存储器件还可配置为存储视频图像数据。图像处理系统可配置为以至少约 23 帧每秒的帧频和至少 6:1 的压缩率压缩和存储原始图像数据至该存储器件，而且基本上保持视觉上无损。

这里公开的至少一个实施方式的另一方面包括实现：因人眼对绿色波长比其他任何颜色都更敏感，因此对图像传感器输出的图像数据的基于绿色图像数据的修改可用于提高数据的可压缩性，还提供更高质量的视频图像。这种技术之一可包括在压缩数据之前从探测到的红色和/或蓝色光的量值中减去探测到的绿色光的量值。这可将红色和/或蓝色图像数据转换为更具压缩性的格式。例如，在将伽马校正过的 RGB 数据转换为 $Y' C_b C_r$ 的已知方法中，将图像“去相关”，余下大多数图像数据在 Y' （又名“亮度”），这样，剩余的色度分量更具压缩性。然而，用于转换为 $Y' C_b C_r$ 的已知技术无法直接应用于 Bayer 模式数据，因为各颜色数据空间不相关，Bayer 模式数据包括两倍于蓝色或者红色图像数据的绿色图像数据。根据这里公开的一些实施方式，减去绿色图像数据的方法，可类似于上述 $Y' C_b C_r$ 转换，因为大多数图像数据留在绿色图像数据，使剩余的数据成为更具压缩性的格式。

进一步，可将减去绿色图像数据的过程逆反，以保留所有的原始数据。因此，结合了这一技术所产生的系统和方法可提供无损或者视觉上无损以及提高的视频图像数据的可压缩性。

因此，根据一个实施方式，一种摄像机可包含通过壳体支撑并配置为聚光的透镜组件和配置为将聚焦的光转换为代表该聚焦的光的至少第一、第二和第三颜色的图像数据的原始信号的光敏器件。图像处理模块可配置为基于第三颜色的图像数据来修改第一和第二颜色中至少一个的图像数据。另外，该摄像机可包括存储器件和配置为压缩第一、第二和第三颜色的图像数据并将压缩的图像数据存储到存储器件的压缩器件。

根据另一个实施方式，可提供一种处理图像的方法。该方法可包括：将图像转换为代表第一颜色的第一图像数据、代表第二颜色的第二图像数据和代表第三颜色的第三图像数据；基于第三图像数据来修改至少第一图像数据和第二图像数据；压缩第三图像数据和修改的第一和第二图像数据；以及存储压缩的数据。

根据又一个实施方式，一种摄像机可包含通过壳体支撑并配置为聚光的透镜组件。光敏器件可配置为将聚焦的光转换为代表该聚焦的光的至少第一、第二和第三颜色的图像数据的原始信号。该摄像机还可包括：基于第三颜色的图像数据来修改第一和第二颜色中至少一个的图像数据的装置；存储器件；和配置为压缩第一、第二和第三颜色的图像数据并存储压缩的图像数据到存储器件的压缩器件。

附图说明

图 1 是示出了根据一个实施方式的包括硬件和/或可配置为执行用于处理视频图像数据的方法的一种系统的方框图；

图 2 是图 1 中示意性示出的摄像机的壳体的一个可选实施方式；

图 3 是可用于图 1 中所示系统的具有 Bayer 模式滤波器的图像传感器的示意性分布；

图 4 是可用于图 1 中所示系统的图像处理模块的示意性方框图；

图 5 是来自图 3 中图像传感器的绿色传感单元的绿色图像数据的示意性分布；

图 6 是经过删除一些原始绿色图像数据的可选过程以后图 5 中剩余绿色图像数据的示意性分布；

图 7 是组织为在图 1 的图像处理模块中处理的图 5 中红色、蓝色和绿色图像数据的示意性分布；

图 8 是示出了可用于图 1 中所示系统的图像数据转换技术的流程图；

图 8A 是示出了也可用于图 1 中所示系统的图像数据转换技术的修改的流程图；

图 9 是产生于图 8 中图像转换流程的蓝色图像数据的示意性分布；

图 10 是产生于图 8 中图像转换流程的红色图像数据的示意性分布；

图 11 示出了可应用于图像数据进行伽马校正的示例性可选变换；

图 12 是可用于图 1 中系统以对图像数据进行解压缩和去马赛克的控制程序的流程图；

图 12A 是示出了也可用于图 1 中所示系统的、图 12 中控制程序的修改的流程图；

图 13 是已根据图 12 中流程图解压缩和去马赛克的绿色图像数据的示意性分布；

图 14 是已根据图 12 中流程图解压缩和去马赛克的图 13 中原始绿色图像数据的一半的示意性分布；

图 15 是已根据图 12 中流程图解压缩的蓝色图像数据的示意性分布；以及

图 16 是已根据图 12 中流程图去马赛克的图 15 中蓝色图像数据的示意性分布。

具体实施方式

图 1 是具有图像传感、处理和压缩模块的相机的示意图，描述为用于活动图像的摄像机的情形。这里公开的实施方式描述为这种情形：具有带 Bayer 模式滤波器的单个传感器件的摄像机，因为这些实施方式在这种情形下特别有益。然而，这里的实施方式和发明也可应用于具有其他类型的图像传感器（例如，CMY Bayer 以及其他非 Bayer 模式）的相机、具有其他数目的图像传感器的相机、以不同图像格式类

型操作的相机、和配置为用于静止和/或活动图像的相机。因此，应该理解，这里公开的实施方式是示例性的、而不是限制性的实施方式，因此，这里公开的发明不限于所公开的示例性实施方式。

继续参照图 1，相机 10 可包括机身或者壳体 12，其配置为支撑被配置为探测、处理、和可选择地存储和/或播放视频图像数据的系统 14。例如，系统 14 可包括光学硬件 16、图像传感器 18、图像处理模块 20、压缩模块 22、和存储器件 24。可选择地，相机 10 还可包括监视器模块 26、播放模块 28、和显示器 30。

图 2 示出了相机 10 的一个非限制性的示例性实施方式。如图 2 中所示，光学硬件 16 可通过壳体 12 以使其外表面露出的方式来支撑。在一些实施方式中，系统 14 支撑在壳体 12 中。例如，图像传感器 18、图像处理模块 20、和压缩模块 22 可容置在壳体 12 中。存储器件 24 可安装在壳体 12 中。另外，在一些实施方式中，存储器件 24 可安装在壳体 12 的外部并通过任何类型的已知连接器或者电缆连接至系统 14 的剩余部分。另外，存储器件 24 可用柔性电缆连接至壳体 12，从而允许存储器件 24 在一定程度上独立于壳体 12 移动。例如，通过这种柔性电缆连接，存储器件 24 可戴在使用者的腰带上，允许壳体 12 的总重量减少。进一步，在一些实施方式中，壳体可包括位于其内部和安装到其外部的一个或者多个存储器件 24。另外，壳体 12 也可支撑监视器模块 26、和播放模块 28。另外，在一些实施方式中，显示器 30 可配置为安装在壳体 12 的外部。

光学硬件 16 可以是配置为将进入的图像聚焦至图像传感器 18 的、具有至少一个透镜的透镜系统的形式。光学硬件 16，可选择地，可以是提供有变焦、孔径和聚焦的多透镜系统的形式。另外，光学硬件 16 可以通过壳体 12 支撑并配置为容纳很多不同类型的透镜系统的透镜座的形式，例如，但不限于，光学硬件 16 包括配置为容纳各种尺寸的透镜系统的座，上述透镜系统包括 50-100 毫米 (F2.8) 变焦镜头、18-50 毫米 (F2.8) 变焦镜头、300 毫米 (F2.8) 透镜、15 毫米 (F2.8) 透镜、24 毫米 (F1.9) 透镜、35 毫米 (F1.9) 透镜、50 毫米 (F1.9) 透镜、85 毫米 (F1.9) 透镜、和/或任何其他透镜。如上所述，光学硬

件 16 可配置使得不管附装哪种透镜，图像都可聚焦至图像传感器 18 的光敏面。

图像传感器 18 可以是任何类型的视频传感器件，包括：例如，但不限于，CCD、CMOS、如 Foveon[®]传感器的垂直堆叠的 CMOS 器件、或者用棱镜在传感器之间分光的多传感器阵列。在一些实施方式中，图像传感器 18 可包括具有约 1200 万感光单元的 CMOS 器件。然而，还可使用其他尺寸的传感器。在一些结构中，相机 10 可配置为以“2k”（例如，2048 × 1152 像素）、“4k”（例如，2096 × 2540 像素）、“4.5k”水平分辨率或者更大分辨率输出视频。这里所用，以 xk（例如，上述 2k 和 4k）格式表达的术语中，数量 x 指大致的水平分辨率。照此，“4k”分辨率相当于大约 4000 或者更多水平像素，“2k”相当于大约 2000 或者更多像素。使用现有的商业可用硬件，传感器可以小至约 0.5 英寸（8mm），但是，它也可以是约 1.0 英寸，或者更大。另外，图像传感器 18 可配置为通过选择性输出传感器 18 的仅预定部分来提供变化的分辨率。例如，传感器 18 和/或图像处理模块可配置为允许使用者识别图像数据输出的分辨率。

相机 10 也可配置为下采样并接着处理传感器 18 的输出以产生 2K、1080p、720p、或者任何其他分辨率的视频输出。例如，来自传感器 18 的图像数据可被“窗采样”，从而减小输出图像的尺寸并允许更高的读出速度。但是，也可使用其他尺寸的传感器。另外，相机 10 可配置为对传感器 18 的输出上采样以产生更高分辨率的视频输出。

参照图 1 至 3，在一些实施方式中，传感器 18 可包括 Bayer 模式滤波器。照此，传感器 18，通过它的芯片组（未示出）输出代表了图像传感器 18 的各感光单元探测到的红色、绿色或者蓝色光的幅值的数据。图 3 示意性示出了传感器 18 的 Bayer 模式输出。在一些实施方式中，例如，如图 3 所示，Bayer 模式滤波器具有两倍于红色单元数目和蓝色单元数目的绿色单元。图像传感器 18 的芯片组可用于读取图像传感器的各单元上的电荷，从而以已知的 RGB 格式输出数值流。

接着参照图 4，图像处理模块 20 可选性地配置为以任何已知的方式形成来自图像传感器 18 的数据流的格式。在一些实施方式中，图像

处理模块 20 可配置为将绿色、红色和蓝色图像数据分成三个或者四个单独的数据集。例如，图像处理模块 20 可配置为将红色数据分至一个数据单元，将蓝色数据分至一个蓝色数据单元，以及将绿色数据分至一个绿色数据单元。例如，参照图 4，图像处理模块 20 可包括红色数据处理模块 32、蓝色数据图像处理模块 34 和第一绿色图像数据处理模块 36。

然而，如上所述，图 3 所示 Bayer 模式数据，具有两倍于另外两种颜色的绿色像素。图 5 示出了其中移除了蓝色和红色数据而仅余下原始绿色图像数据的数据单元。

在一些实施方式中，相机 10 可配置为删除或者忽略一些绿色图像数据。例如，在一些实施方式中，图像处理模块 20 可配置为删除 1/2 的绿色图像数据以便绿色图像数据的总数与蓝色和红色图像数据的数量一样。例如，图 6 示出了图像处理模块 20 删除 1/2 的绿色图像数据以后的剩余数据。在图 6 示出的实施方式中，已经删除了行 $n-3$ 、 $n-1$ 、 $n+1$ 和 $n+3$ 。这仅是可被删除的绿色图像数据的格式的一个示例。也可删除其他格式和其他数量的绿色图像数据。

在一些替换方式中，相机 10 可配置为在基于绿色图像数据变换红色和蓝色图像数据以后删除 1/2 的绿色图像数据。这一可选的技术将在描述了从其他颜色图像数据减去绿色图像数据值之后进行描述。

可选地，图像处理模块 20 可配置为选择性地删除绿色图像数据。例如，图像处理模块 20 可包括配置为选择性地确定哪些绿色图像数据被删除的删除分析模块（未示出）。例如，这样的删除模块可配置为确定从绿色图像数据中删除一定格式的行是否会导致混叠假象（例如，莫尔条纹）或者其他视觉上可察觉的假象。删除模块可进一步配置为选择一定格式的绿色图像数据进行删除，使得产生这种假象的风险较小。例如，删除模块可配置为，如果其确定图像传感器 18 捕获的图像包括表现为多个平行水平行的图像特征，则选择交替垂直列的绿色图像数据删除格式。该删除格式可减少或者消除删除平行于图像中探测到的水平行的图像数据的交替行的删除格式可产生的假象，例如，莫尔条纹。

但是，这仅是可被删除模块使用的图像特征和删除格式的类型的一个示例性的、非限制性的例子。删除模块也可配置为探测其他图像特征和使用其他图像数据删除格式，例如，但不限于，交替行、交替对角线、或者其他格式的删除。另外，删除模块可配置为删除其他图像数据（例如，红色和蓝色图像数据）的部分，或者由使用的传感器的类型决定的其他图像数据。

另外，相机 10 可配置为在图像数据中插入数据字段来指示删除了什么图像数据。例如，但不限于，相机 10 可配置为在存储器件 24 中所存储的任何视频剪辑的开头中插入数据字段，来指示在该视频剪辑的每一“帧”删除了什么数据。在一些实施方式中，相机可配置为在通过传感器 18 捕获的每一帧中插入数据字段，来指示删除了什么图像数据。例如，在图像处理模块 20 配置为按一个删除格式来删除 1/2 的绿色图像数据的一些实施方式中，数据字段可以小至一个位的数据字段，来指示是否删除了图像数据。因为图像处理模块 20 配置为仅按一个格式来删除数据，因此一个位足以指示删除了什么数据。

在一些实施方式中，如上所述，图像处理模块 20 可配置为按多于一个的格式来选择性地删除图像数据。这样，图像数据删除字段可以大一些，包括足够数目的值以提供指示是使用了这些不同图像数据删除格式中的哪一个。该数据字段可通过下游组件和或处理来使用以确定剩余图像数据相应于哪些空间位置。

在一些实施方式中，图像处理模块可配置为保留所有的原始绿色图像数据，例如，图 5 所示数据。在这些实施方式中，图像处理模块可包括一个或者多个绿色图像数据处理模块。

如上所述，在已知的 Bayer 模式滤波器中，具有两倍于红色单元数目和蓝色单元数目的绿色单元。换句话说，红色单元包含总 Bayer 模式阵列的 25%，蓝色单元为 Bayer 模式阵列的 25%，绿色单元包含 Bayer 模式阵列单元的 50%。这样，在保留了所有的绿色图像数据的一些实施方式中，图像处理模块 20 可包括第二绿色数据图像处理模块 38。照此，第一绿色数据图像处理模块 36 可处理一半的绿色单元，第二绿色图像数据处理模块 38 可处理剩余的绿色单元。但是，本发明可

与其他类型的模式一起使用，例如，但不限于，CMY 和 RGBW。

图 7 包括由模块 32、34、36 和 38（图 4）处理的红色、蓝色和两个绿色数据分量的示意性示出。这可提供进一步的优点，因为这些模块的每一个的尺寸和配置大致相同，因为他们处理大致相同数目的数据。另外，图像处理模块 20 可选择性地切换于其中处理所有的绿色图像数据（通过使用模块 36 和 38）的模式和其中删除了 1/2 的绿色图像数据的模式（其中仅利用模块 36 和 38 中的一个）之间。但是，也可使用其他配置。

另外，在一些实施方式中，图像处理模块 20 可包括其他模块和/或可配置为执行其他处理，例如，但不限于，伽马校正处理、噪声过滤处理等等。

另外，在一些实施方式中，图像处理模块 20 可配置为从蓝色单元和/或红色单元的值中减去绿色单元的值。照此，在一些实施方式中，当通过图像传感器 18 探测到某些颜色时，相应的红色或者蓝色单元可减少至零。例如，在很多摄影中，存在大面积的黑色、白色、或者灰色、或者从灰色过渡到红色或者蓝色的颜色。这样，如果图像传感器 18 的相应像素感测到一块灰色，绿色、红色和蓝色的幅值将大致相等。这样，如果从红色和蓝色值中减去绿色值，红色和蓝色值将降至零或者接近零。这样，在随后的压缩处理中，感测黑色、白色或者灰色块的像素中将产生更多的零，从而产生的数据将具有更大的可压缩性。另外，由于其他原因，从其他颜色中的一个或者两者中减去绿色可使产生的图像数据更具可压缩性。

这种技术，由于其与原始图像数据的熵之间的关系，有助于实现更高效率的压缩率且仍保持视觉上无损。例如，图像的熵跟图像中随机的量有关。例如，从其他颜色的图像数据中减去一种颜色的图像数据可减少随机，从而减少这些颜色的图像数据的熵，因而允许数据以更高的压缩率和更少损失被压缩。典型地，图像不是随机颜色值的集合。所以，这种减去技术可使用单元的相关性来实现更好的压缩。压缩量将至少部分地取决于图像中原始信息的熵。

在一些实施方式中，从红色或者蓝色像素中减去的量值可以是

与被减红色或者蓝色像素相邻的绿色像素输出的值的量值。进一步，在一些实施方式中，从红色或者蓝色单元中减去的绿色量值可以从周围绿色单元的平均值中得出。这种技术更详细地描述如下。但是，也可使用其他技术。

可选地，图像处理模块 20 也可配置为从其他颜色中选择性地减去绿色图像数据。例如，图像处理模块 20 可配置为确定从其他颜色中任一个的图像数据的一部分中减去绿色图像数据是否会提供更好的压缩性。在这种模式中，图像处理模块 20 可配置为在图像数据中插入标记来指示修改了图像数据的什么部分（例如通过减去绿色图像数据修改）和没有修改哪部分。通过这些标记，下游去马赛克/重构组件可基于这些数据标记的状态将绿色图像值选择性地加回其他颜色的图像数据中。

可选地，图像处理模块 20 还可包括配置为对红色和蓝色数据舍入（rounding）的另外的数据缩减模块（未示出）。例如，如果在减去绿色幅值以后红色或者蓝色数据接近零（例如，对范围为 0-255 的 8 位数值范围来说在 1 或者 2 以内，或者，对更高分辨率系统来说更高的幅值）。例如，传感器 18 可以为以数值范围 0-4095 来输出红色、蓝色和绿色数据的 12 位传感器。舍入模块对数据执行的任何舍入或者滤波可以调整以达成期望的效果。例如，如果期望无损输出，则以较小程度执行舍入；而如果可接受一些损失或者损失性输出，则以较大的程度执行。可以执行一些舍入且仍产生视觉上无损的输出。例如，按 8-位的数值范围，具有上至 2 或者 3 的绝对值的红色或者蓝色数据可舍入为 0 且仍提供视觉上无损的输出。另外，按 12-位的数值范围，具有上至 10 至 20 的绝对值的红色或者蓝色数据可舍入为 0 且仍提供视觉上无损的输出。

另外，可舍入为零或舍入为其他值、且仍提供视觉上无损的输出的值的量值取决于系统的配置，包括光学硬件 16、图像传感器 18、图像传感器的分辨率、图像传感器 18 的颜色分辨率（位）、滤波器的类型、图像处理模块 20 执行的抗混叠技术或者其他技术、压缩模块 22 执行的压缩技术、和/或相机 10 的其他参数或者特征。

如上所述，在一些实施方式中，相机 10 可配置为在基于绿色图像数据变换红色和蓝色图像数据以后，删除 1/2 的绿色图像数据。例如，但不限于，处理模块 20 可配置为在从红色和蓝色数据值中减去周围绿色数据值的量值的平均值以后，删除 1/2 的绿色图像数据。绿色数据中的这种缩减可减少对相关硬件的吞吐量需求。另外，剩余的绿色图像数据可用于重构红色和蓝色图像数据，下面将参照图 14 和 16 更详细地说明。

如上所述，相机 10 还可包括压缩模块 22。压缩模块 22 可以是单个芯片的形式或者可通过软件和另外的处理器实现。例如，压缩模块 22 可以是商业上可用的压缩芯片的形式，其根据 JPEG 2000 标准执行压缩技术，或者其他压缩技术。

压缩模块可配置为对来自图像处理模块 20 的数据执行任何类型的压缩处理。在一些实施方式中，压缩模块 22 执行利用图像处理模块 20 执行的技术的压缩技术。例如，如上所述，图像处理模块 20 可配置为通过减去绿色图像数据的量值来减小红色和蓝色数据的值的量值，从而产生更多的零值，以及其他效果。另外，图像处理模块 20 可执行使用图像数据的熵的对原始数据的操作。这样，压缩模块 22 执行的压缩技术可为这样的类型：其受益于更大串的零的出现来减小所输出的压缩数据的大小。

进一步，压缩模块 22 可配置为压缩来自图像处理模块 20 的图像数据以产生视觉上无损的输出。例如，首先，压缩模块可配置为应用任何已知的压缩技术，例如，但不限于，JPEG 2000、活动 JPEG (MotionJPEG)、任何基于 DCT 的编解码器、任何设计用于压缩 RGB 图像数据的编解码器、H.264、MPEG4、霍夫曼或者其他技术。

根据使用的压缩技术的类型，压缩技术的各种参数可设定为提供视觉上无损的输出。例如，上述很多压缩技术可调整为不同的压缩率，其中当解压时，产生的图像对低压缩率来说质量较好，而对高压缩率来说质量较低。这样，压缩模块可配置为以提供视觉上无损的输出的方式压缩图像数据，或者可配置为允许使用者调整各种参数以获得视觉上无损的输出。例如，压缩模块 22 可配置为以大约 6:1、7:1、8:1

或者更大的压缩率来压缩图像数据。在一些实施方式中，压缩模块 22 可配置为将图像数据压缩为 12:1 的比率或者更高。

另外，压缩模块 22 可配置为允许使用者调整通过压缩模块 22 实现的压缩率。例如，相机 10 可包括用户界面，其允许使用者输入使压缩模块 22 改变压缩率的命令。这样，在一些实施方式中，相机 10 可提供可变的压缩。

这里所用的术语“视觉上无损”意图包括这样的输出：当在同样的显示器件上与原始（从未压缩过）图像数据并排比较时，仅仅基于对图像的目测，本领域普通技术人员会无法确定哪幅图像是具有合理精确度的原始图像。

继续参照图 1，相机 10 还可包括存储器件 24。存储器件可以是任何类型的数字存储的形式，例如，但不限于，硬盘、闪存或者任何其他类型的存储器件。在一些实施方式中，存储器件 24 的尺寸足够大以存储来自压缩模块 22 的图像数据，对应于 12 兆像素分辨率、12-位颜色分辨率和 60 帧每秒的至少大约 30 分钟视频。但是，存储器件 24 可以具有任何尺寸。

在一些实施方式中，存储器件 24 可安装在壳体 12 的外部。进一步，在一些实施方式中，存储器件 24 可通过标准通信端口连接至系统 14 的其他部件，上述端口包括，例如，但不限于，IEEE 1394、USB 2.0、IDE、SATA 等等。进一步，在一些实施方式中，存储器件 24 可包含根据 RAID 协议操作的多个硬驱动。但是，可使用任何类型的存储器件。

继续参照图 1，如上所述，在一些实施方式中，系统可包括监视器模块 26 和显示器件 30，配置为允许使用者在操作期间观看通过图像传感器 18 捕获的视频图像。在一些实施方式中，图像处理模块 20 可包括配置为将缩减分辨率的图像数据输出至监视器模块 26 的二次抽样系统。例如，这种二次抽样系统可配置为输出视频图像数据以支持 2K、1080p、720p 或者任何其他分辨率。在一些实施方式中，用于去马赛克的滤波器还可适于执行下采样滤波，以便下采样和滤波可以同时执行。监视器模块 26 可配置为对来自图像处理模块 20 的数据执

行任何类型的去马赛克处理。其后，监视器模块 26 可输出去马赛克的图像数据至显示器 30。

显示器 30 可以是任何类型的监视器件。例如，但不限于，显示器 30 可以通过壳体 12 支撑的 4 英寸 LCD 面板。例如，在一些实施方式中，显示器 30 可以连接于无限量调整，其配置为允许显示器 30 相对于壳体 12 调整为任何位置，以便使用者可相对于壳体 12 以任何角度观看显示器 30。在一些实施方式中，显示器 30 可通过任何类型的视频电缆，例如，RGB 或者 YCC 格式视频电缆，连接至监视器模块。

可选地，播放模块 28 可配置为接收来自存储器件 24 的数据，对图像数据进行解压和去马赛克，然后输出图像数据至显示器 30。在一些实施方式中，监视器模块 26 和播放模块 28 可通过中间显示控制器（未示出）连接至显示器。照此，显示器 30 可通过单个连接器连接至显示控制器。显示控制器可配置为从监视器模块 26 或者播放模块 28 传输数据至显示器 30。

图 8 包括示出了相机 10 对图像数据的处理的流程图 50。在一些实施方式中，流程图 50 可表示存储在存储器件（例如，存储器件 24 或者相机 10 中另外的存储器件（未示出））中的控制流程。另外，中央处理器（CPU）（未示出）可配置为执行该控制流程。下面对相应于在处理视频图像数据的单个帧的情况下描述的流程图 50 的方法进行介绍。这样，这种技术可应用于对单个静止图像的处理。这些流程还可应用于对连续视频的处理，例如，大于 12 的帧频，以及 20、23.976、24、30、60 和 120 的帧频，或者介于这些帧频之间或者更大的其他帧频。

继续参照图 8，控制流程可开始于操作块 52。在操作块 52 中，相机 10 可获得传感器数据。例如，参照图 1，可包括 Bayer 传感器和芯片组的图像传感器 18 可输出图像数据。

例如，但不限于，参照图 3，图像传感器可包含在其光接收面具有 Bayer 模式滤波器的 CMOS 器件。这样，来自光学硬件 16 的聚焦图像聚焦至图像传感器 18 的 CMOS 器件上的 Bayer 模式滤波器。图 3 示出了通过在 CMOS 器件上布置 Bayer 模式滤波器所产生的 Bayer 模

式的一个例子。

在图 3 中，列 m 是从 Bayer 模式的左边缘起第四列，而行 n 是从该格式的上边缘起第四行。其余的行和列相对于列 m 和行 n 来标记。但是，这种布局仅是为了示意性目的随机选出，并不限制这里公开的任何实施方式和发明。

如上所述，已知的 Bayer 模式滤波器通常包括两倍于蓝色和红色单元的绿色单元。在图 5 的模式中，蓝色单元仅出现在行 $n-3$ 、 $n-1$ 、 $n+1$ 和 $n+3$ 中。红色单元仅出现在行 $n-2$ 、 n 、 $n+2$ 和 $n+4$ 中。但是，绿色单元出现在所有的行和列中，其间散布着红色和蓝色单元。

因此，在操作块 52 中，从图像传感器 18 输出的红色、蓝色和绿色图像数据可由图像处理模块 20 接收，并组织为分离的颜色的数据分量中，例如，那些图 7 中示出的。如图 7 所示，如上参照图 4 所述，图像处理模块 20 可将红色、蓝色和绿色图像数据分成四个分离的分量。图 7 示出了两个绿色分量（绿色 1 和绿色 2）、一个蓝色分量和一个红色分量。但是，这仅是处理来自图像传感器 18 的图像数据的一个示例性方法。另外，如上所述，可选地，图像处理模块 20 可随机或者选择性地删除 1/2 的绿色图像数据。

在操作块 52 之后，流程图 50 可前进至操作块 54。在操作块 56 中，可进一步处理图像数据。例如，可选地，可进一步处理所产生数据中的任一个或者全部（例如，绿色 1、绿色 2、来自图 9 的蓝色图像数据和来自图 10 的红色图像数据）。

例如，可以其他方式预加重或者处理图像数据。在一些实施方式中，图像数据可被处理得更加（数学上）非线性。一些压缩算法受益于执行这种压缩前对单元的线性化。但是，还可使用其他技术。例如，图像数据可用线性曲线处理，其基本不提供加重。

在一些实施方式中，操作块 54 可使用由函数 $y = x^{0.5}$ 定义的曲线来处理图像数据。在一些实施方式中，该曲线可在图像数据为，例如但不限于，标准化为 0-1 范围的浮点数据时使用。在其他实施方式中，例如，当图像数据为 12-位数据时，可使用曲线 $y = (x/4095)^{0.5}$ 来处理图像。另外，可使用其他曲线来处理图像数据，例如 $y = (x+c)^g$ ，其中

$0.01 < g < 1$ 且 c 为偏移量, c 在一些实施方式中可以为 0。另外, 还可使用对数曲线。例如, 形式为 $y = A * \log(B * x + C)$ 的曲线, 其中, A 、 B 和 C 是为提供期望的结果所选择的常量。另外, 可修改上述曲线和方法以在黑色附近提供更加线性的区域, 类似于在众所周知的 Rec709 伽马校正中使用的那些技术。在将这些处理应用于图像数据时, 可将同样的处理应用于所有的图像数据, 或者, 可将不同的处理应用于不同颜色的图像数据。但是, 这些仅是可用于处理图像数据的示例性曲线, 还可使用其它曲线或者变换。另外, 可使用例如上述那些的数学函数、或者查找表 (LUTs) 来应用这些处理技术。另外, 不同的处理、技术或者变换可用于不同类型的图像数据、记录图像数据中使用的不同 ISO 设定、温度 (其可影响噪声水平) 等等。

在操作块 54 之后, 流程图 50 可前进至操作块 56。在操作块 56 中, 可变换红色和蓝色单元。例如, 如上所述, 可从蓝色和红色图像数据分量中的每一个中减去绿色图像数据。在一些实施方式中, 红色或者蓝色图像数据值可通过减去邻近红色或者蓝色单元的至少一个绿色单元的图像数据值来变换。在一些实施方式中, 可从红色或者蓝色图像数据值中减去多个相邻绿色单元的数据值的平均值。例如, 但不限于, 可计算 2、3、4 或者更多个绿色图像数据值的平均值, 并将其从绿色单元附近的红色或者蓝色单元中减去。

例如, 但不限于, 参照图 3, 红色单元 $R_{m-2,n-2}$ 的原始输出被四个绿色单元 $G_{m-2,n-3}$ 、 $G_{m-1,n-2}$ 、 $G_{m-3,n-2}$ 和 $G_{m-2,n-1}$ 围绕。这样, 红色单元 $R_{m-2,n-2}$ 可如下通过减去周围绿色单元的值的平均值来变换:

$$(1) \quad R_{m,n} = R_{m,n} - (G_{m,n-1} + G_{m+1,n} + G_{m,n+1} + G_{m-1,n}) / 4$$

类似地, 蓝色单元可如下通过减去周围绿色单元的平均值的类似方式来变换:

$$(2) \quad B_{m+1,n+1} = B_{m+1,n+1} - (G_{m+1,n} + G_{m+2,n+1} + G_{m+1,n+2} + G_{m,n+1}) / 4$$

图 9 示出了其中原始蓝色原始数据 $B_{m-1,n-1}$ 变换后所产生的蓝色数据分量, 新值标记为 $B'_{m-1,n-1}$ (仅填充该分量中的一个值, 且同样的技术可用于所有的蓝色单元)。类似地, 图 10 示出了已经变换的红色数据分量, 其中, 变换了的红色单元 $R_{m-2,n-2}$ 标记为 $R'_{m-2,n-2}$ 。在这种状态下,

图像数据仍被认为是“原始”数据。例如，对数据实施的数学处理完全可逆，以便可通过逆反那些流程来获得所有的原始值。

继续参照图 8，操作块 56 之后，流程图 50 可前进至操作块 58。在操作块 58 中，产生的数据（其是原始的或者基本上原始）可使用任何已知的压缩算法来进一步压缩。例如，压缩模块 22（图 1）可配置为执行这样的压缩算法。压缩之后，压缩的原始数据可存储在存储器件 24（图 1）中。

图 8A 示出了流程图 50 的一个修改，以参考数值 50' 来标记。上述参照流程图 50 的一些步骤，可与流程图 50' 的一些相应步骤类似或者相同，因而以相同的参考数值来标记。

如图 8A 所示，在一些实施方式中，流程图 50' 可选地忽略操作块 54。在一些实施方式中，流程图 50' 还可包括操作块 57，其中可对图像数据应用查找表。例如，可选的查找表，如图 11 的曲线所表示的，可用于提高进一步的压缩。在一些实施方式中，图 11 的查找表仅仅用于绿色单元。在其他实施方式中，查找表还可用于红色和蓝色单元。相同的查找表可用于这三个不同的颜色，或者每个颜色可具有自己的查找表。另外，还可应用除了图 11 的曲线所体现的之外的。

通过上述参照图 8 和 8A 所述的方式来处理图像数据，已发现，来自图像传感器 18 的图像数据可按 6:1 或者更大的压缩率来压缩且仍保持视觉上无损。另外，尽管对图像数据进行了变换（例如，绿色图像数据的减去），但所有的原始图像数据对于终端使用者仍然可得。例如，通过逆反某些过程，可提取所有的或者基本上所有的原始数据，并使用使用者期望的任何方法进一步处理、滤波和/或去马赛克。

例如，参照图 12，可对存储在存储器件 24 中的数据进行解压和去马赛克。可选地，相机 10 可配置为执行流程图 60 示出的方法。例如，但不限于，播放模块 28 可配置为执行流程图 60 示出的方法。但是，使用者还可将数据从存储器件 24 传输至分离的工作站，并应用流程图 60 中的任何或者全部步骤和/或操作。

继续参照图 12，流程图 60 可开始于操作块 62，其中对来自存储器件 24 的数据进行解压。例如，操作块 62 中对数据的解压可以是操

作块 58 (图 8) 中执行的压缩算法的逆向。操作块 62 之后, 流程图 60 可前进至操作块 64。

在操作块 64 中, 可逆反操作块 56 (图 8) 中执行的方法。例如, 可将图 11 的曲线的逆向或者上述参照图 8 和 8A 中的操作块 56 所述的任何其他函数的逆应用于图像数据。操作块 64 之后, 流程图 60 可前进至步骤 66。

在操作块 66 中, 可对绿色单元进行去马赛克。例如, 如上所述, 来自数据分量绿色 1 和/或绿色 2 (图 7) 的所有值可存储在存储器件 24 中。例如, 参照图 5, 来自数据分量绿色 1、绿色 2 的绿色图像数据可按照图像传感器 18 中应用的原始 Bayer 模式来布置。然后, 绿色数据可通过任何已知的技术进一步去马赛克, 例如, 线性插值、双线性等等。

图 13 示出了对所有的原始绿色图像数据去马赛克后的绿色图像数据的示例性布局。以字母 G_x 标记的绿色图像单元代表了原始 (解压的) 图像数据, 而标记为 DG_x 的单元代表了通过去马赛克处理从原始数据得出的单元。该术语用于下述对其它颜色的去马赛克过程。图 14 示出了对 $1/2$ 的原始绿色图像数据去马赛克后的绿色图像数据的示例性图像数据布局。

继续参照图 12, 流程图 60 可在操作块 66 之后前进至操作块 68。在操作块 68 中, 可进一步处理去马赛克后的绿色图像数据。例如, 但不限于, 噪声去除技术可应用于绿色图像数据。但是, 任何其他图像处理技术, 例如, 抗混叠技术, 也可应用于绿色图像数据。操作块 68 之后, 流程图 60 可前进至操作块 70。

在操作块 70 中, 可对红色和蓝色图像数据进行去马赛克。例如, 首先, 图 9 的蓝色图像数据可根据原始 Bayer 模式 (图 15) 重新布置。周围单元, 如图 16 所示, 可使用任何已知的去马赛克技术, 包括线性插值、双线性等等, 来从现有的蓝色图像数据进行去马赛克。作为去马赛克步骤的结果, 对于每个像素将有蓝色图像数据, 如图 16 所示。但是, 基于图 9 的修改的蓝色图像数据, 即, 从其中减去了绿色图像数据值的蓝色图像数据值, 对该蓝色图像数据进行去马赛克。

操作块 70 还可包括对红色图像数据的去马赛克过程。例如，来自图 10 的红色图像数据可按照原始 Bayer 模式重新布置，并通过任何已知的去马赛克方法，例如线性插值、双线性等等，进一步去马赛克。

操作块 70 之后，流程图可前进至操作块 72。在操作块 72 中，可根据去马赛克的绿色图像数据重构去马赛克的红色和蓝色图像数据。

在一些实施方式中，红色和蓝色图像数据单元的每一个都可通过加上来自同位置处的绿色图像单元（与列“m”和行“n”相同位置的绿色图像单元）的绿色值来重构。例如，去马赛克以后，蓝色图像数据包括蓝色单元值 $DB_{m-2,n-2}$ 。因为图 3 的原始 Bayer 模式在该位置并不包括蓝色单元，因此该蓝色值 $DB_{m-2,n-2}$ 是基于例如来自单元 $B_{m-3,n-3}$ 、 $B_{m-1,n-3}$ 、 $B_{m-3,n-1}$ 和 $B_{m-1,n-1}$ 或者任何其他技术或者其他蓝色图像单元中的蓝色值、通过上述去马赛克过程导出的。如上所示，这些值在操作块（图 8）中被修改，因而并不相应于图像传感器 18 探测到的原始蓝色图像数据。更确切地，从这些值中的每一个中已减去平均绿色值。这样，产生的蓝色图像数据 $DB_{m-2,n-2}$ 还代表了已减去了绿色图像数据的蓝色数据。这样，在一个实施方式中，单元 $DG_{m-2,n-2}$ 的去马赛克的绿色图像数据可加到蓝色图像值 $DB_{m-2,n-2}$ 中，从而产生重构的蓝色图像数据值。

在一些实施方式中，可选地，蓝色和/或红色图像数据可在去马赛克之前首先重构。例如，变换的蓝色图像数据 $B'_{m-1,n-1}$ 可首先通过加上周围绿色单元的平均值来重构。这将导致获得或者重新计算原始蓝色图像数据 $B_{m-1,n-1}$ 。该过程可对所有的蓝色图像数据执行。接着，蓝色图像数据可通过任何已知的去马赛克技术进一步去马赛克。红色图像数据也可按相同的或者类似的方式处理。

图 12A 示出了流程图 60 的修改，以参考数值 60' 来标记。上述参照流程图 60 的一些步骤，与流程图 60' 的一些相应步骤类似或者相同，因而以相同的参考数值来标记。

如图 12A 所示，流程图 60' 可包括操作块 62 之后的操作块 68'。在操作块 68' 中，可对图像数据执行噪声去除技术。例如，但不限于，噪声去除技术可应用于绿色图像数据。但是，任何其他图像处理技术，例如抗混叠技术，也可应用于绿色图像数据。操作块 68' 之后，流程图

可前进至操作块 70'。

在操作块 70' 中，可对图像数据进行去马赛克。如上参照操作块 66 和 70 所述，绿色、红色和蓝色图像数据可按两步进行去马赛克。但是，在当前流程图 60' 中，所有三个颜色的图像数据的去马赛克体现在单个步骤中，尽管上述相同的去马赛克技术可应用于此去马赛克过程。操作块 70' 之后，流程图可前进至操作块 72 和操作快 64，操作块 72 中可重构红色和蓝色图像数据，操作块 64 中可应用逆向查找表。

在根据流程图 70 或者 70' 中的任一个或者任何其他合适的方法对图像数据解压和处理以后，图像数据可进一步处理为去马赛克的图像数据。

通过在重构红色和蓝色图像数据之前对绿色图像数据进行去马赛克，可实现某些进一步的优点。例如，如上所述，人眼对绿色光更加敏感。对绿色图像数据的去马赛克和处理优化了人眼更加敏感的绿色图像值。这样，随后对红色和蓝色图像数据的重构将受到对绿色图像数据的处理的影响。

另外，Bayer 模式具有两倍于红色和蓝色单元的绿色单元。这样，在保留了所有绿色数据的实施方式中，与红色或者蓝色图像数据分量相比，绿色单元拥有两倍的图像数据。这样，去马赛克技术、滤波器和其他图像处理技术将产生更好的去马赛克、锐化或者另外的滤波的图像。使用这些去马赛克的值来对红色和蓝色图像数据进行重建和去马赛克将与更高分辨率的原始绿色数据相关的益处传至红色和蓝色单元的处理、重建和去马赛克。照此，产生的图像进一步得到增强。



图 1



图 2

	$m-3$	$m-2$	$m-1$	m	$m+1$	$m+2$	$m+3$	$m+4$
$n-3$	$B_{m-3,n-3}$	$G_{m-2,n-3}$	$B_{m-1,n-3}$	$G_{m,n-3}$	$B_{m+1,n-3}$	$G_{m+2,n-3}$	$B_{m+3,n-3}$	$G_{m+4,n-3}$
$n-2$	$G_{m-3,n-2}$	$R_{m-2,n-2}$	$G_{m-1,n-2}$	$R_{m,n-2}$	$G_{m+1,n-2}$	$R_{m+2,n-2}$	$G_{m+3,n-2}$	$R_{m+4,n-2}$
$n-1$	$B_{m-3,n-1}$	$G_{m-2,n-1}$	$B_{m-1,n-1}$	$G_{m,n-1}$	$B_{m+1,n-1}$	$G_{m+2,n-1}$	$B_{m+3,n-1}$	$G_{m+4,n-1}$
n	$G_{m-3,n}$	$R_{m-2,n}$	$G_{m-1,n}$	$R_{m,n}$	$G_{m+1,n}$	$R_{m+2,n}$	$G_{m+3,n}$	$R_{m+4,n}$
$n+1$	$B_{m-3,n+1}$	$G_{m-2,n+1}$	$B_{m-1,n+1}$	$G_{m,n+1}$	$B_{m+1,n+1}$	$G_{m+2,n+1}$	$B_{m+3,n+1}$	$G_{m+4,n+1}$
$n+2$	$G_{m-3,n+2}$	$R_{m-2,n+2}$	$G_{m-1,n+2}$	$R_{m,n+2}$	$G_{m+1,n+2}$	$R_{m+2,n+2}$	$G_{m+3,n+2}$	$R_{m+4,n+2}$
$n+3$	$B_{m-3,n+3}$	$G_{m-2,n+3}$	$B_{m-1,n+3}$	$G_{m,n+3}$	$B_{m+1,n+3}$	$G_{m+2,n+3}$	$B_{m+3,n+3}$	$G_{m+4,n+3}$
$n+4$	$G_{m-3,n+4}$	$R_{m-2,n+4}$	$G_{m-1,n+4}$	$R_{m,n+4}$	$G_{m+1,n+4}$	$R_{m+2,n+4}$	$G_{m+3,n+4}$	$R_{m+4,n+4}$

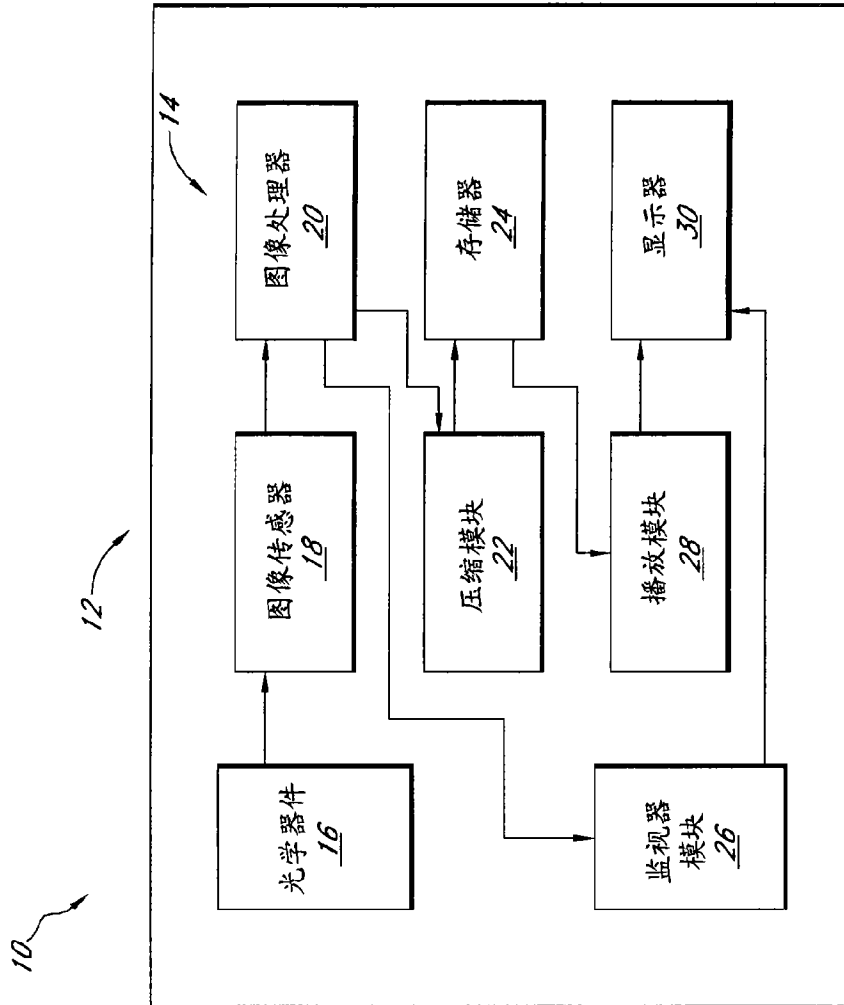
图 3

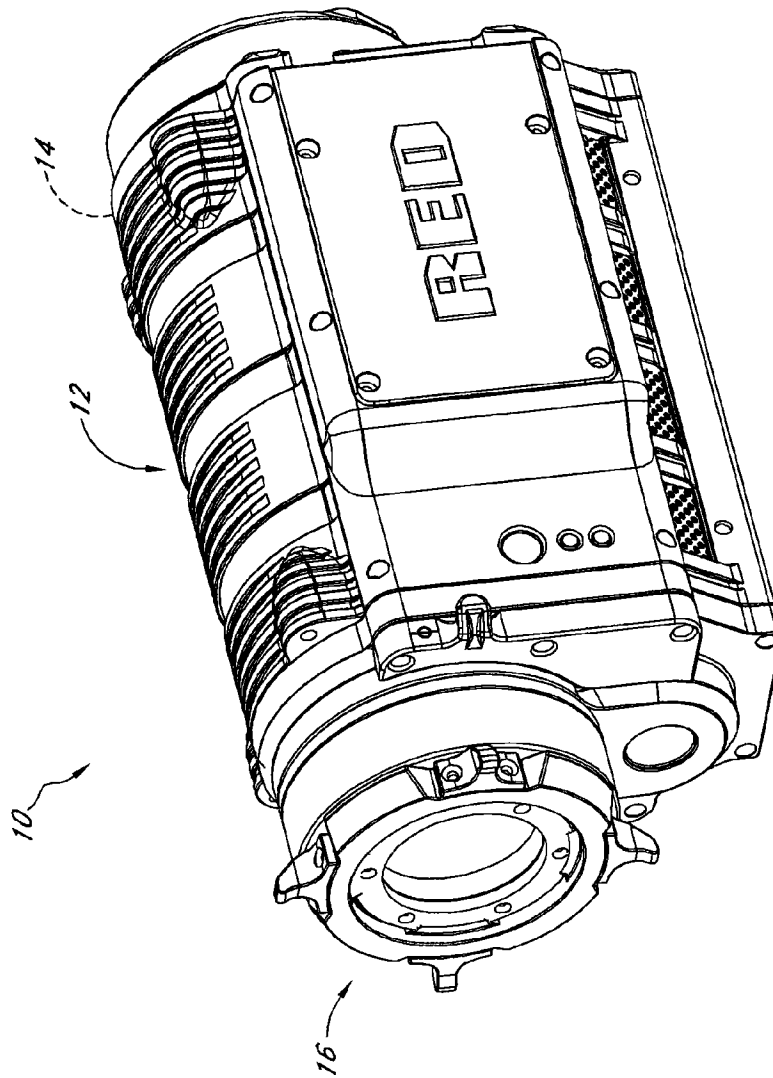

图 4

	$m-3$	$m-2$	$m-1$	m	$m+1$	$m+2$	$m+3$	$m+4$
$n-3$		$G_{m-2,n-3}$		$G_{m,n-3}$		$G_{m+2,n-3}$		$G_{m+4,n-3}$
$n-2$	$G_{m-3,n-2}$		$G_{m-1,n-2}$		$G_{m+1,n-2}$		$G_{m+3,n-2}$	
$n-1$		$G_{m-2,n-1}$		$G_{m,n-1}$		$G_{m+2,n-1}$		$G_{m+4,n-1}$
n	$G_{m-3,n}$		$G_{m-1,n}$		$G_{m+1,n}$		$G_{m+3,n}$	
$n+1$		$G_{m-2,n+1}$		$G_{m,n+1}$		$G_{m+2,n+1}$		$G_{m+4,n+1}$
$n+2$	$G_{m-3,n+2}$		$G_{m-1,n+2}$		$G_{m+1,n+2}$		$G_{m+3,n+2}$	
$n+3$		$G_{m-2,n+3}$		$G_{m,n+3}$		$G_{m+2,n+3}$		$G_{m+4,n+3}$
$n+4$	$G_{m-3,n+4}$		$G_{m-1,n+4}$		$G_{m+1,n+4}$		$G_{m+3,n+4}$	

图 5

	$m-3$	$m-2$	$m-1$	m	$m+1$	$m+2$	$m+3$	$m+4$
$n-3$								
$n-2$	$G_{m-3,n-2}$		$G_{m-1,n-2}$		$G_{m+1,n-2}$		$G_{m+3,n-2}$	
$n-1$								
n	$G_{m-3,n}$		$G_{m-1,n}$		$G_{m+1,n}$		$G_{m+3,n}$	
$n+1$								
$n+2$	$G_{m-3,n+2}$		$G_{m-1,n+2}$		$G_{m+1,n+2}$		$G_{m+3,n+2}$	
$n+3$								
$n+4$	$G_{m-3,n+4}$		$G_{m-1,n+4}$		$G_{m+1,n+4}$		$G_{m+3,n+4}$	

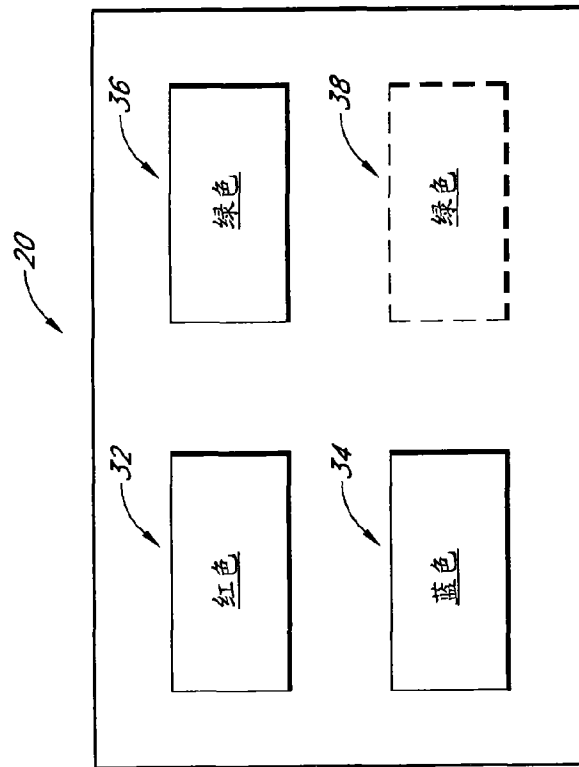
图 6

$C_{m-3,n-2}$	$C_{m-1,n-2}$	$C_{m+1,n-2}$	$C_{m+3,n-2}$
$C_{m-3,n}$	$C_{m-1,n}$	$C_{m+l,n}$	$C_{m+3,n}$
$C_{m-3,n+2}$	$C_{m-1,n+2}$	$C_{m+1,n+2}$	$C_{m+3,n+2}$
$C_{m-3,n++}$	$C_{m-1,n++}$	$C_{m+l,n++}$	$C_{m+3,n++}$

绿色2

$R_{m-2,n-2}$	$R_{m,n-2}$	$R_{m+2,n-2}$	$R_{m+4,n-2}$
$R_{m-2,n}$	$R_{m,n}$	$R_{m+2,n}$	$R_{m+4,n}$
$R_{m-2,n+2}$	$R_{m,n+2}$	$R_{m+2,n+2}$	$R_{m+4,n+2}$
$R_{m-2,n++}$	$R_{m,n++}$	$R_{m+2,n++}$	$R_{m+4,n++}$

红色

$C_{m-2,n-3}$	$C_{m,n-3}$	$C_{m+2,n-3}$	$C_{m+4,n-3}$
$C_{m-2,n-l}$	$C_{m,n-l}$	$C_{m+2,n-l}$	$C_{m+4,n-l}$
$C_{m-2,n+1}$	$C_{m,n+1}$	$C_{m+2,n+1}$	$C_{m+4,n+1}$
$C_{m-2,n+3}$	$C_{m,n+3}$	$C_{m+2,n+3}$	$C_{m+4,n+3}$

绿色1

$B_{m-3,n-3}$	$B_{m-1,n-3}$	$B_{m+1,n-3}$	$B_{m+3,n-3}$
$B_{m-3,n-l}$	$B_{m-1,n-l}$	$B_{m+1,n-l}$	$B_{m+3,n-l}$
$B_{m-3,n+1}$	$B_{m-1,n+1}$	$B_{m+1,n+1}$	$B_{m+3,n+1}$
$B_{m-3,n+3}$	$B_{m-1,n+3}$	$B_{m+1,n+3}$	$B_{m+3,n+3}$

蓝色

图 7



图 8



图 8A

	$B_{m-1, n-1}^2 = \frac{B_{m-1, n-1}^2 + (G_{m-1, n-2} + G_{m, n-1} + G_{m-1, n} + G_{m-2, n-1})^2}{4}$		

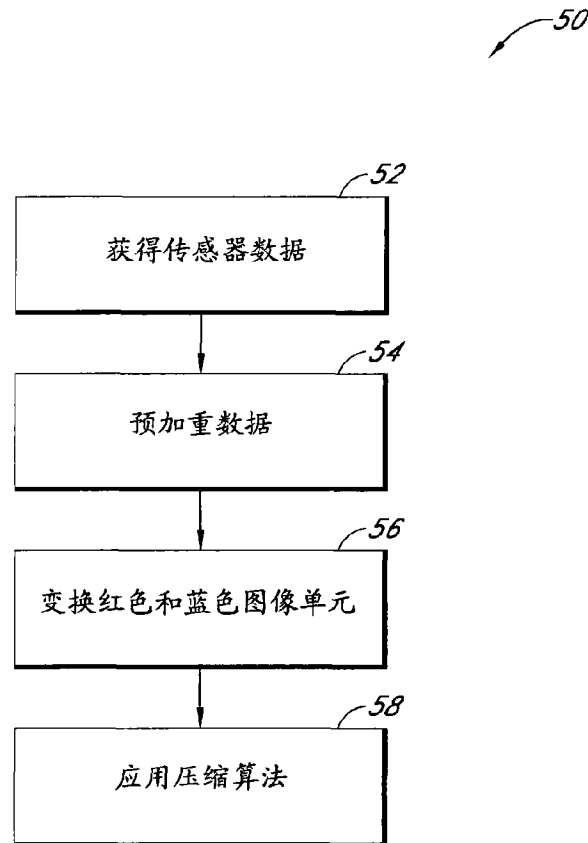
图 9

	$\begin{aligned} R_{m-2, n-2}^1 &= \\ R_{m-2, n-2} &= \\ (G_{m-2, n-3} + G_{m-1, n-2} + \\ G_{m-2, n-1} + G_{m-3, n-2})/4 \end{aligned}$		

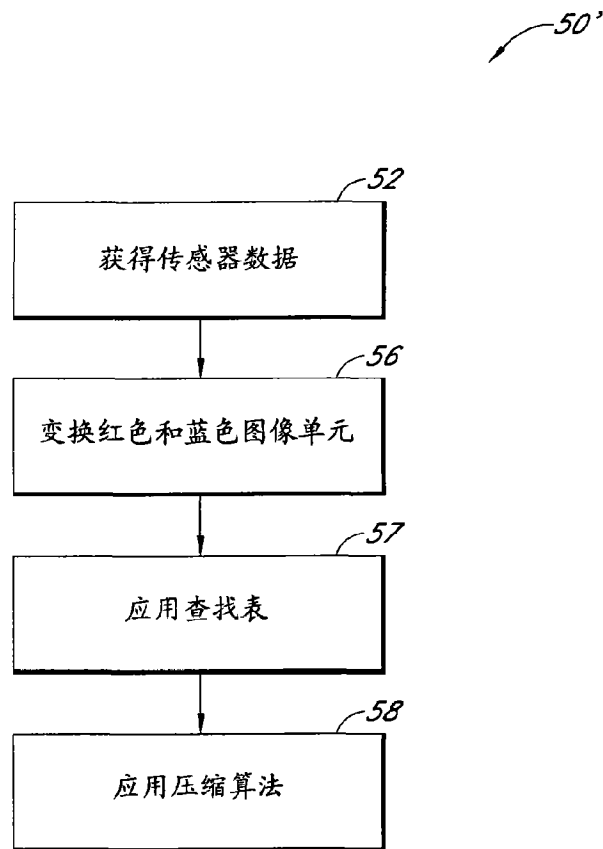
图 10



图 11



图 12

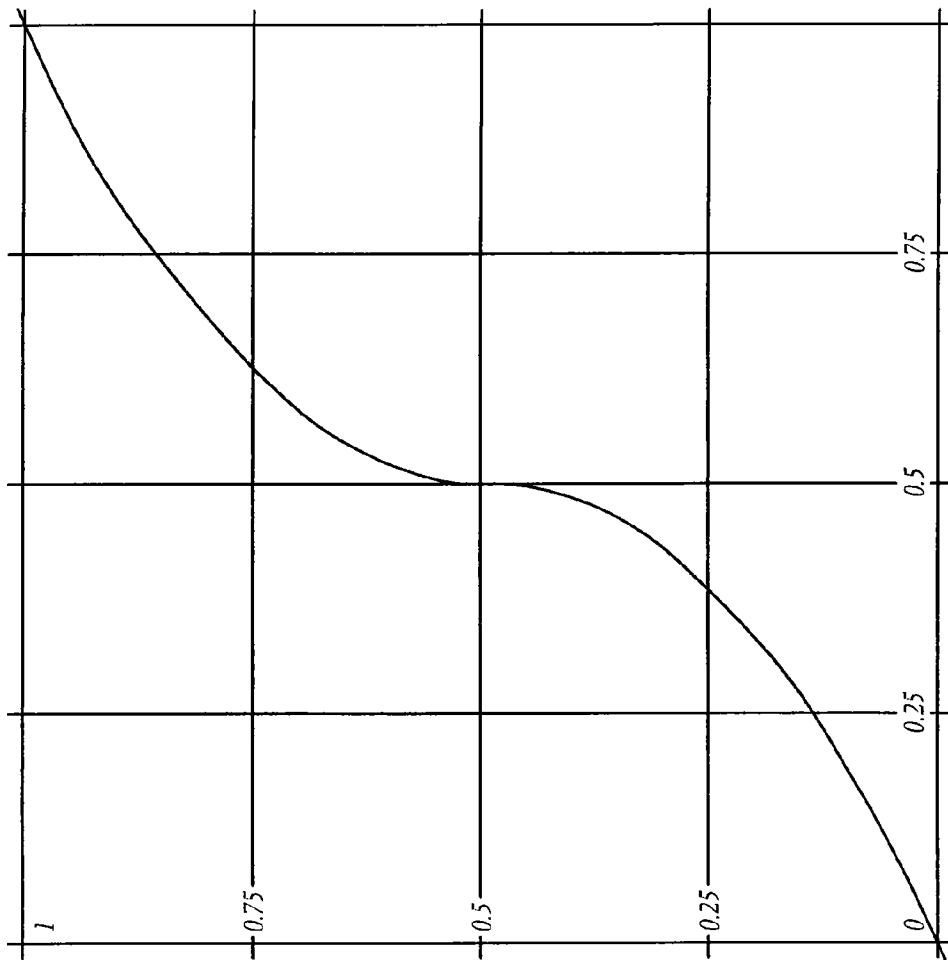

图 12A

$n-3$	$m-3$	$m-2$	$m-1$	m	$m+1$	$m+2$	$m+3$	$m+4$
$n-3$	$DG_{m-3,n+3}$	$G_{m-2,n+3}$	$DG_{m-1,n+3}$	$G_{m,n+3}$	$DG_{m+1,n+3}$	$G_{m+2,n+3}$	$DG_{m+3,n+3}$	$G_{m+4,n+3}$
$n-2$	$G_{m-3,n+2}$	$DG_{m-2,n+2}$	$G_{m-1,n+2}$	$DG_{m,n+2}$	$G_{m+1,n+2}$	$DG_{m+2,n+2}$	$G_{m+3,n+2}$	$DG_{m+4,n+2}$
$n-1$	$DG_{m-3,n+1}$	$G_{m-2,n+1}$	$DG_{m-1,n+1}$	$G_{m,n+1}$	$DG_{m+1,n+1}$	$G_{m+2,n+1}$	$DG_{m+3,n+1}$	$G_{m+4,n+1}$
n	$G_{m-3,n}$	$DG_{m-2,n}$	$G_{m-1,n}$	$DG_{m,n}$	$G_{m+1,n}$	$DG_{m+2,n}$	$G_{m+3,n}$	$DG_{m+4,n}$
$n+1$	$DG_{m-3,n+1}$	$G_{m-2,n+1}$	$DG_{m-1,n+1}$	$G_{m,n+1}$	$DG_{m+1,n+1}$	$G_{m+2,n+1}$	$DG_{m+3,n+1}$	$G_{m+4,n+1}$
$n+2$	$G_{m-3,n+2}$	$DG_{m-2,n+2}$	$G_{m-1,n+2}$	$DG_{m,n+2}$	$G_{m+1,n+2}$	$DG_{m+2,n+2}$	$G_{m+3,n+2}$	$DG_{m+4,n+2}$
$n+3$	$DG_{m-3,n+3}$	$G_{m-2,n+3}$	$DG_{m-1,n+3}$	$G_{m,n+3}$	$DG_{m+1,n+3}$	$G_{m+2,n+3}$	$DG_{m+3,n+3}$	$G_{m+4,n+3}$
$n+4$	$G_{m-3,n+4}$	$DG_{m-2,n+4}$	$G_{m-1,n+4}$	$DG_{m,n+4}$	$G_{m+1,n+4}$	$DG_{m+2,n+4}$	$G_{m+3,n+4}$	$DG_{m+4,n+4}$

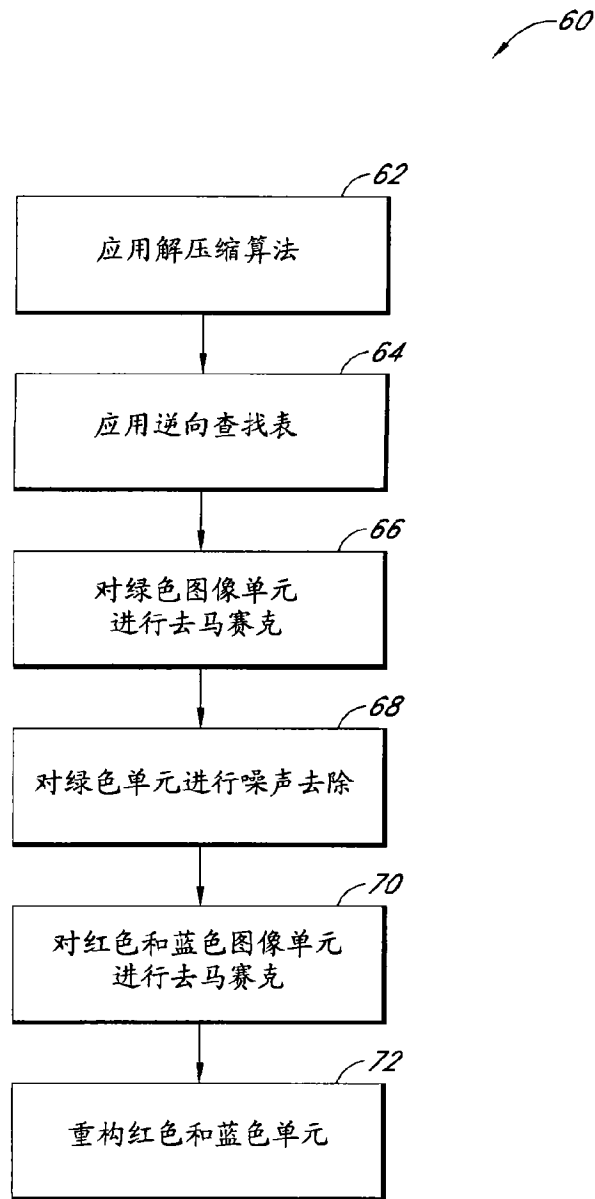
图 13

	$m-3$	$m-2$	$m-1$	m	$m+1$	$m+2$	$m+3$	$m+4$
$n-3$	$DG_{m-3,n-3}$	$DG_{m-2,n-3}$	$DG_{m-1,n-3}$	$DG_{m,n-3}$	$DG_{m+1,n-3}$	$DG_{m+2,n-3}$	$DG_{m+3,n-3}$	$DG_{m+4,n-3}$
$n-2$	$G_{m-3,n-2}$	$DG_{m-2,n-2}$	$G_{m-1,n-2}$	$DG_{m,n-2}$	$G_{m+1,n-2}$	$DG_{m+2,n-2}$	$G_{m+3,n-2}$	$DG_{m+4,n-2}$
$n-1$	$DG_{m-3,n-1}$	$DG_{m-2,n-1}$	$DG_{m-1,n-1}$	$DG_{m,n-1}$	$DG_{m+1,n-1}$	$DG_{m+2,n-1}$	$DG_{m+3,n-1}$	$DG_{m+4,n-1}$
n	$G_{m-3,n}$	$DG_{m-2,n}$	$G_{m-1,n}$	$DG_{m,n}$	$G_{m+1,n}$	$DG_{m+2,n}$	$G_{m+3,n}$	$DG_{m+4,n}$
$n+1$	$DG_{m-3,n+1}$	$DG_{m-2,n+1}$	$DG_{m-1,n+1}$	$DG_{m,n+1}$	$DG_{m+1,n+1}$	$DG_{m+2,n+1}$	$DG_{m+3,n+1}$	$DG_{m+4,n+1}$
$n+2$	$G_{m-3,n+2}$	$DG_{m-2,n+2}$	$G_{m-1,n+2}$	$DG_{m,n+2}$	$G_{m+1,n+2}$	$DG_{m+2,n+2}$	$G_{m+3,n+2}$	$DG_{m+4,n+2}$
$n+3$	$DG_{m-3,n+3}$	$DG_{m-2,n+3}$	$DG_{m-1,n+3}$	$DG_{m,n+3}$	$DG_{m+1,n+3}$	$DG_{m+2,n+3}$	$DG_{m+3,n+3}$	$DG_{m+4,n+3}$
$n+4$	$G_{m-3,n+4}$	$DG_{m-2,n+4}$	$G_{m-1,n+4}$	$DG_{m,n+4}$	$G_{m+1,n+4}$	$DG_{m+2,n+4}$	$G_{m+3,n+4}$	$DG_{m+4,n+4}$

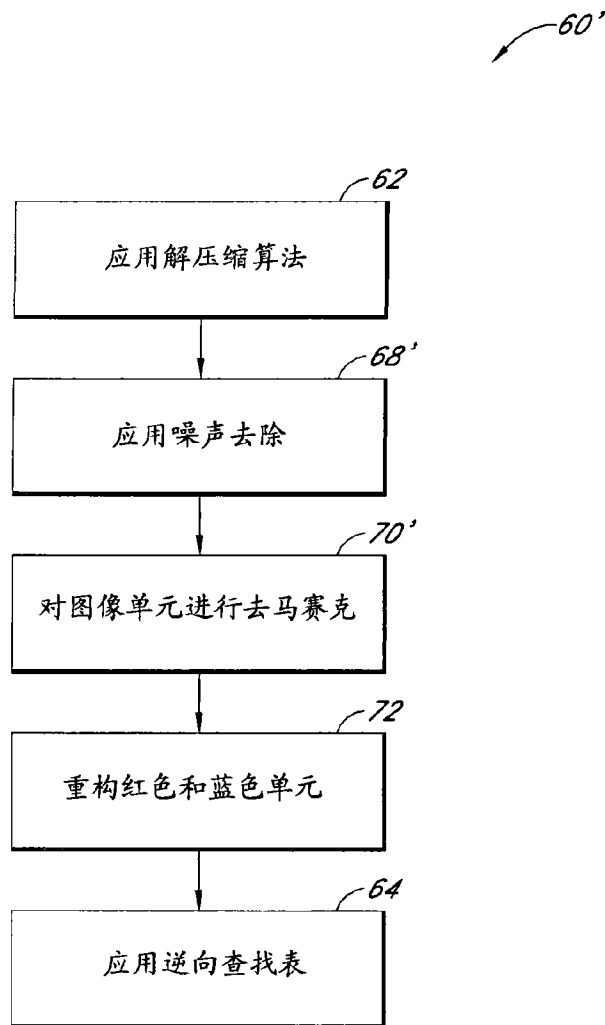
图 14

	$m-3$	$m-2$	$m-1$	m	$m+1$	$m+2$	$m+3$	$m+4$
$n-3$	$B_{m-3,n-3}$		$B_{m-1,n-3}$		$B_{m+1,n-3}$		$B_{m+3,n-3}$	
$n-2$								
$n-1$	$B_{m-3,n-1}$		$B_{m-1,n-1}$		$B_{m+1,n-1}$		$B_{m+3,n-1}$	
n								
$n+1$	$B_{m-3,n+1}$		$B_{m-1,n+1}$		$B_{m+1,n+1}$		$B_{m+3,n+1}$	
$n+2$								
$n+3$	$B_{m-3,n+3}$		$B_{m-1,n+3}$		$B_{m+1,n+3}$		$B_{m+3,n+3}$	
$n+4$								

图 15

	$m-3$	$m-2$	$m-1$	m	$m+1$	$m+2$	$m+3$	$m+4$
$n-3$	$B_{m-3,n-3}$	$DB_{m-2,n-3}$	$B_{m-1,n-3}$	$DB_{m,n-3}$	$B_{m+1,n-3}$	$DB_{m+2,n-3}$	$B_{m+3,n-3}$	$DB_{m+4,n-3}$
$n-2$	$DB_{m-3,n-2}$	$DB_{m-2,n-2}$	$DB_{m-1,n-2}$	$DB_{m,n-2}$	$DB_{m+1,n-2}$	$DB_{m+2,n-2}$	$DB_{m+3,n-2}$	$DB_{m+4,n-2}$
$n-1$	$B_{m-3,n-1}$	$DB_{m-2,n-1}$	$B_{m-1,n-1}$	$DB_{m,n-1}$	$B_{m+1,n-1}$	$DB_{m+2,n-1}$	$B_{m+3,n-1}$	$DB_{m+4,n-1}$
n	$DB_{m-3,n}$	$DB_{m-2,n}$	$DB_{m-1,n}$	$DB_{m,n}$	$DB_{m+1,n}$	$DB_{m+2,n}$	$DB_{m+3,n}$	$DB_{m+4,n}$
$n+1$	$B_{m-3,n+1}$	$DB_{m-2,n+1}$	$B_{m-1,n+1}$	$DB_{m,n+1}$	$B_{m+1,n+1}$	$DB_{m+2,n+1}$	$B_{m+3,n+1}$	$DB_{m+4,n+1}$
$n+2$	$DB_{m-3,n+2}$	$DB_{m-2,n+2}$	$DB_{m-1,n+2}$	$DB_{m,n+2}$	$DB_{m+1,n+2}$	$DB_{m+2,n+2}$	$DB_{m+3,n+2}$	$DB_{m+4,n+2}$
$n+3$	$B_{m-3,n+3}$	$DB_{m-2,n+3}$	$B_{m-1,n+3}$	$DB_{m,n+3}$	$B_{m+1,n+3}$	$DB_{m+2,n+3}$	$B_{m+3,n+3}$	$DB_{m+4,n+3}$
$n+4$	$DB_{m-3,n+4}$	$DB_{m-2,n+4}$	$DB_{m-1,n+4}$	$DB_{m,n+4}$	$DB_{m+1,n+4}$	$DB_{m+2,n+4}$	$DB_{m+3,n+4}$	$DB_{m+4,n+4}$

图 16

Electronic Patent Application Fee Transmittal

Application Number:	14485612
Filing Date:	12-Sep-2014
Title of Invention:	VIDEO CAMERA
First Named Inventor/Applicant Name:	James H. Jannard
Filer:	Sean Patrick Ambrosius/Jennifer Brown
Attorney Docket Number:	REDCOM.007C4

Filed as Large Entity

Filing Fees for Utility under 35 USC 111(a)

Description	Fee Code	Quantity	Amount	Sub-Total in USD(\$)
Basic Filing:				
Pages:				
Claims:				
Miscellaneous-Filing:				
Petition:				
Patent-Appeals-and-Interference:				
Post-Allowance-and-Post-Issuance:				
Extension-of-Time:				

Description	Fee Code	Quantity	Amount	Sub-Total in USD(\$)
Extension - 3 months with \$0 paid	1253	1	1400	1400
Miscellaneous:				
Submission- Information Disclosure Stmt	1806	1	180	180
Total in USD (\$)				1580

Electronic Acknowledgement Receipt

EFS ID:	22380024
Application Number:	14485612
International Application Number:	
Confirmation Number:	1068
Title of Invention:	VIDEO CAMERA
First Named Inventor/Applicant Name:	James H. Jannard
Customer Number:	20995
Filer:	Sean Patrick Ambrosius/Anthony Bonilla
Filer Authorized By:	Sean Patrick Ambrosius
Attorney Docket Number:	REDCOM.007C4
Receipt Date:	18-MAY-2015
Filing Date:	12-SEP-2014
Time Stamp:	19:51:33
Application Type:	Utility under 35 USC 111(a)

Payment information:

Submitted with Payment	yes
Payment Type	Credit Card
Payment was successfully received in RAM	\$1580
RAM confirmation Number	6945
Deposit Account	111410
Authorized User	KNOBBE MARTENS OLSON AND BEAR

The Director of the USPTO is hereby authorized to charge indicated fees and credit any overpayment as follows:

Charge any Additional Fees required under 37 C.F.R. Section 1.16 (National application filing, search, and examination fees)

Charge any Additional Fees required under 37 C.F.R. Section 1.17 (Patent application and reexamination processing fees)

File Listing:					
Document Number	Document Description	File Name	File Size(Bytes)/ Message Digest	Multi Part /.zip	Pages (if appl.)
1		REDCOM-007C4_Resp.pdf	3269842 c5652c0215a8743492b1cee2977456a09778c45f	yes	53
Multipart Description/PDF files in .zip description					
		Document Description	Start	End	
		Amendment/Req. Reconsideration-After Non-Final Reject	1	1	
		Claims	2	8	
		Applicant Arguments/Remarks Made in an Amendment	9	53	
Warnings:					
Information:					
2		REDCOM-007C4_IDS.pdf	178295 a1c495da65375380688c8486a9e6300791524889	yes	5
Multipart Description/PDF files in .zip description					
		Document Description	Start	End	
		Transmittal Letter	1	3	
		Information Disclosure Statement (IDS) Form (SB08)	4	5	
Warnings:					
Information:					
3	Foreign Reference	CA2831698.pdf	1608140 71f5a7a7d3ac8fd201a10be8be32b88be3312b7	no	50
Warnings:					
Information:					
4	Foreign Reference	JP2008-124976_w-MT.pdf	4178674 4ee176364be1f76949601b231cd4a146bc3ef2ce	no	67
Warnings:					
Information:					

5	Foreign Reference	KR_10-1478380_w-T.pdf	3504810	no	65
			bff4c6a6aeacf9b3cccd3446910079dccc2f5e2587		
Warnings:					
Information:					
6	Foreign Reference	WO99-12345.pdf	1050933	no	26
			447190c967fd409df62a64f3fd8a1899b2a9473a		
Warnings:					
Information:					
7	Non Patent Literature	2015-04-22_Notice- Opposition_REDCOM-007VEP. pdf	1193521	no	33
			010bc360903cbe73cb83a94d04c4758bd9b21304		
Warnings:					
Information:					
8	Non Patent Literature	2014-10-10_OA_KR-10-2014-70 21892_REDCOM-007VKRD1_w- T.pdf	326909	no	7
			b36338ff7b8621dc0babfe45743ed628381c6b77		
Warnings:					
Information:					
9	Foreign Reference	CN101689357_w-T.pdf	5867105	no	74
			59f087d959565e2b800f21fe74e7b1bdddd9e5c		
Warnings:					
Information:					
10	Fee Worksheet (SB06)	fee-info.pdf	32428	no	2
			ae0aea768bfeb3c7b99ce5577784525520d4993fb		
Warnings:					
Information:					
Total Files Size (in bytes):				21210657	

This Acknowledgement Receipt evidences receipt on the noted date by the USPTO of the indicated documents, characterized by the applicant, and including page counts, where applicable. It serves as evidence of receipt similar to a Post Card, as described in MPEP 503.

New Applications Under 35 U.S.C. 111

If a new application is being filed and the application includes the necessary components for a filing date (see 37 CFR 1.53(b)-(d) and MPEP 506), a Filing Receipt (37 CFR 1.54) will be issued in due course and the date shown on this Acknowledgement Receipt will establish the filing date of the application.

National Stage of an International Application under 35 U.S.C. 371

If a timely submission to enter the national stage of an international application is compliant with the conditions of 35 U.S.C. 371 and other applicable requirements a Form PCT/DO/EO/903 indicating acceptance of the application as a national stage submission under 35 U.S.C. 371 will be issued in addition to the Filing Receipt, in due course.

New International Application Filed with the USPTO as a Receiving Office

If a new international application is being filed and the international application includes the necessary components for an international filing date (see PCT Article 11 and MPEP 1810), a Notification of the International Application Number and of the International Filing Date (Form PCT/RO/105) will be issued in due course, subject to prescriptions concerning national security, and the date shown on this Acknowledgement Receipt will establish the international filing date of the application.

Under the Paperwork Reduction Act of 1995, no persons are required to respond to a collection of information unless it displays a valid OMB control number.

PATENT APPLICATION FEE DETERMINATION RECORD Substitute for Form PTO-875	Application or Docket Number 14/485,612	Filing Date 09/12/2014	<input type="checkbox"/> To be Mailed
---	---	----------------------------------	---------------------------------------

ENTITY: LARGE SMALL MICRO

APPLICATION AS FILED – PART I

FOR	NUMBER FILED	NUMBER EXTRA	RATE (\$)	FEE (\$)
<input type="checkbox"/> BASIC FEE (37 CFR 1.16(a), (b), or (c))	N/A	N/A	N/A	
<input type="checkbox"/> SEARCH FEE (37 CFR 1.16(k), (l), or (m))	N/A	N/A	N/A	
<input type="checkbox"/> EXAMINATION FEE (37 CFR 1.16(o), (p), or (q))	N/A	N/A	N/A	
TOTAL CLAIMS (37 CFR 1.16(i))	minus 20 =	*	X \$ =	
INDEPENDENT CLAIMS (37 CFR 1.16(h))	minus 3 =	*	X \$ =	
<input type="checkbox"/> APPLICATION SIZE FEE (37 CFR 1.16(s))	If the specification and drawings exceed 100 sheets of paper, the application size fee due is \$310 (\$155 for small entity) for each additional 50 sheets or fraction thereof. See 35 U.S.C. 41(a)(1)(G) and 37 CFR 1.16(s).			
<input type="checkbox"/> MULTIPLE DEPENDENT CLAIM PRESENT (37 CFR 1.16(j))				
* If the difference in column 1 is less than zero, enter "0" in column 2.			TOTAL	

APPLICATION AS AMENDED – PART II

	(Column 1)	(Column 2)	(Column 3)	PRESENT EXTRA	RATE (\$)	ADDITIONAL FEE (\$)
AMENDMENT	05/18/2015	CLAIMS REMAINING AFTER AMENDMENT	HIGHEST NUMBER PREVIOUSLY PAID FOR			
	Total (37 CFR 1.16(i))	* 30	Minus	** 30	= 0	X \$80 = 0
	Independent (37 CFR 1.16(h))	* 2	Minus	***3	= 0	X \$420 = 0
	<input type="checkbox"/> Application Size Fee (37 CFR 1.16(s))					
<input type="checkbox"/> FIRST PRESENTATION OF MULTIPLE DEPENDENT CLAIM (37 CFR 1.16(j))						
					TOTAL ADD'L FEE	0

	(Column 1)	(Column 2)	(Column 3)	PRESENT EXTRA	RATE (\$)	ADDITIONAL FEE (\$)
AMENDMENT		CLAIMS REMAINING AFTER AMENDMENT	HIGHEST NUMBER PREVIOUSLY PAID FOR			
	Total (37 CFR 1.16(i))	*	Minus	**	=	X \$ =
	Independent (37 CFR 1.16(h))	*	Minus	***	=	X \$ =
	<input type="checkbox"/> Application Size Fee (37 CFR 1.16(s))					
<input type="checkbox"/> FIRST PRESENTATION OF MULTIPLE DEPENDENT CLAIM (37 CFR 1.16(j))						
					TOTAL ADD'L FEE	

* If the entry in column 1 is less than the entry in column 2, write "0" in column 3.
 ** If the "Highest Number Previously Paid For" IN THIS SPACE is less than 20, enter "20".
 *** If the "Highest Number Previously Paid For" IN THIS SPACE is less than 3, enter "3".

The "Highest Number Previously Paid For" (Total or Independent) is the highest number found in the appropriate box in column 1.

LIE
/CORALIA BETANCOURT/

This collection of information is required by 37 CFR 1.16. The information is required to obtain or retain a benefit by the public which is to file (and by the USPTO to process) an application. Confidentiality is governed by 35 U.S.C. 122 and 37 CFR 1.14. This collection is estimated to take 12 minutes to complete, including gathering, preparing, and submitting the completed application form to the USPTO. Time will vary depending upon the individual case. Any comments on the amount of time you require to complete this form and/or suggestions for reducing this burden, should be sent to the Chief Information Officer, U.S. Patent and Trademark Office, U.S. Department of Commerce, P.O. Box 1450, Alexandria, VA 22313-1450. DO NOT SEND FEES OR COMPLETED FORMS TO THIS ADDRESS. **SEND TO: Commissioner for Patents, P.O. Box 1450, Alexandria, VA 22313-1450.**

If you need assistance in completing the form, call 1-800-PTO-9199 and select option 2.



UNITED STATES PATENT AND TRADEMARK OFFICE

UNITED STATES DEPARTMENT OF COMMERCE
United States Patent and Trademark Office
Address: COMMISSIONER FOR PATENTS
P.O. Box 1450
Alexandria, Virginia 22313-1450
www.uspto.gov

Table with 5 columns: APPLICATION NO., FILING DATE, FIRST NAMED INVENTOR, ATTORNEY DOCKET NO., CONFIRMATION NO.
14/485,612 09/12/2014 James H. Jannard REDCOM.007C4 1068

20995 7590 07/01/2015
KNOBBE MARTENS OLSON & BEAR LLP
2040 MAIN STREET
FOURTEENTH FLOOR
IRVINE, CA 92614

EXAMINER

DIEP, TRUNG T

ART UNIT PAPER NUMBER

2664

NOTIFICATION DATE DELIVERY MODE

07/01/2015

ELECTRONIC

Please find below and/or attached an Office communication concerning this application or proceeding.

The time period for reply, if any, is set in the attached communication.

Notice of the Office communication was sent electronically on above-indicated "Notification Date" to the following e-mail address(es):

jayna.cartee@knobbe.com
efiling@knobbe.com

Applicant-Initiated Interview Summary	Application No. 14/485,612	Applicant(s) JANNARD ET AL.	
	Examiner TRUNG DIEP	Art Unit 2664	

All participants (applicant, applicant's representative, PTO personnel):

- (1) TRUNG DIEP. (3)_____.
- (2) Attorney Micheal Guiliana. (4)_____.

Date of Interview: 26 June 2015.

Type: Telephonic Video Conference
 Personal [copy given to: applicant applicant's representative]

Exhibit shown or demonstration conducted: Yes No.
If Yes, brief description: _____.

Issues Discussed 101 112 102 103 Others
(For each of the checked box(es) above, please describe below the issue and detailed description of the discussion)

Claim(s) discussed: Independent claims.

Identification of prior art discussed: Ishii.

Substance of Interview

(For each issue discussed, provide a detailed description and indicate if agreement was reached. Some topics may include: identification or clarification of a reference or a portion thereof, claim interpretation, proposed amendments, arguments of any applied references etc...)

The personal interview was conducted between Examiner Diep and Attorney Guiliana on 06/26/2015. Discussions included and mainly concentrated on Applicant's Arguments/Remarks filed on 05/18/2015 which Attorney Guiliana has agreed that a supplemental response will be filed within the next couple of weeks..

Applicant recordation instructions: The formal written reply to the last Office action must include the substance of the interview. (See MPEP section 713.04). If a reply to the last Office action has already been filed, applicant is given a non-extendable period of the longer of one month or thirty days from this interview date, or the mailing date of this interview summary form, whichever is later, to file a statement of the substance of the interview

Examiner recordation instructions: Examiners must summarize the substance of any interview of record. A complete and proper recordation of the substance of an interview should include the items listed in MPEP 713.04 for complete and proper recordation including the identification of the general thrust of each argument or issue discussed, a general indication of any other pertinent matters discussed regarding patentability and the general results or outcome of the interview, to include an indication as to whether or not agreement was reached on the issues raised.

Attachment

/TRUNG DIEP/
Primary Examiner, Art Unit 2664

Summary of Record of Interview Requirements

Manual of Patent Examining Procedure (MPEP), Section 713.04, Substance of Interview Must be Made of Record

A complete written statement as to the substance of any face-to-face, video conference, or telephone interview with regard to an application must be made of record in the application whether or not an agreement with the examiner was reached at the interview.

Title 37 Code of Federal Regulations (CFR) § 1.133 Interviews

Paragraph (b)

In every instance where reconsideration is requested in view of an interview with an examiner, a complete written statement of the reasons presented at the interview as warranting favorable action must be filed by the applicant. An interview does not remove the necessity for reply to Office action as specified in §§ 1.111, 1.135. (35 U.S.C. 132)

37 CFR §1.2 Business to be transacted in writing.

All business with the Patent or Trademark Office should be transacted in writing. The personal attendance of applicants or their attorneys or agents at the Patent and Trademark Office is unnecessary. The action of the Patent and Trademark Office will be based exclusively on the written record in the Office. No attention will be paid to any alleged oral promise, stipulation, or understanding in relation to which there is disagreement or doubt.

The action of the Patent and Trademark Office cannot be based exclusively on the written record in the Office if that record is itself incomplete through the failure to record the substance of interviews.

It is the responsibility of the applicant or the attorney or agent to make the substance of an interview of record in the application file, unless the examiner indicates he or she will do so. It is the examiner's responsibility to see that such a record is made and to correct material inaccuracies which bear directly on the question of patentability.

Examiners must complete an Interview Summary Form for each interview held where a matter of substance has been discussed during the interview by checking the appropriate boxes and filling in the blanks. Discussions regarding only procedural matters, directed solely to restriction requirements for which interview recordation is otherwise provided for in Section 812.01 of the Manual of Patent Examining Procedure, or pointing out typographical errors or unreadable script in Office actions or the like, are excluded from the interview recordation procedures below. Where the substance of an interview is completely recorded in an Examiners Amendment, no separate Interview Summary Record is required.

The Interview Summary Form shall be given an appropriate Paper No., placed in the right hand portion of the file, and listed on the "Contents" section of the file wrapper. In a personal interview, a duplicate of the Form is given to the applicant (or attorney or agent) at the conclusion of the interview. In the case of a telephone or video-conference interview, the copy is mailed to the applicant's correspondence address either with or prior to the next official communication. If additional correspondence from the examiner is not likely before an allowance or if other circumstances dictate, the Form should be mailed promptly after the interview rather than with the next official communication.

The Form provides for recordation of the following information:

- Application Number (Series Code and Serial Number)
- Name of applicant
- Name of examiner
- Date of interview
- Type of interview (telephonic, video-conference, or personal)
- Name of participant(s) (applicant, attorney or agent, examiner, other PTO personnel, etc.)
- An indication whether or not an exhibit was shown or a demonstration conducted
- An identification of the specific prior art discussed
- An indication whether an agreement was reached and if so, a description of the general nature of the agreement (may be by attachment of a copy of amendments or claims agreed as being allowable). Note: Agreement as to allowability is tentative and does not restrict further action by the examiner to the contrary.
- The signature of the examiner who conducted the interview (if Form is not an attachment to a signed Office action)

It is desirable that the examiner orally remind the applicant of his or her obligation to record the substance of the interview of each case. It should be noted, however, that the Interview Summary Form will not normally be considered a complete and proper recordation of the interview unless it includes, or is supplemented by the applicant or the examiner to include, all of the applicable items required below concerning the substance of the interview.

A complete and proper recordation of the substance of any interview should include at least the following applicable items:

- 1) A brief description of the nature of any exhibit shown or any demonstration conducted,
- 2) an identification of the claims discussed,
- 3) an identification of the specific prior art discussed,
- 4) an identification of the principal proposed amendments of a substantive nature discussed, unless these are already described on the Interview Summary Form completed by the Examiner,
- 5) a brief identification of the general thrust of the principal arguments presented to the examiner,
(The identification of arguments need not be lengthy or elaborate. A verbatim or highly detailed description of the arguments is not required. The identification of the arguments is sufficient if the general nature or thrust of the principal arguments made to the examiner can be understood in the context of the application file. Of course, the applicant may desire to emphasize and fully describe those arguments which he or she feels were or might be persuasive to the examiner.)
- 6) a general indication of any other pertinent matters discussed, and
- 7) if appropriate, the general results or outcome of the interview unless already described in the Interview Summary Form completed by the examiner.

Examiners are expected to carefully review the applicant's record of the substance of an interview. If the record is not complete and accurate, the examiner will give the applicant an extendable one month time period to correct the record.

Examiner to Check for Accuracy

If the claims are allowable for other reasons of record, the examiner should send a letter setting forth the examiner's version of the statement attributed to him or her. If the record is complete and accurate, the examiner should place the indication, "Interview Record OK" on the paper recording the substance of the interview along with the date and the examiner's initials.

IN THE UNITED STATES PATENT AND TRADEMARK OFFICE

Inventor	: James H. Jannard
App. No.	: 14/485,612
Filed	: September 12, 2014
For	: VIDEO CAMERA
Examiner	: Diep, Trung T.
Art Unit	: 2664
Conf. No.	: 1068

SUPPLEMENTAL RESPONSE AND INTERVIEW SUMMARY**Mail Stop Amendment**

Commissioner for Patents

P.O. Box 1450

Alexandria, VA 22313-1450

Dear Sir:

Supplemental to the Amendment filed May 18, 2015, in response to the Office Action dated November 17, 2014, Applicant respectfully submits the following Supplemental Remarks, Declaration, and Interview Summary.

Summary of Interview begins on page 2 of this paper.

Remarks begin on page 4 of this paper.

Application No.: 14/485,612
Filing Date: September 12, 2014

SUMMARY OF INTERVIEW

Attendees, Date and Type of Interview

The interview was conducted on June 26, 2015 and attended by Examiner Trung Diep and Michael Guiliana, Attorney for Applicant.

Exhibits and/or Demonstrations

N/A

Identification of Claims Discussed

Claims 1 and 15.

Identification of Prior Art Discussed

U.S. Patent No. 7,898,575 issued to Ishii

Proposed Amendments

None

Principal Arguments and Other Matters

During the interview, Applicant's counsel and the Examiner primarily discussed the Ishii reference with regard to the issue of whether the Ishii reference discloses processing and compression of demosaiced imaged data or whether it is silent as to whether image data is demosaiced. In particular, Applicant's counsel noted that the Ishii reference indicates that the image processing unit 104 performs "Bayer interpolation" in four (4) places in the specification. Additionally, the Ishii reference indicates that the image processing unit 104 also performs "color correction" in the same four (4) locations.

Applicant's counsel explained that the term "Bayer interpolation" is a term used by those of ordinary skill in the art to refer to the process of demosaicing image data output from a Bayer-patterned image sensor. The principle of operation of Bayer pattern image sensors is well known to those of ordinary skill in the art and thus those of ordinary skill in the art would understand the term "Bayer interpolation" as referring to the process of demosaicing image data from a Bayer patterned image sensor.

Application No.: 14/485,612
Filing Date: September 12, 2014

Further, Applicant's counsel explained that the term "color correction" is a reference, known to those of ordinary skill in the art, to refer to a process of adjusting an overall color of an image, adjustments that cannot be performed on image data prior to demosaicing. As such, the reference to Bayer interpolation and color correction would be understood as an explicit teaching that image data in the processing unit 104 of the Ishii reference is expressly disclosed as being demosaiced.

Results of Interview

As a result of the interview, the Examiner agreed that the outstanding rejections would be overcome if Applicant provided a further declaration explaining that the Ishii reference expressly discloses that the imaged data is demosaiced prior to compression.

REMARKS

By way of the present Supplemental Response, Claims 1-30 remain pending in the present application, no claims having been amended, added, or added.

Supplemental to the Amendment filed May 18, 2015 in response to the Office Action mailed November 18, 2014, Applicant respectfully requests the Examiner to reconsider the above-captioned application in view of the following remarks.

Summary of Issues Presented in This Response

The remarks set forth below are addressed narrowly to the issues discussed during the interview and the outstanding rejections which are based on the Ishii reference. More specifically, the remarks set forth below are narrowly directed to the disclosure of Ishii that establishes that the image processing unit 104 of Ishii performs a demosaicing process on the image data prior to compression, consistent with and supplemental to the remarks set forth in the Response filed May 15, 2015.

The Proposed Ishii/Newman Combination Does Not Render the Claims Obvious

Claims 1-30 stand rejected as being obvious under 35 U.S.C. § 103 based on the combination of Ishii (U.S. Patent No. 7,898,575) and Newman (U.S. Pat. No. 8,014,597). Applicant respectfully traverses the rejections for the reasons set forth below.

Ishii describes an image pickup device and image recording apparatus, but fails to teach de-mosaicing image data prior to compression,

Ishii describes demosaicing image data prior to compression. This is made clear throughout Ishii in at least the following passages:

The image processing unit 104 *performs predetermined image processes such as Bayer interpolation* and color correction for the imaged signals that have been supplied by the sensor 103.

Ishii column 5, lines 38-41 (emphasis added).

In the 4k image pickup mode, the sensor 103 supplies image signals of an image size of 4096×2160 so that the image processing unit 104 *performs the Bayer interpolation* and the color correction...

Ishii column 5, lines 53-56 (emphasis added).

In the 2k image pickup mode, the sensor 103 supplies image signals of an image size of 3072×1620 so that the image processing unit 104 *performs the Bayer interpolation* and the color correction...

Ishii column 5, lines 59-62 (emphasis added).

In the 720 p image pickup mode, the sensor 103 supplies image signals of an image size of 1920×1080 so that the image processing unit 104 *performs the Bayer interpolation* and the color correction...

Ishii column 5, lines 64-67 (emphasis added).

One of ordinary skill in the art understands that the term “interpolation” is often used in reference to demosaicing process. Moreover, it is also known that functions including color correction *can only be performed on demosaiced data*. Declaration of Graeme Nattress, January 31, 2014, ¶ 38 (copy submitted herewith).

Submitted herewith is a Declaration by co-inventor Thomas Graeme Nattress. As noted in the Nattress Declaration, the terms “Bayer interpolation” and “color correction” are well known in the art of video image processing, but they are not explicitly defined in the text of the Ishii patent. Nattress Decl., ¶ 4.

It is well known in the art that ‘Bayer interpolation’ algorithms are those algorithms that are used to calculate values for the missing R, G, and B values for every pixel location based on mathematical interpolation ...

Nattress Decl., ¶ 6.

The process performed by these Bayer interpolation algorithms is also referred to as ‘demosaicing’ Bayer-patterned image data.

Nattress Decl., ¶ 6.

Thus, Applicant submits that the above noted uses of “Bayer interpolation” in Ishii reference indicates to one of ordinary skill in the art that the image processing unit 104 performs demosaicing on the imaged data.

Further, the Nattress Declaration explains that the term “color correction” is a type of technique for correcting or altering the “overall color of a captured image.” Nattress Decl., ¶ 7. However, “mosaiced image data, including Bayer-patterned image data, does not define an ‘overall color of an image.’” Nattress Decl., ¶ 8. “Rather, the ‘overall color’ of an image represented by Bayer-patterned or mosaiced image data would not be known until the data is demosaiced.” Nattress Decl., ¶ 8. Thus, one of ordinary skill in the art understands that “color correction” cannot be performed on Bayer-patterned or mosaiced image data. Nattress Decl., ¶ 8.

Based on the disclosure of the Ishii reference, the Nattress Declaration concludes that “one of ordinary skill in the art would have concluded that the Ishii patent described is demosaicing image data *prior to compression.*” Nattress Decl., ¶ 8 (emphasis in original).

In light of the above-described reasons, the Patent Owner submits that one of ordinary skill in the art would conclude that Ishii reference is written with the assumption that the reader would understand that the well-known technique of *demosaicing would necessarily be performed prior to compression.*

Independent Claim 1

In contrast to Ishii, Claim 1 recites, among other recitations:

electronics having an image processing module and a compression module implemented therein,

the image processing module connected between the image sensor and the memory device, the image processing module configured to process the raw mosaiced image data from the image sensor and output processed image data based on the raw mosaiced image data from the image sensor, the processed image data including less than three data values for each of the light sensitive devices included in the first, second, and third pluralities of light sensitive devices, and

the compression module connected between the image sensor and the memory device, the compression module configured to *compress the processed image data* with a mathematically lossy compression technique *into compressed processed image data such that the compressed processed image data can be decompressed and demosaiced into a substantially visually lossless image of at least 2k resolution,*

wherein the memory device receives the compressed processed image data at a rate of at least about 23 frames per second.

Independent Claim 16

In contrast to Ishii, Claim 16 recites, among other recitations:

with electronics of the camera, processing the mosaiced image data from the image sensor and outputting processed image data based on the mosaiced image data from the image sensor, the processed image data including less than three data values for each of the light sensitive devices included in the first, second, and third pluralities of light sensitive devices;

with electronics of the camera, compressing the processed image data with a mathematically lossy compression technique into compressed processed image data such that the compressed processed image data can be decompressed and demosaiced into a substantially visually lossless image of at least 2k resolution; and

recording the compressed processed image data onto a memory device of the camera at a rate of at least about 23 frames per second.

Application No.: 14/485,612
Filing Date: September 12, 2014

Thus, in consideration of both the remarks set forth herein and the remarks set forth in the response filed June 10, 2015, Applicants submit that Claims 1 and 16 clearly and nonobviously defines over the cited references.

No Disclaimers or Disavowals

Although the present communication may include alterations to the application or claims, or characterizations of claim scope or referenced art, Applicant is not conceding in this application that previously pending claims are not patentable over the cited references. Rather, any alterations or characterizations are being made to facilitate expeditious prosecution of this application. Applicant reserves the right to pursue at a later date any previously pending or other broader or narrower claims that capture any subject matter supported by the present disclosure, including subject matter found to be specifically disclaimed herein or by any prior prosecution. Accordingly, reviewers of this or any parent, child or related prosecution history shall not reasonably infer that Applicant has made any disclaimers or disavowals of any subject matter supported by the present application.

Co-Pending and Other Applications of Assignee

Applicant wishes to draw the Examiner's attention to the following applications of the present application's assignee, some of which are co-pending.

Docket No.	Serial No.	Patent/ Publication No.	Title	Filed
REDCOM.007A	12/101,882	8,174,560	VIDEO CAMERA	04/11/2008
REDCOM.007C1	13/464,803	2012/0294582	VIDEO CAMERA	05/04/2012
REDCOM.007C2	13/566,868	8,358,357	VIDEO CAMERA	08/03/2012
REDCOM.007C3	14/485,611	N/A	VIDEO CAMERA	09/12/2014
REDCOM.007CP1	12/422,507	8,237,830	VIDEO CAMERA	04/13/2009
REDCOM.007CP1C1	12/834,854	7,830,967	VIDEO CAMERA	07/12/2010
REDCOM.007CP1C2	13/566,924	2013/0113951	VIDEO CAMERA	08/03/2012
REDCOM.007P1C3	14/488,030	N/A	VIDEO CAMERA	09/16/2014

Application No.: 14/485,612
Filing Date: September 12, 2014

Docket No.	Serial No.	Patent/ Publication No.	Title	Filed
REDCOM.007X1 (reexamination of REDCOM.007A)	90/012,550	8,174,560 C1	VIDEO CAMERA	09/13/2012

Applicant notes that cited references, office actions, responses and notices of allowance currently exist or will exist for the above-referenced matters. Applicant also understands that the Examiner has access to sophisticated online Patent Office computing systems that provide ready access to the full file histories of these matters including, for example, specifications, drawings, pending claims, cited art, office actions, responses, declarations, and notices of allowance. Rather than submit copies these file histories, Applicant respectfully requests that the Examiner continue to review these file histories online for past, current, and future information about these matters. Also, if the Examiner cannot readily access these file histories, the Applicant would be pleased to provide any portion of any of the file histories at any time upon specific Examiner request.

Please charge any additional fees, including any fees for additional extension of time, or credit overpayment to Deposit Account No. 11-1410.

Respectfully submitted,

KNOBBE, MARTENS, OLSON & BEAR, LLP

Dated: August 3, 2015

By: /Michael Guiliana/

Michael A. Guiliana
Registration No. 42,611
Attorney of Record
Customer No. 20995
(949) 760-0404

21188896

IN THE UNITED STATES PATENT AND TRADEMARK OFFICE

Inventor : James Jannard, et al.
App. No. : 14/485,611; 14/485,612
Filed : September 12, 2014
For : VIDEO CAMERA
Examiner : Diep, Trung
Art Unit : 2664

DECLARATION OF THOMAS GRAEME NATTRESS UNDER 37 C.F.R. §1.132**Mail Stop Amendment**

Commissioner for Patents
P.O. Box 1450
Alexandria, VA 22313-1450

Dear Sir:

I, Thomas Graeme Nattress, declare that:

I. BACKGROUND

1. I am a lead camera systems architect at Red.com, Inc. (dba Red Digital Camera) (“RED”), the assignee of U.S. Patent Application Nos. 14/485,611 and 14/485,612 (“the ‘611 and ‘622 applications”). I am also a listed inventor on the ‘611 and ‘612 applications.
2. A detailed summary of my biography and credentials can be found in a previous declaration I executed under 37 C.F.R. §1.132 (“the Previous Declaration”), which was submitted on July 1, 2013 in a reexamination proceeding involving U.S. Patent No. 8,174,560 (Reexam No. 90/012,550, resulting in Reexamination Certificate No. 8,174,560 C1). U.S. Patent No. 8,174,560 is relied upon for an earlier filing date by the ‘611 and

'622 applications under 35 U.S.C. § 120. A copy of the Previous Declaration is being submitted herewith.

3. I understand that the claims in the '611 and '612 applications currently stand rejected based on a combination of references including U.S. Patent No. 7,898,575 to Ishii ("the Ishii patent"). I have reviewed the Ishii patent.
4. The Ishii patent uses several terms, such as "Bayer interpolation" and "color correction" that are well known in the art of video image processing, but that are not explicitly defined in the text of the Ishii patent. Thus, set forth below is a brief explanation of the meaning of those terms as understood by those of ordinary skill in the art as of about April 2007.
5. Many digital cameras have monochrome CCD image sensors with each pixel location painted with a Red (R), Green (G) or Blue (B) filter. This alternating R, G and B filter matrix most often follows the "Bayer pattern" with twice as many G as R or B pixels. This is named for Kodak scientist Bryce Bayer who is known to have invented it in 1976. Data read from these types of image sensors is referred to as "Bayer-patterned" or "mosaic" image data.
6. It is well known in the art that "Bayer interpolation algorithms" are those algorithms that are used to calculate values for the missing R, G and B values for every pixel location based on mathematical interpolation of the nearby R, G, and B values that are included in the data from a "Bayer-patterned" image sensor. The process performed by these Bayer interpolation algorithms is also referred to as "de-mosaicing" Bayer-patterned image data.
7. The term "color correction", whether used in the film or digital photography arts, refers to processes for altering the *overall color* of a captured image. Although sensors can perceive

red, green and blue light via dyes in the color filter array included on the CCD image sensor, the dyes do not match the response of the human visual system. Color correction processes are designed to correct for this and/or to provide other aesthetic effects, by adjusting hues in the image so that the colors in the scene have the desired appearance to the viewer. In order to adjust hues in the image, the color correction matrix must operate on full color resolution, demosaiced image data. For example, to add or subtract some percentage of green or blue from red for a pixel to alter the hue of that pixel from a slightly orange-ish red to a pure firetruck red, intensity values for all three colors--red, green, and blue--are needed for that pixel. Moreover, some color correction matrices are also designed to increase image saturation in order to counteract a corresponding reduction in image saturation that results from a degree of color cross-talk due to overlap in the color response of the dyes in the color filter array. In order to increase image saturation and counteract the color cross-talk, all of the color values (R, G, B) are needed for *each pixel*. For instance, to subtract a percentage of red and blue from green for a particular pixel, values for all three colors are needed for that pixel.

8. Mosaiced image data, including Bayer-patterned image data, does not define an “overall color” of an image. Rather, the “overall color” of an image represented by Bayer-patterned or mosaiced image data would not be known until that data is demosaiced. Thus, one of ordinary skill in the art understands that “color correction” cannot be performed on Bayer-patterned or mosaiced image data.
9. The Ishii reference describes several different methods for processing image data from a Bayer-pattern image sensor. Ishii includes the following passages that are specifically directed to the type of data and the processes performed:

The image processing unit 104 *performs predetermined image processes such as Bayer interpolation and color correction* for the image signals that have been supplied by the sensor 103.

Ishii column 5, lines 38-41.

In the 4k image pickup mode, the sensor 103 supplies image signals of an image size of 4096×2160 so that the image processing unit 104 *performs the Bayer interpolation and the color correction...*

Ishii column 5, lines 53-56.

In the 2k image pickup mode, the sensor 103 supplies image signals of an image size of 3072×1620 so that the image processing unit 104 *performs the Bayer interpolation and the color correction...*

Ishii column 5, lines 59-62.

In the 720 p image pickup mode, the sensor 103 supplies image signals of an image size of 1920×1080 so that the image processing unit 104 *performs the Bayer interpolation and the color correction...*

Ishii column 5, lines 64-67.

10. The above noted cites represent all of the uses of the term “color correction” in the Ishii specification. In all of these uses, the term “color correction” only appears after the term “Bayer interpolation”.
11. In this context, the term “Bayer interpolation” would have been understood by one of ordinary skill in the art to correspond to a *de-mosaicing* of the image data at the image processing unit 104. Thus, one of ordinary skill in the art would have concluded that the Ishii patent describes demosaicing image data *prior to compression*.
12. Moreover, the term “color correction” referred to in the above-passages from the Ishii patent was well known to those of ordinary skill in the art as being performed on demosaiced image data. Thus, the above references to “color correction” after “Bayer

Application No.: 14/485,611; 14/485,612

Filing Date: September 12, 2014

interpolation” is consistent with the understanding of one of ordinary skill in the art that color correction is only performed on demosaiced image data.

13. Ishii describes several configurations for compressing video data, for example with reference to Figure 24 of Ishii. Specifically, Ishii describes “compression units 112a-112d” as compressing image signals output from the output selecting unit 105. Ishii, column 21, lines 3-7. The output selecting unit 105 receives the image signals from image processing unit 104 (Ishii column 8, lines 16-20), which as noted above, performs Bayer interpolation and color correction. Thus, all of the image signals supplied to the compression units 112a-112d are demosaiced image data.

14. There is no other disclosure in the Ishii reference that describes compression of Bayer-patterned or mosaiced image data.

15. Thus, the Ishii patent describes compressing demosaiced image data, but not compressing mosaiced data.

16. All statements made herein of my own knowledge are true. All statements made on information and belief are believed to be true. These statements were made with the knowledge that willful false statements and the like so made are punishable by fine, imprisonment, or both, under 18 U.S.C. § 1001, and that such willful false statements may jeopardize the validity of the application or any patent issuing therefrom.

Dated: June 29, 2015



Thomas Graeme Nattress

21006801

Electronic Acknowledgement Receipt

EFS ID:	23097049
Application Number:	14485612
International Application Number:	
Confirmation Number:	1068
Title of Invention:	VIDEO CAMERA
First Named Inventor/Applicant Name:	James H. Jannard
Customer Number:	20995
Filer:	Michael A. Guiliana/Sandra Autry
Filer Authorized By:	Michael A. Guiliana
Attorney Docket Number:	REDCOM.007C4
Receipt Date:	03-AUG-2015
Filing Date:	12-SEP-2014
Time Stamp:	16:12:40
Application Type:	Utility under 35 USC 111(a)

Payment information:

Submitted with Payment	no
------------------------	----

File Listing:

Document Number	Document Description	File Name	File Size(Bytes)/ Message Digest	Multi Part /.zip	Pages (if appl.)
1		REDCOM007C4_Supplemental_Amendment_Interview_Summary.pdf	274525 <small>5afb71d8361564e13442beb90dca52ff4be8f3a2</small>	yes	8

Multipart Description/PDF files in .zip description			
	Document Description	Start	End
	Supplemental Response or Supplemental Amendment	1	1
	Applicant summary of interview with examiner	2	3
	Applicant Arguments/Remarks Made in an Amendment	4	8

Warnings:

Information:

2	Affidavit-traversing rejectns or objectns rule 132	Declaration_by_Nattress.pdf	243624	no	5
			a8f37c82af44ba82c5b54aab9cb6a09b9c8e ec59		

Warnings:

Information:

Total Files Size (in bytes):		518149
-------------------------------------	--	--------

This Acknowledgement Receipt evidences receipt on the noted date by the USPTO of the indicated documents, characterized by the applicant, and including page counts, where applicable. It serves as evidence of receipt similar to a Post Card, as described in MPEP 503.

New Applications Under 35 U.S.C. 111

If a new application is being filed and the application includes the necessary components for a filing date (see 37 CFR 1.53(b)-(d) and MPEP 506), a Filing Receipt (37 CFR 1.54) will be issued in due course and the date shown on this Acknowledgement Receipt will establish the filing date of the application.

National Stage of an International Application under 35 U.S.C. 371

If a timely submission to enter the national stage of an international application is compliant with the conditions of 35 U.S.C. 371 and other applicable requirements a Form PCT/DO/EO/903 indicating acceptance of the application as a national stage submission under 35 U.S.C. 371 will be issued in addition to the Filing Receipt, in due course.

New International Application Filed with the USPTO as a Receiving Office

If a new international application is being filed and the international application includes the necessary components for an international filing date (see PCT Article 11 and MPEP 1810), a Notification of the International Application Number and of the International Filing Date (Form PCT/RO/105) will be issued in due course, subject to prescriptions concerning national security, and the date shown on this Acknowledgement Receipt will establish the international filing date of the application.

Doc Code: DIST.E.FILE Document Description: Electronic Terminal Disclaimer - Filed	PTO/SB/25 U.S. Patent and Trademark Office Department of Commerce
---	---

Electronic Petition Request	TERMINAL DISCLAIMER TO OBLIATE A PROVISIONAL DOUBLE PATENTING REJECTION OVER A PENDING "REFERENCE" APPLICATION
Application Number	14485612
Filing Date	12-Sep-2014
First Named Inventor	James Jannard
Attorney Docket Number	REDCOM.007C4
Title of Invention	VIDEO CAMERA

- Filing of terminal disclaimer does not obviate requirement for response under 37 CFR 1.111 to outstanding Office Action
- This electronic Terminal Disclaimer is not being used for a Joint Research Agreement.

Owner	Percent Interest
RED.COM, INC.	100%

The owner(s) of percent interest listed above in the instant application hereby disclaims, except as provided below, the terminal part of the statutory term of any patent granted on the instant application which would extend beyond the expiration date of the full statutory term of any patent granted on pending reference Application Number(s)

14485611 filed on 09/12/2014

as the term of any patent granted on said reference application may be shortened by any terminal disclaimer filed prior to the grant of any patent on the pending reference application. The owner hereby agrees that any patent so granted on the instant application shall be enforceable only for and during such period that it and any patent granted on the reference application are commonly owned. This agreement runs with any patent granted on the instant application and is binding upon the grantee, its successors or assigns.

In making the above disclaimer, the owner does not disclaim the terminal part of any patent granted on the instant application that would extend to the expiration date of the full statutory term of any patent granted on said reference application, "as the term of any patent granted on said reference application may be shortened by any terminal disclaimer filed prior to the grant of any patent on the pending reference application," in the event that any such patent granted on the pending reference application: expires for failure to pay a maintenance fee, is held unenforceable, is found invalid by a court of competent jurisdiction, is statutorily disclaimed in whole or terminally disclaimed under 37 CFR 1.321, has all claims canceled by a reexamination certificate, is reissued, or is in any manner terminated prior to the expiration of its full statutory term as shortened by any terminal disclaimer filed prior to its grant.

- Terminal disclaimer fee under 37 CFR 1.20(d) is included with Electronic Terminal Disclaimer request.

I certify, in accordance with 37 CFR 1.4(d)(4), that the terminal disclaimer fee under 37 CFR 1.20(d) required for this terminal disclaimer has already been paid in the above-identified application.

Applicant claims the following fee status:

- Small Entity
- Micro Entity
- Regular Undiscounted

I hereby declare that all statements made herein of my own knowledge are true and that all statements made on information and belief are believed to be true; and further that these statements were made with the knowledge that willful false statements and the like so made are punishable by fine or imprisonment, or both, under Section 1001 of Title 18 of the United States Code and that such willful false statements may jeopardize the validity of the application or any patent issued thereon.

THIS PORTION MUST BE COMPLETED BY THE SIGNATORY OR SIGNATORIES

I certify, in accordance with 37 CFR 1.4(d)(4) that I am:

- An attorney or agent registered to practice before the Patent and Trademark Office who is of record in this application

Registration Number 42611
- A sole inventor
- A joint inventor; I certify that I am authorized to sign this submission on behalf of all of the inventors as evidenced by the power of attorney in the application
- A joint inventor; all of whom are signing this request

Signature	/Michael Guiliana/
Name	Michael A. Guiliana

*Statement under 37 CFR 3.73(b) is required if terminal disclaimer is signed by the assignee (owner).
Form PTO/SB/96 may be used for making this certification. See MPEP § 324.

Electronic Patent Application Fee Transmittal

Application Number:	14485612
Filing Date:	12-Sep-2014
Title of Invention:	VIDEO CAMERA
First Named Inventor/Applicant Name:	James H. Jannard
Filer:	Michael A. Guiliana/Anthony Bonilla
Attorney Docket Number:	REDCOM.007C4

Filed as Large Entity

Filing Fees for Utility under 35 USC 111(a)

Description	Fee Code	Quantity	Amount	Sub-Total in USD(\$)
Basic Filing:				
Statutory or Terminal Disclaimer	1814	1	160	160

Pages:

Claims:

Miscellaneous-Filing:

Petition:

Patent-Appeals-and-Interference:

Post-Allowance-and-Post-Issuance:

Description	Fee Code	Quantity	Amount	Sub-Total in USD(\$)
Extension-of-Time:				
Miscellaneous:				
Total in USD (\$)				160

Doc Code: DISQ.E.FILE

Document Description: Electronic Terminal Disclaimer – Approved

Application No.: 14485612

Filing Date: 12-Sep-2014

Applicant/Patent under Reexamination: Jannard et al.

Electronic Terminal Disclaimer filed on August 3, 2015

APPROVED

This patent is subject to a terminal disclaimer

DISAPPROVED

Approved/Disapproved by: Electronic Terminal Disclaimer automatically approved by EFS-Web

U.S. Patent and Trademark Office

Electronic Acknowledgement Receipt

EFS ID:	23101154
Application Number:	14485612
International Application Number:	
Confirmation Number:	1068
Title of Invention:	VIDEO CAMERA
First Named Inventor/Applicant Name:	James H. Jannard
Customer Number:	20995
Filer:	Michael A. Guiliana/Anthony Bonilla
Filer Authorized By:	Michael A. Guiliana
Attorney Docket Number:	REDCOM.007C4
Receipt Date:	03-AUG-2015
Filing Date:	12-SEP-2014
Time Stamp:	18:04:45
Application Type:	Utility under 35 USC 111(a)

Payment information:

Submitted with Payment	yes
Payment Type	Credit Card
Payment was successfully received in RAM	\$160
RAM confirmation Number	5141
Deposit Account	111410
Authorized User	KNOBBE MARTENS OLSON AND BEAR

The Director of the USPTO is hereby authorized to charge indicated fees and credit any overpayment as follows:

Charge any Additional Fees required under 37 C.F.R. Section 1.16 (National application filing, search, and examination fees)

Charge any Additional Fees required under 37 C.F.R. Section 1.17 (Patent application and reexamination processing fees)

--	--	--	--	--	--

File Listing:

Document Number	Document Description	File Name	File Size(Bytes)/ Message Digest	Multi Part /.zip	Pages (if appl.)
1	Electronic Terminal Disclaimer-Filed	eTerminal-Disclaimer.pdf	33926	no	2
			c60445212831f1914c0ed1036c9ea2cb2ebc13f7		

Warnings:

Information:

2	Fee Worksheet (SB06)	fee-info.pdf	30191	no	2
			2eb9b6d9f5fba50a6dbd5b55a27af17c38a1af35		

Warnings:

Information:

Total Files Size (in bytes):			64117		
-------------------------------------	--	--	-------	--	--

This Acknowledgement Receipt evidences receipt on the noted date by the USPTO of the indicated documents, characterized by the applicant, and including page counts, where applicable. It serves as evidence of receipt similar to a Post Card, as described in MPEP 503.

New Applications Under 35 U.S.C. 111

If a new application is being filed and the application includes the necessary components for a filing date (see 37 CFR 1.53(b)-(d) and MPEP 506), a Filing Receipt (37 CFR 1.54) will be issued in due course and the date shown on this Acknowledgement Receipt will establish the filing date of the application.

National Stage of an International Application under 35 U.S.C. 371

If a timely submission to enter the national stage of an international application is compliant with the conditions of 35 U.S.C. 371 and other applicable requirements a Form PCT/DO/EO/903 indicating acceptance of the application as a national stage submission under 35 U.S.C. 371 will be issued in addition to the Filing Receipt, in due course.

New International Application Filed with the USPTO as a Receiving Office

If a new international application is being filed and the international application includes the necessary components for an international filing date (see PCT Article 11 and MPEP 1810), a Notification of the International Application Number and of the International Filing Date (Form PCT/RO/105) will be issued in due course, subject to prescriptions concerning national security, and the date shown on this Acknowledgement Receipt will establish the international filing date of the application.

INFORMATION DISCLOSURE STATEMENT BY APPLICANT	Application No.	14/485612
	Filing Date	September 12, 2014
	First Named Inventor	James H. Jannard
	Art Unit	2664
<i>(Multiple sheets used when necessary)</i>	Examiner	Diep, Trung T.
SHEET 1 OF 1	Attorney Docket No.	REDCOM.007C4

U.S. PATENT DOCUMENTS						
Examiner Initials	Cite No.	Document Number <i>Number - Kind Code (if known)</i> Example: 1,234,567 B1	Publication Date MM-DD-YYYY	Name	Pages, Columns, Lines Where Relevant Passages or Relevant Figures Appear	
FOREIGN PATENT DOCUMENTS						
Examiner Initials	Cite No.	Foreign Patent Document <i>Country Code-Number-Kind Code</i> Example: JP 1234567 A1	Publication Date MM-DD-YYYY	Name	Pages, Columns, Lines Where Relevant Passages or Relevant Figures Appear	T ¹

NON PATENT LITERATURE DOCUMENTS			
Examiner Initials	Cite No.	Include name of the author (in CAPITAL LETTERS), title of the article (when appropriate), title of the item (book, magazine, journal, serial, symposium, catalog, etc.), date, page(s), volume-issue number(s), publisher, city and/or country where published.	T ¹
	1	Official Communication in Korean Application No. 10-2014-7021892 (REDCOM.007VKRD1), dated October 10, 2014.	X

20660190

Examiner Signature	Date Considered
<p>*Examiner: Initial if reference considered, whether or not citation is in conformance with MPEP 609. Draw line through citation if not in conformance and not considered. Include copy of this form with next communication to applicant.</p>	

T¹ - Place a check mark in this area when an English language Translation is attached.

Electronic Patent Application Fee Transmittal

Application Number:	14485612
Filing Date:	12-Sep-2014
Title of Invention:	VIDEO CAMERA
First Named Inventor/Applicant Name:	James H. Jannard
Filer:	Sean Patrick Ambrosius/Daniella Kellogg
Attorney Docket Number:	REDCOM.007C4

Filed as Large Entity

Filing Fees for Utility under 35 USC 111(a)

Description	Fee Code	Quantity	Amount	Sub-Total in USD(\$)
Basic Filing:				
Pages:				
Claims:				
Miscellaneous-Filing:				
Petition:				
Patent-Appeals-and-Interference:				
Post-Allowance-and-Post-Issuance:				
Extension-of-Time:				

Description	Fee Code	Quantity	Amount	Sub-Total in USD(\$)
Miscellaneous:				
Submission- Information Disclosure Stmt	1806	1	180	180
Total in USD (\$)				180

Electronic Acknowledgement Receipt

EFS ID:	23128505
Application Number:	14485612
International Application Number:	
Confirmation Number:	1068
Title of Invention:	VIDEO CAMERA
First Named Inventor/Applicant Name:	James H. Jannard
Customer Number:	20995
Filer:	Sean Patrick Ambrosius/Daniella Kellogg
Filer Authorized By:	Sean Patrick Ambrosius
Attorney Docket Number:	REDCOM.007C4
Receipt Date:	05-AUG-2015
Filing Date:	12-SEP-2014
Time Stamp:	19:38:27
Application Type:	Utility under 35 USC 111(a)

Payment information:

Submitted with Payment	yes
Payment Type	Credit Card
Payment was successfully received in RAM	\$180
RAM confirmation Number	5367
Deposit Account	111410
Authorized User	KNOBBE MARTENS OLSON AND BEAR

The Director of the USPTO is hereby authorized to charge indicated fees and credit any overpayment as follows:

Charge any Additional Fees required under 37 C.F.R. Section 1.16 (National application filing, search, and examination fees)

Charge any Additional Fees required under 37 C.F.R. Section 1.17 (Patent application and reexamination processing fees)

File Listing:					
Document Number	Document Description	File Name	File Size(Bytes)/ Message Digest	Multi Part /.zip	Pages (if appl.)
1	Non Patent Literature	OFFICE_ACTION_REDCOM-007 VKRD1.pdf	631876	no	4
			419ac200710960ab662f27877cbbcb59d82 f291a		
Warnings:					
Information:					
2		IDS_REDCOM-007C4.pdf	54306	yes	4
			04356ebc9ed6777cc3f6d0adb6c1c2b63fd df5ff		
	Multipart Description/PDF files in .zip description				
	Document Description		Start	End	
	Transmittal Letter		1	3	
	Information Disclosure Statement (IDS) Form (SB08)		4	4	
Warnings:					
Information:					
3	Fee Worksheet (SB06)	fee-info.pdf	30271	no	2
			df1d5159c985e0ba158124f9c06c92f389f4 3fcb		
Warnings:					
Information:					
Total Files Size (in bytes):			716453		

This Acknowledgement Receipt evidences receipt on the noted date by the USPTO of the indicated documents, characterized by the applicant, and including page counts, where applicable. It serves as evidence of receipt similar to a Post Card, as described in MPEP 503.

New Applications Under 35 U.S.C. 111

If a new application is being filed and the application includes the necessary components for a filing date (see 37 CFR 1.53(b)-(d) and MPEP 506), a Filing Receipt (37 CFR 1.54) will be issued in due course and the date shown on this Acknowledgement Receipt will establish the filing date of the application.

National Stage of an International Application under 35 U.S.C. 371

If a timely submission to enter the national stage of an international application is compliant with the conditions of 35 U.S.C. 371 and other applicable requirements a Form PCT/DO/EO/903 indicating acceptance of the application as a national stage submission under 35 U.S.C. 371 will be issued in addition to the Filing Receipt, in due course.

New International Application Filed with the USPTO as a Receiving Office

If a new international application is being filed and the international application includes the necessary components for an international filing date (see PCT Article 11 and MPEP 1810), a Notification of the International Application Number and of the International Filing Date (Form PCT/RO/105) will be issued in due course, subject to prescriptions concerning national security, and the date shown on this Acknowledgement Receipt will establish the international filing date of the application.

INFORMATION DISCLOSURE STATEMENT

Inventor	: James H. Jannard
App. No.	: 14/485612
Filed	: September 12, 2014
For	: VIDEO CAMERA
Examiner	: Diep, Trung T.
Art Unit	: 2664
Conf. No.	: 1068

Mail Stop Amendment
 Commissioner for Patents
 P.O. Box 1450
 Alexandria, VA 22313-1450

References and Listing

Pursuant to 37 CFR 1.56, an Information Disclosure Statement listing references is provided herewith.

In particular, submitted Reference No. 1 is an Official Communication in Korean Patent Application No. 10-2014-7021892, along with a partial English language translation, in four total pages. To the best of the knowledge of the undersigned, the translation includes a partial translation of page 1 of the Official Communication and a complete translation of page 2 of the Official Communication. No representation is made as to the accuracy of the translation.

If the Examiner would like additional information regarding these references or if anything is unclear, the Examiner is invited to contact the undersigned for assistance.

Pursuant to 37 C.F.R § 1.97(g) and (h), Applicants make no representation that the information is considered to be material to patentability. Additionally, inclusion on this list is not an admission that any of the cited documents are prior art in this application. Further, Applicants make no representation regarding the completeness of this list, or that better art does not exist.

Applicant wishes to draw the Examiner's attention to the following applications owned by of the present application's assignee:

Docket No.	Serial No.	Patent/ Publication No	Title	Filed
REDCOM.007A	12/101,882	8,174,560	VIDEO CAMERA	04/11/2008

Docket No.	Serial No.	Patent/ Publication No	Title	Filed
REDCOM.007CP1	12/422,507	8,237,830	VIDEO CAMERA	04/13/2009
REDCOM.007CP1C1	12/834,854	7,830,967	VIDEO CAMERA	07/12/2010
REDCOM.007C1	13/464,803	8,872,933	VIDEO CAMERA	05/04/2012
REDCOM.007C2	13/566,868	8,358,357	VIDEO CAMERA	08/03/2012
REDCOM.007CP1C2	13/566,924	8,878,952	VIDEO CAMERA	08/03/2012
REDCOM.007X1 (reexamination REDCOM.007A)	90/012,550	8,174,560 C1	VIDEO CAMERA	09/13/2012
REDCOM.007C3	14/485,611	2015/0003801	VIDEO CAMERA	09/12/2014
REDCOM.007P1C3	14/488,030	9,019,393	VIDEO PROCESSING SYSTEM AND METHOD	09/16/2014
REDCOM.007P1C4	14/609,090	N/A	VIDEO CAMERA	01/29/2015

Applicant notes that cited references, office actions, responses and notices of allowance currently exist or will exist for the above-referenced matters. Applicant also understands that the Examiner has access to sophisticated online Patent Office computing systems that provide ready access to the full file histories of these matters including, for example, specifications, drawings, pending claims, cited art, office actions, responses, declarations, and notices of allowance. Rather than submit copies these file histories, Applicant respectfully requests that the Examiner continue to review these file histories online for past, current, and future information about these matters. Also, if the Examiner cannot readily access these file histories, the Applicant would be pleased to provide any portion of any of the file histories at any time upon specific Examiner request.

No Disclaimers

To the extent that anything in the Information Disclosure Statement or the listed references could be construed as a disclaimer of any subject matter supported by the present application, Applicant hereby rescinds and retracts such disclaimer.

Timing of Disclosure

This Information Disclosure Statement is being filed after receipt of a First Office Action, but before the mailing date of a Final Action and before the mailing date of a Notice of Allowance. This Statement is accompanied by the fees set forth in 37 CFR 1.17(p). The

Application No.: 14/485612
Filing Date: September 12, 2014

Commissioner is hereby authorized to charge any additional fees which may be required or to credit any overpayment to Account No. 11-1410.

Respectfully submitted,
KNOBBE, MARTENS, OLSON & BEAR, LLP

Dated: August 5, 2015

By: /Sean Ambrosius/ _____
Sean Ambrosius
Registration No. 65,290
Attorney of Record
Customer No. 20995
(949) 760-0404

20660934



NOTICE OF ALLOWANCE AND FEE(S) DUE

20995 7590 08/14/2015
KNOBBE MARTENS OLSON & BEAR LLP
2040 MAIN STREET
FOURTEENTH FLOOR
IRVINE, CA 92614

Table with 2 columns: EXAMINER (DIEP, TRUNG T), ART UNIT (2664), PAPER NUMBER (1068)

DATE MAILED: 08/14/2015

Table with 5 columns: APPLICATION NO., FILING DATE, FIRST NAMED INVENTOR, ATTORNEY DOCKET NO., CONFIRMATION NO.

TITLE OF INVENTION: VIDEO CAMERA

Table with 7 columns: APPLN. TYPE, ENTITY STATUS, ISSUE FEE DUE, PUBLICATION FEE DUE, PREV. PAID ISSUE FEE, TOTAL FEE(S) DUE, DATE DUE

THE APPLICATION IDENTIFIED ABOVE HAS BEEN EXAMINED AND IS ALLOWED FOR ISSUANCE AS A PATENT. PROSECUTION ON THE MERITS IS CLOSED. THIS NOTICE OF ALLOWANCE IS NOT A GRANT OF PATENT RIGHTS. THIS APPLICATION IS SUBJECT TO WITHDRAWAL FROM ISSUE AT THE INITIATIVE OF THE OFFICE OR UPON PETITION BY THE APPLICANT. SEE 37 CFR 1.313 AND MPEP 1308.

THE ISSUE FEE AND PUBLICATION FEE (IF REQUIRED) MUST BE PAID WITHIN THREE MONTHS FROM THE MAILING DATE OF THIS NOTICE OR THIS APPLICATION SHALL BE REGARDED AS ABANDONED. THIS STATUTORY PERIOD CANNOT BE EXTENDED. SEE 35 U.S.C. 151. THE ISSUE FEE DUE INDICATED ABOVE DOES NOT REFLECT A CREDIT FOR ANY PREVIOUSLY PAID ISSUE FEE IN THIS APPLICATION. IF AN ISSUE FEE HAS PREVIOUSLY BEEN PAID IN THIS APPLICATION (AS SHOWN ABOVE), THE RETURN OF PART B OF THIS FORM WILL BE CONSIDERED A REQUEST TO REAPPLY THE PREVIOUSLY PAID ISSUE FEE TOWARD THE ISSUE FEE NOW DUE.

HOW TO REPLY TO THIS NOTICE:

I. Review the ENTITY STATUS shown above. If the ENTITY STATUS is shown as SMALL or MICRO, verify whether entitlement to that entity status still applies.

If the ENTITY STATUS is the same as shown above, pay the TOTAL FEE(S) DUE shown above.

If the ENTITY STATUS is changed from that shown above, on PART B - FEE(S) TRANSMITTAL, complete section number 5 titled "Change in Entity Status (from status indicated above)".

For purposes of this notice, small entity fees are 1/2 the amount of undiscounted fees, and micro entity fees are 1/2 the amount of small entity fees.

II. PART B - FEE(S) TRANSMITTAL, or its equivalent, must be completed and returned to the United States Patent and Trademark Office (USPTO) with your ISSUE FEE and PUBLICATION FEE (if required). If you are charging the fee(s) to your deposit account, section "4b" of Part B - Fee(s) Transmittal should be completed and an extra copy of the form should be submitted. If an equivalent of Part B is filed, a request to reapply a previously paid issue fee must be clearly made, and delays in processing may occur due to the difficulty in recognizing the paper as an equivalent of Part B.

III. All communications regarding this application must give the application number. Please direct all communications prior to issuance to Mail Stop ISSUE FEE unless advised to the contrary.

IMPORTANT REMINDER: Utility patents issuing on applications filed on or after Dec. 12, 1980 may require payment of maintenance fees. It is patentee's responsibility to ensure timely payment of maintenance fees when due.

PART B - FEE(S) TRANSMITTAL

**Complete and send this form, together with applicable fee(s), to: Mail Mail Stop ISSUE FEE
 Commissioner for Patents
 P.O. Box 1450
 Alexandria, Virginia 22313-1450
 or Fax (571)-273-2885**

INSTRUCTIONS: This form should be used for transmitting the ISSUE FEE and PUBLICATION FEE (if required). Blocks 1 through 5 should be completed where appropriate. All further correspondence including the Patent, advance orders and notification of maintenance fees will be mailed to the current correspondence address as indicated unless corrected below or directed otherwise in Block 1, by (a) specifying a new correspondence address; and/or (b) indicating a separate "FEE ADDRESS" for maintenance fee notifications.

Note: A certificate of mailing can only be used for domestic mailings of the Fee(s) Transmittal. This certificate cannot be used for any other accompanying papers. Each additional paper, such as an assignment or formal drawing, must have its own certificate of mailing or transmission.

CURRENT CORRESPONDENCE ADDRESS (Note: Use Block 1 for any change of address)

20995 7590 08/14/2015
KNOBBE MARTENS OLSON & BEAR LLP
 2040 MAIN STREET
 FOURTEENTH FLOOR
 IRVINE, CA 92614

Certificate of Mailing or Transmission

I hereby certify that this Fee(s) Transmittal is being deposited with the United States Postal Service with sufficient postage for first class mail in an envelope addressed to the Mail Stop ISSUE FEE address above, or being facsimile transmitted to the USPTO (571) 273-2885, on the date indicated below.

(Depositor's name)
(Signature)
(Date)

APPLICATION NO.	FILING DATE	FIRST NAMED INVENTOR	ATTORNEY DOCKET NO.	CONFIRMATION NO.
14/485,612	09/12/2014	James H. Jannard	REDCOM.007C4	1068

TITLE OF INVENTION: VIDEO CAMERA

APPLN. TYPE	ENTITY STATUS	ISSUE FEE DUE	PUBLICATION FEE DUE	PREV. PAID ISSUE FEE	TOTAL FEE(S) DUE	DATE DUE
nonprovisional	UNDISCOUNTED	\$960	\$0	\$0	\$960	11/16/2015

EXAMINER	ART UNIT	CLASS-SUBCLASS
DIEP, TRUNG T	2664	348-014000

<p>1. Change of correspondence address or indication of "Fee Address" (37 CFR 1.363).</p> <p><input type="checkbox"/> Change of correspondence address (or Change of Correspondence Address form PTO/SB/122) attached.</p> <p><input type="checkbox"/> "Fee Address" indication (or "Fee Address" Indication form PTO/SB/47; Rev 03-02 or more recent) attached. Use of a Customer Number is required.</p>	<p>2. For printing on the patent front page, list</p> <p>(1) The names of up to 3 registered patent attorneys or agents OR, alternatively, _____ 1</p> <p>(2) The name of a single firm (having as a member a registered attorney or agent) and the names of up to 2 registered patent attorneys or agents. If no name is listed, no name will be printed. _____ 2</p> <p>_____ 3</p>
---	---

3. ASSIGNEE NAME AND RESIDENCE DATA TO BE PRINTED ON THE PATENT (print or type)

PLEASE NOTE: Unless an assignee is identified below, no assignee data will appear on the patent. If an assignee is identified below, the document has been filed for recordation as set forth in 37 CFR 3.11. Completion of this form is NOT a substitute for filing an assignment.

(A) NAME OF ASSIGNEE _____ (B) RESIDENCE: (CITY and STATE OR COUNTRY) _____

Please check the appropriate assignee category or categories (will not be printed on the patent) : Individual Corporation or other private group entity Government

<p>4a. The following fee(s) are submitted:</p> <p><input type="checkbox"/> Issue Fee</p> <p><input type="checkbox"/> Publication Fee (No small entity discount permitted)</p> <p><input type="checkbox"/> Advance Order - # of Copies _____</p>	<p>4b. Payment of Fee(s): (Please first reapply any previously paid issue fee shown above)</p> <p><input type="checkbox"/> A check is enclosed.</p> <p><input type="checkbox"/> Payment by credit card. Form PTO-2038 is attached.</p> <p><input type="checkbox"/> The director is hereby authorized to charge the required fee(s), any deficiency, or credits any overpayment, to Deposit Account Number _____ (enclose an extra copy of this form).</p>
---	--

5. **Change in Entity Status** (from status indicated above)

Applicant certifying micro entity status. See 37 CFR 1.29

Applicant asserting small entity status. See 37 CFR 1.27

Applicant changing to regular undiscounted fee status.

NOTE: Absent a valid certification of Micro Entity Status (see forms PTO/SB/15A and 15B), issue fee payment in the micro entity amount will not be accepted at the risk of application abandonment.

NOTE: If the application was previously under micro entity status, checking this box will be taken to be a notification of loss of entitlement to micro entity status.

NOTE: Checking this box will be taken to be a notification of loss of entitlement to small or micro entity status, as applicable.

NOTE: This form must be signed in accordance with 37 CFR 1.31 and 1.33. See 37 CFR 1.4 for signature requirements and certifications.

Authorized Signature _____ Date _____

Typed or printed name _____ Registration No. _____



UNITED STATES DEPARTMENT OF COMMERCE
United States Patent and Trademark Office
Address: COMMISSIONER FOR PATENTS
P.O. Box 1450
Alexandria, Virginia 22313-1450
www.uspto.gov

APPLICATION NO.	FILING DATE	FIRST NAMED INVENTOR	ATTORNEY DOCKET NO.	CONFIRMATION NO.
14/485,612	09/12/2014	James H. Jannard	REDCOM.007C4	1068

20995 7590 08/14/2015
KNOBBE MARTENS OLSON & BEAR LLP
2040 MAIN STREET
FOURTEENTH FLOOR
IRVINE, CA 92614

EXAMINER

DIEP, TRUNG T

ART UNIT PAPER NUMBER

2664

DATE MAILED: 08/14/2015

Determination of Patent Term Adjustment under 35 U.S.C. 154 (b)
(Applications filed on or after May 29, 2000)

The Office has discontinued providing a Patent Term Adjustment (PTA) calculation with the Notice of Allowance.

Section 1(h)(2) of the AIA Technical Corrections Act amended 35 U.S.C. 154(b)(3)(B)(i) to eliminate the requirement that the Office provide a patent term adjustment determination with the notice of allowance. See Revisions to Patent Term Adjustment, 78 Fed. Reg. 19416, 19417 (Apr. 1, 2013). Therefore, the Office is no longer providing an initial patent term adjustment determination with the notice of allowance. The Office will continue to provide a patent term adjustment determination with the Issue Notification Letter that is mailed to applicant approximately three weeks prior to the issue date of the patent, and will include the patent term adjustment on the patent. Any request for reconsideration of the patent term adjustment determination (or reinstatement of patent term adjustment) should follow the process outlined in 37 CFR 1.705.

Any questions regarding the Patent Term Extension or Adjustment determination should be directed to the Office of Patent Legal Administration at (571)-272-7702. Questions relating to issue and publication fee payments should be directed to the Customer Service Center of the Office of Patent Publication at 1-(888)-786-0101 or (571)-272-4200.

OMB Clearance and PRA Burden Statement for PTOL-85 Part B

The Paperwork Reduction Act (PRA) of 1995 requires Federal agencies to obtain Office of Management and Budget approval before requesting most types of information from the public. When OMB approves an agency request to collect information from the public, OMB (i) provides a valid OMB Control Number and expiration date for the agency to display on the instrument that will be used to collect the information and (ii) requires the agency to inform the public about the OMB Control Number's legal significance in accordance with 5 CFR 1320.5(b).

The information collected by PTOL-85 Part B is required by 37 CFR 1.311. The information is required to obtain or retain a benefit by the public which is to file (and by the USPTO to process) an application. Confidentiality is governed by 35 U.S.C. 122 and 37 CFR 1.14. This collection is estimated to take 12 minutes to complete, including gathering, preparing, and submitting the completed application form to the USPTO. Time will vary depending upon the individual case. Any comments on the amount of time you require to complete this form and/or suggestions for reducing this burden, should be sent to the Chief Information Officer, U.S. Patent and Trademark Office, U.S. Department of Commerce, P.O. Box 1450, Alexandria, Virginia 22313-1450. DO NOT SEND FEES OR COMPLETED FORMS TO THIS ADDRESS. SEND TO: Commissioner for Patents, P.O. Box 1450, Alexandria, Virginia 22313-1450. Under the Paperwork Reduction Act of 1995, no persons are required to respond to a collection of information unless it displays a valid OMB control number.

Privacy Act Statement

The Privacy Act of 1974 (P.L. 93-579) requires that you be given certain information in connection with your submission of the attached form related to a patent application or patent. Accordingly, pursuant to the requirements of the Act, please be advised that: (1) the general authority for the collection of this information is 35 U.S.C. 2(b)(2); (2) furnishing of the information solicited is voluntary; and (3) the principal purpose for which the information is used by the U.S. Patent and Trademark Office is to process and/or examine your submission related to a patent application or patent. If you do not furnish the requested information, the U.S. Patent and Trademark Office may not be able to process and/or examine your submission, which may result in termination of proceedings or abandonment of the application or expiration of the patent.

The information provided by you in this form will be subject to the following routine uses:

1. The information on this form will be treated confidentially to the extent allowed under the Freedom of Information Act (5 U.S.C. 552) and the Privacy Act (5 U.S.C. 552a). Records from this system of records may be disclosed to the Department of Justice to determine whether disclosure of these records is required by the Freedom of Information Act.
2. A record from this system of records may be disclosed, as a routine use, in the course of presenting evidence to a court, magistrate, or administrative tribunal, including disclosures to opposing counsel in the course of settlement negotiations.
3. A record in this system of records may be disclosed, as a routine use, to a Member of Congress submitting a request involving an individual, to whom the record pertains, when the individual has requested assistance from the Member with respect to the subject matter of the record.
4. A record in this system of records may be disclosed, as a routine use, to a contractor of the Agency having need for the information in order to perform a contract. Recipients of information shall be required to comply with the requirements of the Privacy Act of 1974, as amended, pursuant to 5 U.S.C. 552a(m).
5. A record related to an International Application filed under the Patent Cooperation Treaty in this system of records may be disclosed, as a routine use, to the International Bureau of the World Intellectual Property Organization, pursuant to the Patent Cooperation Treaty.
6. A record in this system of records may be disclosed, as a routine use, to another federal agency for purposes of National Security review (35 U.S.C. 181) and for review pursuant to the Atomic Energy Act (42 U.S.C. 218(c)).
7. A record from this system of records may be disclosed, as a routine use, to the Administrator, General Services, or his/her designee, during an inspection of records conducted by GSA as part of that agency's responsibility to recommend improvements in records management practices and programs, under authority of 44 U.S.C. 2904 and 2906. Such disclosure shall be made in accordance with the GSA regulations governing inspection of records for this purpose, and any other relevant (i.e., GSA or Commerce) directive. Such disclosure shall not be used to make determinations about individuals.
8. A record from this system of records may be disclosed, as a routine use, to the public after either publication of the application pursuant to 35 U.S.C. 122(b) or issuance of a patent pursuant to 35 U.S.C. 151. Further, a record may be disclosed, subject to the limitations of 37 CFR 1.14, as a routine use, to the public if the record was filed in an application which became abandoned or in which the proceedings were terminated and which application is referenced by either a published application, an application open to public inspection or an issued patent.
9. A record from this system of records may be disclosed, as a routine use, to a Federal, State, or local law enforcement agency, if the USPTO becomes aware of a violation or potential violation of law or regulation.

Notice of Allowability	Application No. 14/485,612	Applicant(s) JANNARD ET AL.	
	Examiner TRUNG DIEP	Art Unit 2664	AIA (First Inventor to File) Status No

-- The MAILING DATE of this communication appears on the cover sheet with the correspondence address--

All claims being allowable, PROSECUTION ON THE MERITS IS (OR REMAINS) CLOSED in this application. If not included herewith (or previously mailed), a Notice of Allowance (PTOL-85) or other appropriate communication will be mailed in due course. **THIS NOTICE OF ALLOWABILITY IS NOT A GRANT OF PATENT RIGHTS.** This application is subject to withdrawal from issue at the initiative of the Office or upon petition by the applicant. See 37 CFR 1.313 and MPEP 1308.

1. This communication is responsive to supplemental response filed 08/03/2015.
 A declaration(s)/affidavit(s) under **37 CFR 1.130(b)** was/were filed on _____.
2. An election was made by the applicant in response to a restriction requirement set forth during the interview on _____; the restriction requirement and election have been incorporated into this action.
3. The allowed claim(s) is/are 1-30. As a result of the allowed claim(s), you may be eligible to benefit from the **Patent Prosecution Highway** program at a participating intellectual property office for the corresponding application. For more information, please see http://www.uspto.gov/patents/init_events/pph/index.jsp or send an inquiry to PPHfeedback@uspto.gov.
4. Acknowledgment is made of a claim for foreign priority under 35 U.S.C. § 119(a)-(d) or (f).

Certified copies:

- a) All b) Some *c) None of the:
1. Certified copies of the priority documents have been received.
 2. Certified copies of the priority documents have been received in Application No. _____.
 3. Copies of the certified copies of the priority documents have been received in this national stage application from the International Bureau (PCT Rule 17.2(a)).
- * Certified copies not received: _____.

Applicant has **THREE MONTHS FROM THE "MAILING DATE"** of this communication to file a reply complying with the requirements noted below. Failure to timely comply will result in **ABANDONMENT** of this application.
THIS THREE-MONTH PERIOD IS NOT EXTENDABLE.

5. CORRECTED DRAWINGS (as "replacement sheets") must be submitted.
 including changes required by the attached Examiner's Amendment / Comment or in the Office action of Paper No./Mail Date _____.
Identifying indicia such as the application number (see 37 CFR 1.84(c)) should be written on the drawings in the front (not the back) of each sheet. Replacement sheet(s) should be labeled as such in the header according to 37 CFR 1.121(d).
6. DEPOSIT OF and/or INFORMATION about the deposit of **BIOLOGICAL MATERIAL** must be submitted. Note the attached Examiner's comment regarding **REQUIREMENT FOR THE DEPOSIT OF BIOLOGICAL MATERIAL**.

Attachment(s)

- | | |
|--|--|
| 1. <input checked="" type="checkbox"/> Notice of References Cited (PTO-892) | 5. <input type="checkbox"/> Examiner's Amendment/Comment |
| 2. <input checked="" type="checkbox"/> Information Disclosure Statements (PTO/SB/08),
Paper No./Mail Date _____ | 6. <input checked="" type="checkbox"/> Examiner's Statement of Reasons for Allowance |
| 3. <input type="checkbox"/> Examiner's Comment Regarding Requirement for Deposit
of Biological Material | 7. <input type="checkbox"/> Other _____. |
| 4. <input checked="" type="checkbox"/> Interview Summary (PTO-413),
Paper No./Mail Date _____. | |

1. The present application is being examined under the pre-AIA first to invent provisions.

DETAILED ACTION

Terminal Disclaimer

2. The terminal disclaimer filed on 8/03/2015 disclaiming the terminal portion of any patent granted on this application which would extend beyond the expiration date of the full statutory term prior application No. 14/485,611 has been reviewed and is accepted. The terminal disclaimer has been recorded.

Information Disclosure Statement

3. The information disclosure statement (IDS) submitted on 05/18/2015 and 08/05/2015 is in compliance with the provisions of 37 CFR 1.97. Accordingly, the information disclosure statement is being considered by the examiner.

Allowable Subject Matter

4. Claims 1-30 are allowed.

The Examiner's statement of reasons for allowance has been stated in the Applicant remarks filed on 05/18/2015 and supplemental amendments filed on 08/03/2015.

Conclusion

Any inquiry concerning this communication or earlier communications from the examiner should be directed to TRUNG DIEP whose telephone number is (571)270-5088. The examiner can normally be reached on Mon.,- Thur., 8:00 am,-5:00 p.m. EST.

Art Unit: 2664

If attempts to reach the examiner by telephone are unsuccessful, the examiner's supervisor, Lin Ye can be reached on (571) 272-7372. The fax phone number for the organization where this application or proceeding is assigned is 571-273-8300.

Information regarding the status of an application may be obtained from the Patent Application Information Retrieval (PAIR) system. Status information for published applications may be obtained from either Private PAIR or Public PAIR. Status information for unpublished applications is available through Private PAIR only. For more information about the PAIR system, see <http://pair-direct.uspto.gov>. Should you have questions on access to the Private PAIR system, contact the Electronic Business Center (EBC) at 866-217-9197 (toll-free). If you would like assistance from a USPTO Customer Service Representative or access to the automated information system, call 800-786-9199 (IN USA OR CANADA) or 571-272-1000.

/TRUNG DIEP/
Primary Examiner, Art Unit 2664

Examiner-Initiated Interview Summary	Application No. 14/485,612	Applicant(s) JANNARD ET AL.	
	Examiner TRUNG DIEP	Art Unit 2664	

All participants (applicant, applicant's representative, PTO personnel):

- (1) TRUNG DIEP. (3)_____.
- (2) Attorney Micheal Guilliana. (4)_____.

Date of Interview: 31 July 2015.

Type: Telephonic Video Conference
 Personal [copy given to: applicant applicant's representative]

Exhibit shown or demonstration conducted: Yes No.
If Yes, brief description: _____.

Issues Discussed 101 112 102 103 Others
(For each of the checked box(es) above, please describe below the issue and detailed description of the discussion)

Claim(s) discussed: N/A.

Identification of prior art discussed: N/A.

Substance of Interview

(For each issue discussed, provide a detailed description and indicate if agreement was reached. Some topics may include: identification or clarification of a reference or a portion thereof, claim interpretation, proposed amendments, arguments of any applied references etc...)

The phone-interview was conducted between Examiner Diep and Attorney Guilliana on 07/31/2015. Discussion included the request for filing the terminal disclaimer (TD) for this application. The attorney informed Examiner that the TD would be filed as early as Monday next week..

Applicant recordation instructions: It is not necessary for applicant to provide a separate record of the substance of interview.

Examiner recordation instructions: Examiners must summarize the substance of any interview of record. A complete and proper recordation of the substance of an interview should include the items listed in MPEP 713.04 for complete and proper recordation including the identification of the general thrust of each argument or issue discussed, a general indication of any other pertinent matters discussed regarding patentability and the general results or outcome of the interview, to include an indication as to whether or not agreement was reached on the issues raised.

Attachment

/TRUNG DIEP/
Primary Examiner, Art Unit 2664

Notice of References Cited	Application/Control No. 14/485,612	Applicant(s)/Patent Under Reexamination JANNARD ET AL.	
	Examiner TRUNG DIEP	Art Unit 2664	Page 1 of 1

U.S. PATENT DOCUMENTS

*	Document Number Country Code-Number-Kind Code	Date MM-YYYY	Name	Classification
*	A US-7,898,575 B2	03-2011	Ishii, Kensuke	348/222.1
*	B US-8,014,597 B1	09-2011	Newman, David A.	382/166
	C US-			
	D US-			
	E US-			
	F US-			
	G US-			
	H US-			
	I US-			
	J US-			
	K US-			
	L US-			
	M US-			

FOREIGN PATENT DOCUMENTS

*	Document Number Country Code-Number-Kind Code	Date MM-YYYY	Country	Name	Classification
	N				
	O				
	P				
	Q				
	R				
	S				
	T				

NON-PATENT DOCUMENTS

*	Document Number Country Code-Number-Kind Code	Date MM-YYYY	Country	Name	Classification
	Include as applicable: Author, Title Date, Publisher, Edition or Volume, Pertinent Pages)				
	U				
	V				
	W				
	X				

*A copy of this reference is not being furnished with this Office action. (See MPEP § 707.05(a).)
Dates in MM-YYYY format are publication dates. Classifications may be US or foreign.

Issue Classification 	Application/Control No. 14485612	Applicant(s)/Patent Under Reexamination JANNARD ET AL.	
	Examiner TRUNG DIEP	Art Unit 2664	

CPC						
Symbol					Type	Version
G06T		3		4015	F	2013-01-01
H04N		1		648	I	2013-01-01
H04N		9		045	I	2013-01-01
H04N		19		186	I	2014-11-01
H04N		19		85	I	2014-11-01
G11B		27		031	I	2013-01-01
H04N		5		2252	I	2013-01-01
H04N		5		374	I	2013-01-01
H04N		5		772	I	2013-01-01
H04N		19		91	I	2014-11-01

CPC Combination Sets				
Symbol	Type	Set	Ranking	Version

NONE		Total Claims Allowed:	
(Assistant Examiner)		30	
(Date)			
/TRUNG DIEP/ Primary Examiner. Art Unit 2664	08/06/2015	O.G. Print Claim(s)	O.G. Print Figure
(Primary Examiner)	(Date)	1	8

Issue Classification 	Application/Control No. 14485612	Applicant(s)/Patent Under Reexamination JANNARD ET AL.
	Examiner TRUNG DIEP	Art Unit 2664

US ORIGINAL CLASSIFICATION					INTERNATIONAL CLASSIFICATION												
CLASS		SUBCLASS			CLAIMED					NON-CLAIMED							
348		222.1			H	0	4	N	5 / 228 (2006.0)								
CROSS REFERENCE(S)					H	0	4	N	9 / 73 (2006.0)								
					G	0	6	K	9 / 36 (2006.01.01)								
CLASS	SUBCLASS (ONE SUBCLASS PER BLOCK)																
348	223.1																
382	166																

NONE		Total Claims Allowed:	
(Assistant Examiner)		30	
(Date)			
/TRUNG DIEP/ Primary Examiner. Art Unit 2664		O.G. Print Claim(s)	O.G. Print Figure
(Primary Examiner)		1	8
(Date)		08/06/2015	

Issue Classification 	Application/Control No. 14485612	Applicant(s)/Patent Under Reexamination JANNARD ET AL.
	Examiner TRUNG DIEP	Art Unit 2664

<input checked="" type="checkbox"/> Claims renumbered in the same order as presented by applicant <input type="checkbox"/> CPA <input checked="" type="checkbox"/> T.D. <input type="checkbox"/> R.1.47															
Final	Original	Final	Original	Final	Original	Final	Original	Final	Original	Final	Original	Final	Original	Final	Original
	1		17												
	2		18												
	3		19												
	4		20												
	5		21												
	6		22												
	7		23												
	8		24												
	9		25												
	10		26												
	11		27												
	12		28												
	13		29												
	14		30												
	15														
	16														

NONE		Total Claims Allowed:	
		30	
(Assistant Examiner)	(Date)	O.G. Print Claim(s)	O.G. Print Figure
/TRUNG DIEP/ Primary Examiner. Art Unit 2664	08/06/2015	1	8
(Primary Examiner)	(Date)		

Search Notes 	Application/Control No. 14485612	Applicant(s)/Patent Under Reexamination JANNARD ET AL.
	Examiner TRUNG DIEP	Art Unit 2664

CPC- SEARCHED		
Symbol	Date	Examiner
(G08B13/19628 OR H04N9/43 OR G06T7/2006 OR H04N9/045 OR H04N2209/046 OR H04N5/23235 OR H04N13/0257 OR G06T3/4015 OR G06T9/007 OR H04N19/00315 OR H04N19/00763 OR H04N19/00903 OR H04N1/648 OR H04N5/225	11/10/2014	TD

CPC COMBINATION SETS - SEARCHED		
Symbol	Date	Examiner

US CLASSIFICATION SEARCHED			
Class	Subclass	Date	Examiner
348	240.2, 222.1, 223.1, 273-280.	11/10/2014	TD
375	240.2, 240.25, 240.26 and 340.29.	11/10/2014	TD
382	166-167.	11/10/2014	TD

SEARCH NOTES		
Search Notes	Date	Examiner
EAST searched.	11/10/2014	TD
Combined text with US subclasses searched.	11/10/2014	TD
Combined text with US subgroups searched.	11/10/2014	TD
Parent case (13/464,803), its continuity and references checked.	11/10/2014	TD
Inventorship searched.	8/6/2015	TD
Copending application double patenting searched.	8/6/2015	TD
Text searched -- See search history.	8/6/2015	TD

INTERFERENCE SEARCH			
US Class/ CPC Symbol	US Subclass / CPC Group	Date	Examiner
All	PGPUB text searched.	8/6/2015	TD

--	--

INFORMATION DISCLOSURE STATEMENT BY APPLICANT	Application No.	14/485612
	Filing Date	September 12, 2014
	First Named Inventor	James H. Jannard
	Art Unit	2664
<i>(Multiple sheets used when necessary)</i>	Examiner	Diep, Trung T.
SHEET 1 OF 1	Attorney Docket No.	REDCOM.007C4

U.S. PATENT DOCUMENTS						
Examiner Initials	Cite No.	Document Number <i>Number - Kind Code (if known)</i> Example: 1,234,567 B1	Publication Date MM-DD-YYYY	Name	Pages, Columns, Lines Where Relevant Passages or Relevant Figures Appear	
FOREIGN PATENT DOCUMENTS						
Examiner Initials	Cite No.	Foreign Patent Document <i>Country Code-Number-Kind Code</i> Example: JP 1234567 A1	Publication Date MM-DD-YYYY	Name	Pages, Columns, Lines Where Relevant Passages or Relevant Figures Appear	T ¹

NON PATENT LITERATURE DOCUMENTS			
Examiner Initials	Cite No.	Include name of the author (in CAPITAL LETTERS), title of the article (when appropriate), title of the item (book, magazine, journal, serial, symposium, catalog, etc.), date, page(s), volume-issue number(s), publisher, city and/or country where published.	T ¹
/T.D./	1	Official Communication in Korean Application No. 10-2014-7021892 (REDCOM.007VKRD1), dated October 10, 2014.	X

20660190

Examiner Signature	/Trung Diep/	Date Considered	08/06/2015
<p>*Examiner: Initial if reference considered, whether or not citation is in conformance with MPEP 609. Draw line through citation if not in conformance and not considered. Include copy of this form with next communication to applicant.</p>			

T¹ - Place a check mark in this area when an English language Translation is attached.

INFORMATION DISCLOSURE STATEMENT BY APPLICANT	Application No.	14/485612
	Filing Date	September 12, 2014
	First Named Inventor	James H. Jannard
	Art Unit	2664
<i>(Multiple sheets used when necessary)</i>	Examiner	Diep, Trung T.
SHEET 1 OF 2	Attorney Docket No.	REDCOM.007C4

U.S. PATENT DOCUMENTS					
Examiner Initials	Cite No.	Document Number <i>Number - Kind Code (if known)</i> Example: 1,234,567 B1	Publication Date MM-DD-YYYY	Name	Pages, Columns, Lines Where Relevant Passages or Relevant Figures Appear
/T.D./	1	5,132,803	07-21-1992	Suga et al.	
/T.D./	2	5,172,227	12-15-1992	Tsai et al.	
/T.D./	3	5,412,427	05-02-1995	Rabbani et al.	
/T.D./	4	6,169,317	01-02-2001	Sawada et al.	
/T.D./	5	6,878,977	04-12-2005	Kozuka et al.	
/T.D./	6	7,902,512	03-08-2011	Chang et al.	
/T.D./	7	7,952,636	05-31-2011	Ikeda et al.	
/T.D./	8	8,125,547	02-28-2012	Oda et al.	
/T.D./	9	8,477,173	07-02-2013	Kenoyer	
/T.D./	10	8,792,029	07-29-2014	Lee	
/T.D./	11	8,817,141	08-26-2014	Tanaka	
/T.D./	12	8,872,933 (and entire prosecution history) (REDCOM.007C1)	10-28-2014	Jannard et al.	
/T.D./	13	8,878,952 (and entire prosecution history) (REDCOM.007CP1C2)	11-04-2014	Jannard et al.	
/T.D./	14	9,019,393 (and entire prosecution history) (REDCOM.007P1C3)	04-28-2015	Jannard et al.	
/T.D./	15	2001/0048477	12-06-2001	Misawa	
/T.D./	16	2002/0039142	04-04-2002	Zhang et al.	
/T.D./	17	2002/0167602	11-14-2002	Nguyen	
/T.D./	18	2004/0201760	10-14-2004	Ota et al.	
/T.D./	19	2005/0041116	02-24-2005	Tsukioka	
/T.D./	20	2007/0133902	06-14-2007	Kumar	
/T.D./	21	2007/0164335	07-19-2007	McKee	
/T.D./	22	2008/0012953	01-17-2008	Yang et al.	
/T.D./	23	2008/0063269	03-13-2008	Chiu	
/T.D./	24	2008/0285871	11-20-2008	Ishikawa	
/T.D./	25	2009/0033752	02-05-2009	Bodnar et al.	
/T.D./	26	2009/0086817	04-02-2009	Matsuoka et al.	

Examiner Signature	/Trung Diep/	Date Considered	/T.D./
<p>*Examiner: Initial if reference considered, whether or not citation is in conformance with MPEP 609. Draw line through citation if not in conformance and not considered. Include copy of this form with next communication to applicant.</p>			

T¹ - Place a check mark in this area when an English language Translation is attached.

INFORMATION DISCLOSURE STATEMENT BY APPLICANT	Application No.	14/485612
	Filing Date	September 12, 2014
	First Named Inventor	James H. Jannard
	Art Unit	2664
<i>(Multiple sheets used when necessary)</i>	Examiner	Diep, Trung T.
SHEET 2 OF 2	Attorney Docket No.	REDCOM.007C4

U.S. PATENT DOCUMENTS					
Examiner Initials	Cite No.	Document Number <i>Number - Kind Code (if known)</i> Example: 1,234,567 B1	Publication Date MM-DD-YYYY	Name	Pages, Columns, Lines Where Relevant Passages or Relevant Figures Appear
/T.D./	27	2010/0225795	09-09-2010	Suzuki et al.	
/T.D./	28	2011/0194763	08-11-2011	Moon et al.	
/T.D./	29	2014/0063297	03-06-2014	Yamura	
/T.D./	30	2014/0161367	06-12-2014	Ridenour et al.	
/T.D./	31	2014/0218580	08-07-2014	Mayer et al.	
/T.D./	32	2014/0333810	11-13-2014	Nakaseko	
/T.D./	33	2015/0003801 (and entire prosecution history) (REDCOM.007C3)	01-01-2015	Jannard et al.	
/T.D./	34	2015/0092094	04-02-2015	Itonaga et al.	

FOREIGN PATENT DOCUMENTS						
Examiner Initials	Cite No.	Foreign Patent Document <i>Country Code-Number-Kind Code</i> Example: JP 1234567 A1	Publication Date MM-DD-YYYY	Name	Pages, Columns, Lines Where Relevant Passages or Relevant Figures Appear	T ¹
/T.D./	35	CA 2 831 698	10-23-2008	Red.com, Inc.		
/T.D./	36	CN 101689357	03-04-2015	Red.com, Inc.		X
/T.D./	37	JP 2008-124976	05-29-2008	Fujitsu Ltd.		X
/T.D./	38	KR 10-1478380	12-24-2014	Red.com, Inc.		X
/T.D./	39	WO 99/012345	03-11-1999	Intel Corporation		

NON PATENT LITERATURE DOCUMENTS			
Examiner Initials	Cite No.	Include name of the author (in CAPITAL LETTERS), title of the article (when appropriate), title of the item (book, magazine, journal, serial, symposium, catalog, etc.), date, page(s), volume-issue number(s), publisher, city and/or country where published.	T ¹
/T.D./	40	Notice of Opposition in European Application No. 08745686.9 (REDCOM.007VEP), dated April 22, 2015.	
/T.D./	41	Official Communication in Korean Application No. 10-2014-7021892 (REDCOM.007VKRD1), dated October 10, 2014.	X

20660190

Examiner Signature	/Trung Diep/	Date Considered	08/05/2015
--------------------	--------------	-----------------	------------

***Examiner:** Initial if reference considered, whether or not citation is in conformance with MPEP 609. Draw line through citation if not in conformance and not considered. Include copy of this form with next communication to applicant.

T¹ - Place a check mark in this area when an English language Translation is attached.



UNITED STATES PATENT AND TRADEMARK OFFICE

UNITED STATES DEPARTMENT OF COMMERCE
 United States Patent and Trademark Office
 Address: COMMISSIONER FOR PATENTS
 P.O. Box 1450
 Alexandria, Virginia 22313-1450
 www.uspto.gov

BIB DATA SHEET

CONFIRMATION NO. 1068

SERIAL NUMBER 14/485,612	FILING or 371(c) DATE 09/12/2014 RULE	CLASS 348	GROUP ART UNIT 2664	ATTORNEY DOCKET NO. REDCOM.007C4	
APPLICANTS RED.COM, INC., Irvine, CA; INVENTORS James H. Jannard, Las Vegas, NV; Thomas Graeme Nattress, Acton, CANADA; ** CONTINUING DATA ***** This application is a CON of 13/464,803 05/04/2012 PAT 8872933 which is a CON of 12/101,882 04/11/2008 PAT 8174560 which claims benefit of 60/911,196 04/11/2007 and claims benefit of 61/017,406 12/28/2007 ** FOREIGN APPLICATIONS ***** ** IF REQUIRED, FOREIGN FILING LICENSE GRANTED ** 09/18/2014					
Foreign Priority claimed <input type="checkbox"/> Yes <input checked="" type="checkbox"/> No 35 USC 119(a-d) conditions met <input type="checkbox"/> Yes <input checked="" type="checkbox"/> No Verified and Acknowledged <u> </u> /TRUNG T DIEP/ Examiner's Signature	<input type="checkbox"/> Met after Allowance Initials <u> </u>	STATE OR COUNTRY NV	SHEETS DRAWINGS 18	TOTAL CLAIMS 30	INDEPENDENT CLAIMS 2
ADDRESS KNOBBE MARTENS OLSON & BEAR LLP 2040 MAIN STREET FOURTEENTH FLOOR IRVINE, CA 92614 UNITED STATES					
TITLE VIDEO CAMERA					
FILING FEE RECEIVED 2540	FEES: Authority has been given in Paper No. _____ to charge/credit DEPOSIT ACCOUNT No. _____ for following:	<input type="checkbox"/> All Fees <input type="checkbox"/> 1.16 Fees (Filing) <input type="checkbox"/> 1.17 Fees (Processing Ext. of time) <input type="checkbox"/> 1.18 Fees (Issue) <input type="checkbox"/> Other _____ <input type="checkbox"/> Credit			

EAST Search History

EAST Search History (Prior Art)

Ref #	Hits	Search Query	DBs	Default Operator	Plurals	Time Stamp
S44	0	((video or motion or mov\$3 adj image) and compress\$3 and (raw adj data) and (2K or 4K adj camera)).CLM.	US-PGPUB; USPAT	OR	OFF	2015/08/06 12:15
S45	0	((video or motion or mov\$3 adj image) and compress\$3 and (raw adj data) and (2K or 4K adj camera)).CLM.	US-PGPUB	OR	OFF	2015/08/06 12:16
S46	12	((video or motion or mov\$3 adj image) and compress\$3 and (2K or 4K adj camera)).CLM.	US-PGPUB; USPAT	OR	OFF	2015/08/06 12:17
S47	3	((video or motion or mov\$3 adj image) and compress\$3 and (2K or 4K adj camera)).CLM.	US-PGPUB	OR	OFF	2015/08/06 12:19
S48	0	((2K or 4K adj resolution) and compress\$3 and (raw adj data) and (movie or cinema adj camera)).CLM.	US-PGPUB; USPAT	OR	OFF	2015/08/06 12:21
S49	0	((2K or 4K adj resolution) and compress\$3 and (raw adj data) and (movie or cinema adj camera)).CLM.	US-PGPUB	OR	OFF	2015/08/06 12:21
S50	0	((video or motion or mov\$3 adj image) and (mathematica\$3 adj compress\$3) and (raw adj data) and (2K or 4K adj camera)).CLM.	US-PGPUB; USPAT	OR	OFF	2015/08/06 12:22
S51	0	((video or motion or mov\$3 adj image) and (mathematica\$3 adj compress\$3) and (raw adj data) and (2K or 4K adj camera)).CLM.	US-PGPUB	OR	OFF	2015/08/06 12:22
S52	0	((video or motion or mov\$3 adj image) and compress\$3 and (raw adj data) and (2K or 4K adj resolution)).CLM.	US-PGPUB; USPAT	OR	OFF	2015/08/06 12:26
S53	0	((video or motion or mov\$3 adj image) and compress\$3 and (raw adj data) and (2K or 4K adj resolution)).CLM.	US-PGPUB	OR	OFF	2015/08/06 12:26
S54	1	((video or motion or mov\$3 adj image) and (raw adj data) and (2K or 4K adj resolution)).CLM.	US-PGPUB; USPAT	OR	OFF	2015/08/06 12:27
S55	1	((video or motion or mov\$3 adj image) and (raw adj data) and (2K or 4K adj resolution)).CLM.	US-PGPUB	OR	OFF	2015/08/06 12:28
S56	320	((James) near2 (Jannard)).INV.	US-PGPUB; USPAT; USOCR	OR	OFF	2015/08/06 12:28

8/ 6/ 2015 12:37:34 PM

C:\Users\tdiep\Documents\EAST\Workspaces\14485612.wsp

INFORMATION DISCLOSURE STATEMENT BY APPLICANT	Application No.	14/485612
	Filing Date	September 12, 2014
	First Named Inventor	James H. Jannard
	Art Unit	2664
<i>(Multiple sheets used when necessary)</i>	Examiner	Diep, Trung T.
SHEET 1 OF 1	Attorney Docket No.	REDCOM.007C4

U.S. PATENT DOCUMENTS						
Examiner Initials	Cite No.	Document Number <i>Number - Kind Code (if known)</i> Example: 1,234,567 B1	Publication Date MM-DD-YYYY	Name	Pages, Columns, Lines Where Relevant Passages or Relevant Figures Appear	
	1	7,480,417	01-20-2009	Malvar		

FOREIGN PATENT DOCUMENTS						
Examiner Initials	Cite No.	Foreign Patent Document <i>Country Code-Number-Kind Code</i> Example: JP 1234567 A1	Publication Date MM-DD-YYYY	Name	Pages, Columns, Lines Where Relevant Passages or Relevant Figures Appear	T ¹
	2	CN 104702926	06-10-2015	Red.com, Inc.		X

NON PATENT LITERATURE DOCUMENTS			
Examiner Initials	Cite No.	Include name of the author (in CAPITAL LETTERS), title of the article (when appropriate), title of the item (book, magazine, journal, serial, symposium, catalog, etc.), date, page(s), volume-issue number(s), publisher, city and/or country where published.	T ¹
	3	Official Communication in European Application No. 14177071.9 (REDCOM.007VEPD1), dated July 30, 2015.	
	4	Examination Report in New Zealand Application No. 710813 (REDCOM.007NZD3), dated August 12, 2015.	
	5	Official Communication in Taiwanese Application No. 99111497 (REDCOM.007QTW), dated July 24, 2015.	X
	6	International Preliminary Report on Patentability and Written Opinion in PCT Application No. PCT/US2014/016301 (REDCOM.084WO), dated August 27, 2015.	

21659542

Examiner Signature	Date Considered
<p>*Examiner: Initial if reference considered, whether or not citation is in conformance with MPEP 609. Draw line through citation if not in conformance and not considered. Include copy of this form with next communication to applicant.</p>	

T¹ - Place a check mark in this area when an English language Translation is attached.

**REQUEST FOR CONTINUED EXAMINATION(RCE)TRANSMITTAL
(Submitted Only via EFS-Web)**

Application Number	14485612	Filing Date	2014-09-12	Docket Number (if applicable)	REDCOM.007C4	Art Unit	2664
First Named Inventor	Jannard, James H.			Examiner Name	Diep, Trung T.		

This is a Request for Continued Examination (RCE) under 37 CFR 1.114 of the above-identified application.
Request for Continued Examination (RCE) practice under 37 CFR 1.114 does not apply to any utility or plant application filed prior to June 8, 1995, to any international application that does not comply with the requirements of 35 U.S.C. 371, or to any design application. The Instruction Sheet for this form is located at WWW.USPTO.GOV.

SUBMISSION REQUIRED UNDER 37 CFR 1.114

Note: If the RCE is proper, any previously filed unentered amendments and amendments enclosed with the RCE will be entered in the order in which they were filed unless applicant instructs otherwise. If applicant does not wish to have any previously filed unentered amendment(s) entered, applicant must request non-entry of such amendment(s).

Previously submitted. If a final Office action is outstanding, any amendments filed after the final Office action may be considered as a submission even if this box is not checked.

Consider the arguments in the Appeal Brief or Reply Brief previously filed on _____

Other _____

Enclosed

Amendment/Reply

Information Disclosure Statement (IDS)

Affidavit(s)/ Declaration(s)

Other _____

MISCELLANEOUS

Suspension of action on the above-identified application is requested under 37 CFR 1.103(c) for a period of months _____
(Period of suspension shall not exceed 3 months; Fee under 37 CFR 1.17(i) required)

Other _____

FEES

The RCE fee under 37 CFR 1.17(e) is required by 37 CFR 1.114 when the RCE is filed.

The Director is hereby authorized to charge any underpayment of fees, or credit any overpayments, to Deposit Account No 111410

SIGNATURE OF APPLICANT, ATTORNEY, OR AGENT REQUIRED

Patent Practitioner Signature

Applicant Signature

Signature of Registered U.S. Patent Practitioner			
Signature	/Sean Ambrosius/	Date (YYYY-MM-DD)	2015-09-29
Name	Sean Ambrosius	Registration Number	65290

This collection of information is required by 37 CFR 1.114. The information is required to obtain or retain a benefit by the public which is to file (and by the USPTO to process) an application. Confidentiality is governed by 35 U.S.C. 122 and 37 CFR 1.11 and 1.14. This collection is estimated to take 12 minutes to complete, including gathering, preparing, and submitting the completed application form to the USPTO. Time will vary depending upon the individual case. Any comments on the amount of time you require to complete this form and/or suggestions for reducing this burden, should be sent to the Chief Information Officer, U.S. Patent and Trademark Office, U.S. Department of Commerce, P.O. Box 1450, Alexandria, VA 22313-1450.

If you need assistance in completing the form, call 1-800-PTO-9199 and select option 2.

Privacy Act Statement

The Privacy Act of 1974 (P.L. 93-579) requires that you be given certain information in connection with your submission of the attached form related to a patent application or patent. Accordingly, pursuant to the requirements of the Act, please be advised that: (1) the general authority for the collection of this information is 35 U.S.C. 2(b)(2); (2) furnishing of the information solicited is voluntary; and (3) the principal purpose for which the information is used by the U.S. Patent and Trademark Office is to process and/or examine your submission related to a patent application or patent. If you do not furnish the requested information, the U.S. Patent and Trademark Office may not be able to process and/or examine your submission, which may result in termination of proceedings or abandonment of the application or expiration of the patent.

The information provided by you in this form will be subject to the following routine uses:

1. The information on this form will be treated confidentially to the extent allowed under the Freedom of Information Act (5 U.S.C. 552) and the Privacy Act (5 U.S.C. 552a). Records from this system of records may be disclosed to the Department of Justice to determine whether the Freedom of Information Act requires disclosure of these records.
2. A record from this system of records may be disclosed, as a routine use, in the course of presenting evidence to a court, magistrate, or administrative tribunal, including disclosures to opposing counsel in the course of settlement negotiations.
3. A record in this system of records may be disclosed, as a routine use, to a Member of Congress submitting a request involving an individual, to whom the record pertains, when the individual has requested assistance from the Member with respect to the subject matter of the record.
4. A record in this system of records may be disclosed, as a routine use, to a contractor of the Agency having need for the information in order to perform a contract. Recipients of information shall be required to comply with the requirements of the Privacy Act of 1974, as amended, pursuant to 5 U.S.C. 552a(m).
5. A record related to an International Application filed under the Patent Cooperation Treaty in this system of records may be disclosed, as a routine use, to the International Bureau of the World Intellectual Property Organization, pursuant to the Patent Cooperation Treaty.
6. A record in this system of records may be disclosed, as a routine use, to another federal agency for purposes of National Security review (35 U.S.C. 181) and for review pursuant to the Atomic Energy Act (42 U.S.C. 218(c)).
7. A record from this system of records may be disclosed, as a routine use, to the Administrator, General Services, or his/her designee, during an inspection of records conducted by GSA as part of that agency's responsibility to recommend improvements in records management practices and programs, under authority of 44 U.S.C. 2904 and 2906. Such disclosure shall be made in accordance with the GSA regulations governing inspection of records for this purpose, and any other relevant (i.e., GSA or Commerce) directive. Such disclosure shall not be used to make determinations about individuals.
8. A record from this system of records may be disclosed, as a routine use, to the public after either publication of the application pursuant to 35 U.S.C. 122(b) or issuance of a patent pursuant to 35 U.S.C. 151. Further, a record may be disclosed, subject to the limitations of 37 CFR 1.14, as a routine use, to the public if the record was filed in an application which became abandoned or in which the proceedings were terminated and which application is referenced by either a published application, an application open to public inspections or an issued patent.
9. A record from this system of records may be disclosed, as a routine use, to a Federal, State, or local law enforcement agency, if the USPTO becomes aware of a violation or potential violation of law or regulation.

IN THE UNITED STATES PATENT AND TRADEMARK OFFICE

Inventor	: James H. Jannard
App. No.	: 14/485612
Filed	: September 12, 2014
For	: VIDEO CAMERA
Examiner	: Diep, Trung T.
Art Unit	: 2664
Conf. No.	: 1068

PETITION TO EXPUNGE INFORMATION UNINTENTIONALLY SUBMITTED IN AN
APPLICATION UNDER 37 CFR § 1.59; SUBMITTED WITH REQUEST FOR CONTINUED
EXAMINATION

Mail Stop Petition

Commissioner for Patents
P.O. Box 1450
Alexandria, VA 22313-1450

Pursuant to 37 C.F.R. § 1.59 (b) and M.P.E.P. § 724.05(II), Applicant hereby submits this petition to expunge information unintentionally submitted in the above-referenced application. The petition fee as set forth in 37 C.F.R. 1.17(g) is submitted herewith.

Statement of the Facts Involved

On May 18, 2015, Applicant filed an Information Disclosure Statement at 19:51:33 (EFS ID: 22380024) in Application No. 14/485,612 (“the ‘612 Application”). Applicant submitted a seven page non-patent literature document (“the Submitted Document”) in conjunction with the Information Disclosure Statement. The Submitted Document is listed as Cite No. 41 on the PTO/SB/08 Equivalent, along with the following description: “Official Communication in Korean Application No. 10-2014-7021892 (REDCOM.007VKRD1), dated October 10, 2014”.

It was Applicant’s intention to submit an Official Communication issued by the Korean Intellectual Property Office in Korean Application No. 10-2014-7021892, as well as a translation of the Official Communication. However, it came to the Applicant’s attention that pages 2-4 of the Submitted Document contained unintentionally submitted confidential and proprietary information. In particular, pages 2-4 of the Submitted Document inadvertently included portions of a letter received by Applicant’s attorneys from a Korean law firm assisting with prosecution of the above-referenced Korean patent application. The letter is proprietary material and included

Appl. No. : 14/485,612
Filed : 09/12/2014

confidential comments from the Korean law firm relating to issues relating to the Official Communication.

A similar unintentional disclosure of the same material was made in an IDS submission in co-owned U.S. Application No. 14/488,030 (“the ‘030 application”). On even date herewith Applicant is filing a separate petition to expunge the information submitted in the ‘030 application.

Statement of the Points to be Reviewed

The required contents of a petition under 37 CFR § 1.59(b) to expunge information unintentionally submitted in an application are set forth in M.P.E.P. § 724.05 (II):

- (A) the Office can effect such return prior to issuance of any patent on the application in issue;
- (B) it is stated that the information submitted was unintentionally submitted and the failure to obtain its return would cause irreparable harm to the party who submitted the information or to the party in interest on whose behalf the information was submitted;
- (C) the information has not otherwise been made public;
- (D) there is a commitment on the part of the petitioner to retain such information for the period of any patent with regard to which such information is submitted;
- (E) it is established to the satisfaction of the Director that the information to be returned is not material information under 37 CFR 1.56; and
- (F) the petition fee as set forth in 37 CFR 1.17(g) is included.

In addressing the listing of requirements (A)-(F) above, the Applicant states as follows:

- (A) This petition is being submitted along with a Request for Continued Examination. Thus, the Office should have ample time to effect such return prior to issuance of any patent on the application in issue.
- (B) Given that the unintentionally submitted information is confidential and proprietary, the failure to obtain its return would cause irreparable harm to the party in interest on whose behalf the information was submitted (the Applicant). Moreover, an opposing party in litigation could take the position that the unintentional disclosure resulted in a waiver of the attorney-client privilege both with respect to the contents of that disclosure as well as to related but undisclosed communications containing legal strategy and advice. Thus, the inadvertent disclosure, publication, and consumption of the information could cause irreparable harm to the Applicant.
- (C) Other than through the inadvertent submissions to the Patent Office described herein, the information has not otherwise been made public.
- (D) The Petitioner commits to retain the information for the period of any patent with regard to which such information is submitted.

Appl. No. : **14/485,612**
Filed : **09/12/2014**

- (E) As indicated, the information consists of portions of a letter received by Applicant's attorneys from a Korean law firm assisting with prosecution of the Korean application. The letter is proprietary material and included confidential comments from the Korean law firm. The contents of the letter are not prior art to the present application, and are clearly not material under 37 CFR 1.56; and
- (F) Petitioner includes herewith the petition fee as set forth in 37 CFR 1.17(g).

Statement of the Action or Relief Requested

For the reasons set forth herein, Applicant requests that the USPTO expunge the Submitted Document (or at least pages 2-4 of the Submitted Document) from the prosecution file of the present application.

The Commissioner is hereby authorized to charge the fee set 37 C.F.R. § 1.17(g), and any other necessary fees, including any fees for additional extension of time, which may be required, now or in the future, or credit any overpayment to Deposit Account No. 11-1410. If there are any obstacles to a prompt approval of this petition, the Patent and Trademark Office is invited to call the undersigned attorney.

Respectfully submitted,

KNOBBE, MARTENS, OLSON & BEAR, LLP

Dated: 9/29/2015_____

By: /Sean Ambrosius/_____

Sean P. Ambrosius
Registration No. 65,290
Attorney of Record
Customer No. 20,995
(949) 760-0404

15759339

Electronic Patent Application Fee Transmittal

Application Number:	14485612
Filing Date:	12-Sep-2014
Title of Invention:	VIDEO CAMERA
First Named Inventor/Applicant Name:	James H. Jannard
Filer:	Sean Patrick Ambrosius
Attorney Docket Number:	REDCOM.007C4

Filed as Large Entity

Filing Fees for Utility under 35 USC 111(a)

Description	Fee Code	Quantity	Amount	Sub-Total in USD(\$)
Basic Filing:				
Pages:				
Claims:				
Miscellaneous-Filing:				
Petition:				
Petition fee- 37 CFR 1.17(g) (Group II)	1463	1	200	200

Patent-Appeals-and-Interference:

Post-Allowance-and-Post-Issuance:

Description	Fee Code	Quantity	Amount	Sub-Total in USD(\$)
Extension-of-Time:				
Miscellaneous:				
Request for Continued Examination	1801	1	1200	1200
Total in USD (\$)				1400

Electronic Acknowledgement Receipt

EFS ID:	23585353
Application Number:	14485612
International Application Number:	
Confirmation Number:	1068
Title of Invention:	VIDEO CAMERA
First Named Inventor/Applicant Name:	James H. Jannard
Customer Number:	20995
Filer:	Sean Patrick Ambrosius/Kevin Kraus
Filer Authorized By:	Sean Patrick Ambrosius
Attorney Docket Number:	REDCOM.007C4
Receipt Date:	29-SEP-2015
Filing Date:	12-SEP-2014
Time Stamp:	19:53:53
Application Type:	Utility under 35 USC 111(a)

Payment information:

Submitted with Payment	yes
Payment Type	Credit Card
Payment was successfully received in RAM	\$1400
RAM confirmation Number	6096
Deposit Account	111410
Authorized User	KNOBBE MARTENS OLSON AND BEAR

The Director of the USPTO is hereby authorized to charge indicated fees and credit any overpayment as follows:

Charge any Additional Fees required under 37 C.F.R. Section 1.16 (National application filing, search, and examination fees)

Charge any Additional Fees required under 37 C.F.R. Section 1.17 (Patent application and reexamination processing fees)

--	--	--	--	--	--

File Listing:

Document Number	Document Description	File Name	File Size(Bytes)/ Message Digest	Multi Part /.zip	Pages (if appl.)
1	Non Patent Literature	2015-07-30_OA_REDCOM-007V EPD1.PDF	177251	no	5
			e7763ade6debe11da03c7d9576ad385a19a d9d96		

Warnings:

Information:

2	Non Patent Literature	2015-08-27_IPRP_REDCOM-084 WO.pdf	364425	no	9
			295e4d161ce9d7dc5cbac701b79993c40d8 c653c		

Warnings:

Information:

3	Non Patent Literature	2015-08-12_ExaminationReport _REDCOM-007NZZ3.PDF	630083	no	2
			de7de5dcd82c5265e41d3cd365e23ec1a86 0367c		

Warnings:

Information:

4	Foreign Reference	CN_104702926_w-T.pdf	17850010	no	55
			1865e699ff9467964ebc777a8dbe073dc05 a08f5		

Warnings:

Information:

5	Non Patent Literature	2015-07-29_OA_REDCOM-007 QTW.pdf	2208750	no	9
			f3b6155bea60eb4fcd3654aaf3c5b47be3e7 62be		

Warnings:

Information:

6		IDS_REDCOM-007C4.pdf	57987	yes	3
			7d823b2f9f951c50ea32b94ecec6593323b3 d228c		

Multipart Description/PDF files in .zip description

Document Description	Start	End
Transmittal Letter	1	2
Information Disclosure Statement (IDS) Form (SB08)	3	3

Warnings:

Information:

7	Request for Continued Examination (RCE)	RCE_REDCOM-007C4.pdf	1349907	no	3
			94b39db5d4931619ee9a8aee8806435aeb a9f63a		
Warnings:					
Information:					
8	Petition for review by the Office of Petitions	EXPUNGE_REDCOM-007C4.pdf	30291	no	3
			2ae76d4f85d74b52c2b835661d03a7ca4eb 70747		
Warnings:					
Information:					
9	Fee Worksheet (SB06)	fee-info.pdf	32205	no	2
			6e7b468935a637ade0ba48745d6cd98862 98ef92		
Warnings:					
Information:					
Total Files Size (in bytes):				22700909	

This Acknowledgement Receipt evidences receipt on the noted date by the USPTO of the indicated documents, characterized by the applicant, and including page counts, where applicable. It serves as evidence of receipt similar to a Post Card, as described in MPEP 503.

New Applications Under 35 U.S.C. 111

If a new application is being filed and the application includes the necessary components for a filing date (see 37 CFR 1.53(b)-(d) and MPEP 506), a Filing Receipt (37 CFR 1.54) will be issued in due course and the date shown on this Acknowledgement Receipt will establish the filing date of the application.

National Stage of an International Application under 35 U.S.C. 371

If a timely submission to enter the national stage of an international application is compliant with the conditions of 35 U.S.C. 371 and other applicable requirements a Form PCT/DO/EO/903 indicating acceptance of the application as a national stage submission under 35 U.S.C. 371 will be issued in addition to the Filing Receipt, in due course.

New International Application Filed with the USPTO as a Receiving Office

If a new international application is being filed and the international application includes the necessary components for an international filing date (see PCT Article 11 and MPEP 1810), a Notification of the International Application Number and of the International Filing Date (Form PCT/RO/105) will be issued in due course, subject to prescriptions concerning national security, and the date shown on this Acknowledgement Receipt will establish the international filing date of the application.

From the INTERNATIONAL BUREAU

PCT

NOTIFICATION CONCERNING
TRANSMITTAL OF COPY OF INTERNATIONAL
PRELIMINARY REPORT ON PATENTABILITY
(CHAPTER I OF THE PATENT COOPERATION
TREATY)

(PCT Rule 44bis.1(c))

To:

DELANEY, Karoline, A.
Knobbe, Martens, Olson & Bear, LLP
2040 Main Street, 14th Floor
Irvine, CA 92614
ETATS-UNIS D'AMERIQUE

Date of mailing (<i>day/month/year</i>) 27 August 2015 (27.08.2015)		
Applicant's or agent's file reference REDCOM084WO		IMPORTANT NOTICE
International application No. PCT/US2014/016301	International filing date (<i>day/month/year</i>) 13 February 2014 (13.02.2014)	Priority date (<i>day/month/year</i>) 14 February 2013 (14.02.2013)
Applicant RED. COM, INC.		

The International Bureau transmits herewith a copy of the international preliminary report on patentability (Chapter I of the Patent Cooperation Treaty)

The International Bureau of WIPO 34, chemin des Colombettes 1211 Geneva 20, Switzerland Facsimile No. +41 22 338 82 70	Authorized officer <p style="text-align: center;">Kihwan Moon</p> e-mail: pt01.pct@wipo.int
---	--

PATENT COOPERATION TREATY

PCT

INTERNATIONAL PRELIMINARY REPORT ON PATENTABILITY

(Chapter I of the Patent Cooperation Treaty)

(PCT Rule 44bis)

Applicant's or agent's file reference REDCOM084WO	FOR FURTHER ACTION		See item 4 below
International application No. PCT/US2014/016301	International filing date (<i>day/month/year</i>) 13 February 2014 (13.02.2014)	Priority date (<i>day/month/year</i>) 14 February 2013 (14.02.2013)	
International Patent Classification (8th edition unless older edition indicated) See relevant information in Form PCT/ISA/237			
Applicant RED. COM, INC.			

- This international preliminary report on patentability (Chapter I) is issued by the International Bureau on behalf of the International Searching Authority under Rule 44 bis.1(a).
- This REPORT consists of a total of 8 sheets, including this cover sheet.

In the attached sheets, any reference to the written opinion of the International Searching Authority should be read as a reference to the international preliminary report on patentability (Chapter I) instead.
- This report contains indications relating to the following items:

<input checked="" type="checkbox"/>	Box No. I	Basis of the report
<input type="checkbox"/>	Box No. II	Priority
<input type="checkbox"/>	Box No. III	Non-establishment of opinion with regard to novelty, inventive step and industrial applicability
<input type="checkbox"/>	Box No. IV	Lack of unity of invention
<input checked="" type="checkbox"/>	Box No. V	Reasoned statement under Article 35(2) with regard to novelty, inventive step or industrial applicability; citations and explanations supporting such statement
<input type="checkbox"/>	Box No. VI	Certain documents cited
<input type="checkbox"/>	Box No. VII	Certain defects in the international application
<input checked="" type="checkbox"/>	Box No. VIII	Certain observations on the international application
- The International Bureau will communicate this report to designated Offices in accordance with Rules 44bis.3(c) and 93bis.1 but not, except where the applicant makes an express request under Article 23(2), before the expiration of 30 months from the priority date (Rule 44bis .2).

	Date of issuance of this report 18 August 2015 (18.08.2015)
The International Bureau of WIPO 34, chemin des Colombettes 1211 Geneva 20, Switzerland	Authorized officer Kihwan Moon
Facsimile No. +41 22 338 82 70	e-mail: pt01.pct@wipo.int

Form PCT/IB/373 (January 2004)

PATENT COOPERATION TREATY

From the
INTERNATIONAL SEARCHING AUTHORITY

PCT

**WRITTEN OPINION OF THE
INTERNATIONAL SEARCHING AUTHORITY**

(PCT Rule 43bis.1)

To:
DELANEY, KAROLINE, A.

KNOBBE, MARTENS, OLSON & BEAR, LLP 2040 MAIN
STREET, 14TH FLOOR IRVINE CA 92614 USA

Date of mailing
(day/month/year) **21 May 2014 (21.05.2014)**

Applicant's or agent's file reference
REDCOM084WO

FOR FURTHER ACTION
See paragraph 2 below

International application No.
PCT/US2014/016301

International filing date (day/month/year)
13 February 2014 (13.02.2014)

Priority date(day/month/year)
14 February 2013 (14.02.2013)

International Patent Classification (IPC) or both national classification and IPC
H04N 9/07(2006.01)i, H04N 9/64(2006.01)i

Applicant
RED. COM, INC.

1. This opinion contains indications relating to the following items:

- Box No. I Basis of the opinion
- Box No. II Priority
- Box No. III Non-establishment of opinion with regard to novelty, inventive step and industrial applicability
- Box No. IV Lack of unity of invention
- Box No. V Reasoned statement under Rule 43bis. I(a)(i) with regard to novelty, inventive step and industrial applicability; citations and explanations supporting such statement
- Box No. VI Certain documents cited
- Box No. VII Certain defects in the international application
- Box No. VIII Certain observations on the international application

2. **FURTHER ACTION**

If a demand for international preliminary examination is made, this opinion will be considered to be a written opinion of the International Preliminary Examining Authority ("IPEA") except that this does not apply where the applicant chooses an Authority other than this one to be the IPEA and the chosen IPEA has notified the International Bureau under Rule 66.1bis(b) that written opinions of this International Searching Authority will not be so considered.

If this opinion is, as provided above, considered to be a written opinion of the IPEA, the applicant is invited to submit to the IPEA a written reply together, where appropriate, with amendments, before the expiration of 3 months from the date of mailing of Form PCT/ISA/220 or before the expiration of 22 months from the priority date, whichever expires later.
For further options, see Form PCT/ISA/220.

Name and mailing address of the ISA/KR
International Application Division
Korean Intellectual Property Office
189 Cheongsa-ro, Seo-gu, Daejeon
Metropolitan City, 302-701, Republic of Korea
Facsimile No. +82-42-472-7140

Date of completion of this opinion

20 May 2014 (20.05.2014)

Authorized officer

KIM, Seong Woo

Telephone No. +82-42-481-3348



**WRITTEN OPINION OF THE
INTERNATIONAL SEARCHING AUTHORITY**

International application No.
PCT/US2014/016301

Box No. I Basis of this opinion

1. With regard to the **language**, this opinion has been established on the basis of :
 - the international application in the language in which it was filed
 - a translation of the international application into _____ which is the language of a translation furnished for the purposes of international search (Rules 12.3(a) and 23.1(b))
2. This opinion has been established taking into account the **rectification of an obvious mistake** authorized by or notified to this Authority under Rule 91 (Rule 43*bis*.1(a))
3. With regard to any **nucleotide and/or amino acid sequence** disclosed in the international application, this opinion has been established on the basis of a sequence listing filed or furnished:
 - a. (means)
 - on paper
 - in electronic form
 - b. (time)
 - in the international application as filed.
 - together with the international application in electronic form.
 - subsequently to this Authority for the purposes of search.
4. In addition, in the case that more than one version or copy of a sequence listing has been filed or furnished, the required statements that the information in the subsequent or additional copies is identical to that in the application as filed or does not go beyond the application as filed, as appropriate, were furnished.
5. Additional comments:

Box No. V Reasoned statement under Rule 43bis.1(a)(i) with regard to novelty, inventive step or industrial applicability; citations and explanations supporting such statement

1. Statement

Novelty (N)	Claims	1-21	YES
	Claims	NONE	NO
Inventive step (IS)	Claims	NONE	YES
	Claims	1-21	NO
Industrial applicability (IA)	Claims	1-21	YES
	Claims	NONE	NO

2. Citations and explanations :

Reference is made to the following documents:

D1 : US 2010-0265367 A1 (JAMES JANNARD et al.) 21 October 2010

D2 : US 2008-0259180 A1 (ILIA OVSIANNIKOV) 23 October 2008

1. Novelty and Inventive Step

1.1 Claims 1-15

1.1.1 Independent claim 1

D1, which is considered to be the closest prior art to the subject matter of **claim 1**, discloses a method comprising accessing video data acquired by an image sensor of a camera, the video data comprising a plurality of picture element values for each of a plurality of spatially interleaved color channels, the spatially interleaved color channels comprising a first green color channel, a second green color channel, a red color channel, and a blue color channel (see paragraphs [0048]-[0049], [0080], figures 3, 8 in D1), deleting some of green image data, wherein the green image data comprises the first and second green color channels (see paragraphs [0051]-[0056], figures 4-7 in D1), modifying a value of a pixel of the red color channel or the blue color channel using an average of surrounding green elements (see paragraphs [0063]-[0067] in D1), compressing the modified red color channel or the modified blue color channel, and remaining the green image data (see paragraphs [0067], [0070]-[0072] in D1), and storing compressed video data in a storage device (24) (see paragraph [0092], figures 1, 8 in D1). Claim 1 differs from D1 in a calculated value derived from values of a plurality of picture elements of a first green color channel. However, D2 discloses determining an average of pixel signals that are local and belong to the other green color channel as a pixel being corrected (see paragraphs [0029]-[0030], claims 1, 6, figures 9-10 in D2). Accordingly, claim 1 would have been obvious over a combination of D1 and D2. Therefore, claim 1 lacks an inventive step under PCT Article 33(3).

Continued on Supplemental Box

Box No. VIII Certain observations on the international application

The following observations on the clarity of the claims, description, and drawings or on the question whether the claims are fully supported by the description, are made:

The phrase "transforming the second green color channel least partly by" of claim 18 is considered to be a typo of "transforming the second green color channel at least partly by". Therefore, claim 18 does not meet the requirements of PCT Article 6.

Supplemental Box

In case the space in any of the preceding boxes is not sufficient.

Continuation of: Box No. V

1.1.2 Dependent claims 2-15

The additional feature of **claim 2** is identical to the feature of D1 in subtraction of green magnitudes (see paragraphs [0061]-[0065] in D1).

The additional features of **claims 3-9** are identical to the features of D2 in the average of pixel signals that are local and belong to the other green color channel as the pixel being corrected (see paragraphs [0029]-[0030], claims 1, 6, figures 9-10 in D2).

The additional features of **claims 10-11** are identical to the features of D1 in a Bayer pattern filter (see paragraph [0081] in D1).

The additional feature of **claim 12** is identical to the feature of D1 in a subtraction technique using the correlation of picture elements to achieve better compression (see paragraph [0062] in D1).

The additional feature of **claim 13** is identical to the feature of D1 in inserting flags indicating what portions of image data have been modified (by e.g., green image data subtraction) and which portions have not been so modified (see paragraph [0064] in D1).

The additional feature of **claim 14** is identical to the feature of D1 in modifying the value of the pixel of the red color channel or the blue color channel using the average of surrounding the green elements (see paragraphs [0063]-[0067] in D1).

The additional feature of **claim 15** is identical to the feature of D1 in the subtraction technique using the correlation of picture elements to achieve the better compression (see paragraph [0062] in D1).

Accordingly, **claims 2-15** would have been obvious over a combination of D1 and D2. Therefore, claims 2-15 lack an inventive step under PCT Article 33(3).

1.2 Claim 16

1.2.1 Independent claim 16

D1, which is considered to be the closest prior art to the subject matter of **claim 16**, discloses a video camera comprising a storage device (24) (see paragraph [0043], figure 1 in D1), an image sensor (18) configured to convert light into video data, the video data comprising a plurality of picture element values for each of a plurality of spatially interleaved color channels, the spatially interleaved color channels comprising a first green color channel, a second green color channel, a red color channel, and a blue color channel (see paragraphs [0043], [0048]-[0049], [0080], figures 1, 3, 8 in D1), and an image processing module (20) configured to delete some of green image data, wherein the green image data comprises the first and second green color channels (see paragraphs [0051]-[0056], figures 1, 4-7 in D1), modify a value of a pixel of the red color channel or the blue color channel using an average of surrounding green elements (see paragraphs [0063]-[0067] in D1), compress the modified red color

Continued on The Next Page

Supplemental Box

In case the space in any of the preceding boxes is not sufficient.
Continuation of : Previous Page

channel or the modified blue color channel, and remaining green image data (see paragraphs [0067], [0070]-[0072] in D1), and store compressed video data in the storage device (24) (see paragraph [0092], figures 1, 8 in D1). Claim 16 differs from D1 in a calculated value derived from values of a plurality of picture elements of a first green color channel. However, D2 discloses determining an average of pixel signals that are local and belong to the other green color channel as a pixel being corrected (see paragraphs [0029]-[0030], claims 1, 6, figures 9-10 in D2). Accordingly, claim 16 would have been obvious over a combination of D1 and D2. Therefore, claim 16 lacks an inventive step under PCT Article 33(3).

1.3 Claim 17

1.3.1 Independent claim 17

D1, which is considered to be the closest prior art to the subject matter of **claim 17**, discloses a video camera comprising a storage device (24) (see paragraph [0043], figure 1 in D1), a processor (see paragraphs [0067]-[0068] in D1) and an image processing module (20) configured to access video data acquired by an image sensor of a camera, the video data comprising a plurality of picture element values for each of a plurality of spatially interleaved color channels, the spatially interleaved color channels comprising a first green color channel, a second green color channel, a red color channel, and a blue color channel (see paragraphs [0043], [0048]-[0049], [0080], figures 1, 3, 8 in D1), delete some of green image data, wherein the green image data comprises the first and second green color channels (see paragraphs [0051]-[0056], figures 1, 4-7 in D1), modify a value of a pixel of the red color channel or the blue color channel using an average of surrounding green elements (see paragraphs [0063]-[0067] in D1), and compress the modified red color channel or the modified blue color channel, and remaining green image data (see paragraphs [0067], [0070]-[0072] in D1). Claim 17 differs from D1 in a calculated value derived from values of a plurality of picture elements of a first green color channel. However, D2 discloses determining an average of pixel signals that are local and belong to the other green color channel as a pixel being corrected (see paragraphs [0029]-[0030], claims 1, 6, figures 9-10 in D2). Accordingly, claim 17 would have been obvious over a combination of D1 and D2. Therefore, claim 17 lacks an inventive step under PCT Article 33(3).

1.4 Claims 18-21

1.4.1 Independent claim 18

D1, which is considered to be the closest prior art to the subject matter of **claim 18**, discloses a method comprising applying decompression algorithm to compressed video data for green picture elements (see

Continued on The Next Page

Supplemental Box

In case the space in any of the preceding boxes is not sufficient.

Continuation of : Previous Page

paragraph [0097], figure 12 in D1), wherein the compressed video data was compressed by deleting some of green image data, wherein the green image data comprises first and second green color channels (see paragraphs [0051]-[0056], figures 1, 4-7 in D1), modifying a value of a pixel of a red color channel or a blue color channel using an average of surrounding green elements (see paragraphs [0063]-[0067] in D1) and compressing the modified red color channel or the modified blue color channel, and remaining green image data (see paragraphs [0067], [0070]-[0072] in D1), and demosaicing the green picture elements (see paragraphs [0097]-[0099], figure 12 in D1). Claim 18 differs from D1 in a calculated value derived from values of a plurality of picture elements of a first green color channel. However, D2 discloses determining an average of pixel signals that are local and belong to the other green color channel as a pixel being corrected (see paragraphs [0029]-[0030], claims 1, 6, figures 9-10 in D2). Accordingly, claim 18 would have been obvious over a combination of D1 and D2. Therefore, claim 18 lacks an inventive step under PCT Article 33(3).

1.4.2 Dependent claims 19-21

Claims 19-21 further specify that a decoding comprises substantially reversing a transform operation and performing a decompression operation. However, the additional features of claims 19-21 are virtually suggested by the features of D1 considering demosaicing of the green picture elements, demosaicing of red and blue picture elements, and reconstructing of the red and blue picture elements (see paragraphs [0097]-[0099], figure 12 in D1). Accordingly, claims 19-21 would have been obvious over a combination of D1 and D2. Therefore, claims 19-21 lack an inventive step under PCT Article 33(3).

2. Industrial Applicability

Claims 1-21 are industrially applicable under PCT Article 33(4).

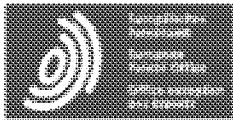

Bibliographic data: CN104702926 (A) — 2015-06-10

VIDEO CAMERA

Inventor(s):

Applicant(s):

Classification: - international: G06T3/40; H04N1/64; H04N19/186; H04N19/85; H04N9/04
- cooperative: G06T3/4015; G11B27/031; H04N1/648; H04N19/186;
H04N19/85; H04N19/91; H04N5/2252; H04N5/374;
H04N5/772; H04N9/045

Application number: CN2015141027 20080411

Priority number(s): US20070911196P 20070411 ; US20070017406P 20071228

Also published as: WO2008128112 (A1) US2015002695 (A1) US2015003801 (A1)
US2012301102 (A1) US2012301102 (A1) more

Abstract not available for CN104702926 (A)
Abstract of corresponding document: WO2008128112 (A1)

A video camera can be configured to highly compress video data in a visually lossless manner. The camera can be configured to transform blue and red image data in a manner that enhances the compressibility of the data. The data can then be compressed and stored in this form. This allows a user to reconstruct the red and blue data to obtain the original raw data for a modified version of the original raw data that is visually lossless when demosaiced. Additionally, the data can be processed in a manner in which the green image elements are demosaiced first and then the red and blue elements are reconstructed based on values of the demosaiced green image elements.

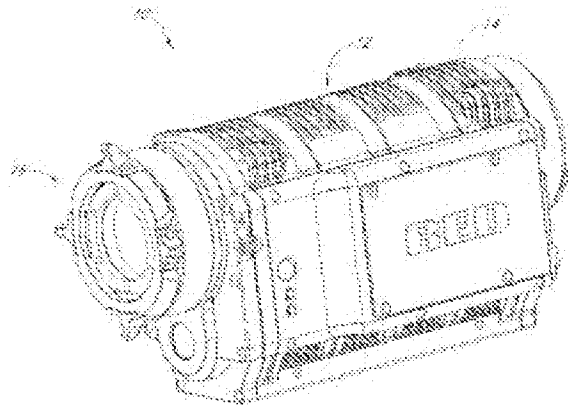

FIG. 2



Espacenet

Description: CN104702926 (A) — 2015-06-10

VIDEO CAMERA

Description not available for CN104702926 (A)

Description of corresponding document: WO2008128112 (A1)

A high quality text as facsimile in your desired language may be available amongst the following family members:

CA2683636 (A1) EP2145330 (B1) ES2486295 (T3) JP5231529 (B2) KR20100016214 (A)
MX2009010926 (A) RU2473968 (C2) SG178805 (A1) TW200913674 (A) US2008291319 (A1)
WO2008128112 (A1) CA2831698 (A1) EP2793219 (A1) KR20140109479 (A) US2012294582 (A1)
US2012301102 (A1) US2015002695 (A1) US2015003801 (A1)

The EPO does not accept any responsibility for the accuracy of data and information originating from other authorities than the EPO; in particular, the EPO does not guarantee that they are complete, up-to-date or fit for specific purposes.

VIDEO CAMERA

BACKGROUND

Field of the Inventions

The present inventions are directed to digital cameras, such as those for capturing still or moving pictures, and more particularly, to digital cameras that compress image data. Description of the Related Art

Despite the availability of digital video cameras, the producers of major motion pictures and some television broadcast media continue to rely film cameras. The film used for such provides video editors with very high resolution images that can be edited by conventional means. More recently, however, such film is often scanned, digitized and digitally edited.

SUMMARY OF THE INVENTIONS

Although some currently available digital video cameras include high resolution image sensors, and thus output high resolution video, the image processing and compression techniques used on board such cameras are too lossy and thus eliminate too much raw image data to be acceptable in the high end portions of the market noted above. An aspect of at least one of the embodiments disclosed herein includes the realization that video quality that is acceptable for the higher end portions of the markets noted above, such as the major motion picture market, can be satisfied by cameras that can capture and store raw or substantially raw video data having a resolution of at least about 2k and at a frame rate of at least about 23 frames per second.

Thus, in accordance with an embodiment, a video camera can comprise a portable housing, and a lens assembly supported by the housing and configured to focus light. A light sensitive device can be configured to convert the focused light into raw image data with a resolution of at least 2k at a frame rate of at least about twenty-three frames per second. The camera can also include a memory device and an image processing system configured to compress and store in the memory device the raw image data at a compression ratio of at least six to one and remain substantially visually lossless, and at a rate of at least about 23 frames per second.

In accordance with another embodiment, a method of recording a motion video with a camera can comprise guiding light onto a light sensitive device. The method can also include converting the light received by the light sensitive device into raw digital image data at a rate of at least greater than twenty three frames per second, compressing the raw digital image data, and recording the raw image data at a rate of at least about 23 frames per second onto a storage device.

In accordance with yet another embodiment, a video camera can comprise a lens assembly supported by the housing and configured to focus light and a light sensitive device configured to convert the focused light into a signal of raw image data representing the focused light. The camera can also include a memory device and means for compressing and recording the raw image data at a frame rate of at least about 23 frames per second.

In accordance with yet another embodiment, a video camera can comprise a portable housing having at least one handle configured to allow a user to manipulate the orientation with respect to at least one degree of movement of the housing during a video recording operation of the camera. A lens assembly can comprise at least one lens supported by the housing and configured to focus light at a plane disposed inside the housing. A light sensitive device can be configured to convert the focused light into raw image data with a horizontal resolution of at least 2k and at a frame rate of at least about twenty three frames per second. A memory device can also be configured to store video image data. An image processing system can be configured to compress and store in the memory device the raw image data at a compression ratio of at least six to one and remain substantially visually lossless, and at a rate of at least about 23 frames per second.

Another aspect of at least one of the inventions disclosed herein includes the realization that because the human eye is more sensitive to green wavelengths than any other color, green image data based modification of image data output from an image sensor can be used to enhance compressibility of the data, yet provide a higher quality video image. One such technique can include subtracting the magnitude of green light detected from the magnitudes of red and/or blue light detected prior to compressing the data. This can convert the red and/or blue image data into a more compressible form. For example, in the known processes for converting gamma corrected RGB data to YCbCr, the image is "decorrelated", leaving most of the image data in the Y (a.k.a. "luma"), and as such, the remaining chroma components are more compressible. However, the known techniques for converting to the YCbCr format cannot be applied directly to Bayer pattern data because the individual color data is not spatially correlated and Bayer pattern data includes twice as much green image data as blue or red image data. The processes of green image data subtraction, in accordance with some of the embodiments disclosed herein, can be similar to the YCbCr conversion noted above in that most of the image data is left in the green image data, leaving the remaining data in a more compressible form.

Further, the process of green image data subtraction can be reversed, preserving all the original raw data. Thus, the resulting system and method incorporating such a technique can provide lossless or visually lossless and enhanced compressibility of such video image data.

Thus, in accordance with an embodiment, a video camera can comprise a lens assembly supported by the housing and configured to focus light and a light sensitive device configured to convert the focused light into a raw signal of image data representing at least first, second, and third colors of the focused light. An image processing module can be configured to modify image

data of at least one of the first and second colors based on the image data of the third color. Additionally, the video camera can include a memory device and a compression device configured to compress the image data of the first, second, and third colors and to store the compressed image data on the memory device.

In accordance with another embodiment, a method of processing an image can be provided. The method can include converting an image and into first image data representing a first color, second image data representing a second color, and third image data representing a third color, modifying at least the first image data and the second image data based on the third image data, compressing the third image data and the modified first and second image data, and storing the compressed data.

In accordance with yet another embodiment, a video camera can comprise a lens assembly supported by the housing and configured to focus light. A light sensitive device can be configured to convert the focused light into a raw signal of image data representing at least first, second, and third colors of the focused light. The camera can also include means for modifying image data of at least one of the first and second colors based on the image data of the third color, a memory device, and a compression device configured to compress the image data of the first, second, and third colors and to store the compressed image data on the memory device.

BRIEF DESCRIPTION OF THE DRAWINGS

Figure 1 is a block diagram illustrating a system that can include hardware and/or can be configured to perform methods for processing video image data in accordance with an embodiment.

Figure 2 is an optional embodiment of a housing for the camera schematically illustrated in Figure 1.

Figure 3 is a schematic layout of an image sensor having a Bayer Pattern Filter that can be used with the system illustrated in Figure 1.

Figure 4 is a schematic block diagram of an image processing module that can be used in the system illustrated in Figure 1.

Figure 5 is a schematic layout of the green image data from the green sensor cells of the image sensor of Figure 3.

Figure 6 is a schematic layout of the remaining green image data of Figure 5 after an optional process of deleting some of the original green image data.

Figure 7 is a schematic layout of the red, blue, and green image data of Figure 5 organized for processing in the image processing module of Figure 1.

Figure 8 is a flowchart illustrating an image data transformation technique that can be used with the system illustrated in Figure 1.

Figure 8A is a flowchart illustrating a modification of the image data transformation technique of Figure 8 that can also be used with the system illustrated in Figure 1.

Figure 9 is a schematic layout of blue image data resulting from an image transformation process of Figure 8.

] Figure 10 is a schematic layout of red image data resulting from an image transformation process of Figure 8.

Figure 11 illustrates an exemplary optional transform that can be applied to the image data for gamma correction.

Figure 12 is a flowchart of a control routine that can be used with the system of Figure 1 to decompress and demosaic image data.

Figure 12A is a flowchart illustrating a modification of the control routine of Figure 12 that can also be used with the system illustrated in Figure 1.

Figure 13 is a schematic layout of green image data having been decompressed and demosaiced according to the flowchart of Figure 12.

Figure 14 is a schematic layout of half of the original green image data from Figure 13, having been decompressed and demosaiced according to the flowchart of Figure 12.

Figure 15 is a schematic layout of blue image data having been decompressed according to the flowchart of Figure 12.

Figure 16 is a schematic layout of blue image data of Figure 15 having been demosaiced according to the flowchart of Figure 12.

DETAILED DESCRIPTION OF EMBODIMENTS

Figure 1 is a schematic diagram of a camera having image sensing, processing, and compression modules, described in the context of a video camera for moving pictures. The embodiments disclosed herein are described in the context of a video camera having a single sensor device with a Bayer pattern filter because these embodiments have particular utility in this context. However, the embodiments and inventions herein can also be applied to cameras having other types of image sensors (e.g., CMY Bayer as well as other non-Bayer patterns), other numbers of image sensors, operating on different image format types, and being configured for still and/or moving pictures. Thus, it is to be understood that the embodiments disclosed herein are exemplary but nonlimiting embodiments, and thus, the inventions disclosed herein are not limited to the disclosed exemplary embodiments.

With continued reference to Figure 1, a camera 10 can include a body or housing 12 configured to support a system 14 configured to detect, process, and optionally store and/or replay video image data. For example, the system 14 can include optics hardware 16, an image sensor 18, an image processing module 20, a compression module 22, and a storage device 24. Optionally, the camera 10 can also include a monitor module 26, a playback module 28, and a display 30.

Figure 2 illustrates a nonlimiting exemplary embodiment of the camera 10. As shown in Figure 2, the optics hardware 16 can be supported by the housing 12 in a manner that leaves it exposed at its outer surface. In some embodiments, the system 14 is supported within the housing 12. For example, the image sensor 18, image processing module 20, and the compression module 22 can be housed within the housing 12. The storage device 24 can be mounted in the housing 12. Additionally, in some embodiments, the storage device 24 can be mounted to an exterior of the housing 12 and connected to the remaining portions of the system 14 through any type of known connector or cable. Additionally, the storage device 24 can be connected to the housing 12 with a flexible cable, thus allowing the storage device 24 to be moved somewhat independently from the housing 12. For example, with such a flexible cable connection, the storage device 24 can be worn on a belt of a user, allowing the total weight of the housing 12 to be reduced. Further, in some embodiments, the housing can include one or more storage devices 24 inside and mounted to its exterior. Additionally, the housing 12 can also support the monitor module 26, and playback module 28. Additionally, in some embodiments, the display 30 can be configured to be mounted to an exterior of the housing 12.

The optics hardware 16 can be in the form of a lens system having at least one lens configured

to focus an incoming image onto the image sensor 18. The optics hardware 16, optionally, can be in the form of a multi-lens system providing variable zoom, aperture, and focus. Additionally, the optics hardware 16 can be in the form of a lens socket supported by the housing 12 and configured to receive a plurality of different types of lens systems for example, but without limitation, the optics hardware 16 include a socket configured to receive various sizes of lens systems including a 50-100 millimeter (F2.8) zoom lens, an 18-50 millimeter (F2.8) zoom lens, a 300 millimeter (F2.8) lens, 15 millimeter (F2.8) lens, 25 millimeter (F1.9) lens, 35 millimeter (F1.9) lens, 50 millimeter (F1.9) lens, 85 millimeter (F 1.9) lens, and/or any other lens. As noted above, the optics hardware 16 can be configured such that despite which lens is attached thereto, images can be focused upon a light-sensitive surface of the image sensor 18.

The image sensor 18 can be any type of video sensing device, including, for example, but without limitation, CCD, CMOS, vertically-stacked CMOS devices such as the Foveon(R) sensor, or a multi-sensor array using a prism to divide light between the sensors. In some embodiments, the image sensor 18 can include a CMOS device having about 12 million photocells. However, other size sensors can also be used. In some configurations, camera 10 can be configured to output video at "2k" (e.g., 2048 x 1152 pixels), "4k" (e.g., 4,096 x 2,540 pixels), "4.5k" horizontal resolution or greater resolutions. As used herein, in the terms expressed in the format of xk (such as 2k and 4k noted above), the "x" quantity refers to the approximate horizontal resolution. As such, "4k" resolution corresponds to about 4000 or more horizontal pixels and "2k" corresponds to about 2000 or more pixels. Using currently commercially available hardware, the sensor can be as small as about 0.5 inches (8 mm), but it can be about 1.0 inches, or larger. Additionally, the image sensor 18 can be configured to provide variable resolution by selectively outputting only a predetermined portion of the sensor 18. For example, the sensor 18 and/or the image processing module can be configured to allow a user to identify the resolution of the image data output.

The camera 10 can also be configured to downsample and subsequently process the output of the sensor 18 to yield video output at 2K, 1080p, 720p, or any other resolution. For example, the image data from the sensor 18 can be "windowed", thereby reducing the size of the output image and allowing for higher readout speeds. However, other size sensors can also be used. Additionally, the camera 10 can be configured to upsample the output of the sensor 18 to yield video output at higher resolutions.

With reference to Figure 1 and 3, in some embodiments, the sensor 18 can include a Bayer pattern filter. As such, the sensor 18, by way of its chipset (not shown) outputs data representing magnitudes of red, green, or blue light detected by individual photocells of the image sensor 18. Figure 3 schematically illustrates the Bayer pattern output of the sensor 18. In some embodiments, for example, as shown in Figure 3, the Bayer pattern filter has twice as many green elements as the number of red elements and the number of blue elements. The chipset of the image sensor 18 can be used to read the charge on each element of the image sensor and thus output a stream of values in the well-known RGB format output.

With continued reference to Figure 4, the image processing module 20 optionally can be configured to format the data stream from the image sensor 18 in any known manner. In some embodiments, the image processing module 20 can be configured to separate the green, red, and blue image data into three or four separate data compilations. For example, the image processing module 20 can be configured to separate the red data into one data element, the blue data into one blue data element, and the green data into one green data element. For example, with reference to Figure 4, the image processing module 20 can include a red data processing module 32, a blue data image processing module 34, and a first green image data processing module 36.

As noted above, however, the Bayer pattern data illustrated in Figure 3, has twice as many green pixels as the other two colors. Figure 5 illustrates a data component with the blue and red data removed, leaving only the original green image data.

In some embodiments, the camera 10 can be configured to delete or omit some of the green image data. For example, in some embodiments, the image processing module 20 can be configured to delete 1/2 of the green image data so that the total amount of green image data is the same as the amounts of blue and red image data. For example, Figure 6 illustrates the remaining data after the image processing module 20 deletes V_i of the green image data. In the illustrated embodiment of Figure 6, the rows $n-3$, $n-1$, $n+1$, and $n+3$ have been deleted. This is merely one example of the pattern of green image data that can be deleted. Other patterns and other amounts of green image data can also be deleted.

In some alternatives, the camera 10 can be configured to delete V_i of the green image data after the red and blue image data has been transformed based on the green image data. This optional technique is described below following the description of the subtraction of green image data values from the other color image data.

Optionally, the image processing module 20 can be configured to selectively delete green image data. For example, the image processing module 20 can include a deletion analysis module (not shown) configured to selectively determine which green image data to delete. For example, such a deletion module can be configured to determine if deleting a pattern of rows from the green image data would result in aliasing artifacts, such as Moire lines, or other visually perceptible artifacts. The deletion module can be further configured to choose a pattern of green image data to delete that would present less risk of creating such artifacts. For example, the deletion module can be configured to choose a green image data deletion pattern of alternating vertical columns if it determines that the image captured by the image sensor 18 includes an image feature characterized by a plurality of parallel horizontal lines. This deletion pattern can reduce or eliminate artifacts, such as Moire lines, that might have resulted from a deletion pattern of alternating lines of image data parallel to the horizontal lines detected in the image.

However, this merely one exemplary, non-limiting example of the types of image features and deletion patterns that can be used by the deletion module. The deletion module can also be configured to detect other image features and to use other image data deletion patterns, such as for example, but without limitation, deletion of alternating rows, alternating diagonal lines, or other patterns. Additionally, the deletion module can be configured to delete portions of the other image data, such as the red and blue image data, or other image data depending on the type of sensor used.

Additionally, the camera 10 can be configured to insert a data field into the image data indicating what image data has been deleted. For example, but without limitation, the camera 10 can be configured to insert a data field into the beginning of any video clip stored into the storage device 24, indicating what data has been deleted in each of the "frames" of the video clip. In some embodiments, the camera can be configured to insert a data field into each frame captured by the sensor 18, indicating what image data has been deleted. For example, in some embodiments, where the image processing module 20 is configured to delete $\langle 1 \rangle A$ of the green image data in one deletion pattern, the data field can be as small as a single bit data field, indicating whether or not image data has been deleted. Since the image processing module 20 is configured to delete data in only one pattern, a single bit is sufficient to indicate what data has been deleted.

In some embodiments, as noted above, the image processing module 20 can be configured to selectively delete image data in more than one pattern. Thus, the image data deletion field can be larger, including a sufficient number of values to provide an indication of which of the plurality of different image data deletion patterns was used. This data field can be used by downstream components and or processes to determine to which spacial positions the remaining image data corresponds.

In some embodiments, the image processing module can be configured to retain all of the raw green image data, e.g., the data shown in Figure 5. In such embodiments, the image processing module can include one or more green image data processing modules.

As noted above, in known Bayer pattern filters, there are twice as many green elements as the number of red elements and the number of blue elements. In other words, the red elements comprise 25% of the total Bayer pattern array, the blue elements corresponded 25% of the Bayer pattern array and the green elements comprise 50% of the elements of the Bayer pattern array. Thus, in some embodiments, where all of the green image data is retained, the image processing module 20 can include a second green data image processing module 38. As such, the first green data image processing module 36 can process half of the green elements and the second green image data processing module 38 can process the remaining green elements. However, the present inventions can be used in conjunction with other types of patterns, such as for example, but without limitation, CMY and RGBW.

Figure 7 includes schematic illustrations of the red, blue and two green data components processed by modules 32, 34, 36, and 38 (Figure 4). This can provide further advantages because the size and configuration of each of these modules can be about the same since they are handling about the same amount of data. Additionally, the image processing module 20 can be selectively switched between modes in which it processes all of the green image data (by using both modules 36 and 38) and modes where λ A of the green image data is deleted (in which it utilizes only one of modules 36 and 38). However, other configurations can also be used.

Additionally, in some embodiments, the image processing module 20 can include other modules and/or can be configured to perform other processes, such as, for example, but without limitation, gamma correction processes, noise filtering processes, etc.

Additionally, in some embodiments, the image processing module 20 can be configured to subtract a value of a green element from a value of a blue element and/or red element. As such, in some embodiments, when certain colors are detected by the image sensor 18, the corresponding red or blue element can be reduced to zero. For example, in many photographs, there can be large areas of black, white, or gray, or a color shifted from gray toward the red or blue colors. Thus, if the corresponding pixels of the image sensor 18 have sensed an area of gray, the magnitude of the green, red, and blue, would be about equal. Thus, if the green value is subtracted from the red and blue values, the red and blue values will drop to zero or near zero. Thus, in a subsequent compression process, there will be more zeros generated in pixels that sense a black, white, or gray area and thus the resulting data will be more compressible. Additionally, the subtraction of green from one or both of the other colors can make the resulting image data more compressible for other reasons.

Such a technique can help achieve a higher effective compression ratio and yet remain visually lossless due to its relationship to the entropy of the original image data. For example, the entropy of an image is related to the amount of randomness in the image. The subtraction of image data of one color, for example, from image data of the other colors can reduce the randomness, and thus reduce the entropy of the image data of those colors, thereby allowing the data to be compressed at higher compression ratios with less loss. Typically, an image is not a collection of random color values. Rather, there is often a certain degree of correlation between surrounding picture elements. Thus, such a subtraction technique can use the correlation of picture elements to achieve better compression. The amount of compression will depend, at least in part, on the entropy of the original information in the image.

In some embodiments, the magnitudes subtracted from a red or blue pixel can be the magnitude of the value output from a green pixel adjacent to the subject red or blue pixel. Further, in some embodiments, the green magnitude subtracted from the red or blue elements can be derived from an average of the surrounding green elements. Such techniques are described in greater detail below. However, other techniques can also be used.

Optionally, the image processing module 20 can also be configured to selectively subtract green image data from the other colors. For example, the image processing module 20 can be

configured to determine if subtracting green image data from a portion of the image data of either of the other colors would provide better compressibility or not. In this mode, the image processing module 20 can be configured to insert flags into the image data indicating what portions of the image data has been modified (by e.g., green image data subtraction) and which portions have not been so modified. With such flags, a downstream demosaicing/reconstruction component can selectively add green image values back into the image data of the other colors, based on the status of such data flags.

Optionally, image processing module 20 can also include a further data reduction module (not shown) configured to round values of the red and blue data. For example, if, after the subtraction of green magnitudes, the red or blue data is near zero (e.g., within one or two on an 8-bit scale ranging from 0-255 or higher magnitudes for a higher resolution system). For example, the sensor 18 can be a 12-bit sensor outputting red, blue, and green data on a scale of 0-4095. Any rounding or filtering of the data performed the rounding module can be adjusted to achieve the desired effect. For example, rounding can be performed to a lesser extent if it is desired to have lossless output and to a greater extent if some loss or lossy output is acceptable. Some rounding can be performed and still result in a visually lossless output. For example, on a 8-bit scale, red or blue data having absolute value of up to 2 or 3 can be rounded to 0 and still provide a visually lossless output. Additionally, on a 12-bit scale, red or blue data having an absolute value of up to 10 to 20 can be rounded to 0 and still provide visually lossless output.

Additionally, the magnitudes of values that can be rounded to zero, or rounded to other values, and still provide a visually lossless output depends on the configuration of the system, including the optics hardware 16, the image sensor 18, the resolution of the image sensor, the color resolution (bit) of the image sensor 18, the types of filtering, anti-aliasing techniques or other techniques performed by the image processing module 20, the compression techniques performed by the compression module 22, and/or other parameters or characteristics of the camera 10.

As noted above, in some embodiments, the camera 10 can be configured to delete V_i of the green image data after the red and blue image data has been transformed based on the green image data. For example, but without limitation, the processor module 20 can be configured to delete V_i of the green image data after the average of the magnitudes of the surrounding green data values have been subtracted from the red and blue data values. This reduction in the green data can reduce throughput requirements on the associated hardware. Additionally, the remaining green image data can be used to reconstruct the red and blue image data, described in greater detail below with reference to Figures 14 and 16.

As noted above, the camera 10 can also include a compression module 22. The compression module 22 can be in the form of a separate chip or it can be implemented with software and another processor. For example, the compression module 22 can be in the form of a commercially available compression chip that performs a compression technique in accordance with the JPEG 2000 standard, or other compression techniques.

The compression module can be configured to perform any type of compression process on the data from the image processing module 20. In some embodiments, the compression module 22 performs a compression technique that takes advantage of the techniques performed by the image processing module 20. For example, as noted above, the image processing module 20 can be configured to reduce the magnitude of the values of the red and blue data by subtracting the magnitudes of green image data, thereby resulting in a greater number of zero values, as well as other effects. Additionally, the image processing module 20 can perform a manipulation of raw data that uses the entropy of the image data. Thus, the compression technique performed by the compression module 22 can be of a type that benefits from the presence of larger strings of zeros to reduce the size of the compressed data output therefrom.

Further, the compression module 22 can be configured to compress the image data from the image processing module 20 to result in a visually lossless output. For example, firstly, the

compression module can be configured to apply any known compression technique, such as, but without limitation, JPEG 2000, MotionJPEG, any DCT based codec, any codec designed for compressing RGB image data, H.264, MPEG4, Huffman, or other techniques.

Depending on the type of compression technique used, the various parameters of the compression technique can be set to provide a visually lossless output. For example, many of the compression techniques noted above can be adjusted to different compression rates, wherein when decompressed, the resulting image is better quality for lower compression rates and lower quality for higher compression rates. Thus, the compression module can be configured to compress the image data in a way that provides a visually lossless output, or can be configured to allow a user to adjust various parameters to obtain a visually lossless output. For example, the compression module 22 can be configured to compress the image data at a compression ratio of about 6:1, 7:1, 8:1 or greater. In some embodiments, the compression module 22 can be configured to compress the image data to a ratio of 12:1 or higher.

Additionally, the compression module 22 can be configured to allow a user to adjust the compression ratio achieved by the compression module 22. For example, the camera 10 can include a user interface that allows a user to input commands that cause the compression module 22 to change the compression ratio. Thus, in some embodiments, the camera 10 can provide for variable compression.

As used herein, the term "visually lossless" is intended to include output that, when compared side by side with original (never compressed) image data on the same display device, one of ordinary skill in the art would not be able to determine which image is the original with a reasonable degree of accuracy, based only on a visual inspection of the images.

With continued reference to Figure 1, the camera 10 can also include a storage device 24. The storage device can be in the form of any type of digital storage, such as, for example, but without limitation, hard disks, flash memory, or any other type of memory device. In some embodiments, the size of the storage device 24 can be sufficiently large to store image data from the compression module 22 corresponding to at least about 30 minutes of video at 12 mega pixel resolution, 12-bit color resolution, and at 60 frames per second. However, the storage device 24 can have any size.

In some embodiments, the storage device 24 can be mounted on an exterior of the housing 12. Further, in some embodiments, the storage device 24 can be connected to the other components of the system 14 through standard communication ports, including, for example, but without limitation, IEEE 1394, USB 2.0, IDE, SATA, etc. Further, in some embodiments, the storage device 24 can comprise a plurality of hard drives operating under a RAID protocol. However, any type of storage device can be used. [0065] With continued reference to Figure 1, as noted above, in some embodiments, the system can include a monitor module 26 and a display device 30 configured to allow a user to view video images captured by the image sensor 18 during operation. In some embodiments, the image processing module 20 can include a subsampling system configured to output reduced resolution image data to the monitor module 26. For example, such a subsampling system can be configured to output video image data to support 2K, 1080p, 720p, or any other resolution. In some embodiments, filters used for demosaicing can be adapted to also perform downsampling filtering, such that downsampling and filtering can be performed at the same time. The monitor module 26 can be configured to perform any type of demosaicing process to the data from the image processing module 20. Thereafter, the monitor module 26 can output a demosaiced image data to the display 30.

The display 30 can be any type of monitoring device. For example, but without limitation, the display 30 can be a four-inch LCD panel supported by the housing 12. For example, in some embodiments, the display 30 can be connected to an infinitely adjustable mount configured to allow the display 30 to be adjusted to any position relative to the housing 12 so that a user can view the display 30 at any angle relative to the housing 12. In some embodiments, the display 30 can be connected to the monitor module through any type of video cables such as, for example,

an RGB or YCC format video cable.

Optionally, the playback module 28 can be configured to receive data from the storage device 24, decompressed and demosaic the image data and then output the image data to the display 30. In some embodiments, the monitor module 26 and the playback module 28 can be connected to the display through an intermediary display controller (not shown). As such, the display 30 can be connected with a single connector to the display controller. The display controller can be configured to transfer data from either the monitor module 26 or the playback module 28 to the display 30.

Figure 8 includes a flowchart 50 illustrating the processing of image data by the camera 10. In some embodiments, the flowchart 50 can represent a control routine stored in a memory device, such as the storage device 24, or another storage device (not shown) within the camera 10. Additionally, a central processing unit (CPU) (not shown) can be configured to execute the control routine. The below description of the methods corresponding to the flow chart 50 are described in the context of the processing of a single frame of video image data. Thus, the techniques can be applied to the processing of a single still image. These processes can also be applied to the processing of continuous video, e.g., frame rates of greater than 12, as well as frame rates of 20, 23.976, 24, 30, 60, and 120, or other frame rates between these frame rates or greater.

With continued reference to Figure 8, control routine can begin at operation block 52. In the operation block 52, the camera 10 can obtain sensor data. For example, with reference to Figure 1, the image sensor 18, which can include a Bayer Sensor and chipset, can output image data.

For example, but without limitation, with reference to Figure 3, the image sensor can comprise a CMOS device having a Bayer pattern filter on its light receiving surface. Thus, the focused image from the optics hardware 16 is focused on the Bayer pattern filter on the CMOS device of the image sensor 18. Figure 3 illustrates an example of the Bayer pattern created by the arrangement of Bayer pattern filter on the CMOS device.

In Figure 3, column m is the fourth column from the left edge of the Bayer pattern and row n is the fourth row from the top of the pattern. The remaining columns and rows are labeled relative to column m and row n . However, this layout is merely chosen arbitrarily for purposes of illustration, and does not limit any of the embodiments or inventions disclosed herein.

As noted above, known Bayer pattern filters often include twice as many green elements as blue and red elements. In the pattern of figure 5, blue elements only appear in rows $n-3$, $n-1$, $n+1$, and $n+3$. Red elements only appear in rows $n-2$, n , $n+2$, and $n+4$. However, green elements appear in all rows and columns, interspersed with the red and blue elements.

Thus, in the operation block 52, the red, blue, and green image data output from the image sensor 18 can be received by the image processing module 20 and organized into separate color data components, such as those illustrated in Figure 7. As shown in Figure 7, and as described above with reference to Figure 4, the image processing module 20 can separate the red, blue, and green image data into four separate components. Figure 7 illustrates two green components (Green 1 and Green 2), a blue component, and a red component. However, this is merely one exemplary way of processing image data from the image sensor 18. Additionally, as noted above, the image processing module 20, optionally, can arbitrarily or selectively delete λ of the green image data.

After the operation block 52, the flowchart 50 can move on to operation block 54. In the operation block 56, the image data can be further processed. For example, optionally, any one or all of the resulting data (e.g., green 1, green 2, the blue image data from Figure 9, and the red image data from Figure 10) can be further processed.

For example, the image data can be pre-emphasized or processed in other ways. In some

embodiments, the image data can be processed to be more (mathematically) non-linear. Some compression algorithms benefit from performing such a linearization on the picture elements prior to compression. However, other techniques can also be used. For example, the image data can be processed with a linear curve, which provides essentially no emphasis.

In some embodiments, the operation block 54 can process the image data using curve defined by the function $y=x^{<[\text{Lambda}]>0.5}$. In some embodiments, this curve can be used where the image data was, for example but without limitation, floating point data in the normalized 0-1 range. In other embodiments, for example, where the image data is 12-bit data, the image can be processed with the curve $y=(x/4095)^{<[\text{Lambda}]>0.5}$. Additionally, the image data can be processed with other curves, such as $y=(x+c)^{<A>g}$ where $0.01 < g < 1$ and c is an offset, which can be 0 in some embodiments. Additionally, log curves can also be used. For example, curves in the form $y=A \cdot \log(B \cdot x + C)$ where A , B , and C are constants chosen to provide the desired results. Additionally, the above curves and processes can be modified to provide more linear areas in the vicinity of black, similar to those techniques utilized in the well-known Rec709 gamma curve. In applying these processes to the image data, the same processes can be applied to all of the image data, or different processes can be applied to the different colors of image data. However, these are merely exemplary curves that can be used to process the image data, or curves or transforms can also be used. Additionally, these processing techniques can be applied using mathematical functions such as those noted above, or with Look Up Tables (LUTs). Additionally, different processes, techniques, or transforms can be used for different types of image data, different ISO settings used during recording of the image data, temperature (which can affect noise levels), etc.

After the operation block 54, the flowchart 50 can move to an operation block 56. In the operation block 56, the red and blue picture elements can be transformed. For example, as noted above, green image data can be subtracted from each of the blue and red image data components. In some embodiments, a red or blue image data value can be transformed by subtracting a green image data value of at least one of the green picture elements adjacent to the red or blue picture element. In some embodiments, an average value of the data values of a plurality of adjacent green picture elements can be subtracted from the red or blue image data value. For example, but without limitation, average values of 2, 3, 4, or more green image data values can be calculated and subtracted from red or blue picture elements in the vicinity of the green picture elements.

For example, but without limitation, with reference to Figure 3, the raw output for the red element $R_{m-2,n-2}$ is surrounded by four green picture elements $G_{m-2;n-3}$, $G_{m-1;n-2}$, $G_{m+1;n-2}$, and $G_{m-2;n-1}$. Thus, the red element $R_{m-2;n-2}$ can be transformed by subtracting the average of the values of the surrounding green element as follows:

$$(1) R_{m,n} \leq R_{m,n} - (G_{m,n-1} + G_{m+1,n} + G_{m,n+1} + G_{m-1,n})/4$$

Similarly, the blue elements can be transformed in a similar manner by subtracting the average of the surrounding green elements as follows:

$$(2) B_{m+i}[\tau]_{n+i} = B_{m\pm,n+1} - (G_{m+1,n} + G_{m+2,n+1} + G_{m+i,n+2} + G_{m,n+i})/4$$

Figure 9 illustrates a resulting blue data component where the original blue raw data $B_{m-1,n-1}$ is transformed, the new value labeled as $B'_{m-1,n-1}$ (only one value in the component is filled in and the same technique can be used for all the blue elements). Similarly, Figure 10 illustrates the red data component having been transformed in which the transformed red element $R_{m-2,n-2}$ is identified as $R'_{m-2,n-2}$. In this state, the image data can still be considered "raw" data. For example, the mathematical process performed on the data are entirely reversible such that all of the original values can be obtained by reversing those processes.

With continued reference to Figure 8, after the operation block 56, the flowchart 50 can move on to an operation block 58. In the operation block 58, the resulting data, which is raw or can be

substantially raw, can be further compressed to using any known compression algorithm. For example, the compression module 22 (Figure 1) can be configured to perform such a compression algorithm. After compression, the compressed raw data can be stored in the storage device 24 (Figure 1).

Figure 8A illustrates a modification of the flowchart 50, identified by the reference numeral 50'. Some of the steps described above with reference to the flowchart 50 can be similar or the same as some of the corresponding steps of the flowchart 50' and thus are identified with the same reference numerals.

As shown in Figure 8A, the flowchart 50', in some embodiments, can optionally omit operation block 54. In some embodiments, the flowchart 50' can also include an operation block 57 in which a look up table can be applied to the image data. For example, an optional look-up table, represented by the curve of Figure 11, can be used to enhance further compression. In some embodiments, the look-up table of Figure 11 is only used for the green picture elements. In other embodiments, the look-up table can also be used for red and blue picture elements. The same look-up table may be used for the three different colors, or each color may have its own look-up table. Additionally, processes other than that represented by the curve of Figure 11 can also be applied.

By processing the image data in the manner described above with reference to Figures 8 and 8A, it has been discovered that the image data from the image sensor 18 can be compressed by a compression ratio of 6 to 1 or greater and remain visually lossless. Additionally, although the image data has been transformed (e.g., by the subtraction of green image data) all of the raw image data is still available to an end user. For example, by reversing certain of the processes, all or substantially all of the original raw data can be extracted and thus further processed, filtered, and/or demosaiced using any process the user desires.

For example, with reference to Figure 12, the data stored in the storage device 24 can be decompressed and demosaiced. Optionally, the camera 10 can be configured to perform the method illustrated by flowchart 60. For example, but without limitation, the playback module 28 can be configured to perform the method illustrated by flowchart 60. However, a user can also transfer the data from the storage device 24 into a separate workstation and apply any or all of the steps and/or operations of the flowchart 60.

With continued reference to Figure 12, the flowchart 60 can begin with the operation block 62, in which the data from the storage device 24 is decompressed. For example, the decompression of the data in operation block 62 can be the reverse of the compression algorithm performed in operational block 58 (Figure 8). After the operation block 62, the flowchart 60 can move on to an operation block 64.

In the operation block 64, a process performed in operation block 56 (Figure 8) can be reversed. For example, the inverse of the curve of Figure 11 or the inverse of any of the other functions described above with reference to operation block 56 of Figures 8 and 8A, can be applied to the image data. After the operation block 64, the flowchart 60 can move on to a step 66.

In the operation block 66, the green picture elements can be demosaiced. For example, as noted above, all the values from the data components Green 1 and/or Green 2 (Figure 7) can be stored in the storage device 24. For example, with reference to Figure 5, the green image data from the data components Green 1, Green 2 can be arranged according to the original Bayer pattern applied by the image sensor 18. The green data can then be further demosaiced by any known technique, such as, for example, linear interpolation, bilinear, etc.

Figure 13 illustrates an exemplary layout of green image data demosaiced from all of the raw green image data. The green image elements identified with the letter Gx represent original raw (decompressed) image data and the elements identified with "DGx" represent elements that were derived from the original data through the demosaic process. This nomenclature is used

with regard to the below descriptions of the demosaicing process for the other colors. Figure 14 illustrates an exemplary image data layout for green image data demosaiced from <1>A of the original green image data.

With continued reference to Figure 12, the flowchart 60 can, after the operation block 66, move on to an operation block 68. In the operation block 68, the demosaiced green image data can be further processed. For example, but without limitation, noise reduction techniques can be applied to the green image data. However, any other image processing technique, such as anti-aliasing techniques, can also be applied to the green image data. After the operation block 68, the flowchart 60 can move on to an operation block 70.

In the operation block 70, the red and blue image data can be demosaiced. For example, firstly, the blue image data of Figure 9 can be rearranged according to the original Bayer pattern (Figure 15). The surrounding elements, as shown in Figure 16, can be demosaiced from the existing blue image data using any known demosaicing technique, including linear interpolation, bilinear, etc. As a result of demosaicing step, there will be blue image data for every pixel as shown in Figure 16. However, this blue image data was demosaiced based on the modified blue image data of Figure 9, i.e., blue image data values from which green image data values were subtracted.

The operation block 70 can also include a demosaicing process of the red image data. For example, the red image data from Figure 10 can be rearranged according to the original Bayer pattern and further demosaiced by any known demosaicing process such as linear interpolation, bilinear, etc.

After the operation block 70, the flowchart can move on to an operation block 72. In the operation block 72, the demosaiced red and blue image data can be reconstructed from the demosaiced green image data.

In some embodiments, each of the red and blue image data elements can be reconstructed by adding in the green value from co-sited green image element (the green image element in the same column "m" and row "n" position). For example, after demosaicing, the blue image data includes a blue element value $DB_{m-2;n-2}$. Because the original Bayer pattern of Figure 3 did not include a blue element at this position, this blue value $DB_{m-2;n-2}$ was derived through the demosaicing process noted above, based on, for example, blue values from any one of the elements $B_{m-3;n-3}$, $B_{m-1;n-3}$, $B_{m-3;n-1}$, and $B_{m-1;n-1}$ or by any other technique or other blue image elements. As noted above, these values were modified in operation block 54 (Figure 8) and thus do not correspond to the original blue image data detected by the image sensor 18. Rather, an average green value had been subtracted from each of these values. Thus, the resulting blue image data $DB_{m-2;n-2}$ also represents blue data from which green image data has been subtracted. Thus, in one embodiment, the demosaiced green image data for element $DG_{m-2;n-2}$ can be added to the blue image value $DB_{m-2;n-2}$ thereby resulting in a reconstructed blue image data value.

In some embodiments, optionally, the blue and/or red image data can first be reconstructed before demosaicing. For example, the transformed blue image data $B'_{m-1;n-1}$ can be first reconstructed by adding the average value of the surrounding green elements. This would result in obtaining or recalculating the original blue image data $B_{m-1;n-1}$. This process can be performed on all of the blue image data. Subsequently, the blue image data can be further demosaiced by any known demosaicing technique. The red image data can also be processed in the same or similar manners.

Figure 12A illustrates a modification of the flowchart 60, identified by the reference numeral 60'. Some of the steps described above with reference to the flowchart 60 can be similar or the same as some of the corresponding steps of the flowchart 60' and thus are identified with the same reference numerals.

As shown in Figure 12A, the flow chart 60' can include the operation block 68' following operation block 62. In operation block 68', a noise reduction technique can be performed on the image data. For example, but without limitation, noise reduction techniques can be applied to the green image data. However, any other image processing technique, such as anti-aliasing techniques, can also be applied to the green image data. After operation block 68', the flow chart can move on to operation block 70'

In operation block 70', the image data can be demosaiced. In the description set forth above with reference to operation blocks 66 and 70, the green, red, and blue image data can be demosaiced in two steps. However, in the present flow chart 60', the demosaicing of all three colors of image data is represented in a single step, although the same demosaicing techniques described above can be used for this demosaicing process. After the operation block 70', the flow chart can move on to operation block 72, in which the red and blue image data can be reconstructed, and operation block 64 in which an inverse look-up table can be applied.

After the image data has been decompressed and processed according to either of the flow charts 70 or 70', or any other suitable process, the image data can be further processed as demosaiced image data. [0100] By demosaicing the green image data before reconstructing the red and blue image data, certain further advantages can be achieved. For example, as noted above, the human eye is more sensitive to green light. Demosaicing and processing the green image data optimize the green image values, to which the human eye is more sensitive. Thus, the subsequent reconstruction of the red and blue image data will be affected by the processing of the green image data.

Additionally, Bayer patterns have twice as many green elements as red and blue elements. Thus, in embodiments where all of the green data is retained, there is twice as much image data for the green elements as compared to either the red or blue image data elements. Thus, the demosaicing techniques, filters, and other image processing techniques result in a better demosaiced, sharpened, or otherwise filtered image. Using these demosaiced values to reconstruct and demosaic the red and blue image data transfers the benefits associated with the higher resolution of the original green data to the process, reconstruction, and demosaicing of the red and blue elements. As such, the resulting image is further enhanced.

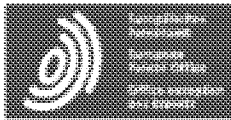

Claims: CN104702926 (A) — 2015-06-10

VIDEO CAMERA

Claims not available for CN104702926 (A)

Claims of corresponding document: WO2008128112 (A1)

A high quality text as facsimile in your desired language may be available amongst the following family members:

CA2683636 (A1) EP2145330 (B1) ES2486295 (T3) JP2010524408 (A) KR20140109479 (A)
MX2009010926 (A) RU2009136949 (A) TW200913674 (A) US2008291319 (A1) WO2008128112 (A1)
CA2631698 (A1) EP2793219 (A1) KR101478380 (B1) US2012294582 (A1) US2012301102 (A1)
US2015002695 (A1) US2015003801 (A1)

- [Original claims](#)
- [Claims tree](#)

The EPO does not accept any responsibility for the accuracy of data and information originating from other authorities than the EPO; in particular, the EPO does not guarantee that they are complete, up-to-date or fit for specific purposes.

WHAT IS CLAIMED IS:

1. A video camera comprising: a portable housing; a lens assembly supported by the housing and configured to focus light; a light sensitive device configured to convert the focused light into raw image data with a resolution of at least 2k at a frame rate of at least about twenty-three frames per second; a memory device; and an image processing system configured to compress and store in the memory device the raw image data at a compression ratio of at least six to one and remain substantially visually lossless, and at a rate of at least about 23 frames per second.
2. A video camera according to Claim 1, wherein the image processing system further comprises an image processing module configured to modify the image data representing at least one of the first and second colors based on the image data of the third color.
3. A video camera according to Claim 2, wherein the third color is green.
4. A video camera according to Claim 2, wherein the image processing module is configured to subtract a value of the image data of the third color from values of the image data of the first and second colors.
5. A video camera according to Claim 2, wherein the image processing system is configured to compress the image data of the first, second, and third colors after the image processing module has modified the image data representing at least one of the first and second colors.
6. A video camera according to Claim 2, wherein the image processing system is configured to delete about half of the image data representing the third color.

7. A video camera according to Claim 6, wherein the light sensitive device includes a first group of sensor cells configured to detect the first color, a second group of sensor cells configured to detect the second color, and a third group of sensor cells configured to detect the third color, the third group of sensor cells comprising twice as many sensor cells as the second group of sensor cells.

8. A video camera according to Claim 1, wherein the memory device is disposed within the housing.

9. A video camera according to Claim 1, wherein the memory device is supported on the outside of the housing.

10. A video camera according to Claim 1, wherein the memory device is connected to the housing with a flexible cable.

11. A video camera according to Claim 1, wherein the image processing system is configured to manipulate the raw image data so as to reduce an entropy of the raw image data before compression.

12. A video camera according to Claim 1, wherein the image processing system is configured to reduce an entropy of the raw image data before compression.

13. A video camera comprising: a lens assembly supported by the housing and configured to focus light; a light sensitive device configured to convert the focused light into a raw signal of image data representing at least first, second, and third colors of the focused light; an image processing module configured to modify image data of at least one of the first and second colors based on the image data of the third color; a memory device; and a compression device configured to compress the image data of the first, second, and third colors and to store the compressed image data on the memory device at a frame rate of at least about 23 frames per second.

14. A video camera according to Claim 13, wherein the third color is green.

15. A video camera according to Claim 13, wherein the image processing module is configured to subtract the values of the image data of the third color from the values of image data of at least one of the first and second colors.

16. A video camera according to Claim 15, wherein the values of the image data of the third color comprise an average of values of selected image data of the third color.

17. A video camera according to Claim 13, wherein the image processing module is configured to calculate an average of values of image data of the third color from at least two sensor cells adjacent to a sensor cell of the first color and to subtract the average value from a value of the image data from the sensor cell of the first color.

18. A video camera according to Claim 17, wherein the average of values comprises the average of values of image data of the third color from at least four sensor cells adjacent to the sensor cell of the first color.

19. A video camera according to Claim 13, wherein the light sensitive device comprises a Bayer sensor.

20. A method of recording a motion video with a camera, the method comprising: guiding light onto a light sensitive device; converting the light received by the light sensitive device into raw digital image data at a rate of at least greater than twenty three frames per second; compressing the raw digital image data; and recording the raw image data at a rate of at least about 23 frames per second onto a storage device.

21. The method according to Claim 20, wherein the step of compressing the raw digital image data comprises compressing the raw digital image data to an effective compression ratio of at least 6 to 1.
22. The method according to Claim 20, wherein the step of compressing the raw digital image data comprises compressing the raw digital image data with an effective compression ratio of at least about 12:1.
23. The method according to Claim 20, wherein the step of compressing the raw digital image data comprises compressing the raw digital image data such that the data remains visually lossless.
24. The method according to Claim 20, wherein the step of recording comprises storing the compressed raw digital image data.
25. The method according to Claim 20, wherein the step of recording comprises recording the raw image data at a rate of at least about 23.976 frames per second onto the storage device.
26. The method according to Claim 20 additionally comprising a step of manipulating the raw image data to reduce an entropy of the raw image data, before the step of recording.
27. The method according to Claim 20 additionally comprising a step of reducing an entropy of the raw image data, before the step of recording.
28. The method according to Claim 27 additionally comprising a step of compressing the raw image data in a visually lossless manner after the step of reducing an entropy.
29. A method of processing an image, comprising: converting an image and into raw first image data representing a first color, raw second image data representing a second color, and raw third image data representing a third color; modifying at least the raw first image data and the raw second image data based on the raw third image data; compressing the raw third image data and the modified raw first and raw second image data; and storing the compressed data at a frame rate of at least about 23 frames per second.
30. The method according to Claim 29, wherein the step of storing comprises storing the compressed data on a camera including an image sensing device used for the step of converting.
31. The method according to Claim 29 additionally comprising the step of deleting half of the third image data.
32. The method according to Claim 29, where the step of modifying comprises calculating an average of at least two pixels of third image data in subtracting the average from a pixel of the first image data that is adjacent to both of the at least two pixels of third image data.
33. The method according to Claim 32, where the step of calculating comprises calculating an average of at least four pixels of third image data.
34. The method according to Claim 29, wherein the third image data represents green image data.
35. The method according to Claim 29 additionally comprising decompressing the third image data and the modified first and second image data.
36. The method according to Claim 35 additionally comprising demosaicing the third image data.

37. The method according to Claim 36 additionally comprising demosaicing the first image data based on the demosaiced third image data.

38. The method according to Claim 36 additionally comprising demosaicing the first image data, then modifying the demosaiced first image data based on the demosaiced third image data.

39. The method according to Claim 29, wherein the step of modifying comprises calculating a value based on the third image data, subtracting the value from a value of the first image data, and wherein the method further comprises decompressing the third image data and the first and second modified image data, demosaicing the third image data, then demosaicing the first image data, then modifying the demosaiced first image data based on a value of the demosaiced third image data.

40. A video camera comprising: a lens assembly supported by the housing and configured to focus light; a light sensitive device configured to convert the focused light into a signal of raw image data representing the focused light; a memory device; and means for compressing and recording the raw image data at a frame rate of at least about 23 frames per second.

41. The video camera according to Claim 40, additionally comprising means for reducing an entropy of the raw image data before the means for compressing compresses the raw image data.

42. A video camera comprising: a portable housing having at least one handle configured to allow a user to manipulate the orientation with respect to at least one degree of movement of the housing during a video recording operation of the camera; a lens assembly comprising at least one lens supported by the housing and configured to focus light at a plane disposed inside the housing; a light sensitive device configured to convert the focused light into raw image data with a horizontal resolution of at least 2k and at a frame rate of at least about twenty three frames per second; a memory device configured to store video image data; an image processing system configured to compress and store in the memory device the raw image data at a compression ratio of at least six to one and remain substantially visually lossless, and at a rate of at least about 23 frames per second. 43. The video camera according to Claim 42, wherein the image processing system is configured to reduce an entropy of the raw image data before compressing the raw image data.

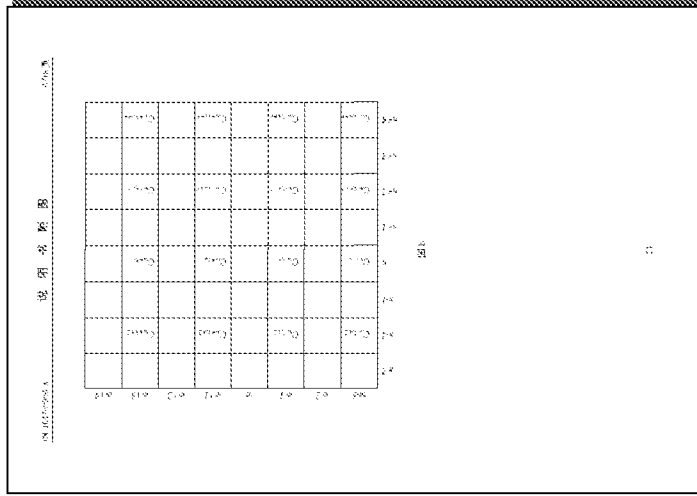
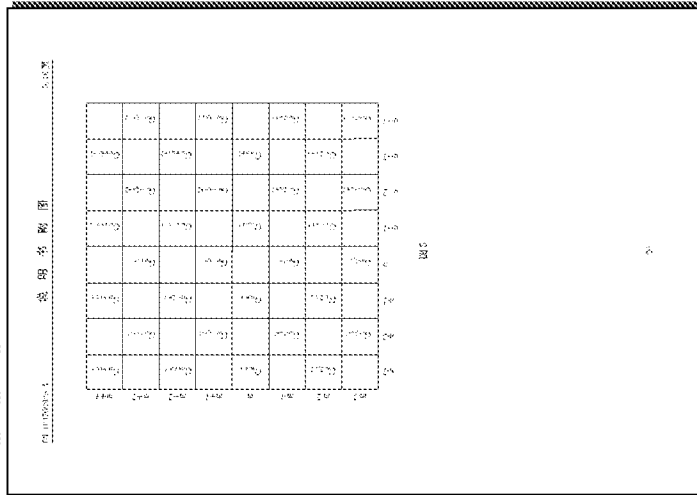
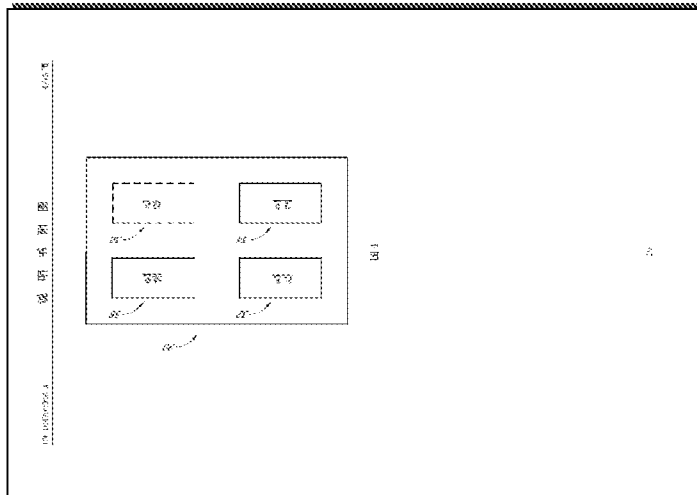
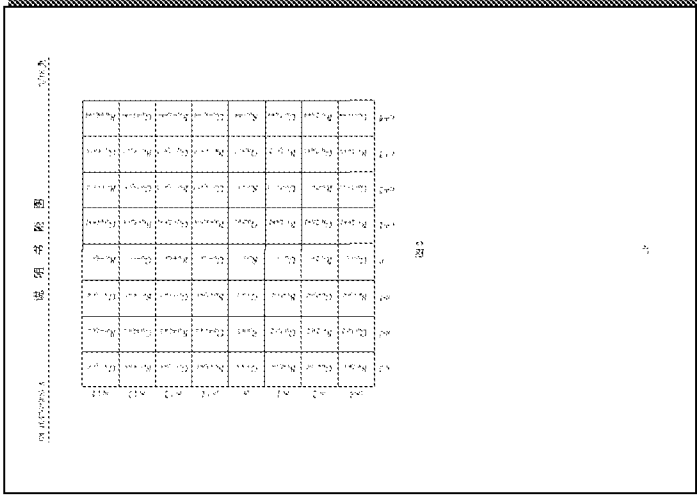
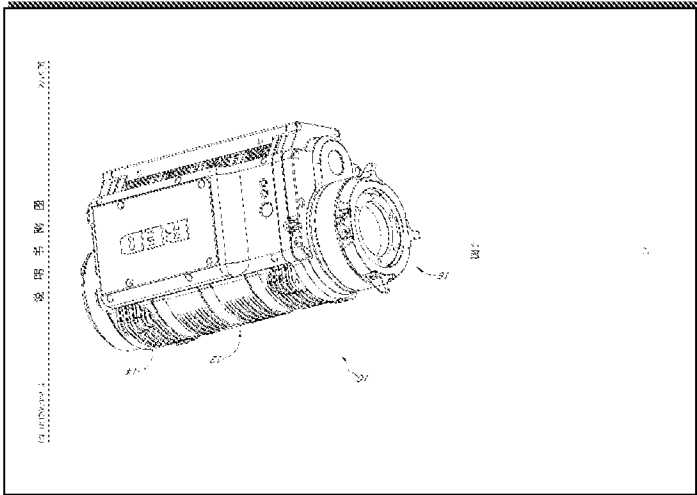
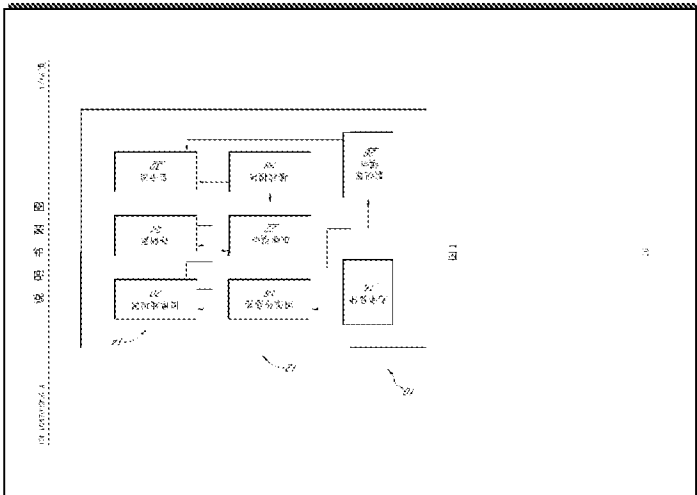

Drawing pages of CN104702926 A

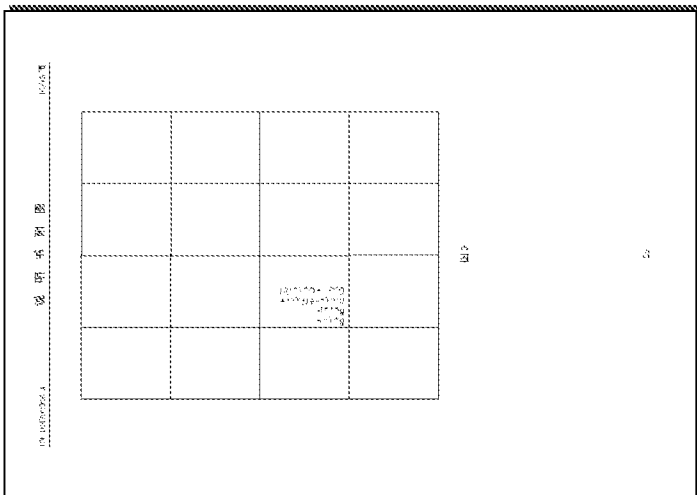
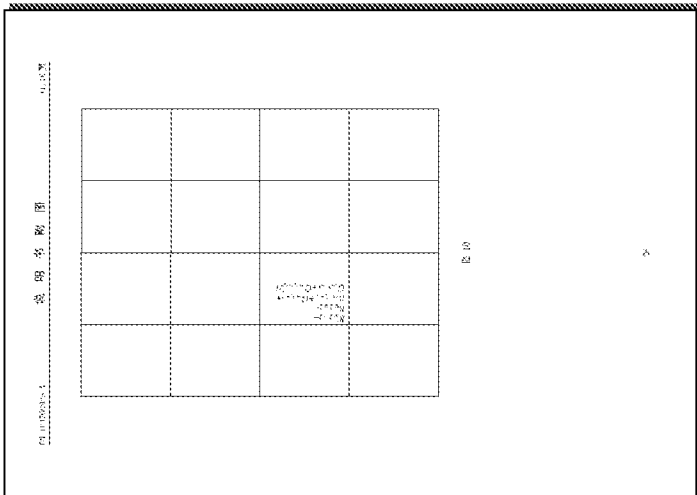
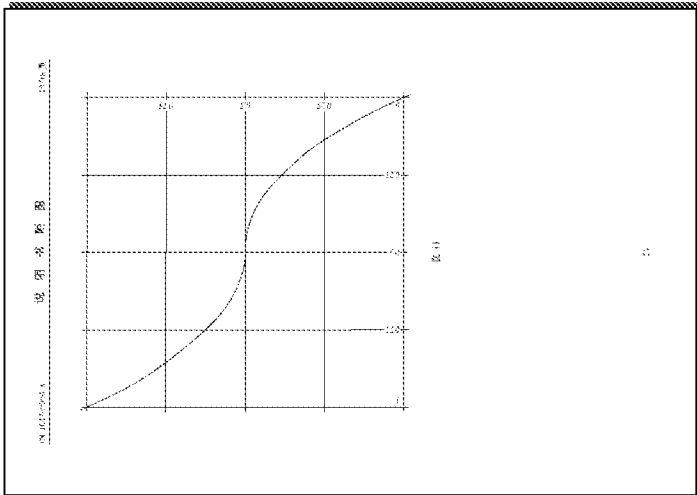
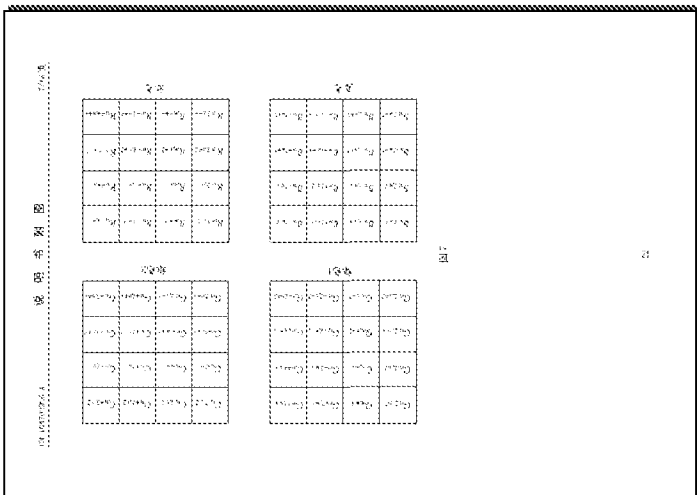
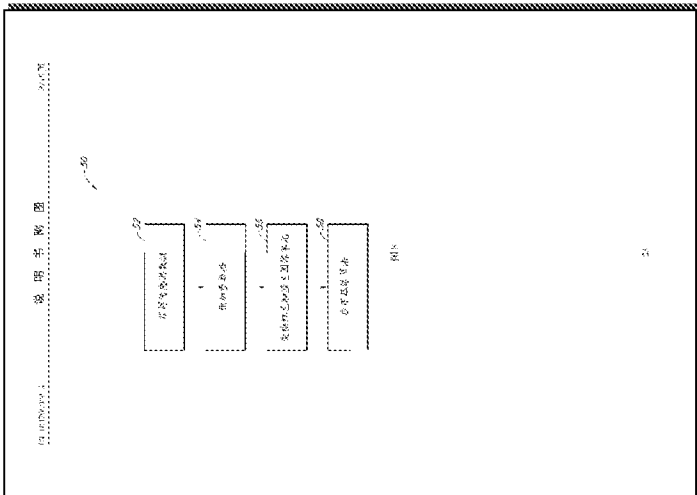
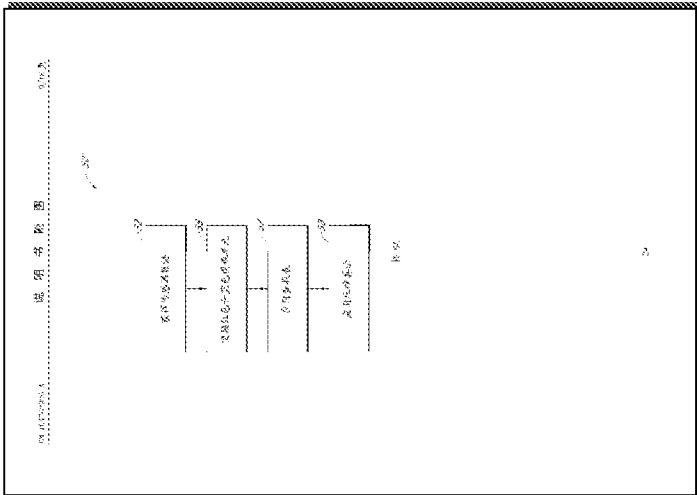

Drawing pages of CN104702926 A

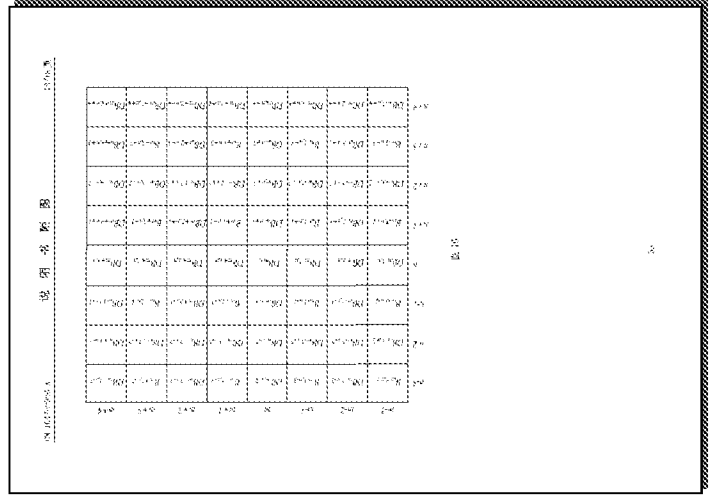
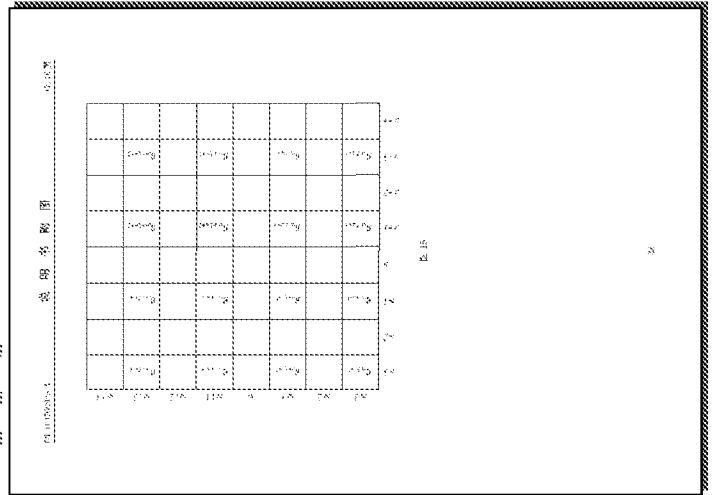
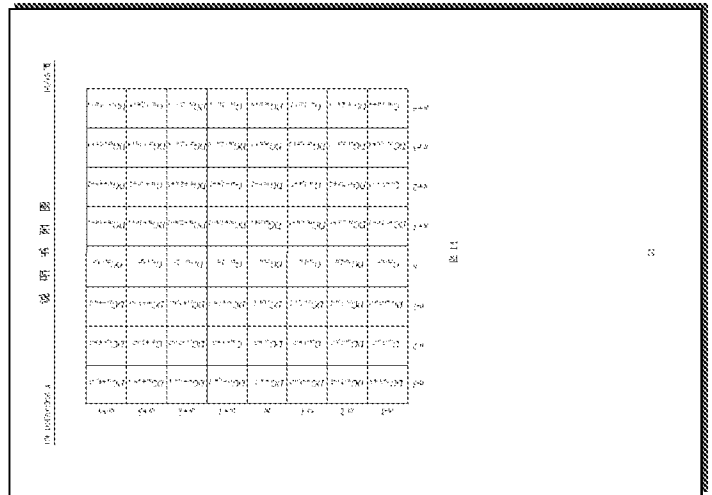
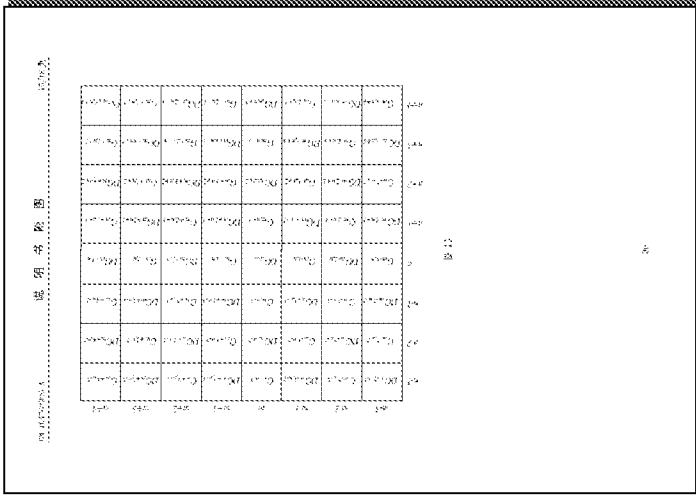
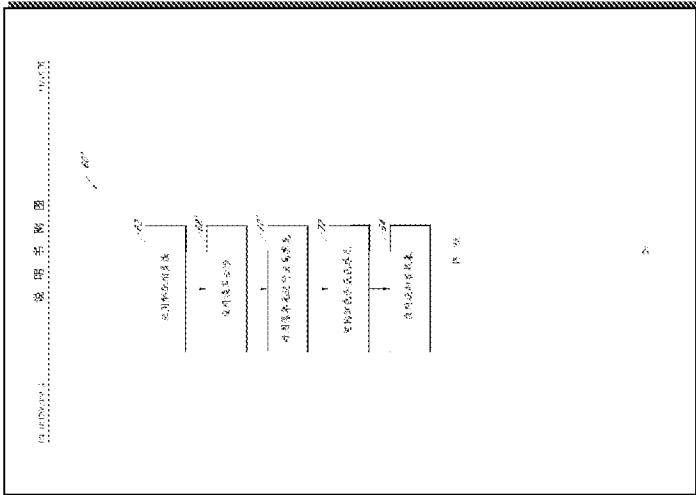
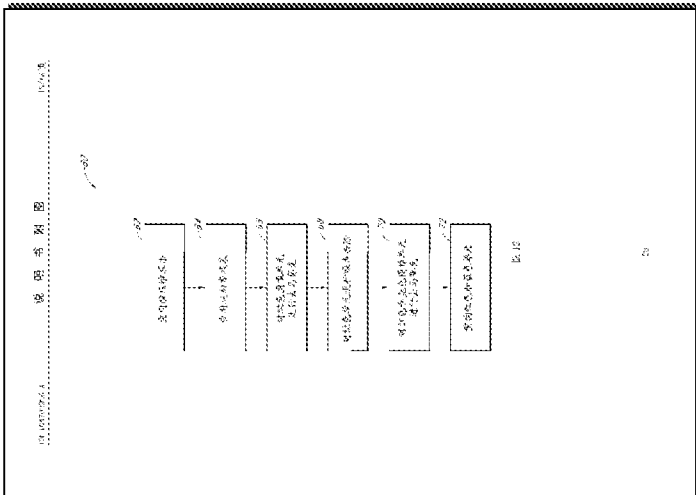

Drawing pages of CN104702926 A



(12) 发明专利申请

(10) 申请公布号 CN 104702926 A

(43) 申请公布日 2015.06.10

(21) 申请号 201510041027.X

H04N 19/186(2014.01)

(22) 申请日 2008.04.11

H04N 19/85(2014.01)

G06T 3/40(2006.01)

(30) 优先权数据

60/911,196 2007.04.11 US

61/017,406 2007.12.28 US

(62) 分案原申请数据

200880018570.6 2008.04.11

(71) 申请人 RED.COM 公司

地址 美国加利福尼亚州

(72) 发明人 詹姆斯·杰纳德

托马斯·格雷姆·纳特瑞斯

(74) 专利代理机构 北京英赛嘉华知识产权代理

有限责任公司 11204

代理人 余滕 王艳春

(51) Int. Cl.

H04N 9/04(2006.01)

H04N 1/64(2006.01)

权利要求书2页 说明书12页 附图18页

(54) 发明名称

摄像机

(57) 摘要

一种摄像机可配置为以视觉上无损的方式高度压缩视频数据。该摄像机可配置为以提高数据可压缩性的方式对蓝色和红色图像数据进行变换。然后,压缩数据并以这种形式存储。在去马赛克时,对于视觉上无损的原始数据的修改版本,这允许使用者重构红色和蓝色数据以获得原始数据。另外,可按这样的方式处理数据:其中,首先对绿色图像单元进行去马赛克,然后基于去马赛克的绿色图像单元的值来重构红色和蓝色单元。

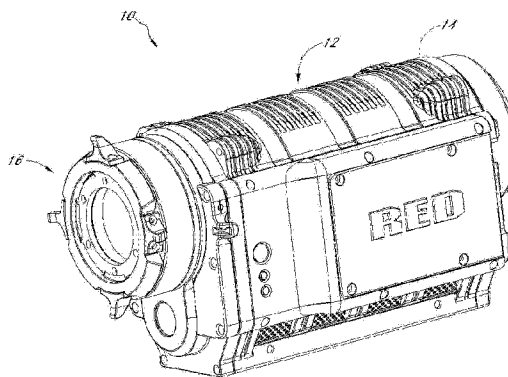

CN 104702926 A

1. 一种装置,包括:
 - 便携的壳体;
 - 透镜组件,通过所述壳体支撑并且配置为接收光;
 - 光敏器件,其配置为以至少约 23 帧每秒的帧频将所述光转换为至少 2k 分辨率的数字原始图像数据;
 - 存储器件,通过所述壳体支撑;以及
 - 图像处理系统,配置为对所述数字原始图像数据执行预加重处理,在执行所述预加重处理之后压缩所述数字原始图像数据使得所述数字原始图像数据在解压缩之后基本保持视觉上无损,并且以至少约 23 帧每秒的帧频将经压缩的数字原始图像数据存储于所述存储器件中,其中,所述预加重处理包括由函数 $y = (x+c)^g$ 定义的曲线,其中, $0.01 \leq g \leq 1$,并且 c 为偏移量。
2. 如权利要求 1 所述的装置,其中,所述预加重处理包括由函数 $y = (x)^{0.5}$ 定义的曲线。
3. 如权利要求 1 所述的装置,其中,所述图像处理系统配置为通过所述预加重处理对所述数字原始图像数据进行处理以在黑色附近提供增加的线性区域。
4. 如权利要求 1 所述的装置,其中,所述图像处理系统配置为使用查找表执行所述预加重。
5. 如权利要求 1 所述的装置,其中,所述数字原始图像数据代表第一颜色、第二颜色和第三颜色,并且所述图像处理系统配置为在压缩之前基于所述第三颜色的所选图像数据的平均值来修改代表所述第一颜色和所述第二颜色中的至少之一的图像数据。
6. 如权利要求 1 所述的装置,其中,所述数字原始图像数据代表第一颜色、第二颜色和第三颜色,并且所述图像处理系统配置为在压缩之前基于代表所述第三颜色的图像数据并使用周围单元之间的相关性来修改代表所述第一颜色和所述第二颜色中的至少之一的图像数据。
7. 如权利要求 6 所述的装置,其中,所述图像处理系统配置为通过围绕所述第一颜色的传感单元的至少两个传感单元计算所述第三颜色的图像数据的平均值,并且从来自所述第一颜色的传感单元的图像数据的值中减去所述平均值。
8. 如权利要求 6 所述的装置,其中,所述图像处理系统配置为在修改所述图像数据之前对所述图像数据进行预加重。
9. 如权利要求 6 所述的装置,其中,所述图像处理系统配置为在修改所述图像数据之后对所述图像数据进行预加重。
10. 如权利要求 1 所述的装置,其中,所述压缩以至少约 6:1 的压缩率进行。
11. 如权利要求 1 所述的装置,其中,所述图像处理系统包括压缩芯片,所述压缩芯片在所述便携的壳体内执行所述数字原始图像数据的压缩。
12. 一种装置,包括:
 - 便携的壳体;
 - 透镜组件,通过所述壳体支撑并且配置为接收光;
 - 光敏器件,配置为以至少约 23 帧每秒的帧频将所述光转换为至少 2k 分辨率的数字原始图像数据;

存储器件,通过所述壳体支撑;以及

图像处理系统,配置为对所述数字原始图像数据执行预加重处理,在执行所述预加重处理之后压缩所述数字原始图像数据使得所述数字原始图像数据在解压缩之后基本保持视觉上无损,并且以至少约 23 帧每秒的帧频将经压缩的数字原始图像数据存储在所述存储器件中,其中,所述预加重处理包括对数曲线,并且其中,所述对数曲线为 $y = A \cdot \log(B \cdot x + C)$ 的形式,其中, A、B 和 C 为常数。

13. 如权利要求 12 所述的装置,其中,所述图像处理系统配置为通过所述预加重处理对所述数字原始图像数据进行处理以在黑色附近提供增加的线性区域。

14. 如权利要求 12 所述的装置,其中,所述图像处理系统配置为使用查找表执行所述预加重。

15. 如权利要求 12 所述的装置,其中,所述数字原始图像数据代表第一颜色、第二颜色和第三颜色,并且所述图像处理系统配置为在压缩之前基于所述第三颜色的所选图像数据的平均值来修改代表所述第一颜色和所述第二颜色中的至少之一的图像数据。

16. 如权利要求 12 所述的装置,其中,所述数字原始图像数据代表第一颜色、第二颜色和第三颜色,并且所述图像处理系统配置为在压缩之前基于代表所述第三颜色的图像数据并使用周围单元之间的相关性来修改代表所述第一颜色和所述第二颜色中的至少之一的图像数据。

17. 如权利要求 16 所述的装置,其中,所述数字原始图像数据配置为通过围绕所述第一颜色的传感单元的至少两个传感单元计算所述第三颜色的图像数据的平均值,并且从来自所述第一颜色的传感单元的图像数据的值中减去所述平均值。

18. 如权利要求 16 所述的装置,其中,所述图像处理系统配置为在修改所述图像数据之前对所述图像数据进行预加重。

19. 如权利要求 16 所述的装置,其中,所述图像处理系统配置为在修改所述图像数据之后对所述图像数据进行预加重。

20. 如权利要求 12 所述的装置,其中,所述压缩以至少约 6:1 的压缩率进行。

21. 如权利要求 12 所述的装置,其中,所述图像处理系统包括压缩芯片,所述压缩芯片在所述便携的壳体内执行所述数字原始图像数据的压缩。

摄像机

[0001] 本申请为题为“摄像机”的中国专利申请的分案申请,该中国专利申请的申请号为 200880018570.6,申请日为 2008 年 4 月 11 日。

技术领域

[0002] 本发明涉及数码相机,例如,用于捕获静止或者活动图像的数码相机,更具体地,涉及压缩图像数据的数码相机。

背景技术

[0003] 尽管有数码相机可用,但是大多数活动图像和一些电视广播媒体的制作者仍旧依赖胶片摄像机。这里所用的胶片提供给视频编辑者可通过传统方法编辑的很高分辨率的图像。然而,最近,这种胶片常被扫描、数字化和数码编辑。

发明内容

[0004] 尽管一些目前可用的数码相机包括高分辨率图像传感器,从而输出高分辨率视频;但是,广泛应用在这些摄像机上的图像处理 and 压缩技术损耗太大,从而消除了太多原始图像数据而无法被上述高端市场接受。这里公开的至少一个实施方式的一个方面包括实现:可被上述高端市场(例如,大多数活动图像市场)接受的视频质量可由这样的相机满足,其可捕获和存储具有至少约 2k 分辨率和至少约 23 帧每秒帧频的原始的或者基本上原始的视频数据。

[0005] 这样,根据一个实施方式,一种摄像机可包含便携壳体、和通过该壳体支撑并配置为聚光的透镜组件。光敏器件可配置为以至少约 23 帧每秒的帧频将聚焦的光转换为具有至少 2k 分辨率的原始图像数据。该摄像机还可包括存储器件和图像处理系统,图像处理系统配置为以至少约 23 帧每秒的帧频和至少 6:1 的压缩率且基本上保持视觉上无损地压缩和存储原始图像数据到存储器件。

[0006] 根据另一个实施方式,用相机记录活动视频的方法可包含将光导向光敏器件。该方法还可包括将由光敏器件接收的光转换为具有至少大于 23 帧每秒帧频的原始数字图像数据、压缩该原始数字图像数据、和将该具有至少约 23 帧每秒帧频的原始图像数据记录到存储器件。

[0007] 根据又一个实施方式,一种摄像机可包含通过壳体支撑并配置为聚光的透镜组件和配置为将聚焦的光转换为代表该聚焦的光的原始图像数据的信号的光敏器件。该摄像机还可包括存储器件和用于压缩和记录该具有至少约 23 帧每秒帧频的原始图像数据的装置。

[0008] 根据再一个实施方式,一种摄像机可包含具有至少一个把手的便携壳体,其配置为允许使用者在该摄像机的视频记录操作期间,操作关于该壳体至少一个活动自由度的取向。透镜组件可包含通过该壳体支撑并配置为聚光至在该壳体内布置的平面上的至少一个透镜。光敏器件可配置为将聚焦的光转换为具有至少 2k 水平分辨率和至少约 23 帧每秒帧

频的原始图像数据。存储器件还可配置为存储视频图像数据。图像处理系统可配置为以至少约 23 帧每秒的帧频和至少 6:1 的压缩率压缩和存储原始图像数据至该存储器件,而且基本上保持视觉上无损。

[0009] 这里公开的至少一个实施方式的另一方面包括实现:因人眼对绿色波长比其他任何颜色都更敏感,因此对图像传感器输出的图像数据的基于绿色图像数据的修改可用于提高数据的可压缩性,还提供更高质量的视频图像。这种技术之一可包括在压缩数据之前从探测到的红色和 / 或蓝色光的量值中减去探测到的绿色光的量值。这可将红色和 / 或蓝色图像数据转换为更具压缩性的格式。例如,在将伽马校正过的 RGB 数据转换为 $Y' C_b C_r$ 的已知方法中,将图像“去相关”,余下大多数图像数据在 Y' (又名“亮度”),这样,剩余的色度分量更具压缩性。然而,用于转换为 $Y' C_b C_r$ 的已知技术无法直接应用于 Bayer 模式数据,因为各颜色数据空间不相关, Bayer 模式数据包括两倍于蓝色或者红色图像数据的绿色图像数据。根据这里公开的一些实施方式,减去绿色图像数据的方法,可类似于上述 $Y' C_b C_r$ 转换,因为大多数图像数据留在绿色图像数据,使剩余的数据成为更具压缩性的格式。

[0010] 进一步,可将减去绿色图像数据的过程逆反,以保留所有的原始数据。因此,结合了这一技术所产生的系统和方法可提供无损或者视觉上无损以及提高的视频图像数据的可压缩性。

[0011] 因此,根据一个实施方式,一种摄像机可包含通过壳体支撑并配置为聚光的透镜组件和配置为将聚焦的光转换为代表该聚焦的光的至少第一、第二和第三颜色的图像数据的原始信号的光敏器件。图像处理模块可配置为基于第三颜色的图像数据来修改第一和第二颜色中至少一个的图像数据。另外,该摄像机可包括存储器件和配置为压缩第一、第二和第三颜色的图像数据并将压缩的图像数据存储到存储器件的压缩器件。

[0012] 根据另一个实施方式,可提供一种处理图像的方法。该方法可包括:将图像转换为代表第一颜色的第一图像数据、代表第二颜色的第二图像数据和代表第三颜色的第三图像数据;基于第三图像数据来修改至少第一图像数据和第二图像数据;压缩第三图像数据和修改的第一和第二图像数据;以及存储压缩的数据。

[0013] 根据又一个实施方式,一种摄像机可包含通过壳体支撑并配置为聚光的透镜组件。光敏器件可配置为将聚焦的光转换为代表该聚焦的光的至少第一、第二和第三颜色的图像数据的原始信号。该摄像机还可包括:基于第三颜色的图像数据来修改第一和第二颜色中至少一个的图像数据的装置;存储器件;和配置为压缩第一、第二和第三颜色的图像数据并存储压缩的图像数据到存储器件的压缩器件。

附图说明

[0014] 图 1 是示出了根据一个实施方式的可包括硬件和 / 或可配置为执行用于处理视频图像数据的方法的一种系统的方框图;

[0015] 图 2 是图 1 中示意性示出的摄像机的壳体的一个可选实施方式;

[0016] 图 3 是可用于图 1 中所示系统的具有 Bayer 模式滤波器的图像传感器的示意性分布;

[0017] 图 4 是可用于图 1 中所示系统的图像处理模块的示意性方框图;

[0018] 图 5 是来自图 3 中图像传感器的绿色传感单元的绿色图像数据的示意性分布;

- [0019] 图 6 是经过删除一些原始绿色图像数据的可选过程以后图 5 中剩余绿色图像数据的示意性分布；
- [0020] 图 7 是组织为在图 1 的图像处理模块中处理的图 5 中红色、蓝色和绿色图像数据的示意性分布；
- [0021] 图 8 是示出了可用于图 1 中所示系统的图像数据转换技术的流程图；
- [0022] 图 8A 是示出了也可用于图 1 中所示系统的图像数据转换技术的修改的流程图；
- [0023] 图 9 是产生于图 8 中图像转换流程的蓝色图像数据的示意性分布；
- [0024] 图 10 是产生于图 8 中图像转换流程的红色图像数据的示意性分布；
- [0025] 图 11 示出了可应用于图像数据进行伽马校正的示例性可选变换；
- [0026] 图 12 是可用于图 1 中系统以对图像数据进行解压缩和去马赛克的控制程序的流程图；
- [0027] 图 12A 是示出了也可用于图 1 中所示系统的、图 12 中控制程序的修改的流程图；
- [0028] 图 13 是已根据图 12 中流程图解压缩和去马赛克的绿色图像数据的示意性分布；
- [0029] 图 14 是已根据图 12 中流程图解压缩和去马赛克的图 13 中原始绿色图像数据的一半的示意性分布；
- [0030] 图 15 是已根据图 12 中流程图解压缩的蓝色图像数据的示意性分布；以及
- [0031] 图 16 是已根据图 12 中流程图去马赛克的图 15 中蓝色图像数据的示意性分布。

具体实施方式

[0032] 图 1 是具有图像传感、处理和压缩模块的相机的示意图，描述为用于活动图像的摄像机的情形。这里公开的实施方式描述为这种情形：具有带 Bayer 模式滤波器的单个传感器件的摄像机，因为这些实施方式在这种情形下特别有益。然而，这里的实施方式和发明也可应用于具有其他类型的图像传感器（例如，CMY Bayer 以及其他非 Bayer 模式）的相机、具有其他数目的图像传感器的相机、以不同图像格式类型操作的相机、和配置为用于静止和 / 或活动图像的相机。因此，应该理解，这里公开的实施方式是示例性的、而不是限制性的实施方式，因此，这里公开的发明不限于所公开的示例性实施方式。

[0033] 继续参照图 1，相机 10 可包括机身或者壳体 12，其配置为支撑被配置为探测、处理、和可选择地存储和 / 或播放视频图像数据的系统 14。例如，系统 14 可包括光学硬件 16、图像传感器 18、图像处理模块 20、压缩模块 22、和存储器件 24。可选择地，相机 10 还可包括监视器模块 26、播放模块 28、和显示器 30。

[0034] 图 2 示出了相机 10 的一个非限制性的示例性实施方式。如图 2 中所示，光学硬件 16 可通过壳体 12 以使其外表面露出的方式来支撑。在一些实施方式中，系统 14 支撑在壳体 12 中。例如，图像传感器 18、图像处理模块 20、和压缩模块 22 可容置在壳体 12 中。存储器件 24 可安装在壳体 12 中。另外，在一些实施方式中，存储器件 24 可安装在壳体 12 的外部并通过任何类型的已知连接器或者电缆连接至系统 14 的剩余部分。另外，存储器件 24 可用柔性电缆连接至壳体 12，从而允许存储器件 24 在一定程度上独立于壳体 12 移动。例如，通过这种柔性电缆连接，存储器件 24 可戴在使用者的腰带上，允许壳体 12 的总重量减少。进一步，在一些实施方式中，壳体可包括位于其内部和安装到其外部的一个或者多个存储器件 24。另外，壳体 12 也可支撑监视器模块 26、和播放模块 28。另外，在一些实施方式

中,显示器 30 可配置为安装在壳体 12 的外部。

[0035] 光学硬件 16 可以是配置为将进入的图像聚焦至图像传感器 18 的、具有至少一个透镜的透镜系统的形式。光学硬件 16,可选择地,可以是提供有变焦、孔径和聚焦的多透镜系统的形式。另外,光学硬件 16 可以通过壳体 12 支撑并配置为容纳很多不同类型的透镜系统的透镜座的形式,例如,但不限于,光学硬件 16 包括配置为容纳各种尺寸的透镜系统的座,上述透镜系统包括 50-100 毫米 (F2.8) 变焦镜头、18-50 毫米 (F2.8) 变焦镜头、300 毫米 (F2.8) 透镜、15 毫米 (F2.8) 透镜、24 毫米 (F1.9) 透镜、35 毫米 (F1.9) 透镜、50 毫米 (F1.9) 透镜、85 毫米 (F1.9) 透镜、和 / 或任何其他透镜。如上所述,光学硬件 16 可配置使得不管附装哪种透镜,图像都可聚焦至图像传感器 18 的光敏面。

[0036] 图像传感器 18 可以是任何类型的视频传感器件,包括:例如,但不限于,CCD、CMOS、如 Foveon[®] 传感器的垂直堆叠的 CMOS 器件、或者用棱镜在传感器之间分光的多传感器阵列。在一些实施方式中,图像传感器 18 可包括具有约 1200 万感光单元的 CMOS 器件。然而,还可使用其他尺寸的传感器。在一些结构中,相机 10 可配置为以“2k”(例如,2048×1152 像素)、“4k”(例如,2096×2540 像素)、“4.5k”水平分辨率或者更大分辨率输出视频。这里所用,以 xk(例如,上述 2k 和 4k) 格式表达的术语中,数量 x 指大致的水平分辨率。照此,“4k”分辨率相当于大约 4000 或者更多水平像素,“2k”相当于大约 2000 或者更多像素。使用现有的商业可用硬件,传感器可以小至约 0.5 英寸 (8mm),但是,它也可以是约 1.0 英寸,或者更大。另外,图像传感器 18 可配置为通过选择性输出传感器 18 的仅预定部分来提供变化的分辨率。例如,传感器 18 和 / 或图像处理模块可配置为允许使用者识别图像数据输出的分辨率。

[0037] 相机 10 也可配置为下采样并接着处理传感器 18 的输出以产生 2K、1080p、720p、或者任何其他分辨率的视频输出。例如,来自传感器 18 的图像数据可被“窗采样”,从而减小输出图像的尺寸并允许更高的读出速度。但是,也可使用其他尺寸的传感器。另外,相机 10 可配置为对传感器 18 的输出上采样以产生更高分辨率的视频输出。

[0038] 参照图 1 至 3,在一些实施方式中,传感器 18 可包括 Bayer 模式滤波器。照此,传感器 18,通过它的芯片组(未示出)输出代表了图像传感器 18 的各感光单元探测到的红色、绿色或者蓝色光的幅值的数据。图 3 示意性示出了传感器 18 的 Bayer 模式输出。在一些实施方式中,例如,如图 3 所示,Bayer 模式滤波器具有两倍于红色单元数目和蓝色单元数目的绿色单元。图像传感器 18 的芯片组可用于读取图像传感器的各单元上的电荷,从而以已知的 RGB 格式输出数值流。

[0039] 接着参照图 4,图像处理模块 20 可选性地配置为以任何已知的方式形成来自图像传感器 18 的数据流的格式。在一些实施方式中,图像处理模块 20 可配置为将绿色、红色和蓝色图像数据分成三个或者四个单独的数据集。例如,图像处理模块 20 可配置为将红色数据分至一个数据单元,将蓝色数据分至一个蓝色数据单元,以及将绿色数据分至一个绿色数据单元。例如,参照图 4,图像处理模块 20 可包括红色数据处理模块 32、蓝色数据图像处理模块 34 和第一绿色图像数据处理模块 36。

[0040] 然而,如上所述,图 3 所示 Bayer 模式数据,具有两倍于另外两种颜色的绿色像素。图 5 示出了其中移除了蓝色和红色数据而仅余下原始绿色图像数据的数据单元。

[0041] 在一些实施方式中,相机 10 可配置为删除或者忽略一些绿色图像数据。例如,在

一些实施方式中,图像处理模块 20 可配置为删除 1/2 的绿色图像数据以便绿色图像数据的总数与蓝色和红色图像数据的数量一样。例如,图 6 示出了图像处理模块 20 删除 1/2 的绿色图像数据以后的剩余数据。在图 6 示出的实施方式中,已经删除了行 $n-3$ 、 $n-1$ 、 $n+1$ 和 $n+3$ 。这仅是可被删除的绿色图像数据的格式的一个示例。也可删除其他格式和其他数量的绿色图像数据。

[0042] 在一些替换方式中,相机 10 可配置为在基于绿色图像数据变换红色和蓝色图像数据以后删除 1/2 的绿色图像数据。这一可选的技术将在描述了从其他颜色图像数据减去绿色图像数据值之后进行描述。

[0043] 可选地,图像处理模块 20 可配置为选择性地删除绿色图像数据。例如,图像处理模块 20 可包括配置为选择性地确定哪些绿色图像数据被删除的删除分析模块(未示出)。例如,这样的删除模块可配置为确定从绿色图像数据中删除一定格式的行是否会导致混叠假象(例如,莫尔条纹)或者其他视觉上可察觉的假象。删除模块可进一步配置为选择一定格式的绿色图像数据进行删除,使得产生这种假象的风险较小。例如,删除模块可配置为,如果其确定图像传感器 18 捕获的图像包括表现为多个平行水平行的图像特征,则选择交替垂直列的绿色图像数据删除格式。该删除格式可减少或者消除删除平行于图像中探测到的水平行的图像数据的交替行的删除格式可产生的假象,例如,莫尔条纹。

[0044] 但是,这仅是可被删除模块使用的图像特征和删除格式的类型的一个示例性的、非限制性的例子。删除模块也可配置为探测其他图像特征和使用其他图像数据删除格式,例如,但不限于,交替行、交替对角线、或者其他格式的删除。另外,删除模块可配置为删除其他图像数据(例如,红色和蓝色图像数据)的部分,或者由使用的传感器的类型决定的其他图像数据。

[0045] 另外,相机 10 可配置为在图像数据中插入数据字段来指示删除了什么图像数据。例如,但不限于,相机 10 可配置为在存储器件 24 中所存储的任何视频剪辑的开头中插入数据字段,来指示在该视频剪辑的每一“帧”删除了什么数据。在一些实施方式中,相机可配置为在通过传感器 18 捕获的每一帧中插入数据字段,来指示删除了什么图像数据。例如,在图像处理模块 20 配置为按一个删除格式来删除 1/2 的绿色图像数据的一些实施方式中,数据字段可以小至一个位的数据字段,来指示是否删除了图像数据。因为图像处理模块 20 配置为仅按一个格式来删除数据,因此一个位足以指示删除了什么数据。

[0046] 在一些实施方式中,如上所述,图像处理模块 20 可配置为按多于一个的格式来选择性地删除图像数据。这样,图像数据删除字段可以大一些,包括足够数目的值以提供指示是使用了这些不同图像数据删除格式中的哪一个。该数据字段可通过下游组件和或处理来使用以确定剩余图像数据相应于哪些空间位置。

[0047] 在一些实施方式中,图像处理模块可配置为保留所有的原始绿色图像数据,例如,图 5 所示数据。在这些实施方式中,图像处理模块可包括一个或者多个绿色图像数据处理模块。

[0048] 如上所述,在已知的 Bayer 模式滤波器中,具有两倍于红色单元数目和蓝色单元数目的绿色单元。换句话说,红色单元包含总 Bayer 模式阵列的 25%,蓝色单元为 Bayer 模式阵列的 25%,绿色单元包含 Bayer 模式阵列单元的 50%。这样,在保留了所有的绿色图像数据的一些实施方式中,图像处理模块 20 可包括第二绿色数据图像处理模块 38。照此,

第一绿色数据图像处理模块 36 可处理一半的绿色单元,第二绿色图像数据处理模块 38 可处理剩余的绿色单元。但是,本发明可与其他类型的模式一起使用,例如,但不限于,CMY 和 RGBW。

[0049] 图 7 包括由模块 32、34、36 和 38(图 4)处理的红色、蓝色和两个绿色数据分量的示意性示出。这可提供进一步的优点,因为这些模块的每一个的尺寸和配置大致相同,因为他们处理大致相同数目的数据。另外,图像处理模块 20 可选择性地切换于其中处理所有的绿色图像数据(通过使用模块 36 和 38)的模式和其中删除了 1/2 的绿色图像数据的模式(其中仅利用模块 36 和 38 中的一个)之间。但是,也可使用其他配置。

[0050] 另外,在一些实施方式中,图像处理模块 20 可包括其他模块和/或可配置为执行其他处理,例如,但不限于,伽马校正处理、噪声过滤处理等等。

[0051] 另外,在一些实施方式中,图像处理模块 20 可配置为从蓝色单元和/或红色单元的值中减去绿色单元的值。照此,在一些实施方式中,当通过图像传感器 18 探测到某些颜色时,相应的红色或者蓝色单元可减少至零。例如,在很多摄影中,存在大面积的黑色、白色、或者灰色、或者从灰色过渡到红色或者蓝色的颜色。这样,如果图像传感器 18 的相应像素感测到一块灰色,绿色、红色和蓝色的幅值将大致相等。这样,如果从红色和蓝色值中减去绿色值,红色和蓝色值将降至零或者接近零。这样,在随后的压缩处理中,感测黑色、白色或者灰色块的像素中将产生更多的零,从而产生的数据将具有更大的可压缩性。另外,由于其他原因,从其他颜色中的一个或者两者中减去绿色可使产生的图像数据更具可压缩性。

[0052] 这种技术,由于其与原始图像数据的熵之间的关系,有助于实现更高效率的压缩率且仍保持视觉上无损。例如,图像的熵跟图像中随机的量有关。例如,从其他颜色的图像数据中减去一种颜色的图像数据可减少随机,从而减少这些颜色的图像数据的熵,因而允许数据以更高的压缩率和更少损失被压缩。典型地,图像不是随机颜色值的集合。所以,这种减去技术可使用单元的相关性来实现更好的压缩。压缩量将至少部分地取决于图像中原始信息的熵。

[0053] 在一些实施方式中,从红色或者蓝色像素中减去的量值可以是与与被减红色或者蓝色像素相邻的绿色像素输出的值的量值。进一步,在一些实施方式中,从红色或者蓝色单元中减去的绿色量值可以从周围绿色单元的平均值中得出。这种技术更详细地描述如下。但是,也可使用其他技术。

[0054] 可选地,图像处理模块 20 也可配置为从其他颜色中选择性地减去绿色图像数据。例如,图像处理模块 20 可配置为确定从其他颜色中任一个的图像数据的一部分中减去绿色图像数据是否会提供更好的压缩性。在这种模式中,图像处理模块 20 可配置为在图像数据中插入标记来指示修改了图像数据的什么部分(例如通过减去绿色图像数据修改)和没有修改哪部分。通过这些标记,下游去马赛克/重构组件可基于这些数据标记的状态将绿色图像值选择性地加回其他颜色的图像数据中。

[0055] 可选地,图像处理模块 20 还可包括配置为对红色和蓝色数据舍入(rounding)的另外的数据缩减模块(未示出)。例如,如果在减去绿色幅值以后红色或者蓝色数据接近零(例如,对范围为 0-255 的 8 位数值范围来说在 1 或者 2 以内,或者,对更高分辨率系统来说更高的幅值)。例如,传感器 18 可以为以数值范围 0-4095 来输出红色、蓝色和绿色数据的 12 位传感器。舍入模块对数据执行的任何舍入或者滤波可以调整以达成期望的效果。例

如,如果期望无损输出,则以较小程度执行舍入;而如果可接受一些损失或者损失性输出,则以较大的程度执行。可以执行一些舍入且仍产生视觉上无损的输出。例如,按 8- 位的数值范围,具有上至 2 或者 3 的绝对值的红色或者蓝色数据可舍入为 0 且仍提供视觉上无损的输出。另外,按 12- 位的数值范围,具有上至 10 至 20 的绝对值的红色或者蓝色数据可舍入为 0 且仍提供视觉上无损的输出。

[0056] 另外,可舍入为零或舍入为其他值、且仍提供视觉上无损的输出的值的量值取决于系统的配置,包括光学硬件 16、图像传感器 18、图像传感器的分辨率、图像传感器 18 的颜色分辨率(位)、滤波器的类型、图像处理模块 20 执行的抗混叠技术或者其他技术、压缩模块 22 执行的压缩技术、和 / 或相机 10 的其他参数或者特征。

[0057] 如上所述,在一些实施方式中,相机 10 可配置为在基于绿色图像数据变换红色和蓝色图像数据以后,删除 1/2 的绿色图像数据。例如,但不限于,处理模块 20 可配置为在从红色和蓝色数据值中减去周围绿色数据值的量值的平均值以后,删除 1/2 的绿色图像数据。绿色数据中的这种缩减可减少对相关硬件的吞吐量需求。另外,剩余的绿色图像数据可用于重构红色和蓝色图像数据,下面将参照图 14 和 16 更详细地说明。

[0058] 如上所述,相机 10 还可包括压缩模块 22。压缩模块 22 可以是单个芯片的形式或者可通过软件和另外的处理器实现。例如,压缩模块 22 可以是商业上可用的压缩芯片的形式,其根据 JPEG 2000 标准执行压缩技术,或者其他压缩技术。

[0059] 压缩模块可配置为对来自图像处理模块 20 的数据执行任何类型的压缩处理。在一些实施方式中,压缩模块 22 执行利用图像处理模块 20 执行的技术的压缩技术。例如,如上所述,图像处理模块 20 可配置为通过减去绿色图像数据的量值来减小红色和蓝色数据的值的量值,从而产生更多的零值,以及其他效果。另外,图像处理模块 20 可执行使用图像数据的熵的对原始数据的操作。这样,压缩模块 22 执行的压缩技术可为这样的类型:其受益于更大串的零的出现来减小所输出的压缩数据的大小。

[0060] 进一步,压缩模块 22 可配置为压缩来自图像处理模块 20 的图像数据以产生视觉上无损的输出。例如,首先,压缩模块可配置为应用任何已知的压缩技术,例如,但不限于, JPEG 2000、活动 JPEG (MotionJPEG)、任何基于 DCT 的编解码器、任何设计用于压缩 RGB 图像数据的编解码器、H. 264、MPEG4、霍夫曼或者其他技术。

[0061] 根据使用的压缩技术的类型,压缩技术的各种参数可设定为提供视觉上无损的输出。例如,上述很多压缩技术可调整为不同的压缩率,其中当解压时,产生的图像对低压缩率来说质量较好,而对高压缩率来说质量较低。这样,压缩模块可配置为以提供视觉上无损的输出的方式压缩图像数据,或者可配置为允许使用者调整各种参数以获得视觉上无损的输出。例如,压缩模块 22 可配置为以大约 6:1、7:1、8:1 或者更大的压缩率来压缩图像数据。在一些实施方式中,压缩模块 22 可配置为将图像数据压缩为 12:1 的比率或者更高。

[0062] 另外,压缩模块 22 可配置为允许使用者调整通过压缩模块 22 实现的压缩率。例如,相机 10 可包括用户界面,其允许使用者输入使压缩模块 22 改变压缩率的命令。这样,在一些实施方式中,相机 10 可提供可变的压缩。

[0063] 这里所用的术语“视觉上无损”意图包括这样的输出:当在同样的显示器件上与原始(从未压缩过)图像数据并排比较时,仅仅基于对图像的目测,本领域普通技术人员会无法确定哪幅图像是具有合理精确度的原始图像。

[0064] 继续参照图 1, 相机 10 还可包括存储器件 24。存储器件可以是任何类型的数字存储的形式, 例如, 但不限于, 硬盘、闪存或者任何其他类型的存储器件。在一些实施方式中, 存储器件 24 的尺寸足够大以存储来自压缩模块 22 的图像数据, 对应于 12 兆像素分辨率、12- 位颜色分辨率和 60 帧每秒的至少大约 30 分钟视频。但是, 存储器件 24 可以具有任何尺寸。

[0065] 在一些实施方式中, 存储器件 24 可安装在壳体 12 的外部。进一步, 在一些实施方式中, 存储器件 24 可通过标准通信端口连接至系统 14 的其他部件, 上述端口包括, 例如, 但不限于, IEEE 1394、USB 2. 0、IDE、SATA 等等。进一步, 在一些实施方式中, 存储器件 24 可包含根据 RAID 协议操作的多个硬驱动。但是, 可使用任何类型的存储器件。

[0066] 继续参照图 1, 如上所述, 在一些实施方式中, 系统可包括监视器模块 26 和显示器件 30, 配置为允许使用者在操作期间观看通过图像传感器 18 捕获的视频图像。在一些实施方式中, 图像处理模块 20 可包括配置为将缩减分辨率的图像数据输出至监视器模块 26 的二次抽样系统。例如, 这种二次抽样系统可配置为输出视频图像数据以支持 2K、1080p、720p 或者任何其他分辨率。在一些实施方式中, 用于去马赛克的滤波器还可适于执行下采样滤波, 以便下采样和滤波可以同时执行。监视器模块 26 可配置为对来自图像处理模块 20 的数据执行任何类型的去马赛克处理。其后, 监视器模块 26 可输出去马赛克的图像数据至显示器 30。

[0067] 显示器 30 可以是任何类型的监视器件。例如, 但不限于, 显示器 30 可以通过壳体 12 支撑的 4 英寸 LCD 面板。例如, 在一些实施方式中, 显示器 30 可以连接于无限量调整, 其配置为允许显示器 30 相对于壳体 12 调整为任何位置, 以便使用者可相对于壳体 12 以任何角度观看显示器 30。在一些实施方式中, 显示器 30 可通过任何类型的视频电缆, 例如, RGB 或者 YCC 格式视频电缆, 连接至监视器模块。

[0068] 可选地, 播放模块 28 可配置为接收来自存储器件 24 的数据, 对图像数据进行解压和去马赛克, 然后输出图像数据至显示器 30。在一些实施方式中, 监视器模块 26 和播放模块 28 可通过中间显示控制器 (未示出) 连接至显示器。照此, 显示器 30 可通过单个连接器连接至显示控制器。显示控制器可配置为从监视器模块 26 或者播放模块 28 传输数据至显示器 30。

[0069] 图 8 包括示出了相机 10 对图像数据的处理的流程图 50。在一些实施方式中, 流程图 50 可表示存储在存储器件 (例如, 存储器件 24 或者相机 10 中另外的存储器件 (未示出)) 中的控制流程。另外, 中央处理器 (CPU) (未示出) 可配置为执行该控制流程。下面对相应于在处理视频图像数据的单个帧的情况下描述的流程图 50 的方法进行介绍。这样, 这种技术可应用于对单个静止图像的处理。这些流程还可应用于对连续视频的处理, 例如, 大于 12 的帧频, 以及 20、23. 976、24、30、60 和 120 的帧频, 或者介于这些帧频之间或者更大的其他帧频。

[0070] 继续参照图 8, 控制流程可开始于操作块 52。在操作块 52 中, 相机 10 可获得传感器数据。例如, 参照图 1, 可包括 Bayer 传感器和芯片组的图像传感器 18 可输出图像数据。

[0071] 例如, 但不限于, 参照图 3, 图像传感器可包含在其光接收面具有 Bayer 模式滤波器的 CMOS 器件。这样, 来自光学硬件 16 的聚焦图像聚焦至图像传感器 18 的 CMOS 器件上的 Bayer 模式滤波器。图 3 示出了通过在 CMOS 器件上布置 Bayer 模式滤波器所产生的 Bayer

模式的一个例子。

[0072] 在图 3 中,列 m 是从 Bayer 模式的左边缘起第四列,而行 n 是从该格式的上边缘起第四行。其余的行和列相对于列 m 和行 n 来标记。但是,这种布局仅是为了示意性目的随机选出,并不限制这里公开的任何实施方式和发明。

[0073] 如上所述,已知的 Bayer 模式滤波器通常包括两倍于蓝色和红色单元的绿色单元。在图 5 的模式中,蓝色单元仅出现在行 $n-3$ 、 $n-1$ 、 $n+1$ 和 $n+3$ 中。红色单元仅出现在行 $n-2$ 、 n 、 $n+2$ 和 $n+4$ 中。但是,绿色单元出现在所有的行和列中,其间散布着红色和蓝色单元。

[0074] 因此,在操作块 52 中,从图像传感器 18 输出的红色、蓝色和绿色图像数据可由图像处理模块 20 接收,并组织为分离的颜色的数据分量中,例如,那些图 7 中示出的。如图 7 所示,如上参照图 4 所述,图像处理模块 20 可将红色、蓝色和绿色图像数据分成四个分离的分量。图 7 示出了两个绿色分量(绿色 1 和绿色 2)、一个蓝色分量和一个红色分量。但是,这仅是处理来自图像传感器 18 的图像数据的一个示例性方法。另外,如上所述,可选地,图像处理模块 20 可随机或者选择性地删除 1/2 的绿色图像数据。

[0075] 在操作块 52 之后,流程图 50 可前进至操作块 54。在操作块 56 中,可进一步处理图像数据。例如,可选地,可进一步处理所产生数据中的任一个或者全部(例如,绿色 1、绿色 2、来自图 9 的蓝色图像数据和来自图 10 的红色图像数据)。

[0076] 例如,可以其他方式预加重或者处理图像数据。在一些实施方式中,图像数据可被处理得更加(数学上)非线性。一些压缩算法受益于执行这种压缩前对单元的线性化。但是,还可使用其他技术。例如,图像数据可用线性曲线处理,其基本不提供加重。

[0077] 在一些实施方式中,操作块 54 可使用由函数 $y = x^{0.5}$ 定义的曲线来处理图像数据。在一些实施方式中,该曲线可在图像数据为,例如但不限于,标准化为 0-1 范围的浮点数据时使用。在其他实施方式中,例如,当图像数据为 12- 位数据时,可使用曲线 $y = (x/4095)^{0.5}$ 来处理图像。另外,可使用其他曲线来处理图像数据,例如 $y = (x+c)^g$, 其中 $0.01 < g < 1$ 且 c 为偏移量, c 在一些实施方式中可以为 0。另外,还可使用对数曲线。例如,形式为 $y = A \cdot \log(B \cdot x + C)$ 的曲线,其中, A 、 B 和 C 是为提供期望的结果所选择的常量。另外,可修改上述曲线和方法以在黑色附近提供更加线性的区域,类似于在众所周知的 Rec709 伽马校正中使用的那些技术。在将这些处理应用于图像数据时,可将同样的处理应用于所有的图像数据,或者,可将不同的处理应用于不同颜色的图像数据。但是,这些仅是可用于处理图像数据的示例性曲线,还可使用其它曲线或者变换。另外,可使用例如上述那些的数学函数、或者查找表(LUTs)来应用这些处理技术。另外,不同的处理、技术或者变换可用于不同类型的图像数据、记录图像数据中使用的不同 ISO 设定、温度(其可影响噪声水平)等等。

[0078] 在操作块 54 之后,流程图 50 可前进至操作块 56。在操作块 56 中,可变换红色和蓝色单元。例如,如上所述,可从蓝色和红色图像数据分量中的每一个中减去绿色图像数据。在一些实施方式中,红色或者蓝色图像数据值可通过减去邻近红色或者蓝色单元的至少一个绿色单元的绿色图像数据值来变换。在一些实施方式中,可从红色或者蓝色图像数据值中减去多个相邻绿色单元的数据值的平均值。例如,但不限于,可计算 2、3、4 或者更多个绿色图像数据值的平均值,并将其从绿色单元附近的红色或者蓝色单元中减去。

[0079] 例如,但不限于,参照图 3,红色单元 $R_{m-2,n-2}$ 的原始输出被四个绿色单元 $G_{m-2,n-3}$ 、

$G_{m-1,n-2}$ 、 $G_{m-3,n-2}$ 和 $G_{m-2,n-1}$ 围绕。这样,红色单元 $R_{m-2,n-2}$ 可如下通过减去周围绿色单元的值的平均值来变换:

$$[0080] \quad (1) R_{m,n} = R_{m,n} - (G_{m,n-1} + G_{m+1,n} + G_{m,n+1} + G_{m-1,n}) / 4$$

[0081] 类似地,蓝色单元可如下通过减去周围绿色单元的平均值的类似方式来变换:

$$[0082] \quad (2) B_{m+1,n+1} = B_{m+1,n+1} - (G_{m+1,n} + G_{m+2,n+1} + G_{m+1,n-2} + G_{m,n+1}) / 4$$

[0083] 图 9 示出了其中原始蓝色原始数据 $B_{m-1,n-1}$ 变换后所产生的蓝色数据分量,新值标记为 $B'_{m-1,n-1}$ (仅填充该分量中的一个值,且同样的技术可用于所有的蓝色单元)。类似地,图 10 示出了已经变换的红色数据分量,其中,变换了的红色单元 $R_{m-2,n-2}$ 标记为 $R'_{m-2,n-2}$ 。在这种状态下,图像数据仍被认为是“原始”数据。例如,对数据实施的数学处理完全可逆,以便可通过逆反那些流程来获得所有的原始值。

[0084] 继续参照图 8,操作块 56 之后,流程图 50 可前进至操作块 58。在操作块 58 中,产生的数据(其是原始的或者基本上原始)可使用任何已知的压缩算法来进一步压缩。例如,压缩模块 22(图 1)可配置为执行这样的压缩算法。压缩之后,压缩的原始数据可存储在存储器件 24(图 1)中。

[0085] 图 8A 示出了流程图 50 的一个修改,以参考数值 50' 来标记。上述参照流程图 50 的一些步骤,可与流程图 50' 的一些相应步骤类似或者相同,因而以相同的参考数值来标记。

[0086] 如图 8A 所示,在一些实施方式中,流程图 50' 可选地忽略操作块 54。在一些实施方式中,流程图 50' 还可包括操作块 57,其中可对图像数据应用查找表。例如,可选的查找表,如图 11 的曲线所表示的,可用于提高进一步的压缩。在一些实施方式中,图 11 的查找表仅仅用于绿色单元。在其他实施方式中,查找表还可用于红色和蓝色单元。相同的查找表可用于这三个不同的颜色,或者每个颜色可具有自己的查找表。另外,还可应用除了图 11 的曲线所体现的之外的。

[0087] 通过上述参照图 8 和 8A 所述的方式来处理图像数据,已发现,来自图像传感器 18 的图像数据可按 6:1 或者更大的压缩率来压缩且仍保持视觉上无损。另外,尽管对图像数据进行了变换(例如,绿色图像数据的减去),但所有的原始图像数据对于终端使用者仍然可得。例如,通过逆反某些过程,可提取所有的或者基本上所有的原始数据,并使用使用者期望的任何方法进一步处理、滤波和/或去马赛克。

[0088] 例如,参照图 12,可对存储在存储器件 24 中的数据进行解压和去马赛克。可选地,相机 10 可配置为执行流程图 60 示出的方法。例如,但不限于,播放模块 28 可配置为执行流程图 60 示出的方法。但是,使用者还可将数据从存储器件 24 传输至分离的工作站,并应用流程图 60 中的任何或者全部步骤和/或操作。

[0089] 继续参照图 12,流程图 60 可开始于操作块 62,其中对来自存储器件 24 的数据进行解压。例如,操作块 62 中对数据的解压可以是操作块 58(图 8)中执行的压缩算法的逆向。操作块 62 之后,流程图 60 可前进至操作块 64。

[0090] 在操作块 64 中,可逆反操作块 56(图 8)中执行的方法。例如,可将图 11 的曲线的逆向或者上述参照图 8 和 8A 中的操作块 56 所述的任何其他函数的逆应用于图像数据。操作块 64 之后,流程图 60 可前进至步骤 66。

[0091] 在操作块 66 中,可对绿色单元进行去马赛克。例如,如上所述,来自数据分量绿色

1 和 / 或绿色 2 (图 7) 的所有值可存储在存储器件 24 中。例如,参照图 5,来自数据分量绿色 1、绿色 2 的绿色图像数据可按照图像传感器 18 中应用的原始 Bayer 模式来布置。然后,绿色数据可通过任何已知的技术进一步去马赛克,例如,线性插值、双线性等等。

[0092] 图 13 示出了对所有的原始绿色图像数据去马赛克后的绿色图像数据的示例性布局。以字母 G_x 标记的绿色图像单元代表了原始(解压的)图像数据,而标记为 DG_x 的单元代表了通过去马赛克处理从原始数据得出的单元。该术语用于下述对其它颜色的去马赛克过程。图 14 示出了对 1/2 的原始绿色图像数据去马赛克后的绿色图像数据的示例性图像数据布局。

[0093] 继续参照图 12,流程图 60 可在操作块 66 之后前进至操作块 68。在操作块 68 中,可进一步处理去马赛克后的绿色图像数据。例如,但不限于,噪声去除技术可应用于绿色图像数据。但是,任何其他图像处理技术,例如,抗混叠技术,也可应用于绿色图像数据。操作块 68 之后,流程图 60 可前进至操作块 70。

[0094] 在操作块 70 中,可对红色和蓝色图像数据进行去马赛克。例如,首先,图 9 的蓝色图像数据可根据原始 Bayer 模式(图 15)重新布置。周围单元,如图 16 所示,可使用任何已知的去马赛克技术,包括线性插值、双线性等等,来从现有的蓝色图像数据进行去马赛克。作为去马赛克步骤的结果,对于每个像素将有蓝色图像数据,如图 16 所示。但是,基于图 9 的修改的蓝色图像数据,即,从其中减去了绿色图像数据值的蓝色图像数据值,对该蓝色图像数据进行去马赛克。

[0095] 操作块 70 还可包括对红色图像数据的去马赛克过程。例如,来自图 10 的红色图像数据可按照原始 Bayer 模式重新布置,并通过任何已知的去马赛克方法,例如线性插值、双线性等等,进一步去马赛克。

[0096] 操作块 70 之后,流程图可前进至操作块 72。在操作块 72 中,可根据去马赛克的绿色图像数据重构去马赛克的红色和蓝色图像数据。

[0097] 在一些实施方式中,红色和蓝色图像数据单元的每一个都可通过加上来自同位置处的绿色图像单元(与列“m”和行“n”相同位置的绿色图像单元)的绿色值来重构。例如,去马赛克以后,蓝色图像数据包括蓝色单元值 $DB_{m-2,n-2}$ 。因为图 3 的原始 Bayer 模式在该位置并不包括蓝色单元,因此该蓝色值 $DB_{m-2,n-2}$ 是基于例如来自单元 $B_{m-3,n-3}$ 、 $B_{m-1,n-3}$ 、 $B_{m-3,n-1}$ 和 $B_{m-1,n-1}$ 或者任何其他技术或者其他蓝色图像单元中的蓝色值、通过上述去马赛克过程导出的。如上所示,这些值在操作块(图 8)中被修改,因而并不相应于图像传感器 18 探测到的原始蓝色图像数据。更确切地,从这些值中的每一个中已减去平均绿色值。这样,产生的蓝色图像数据 $DB_{m-2,n-2}$ 还代表了已减去了绿色图像数据的蓝色数据。这样,在一个实施方式中,单元 $DG_{m-2,n-2}$ 的去马赛克的绿色图像数据可加到蓝色图像值 $DB_{m-2,n-2}$ 中,从而产生重构的蓝色图像数据值。

[0098] 在一些实施方式中,可选地,蓝色和 / 或红色图像数据可在去马赛克之前首先重构。例如,变换的蓝色图像数据 $B'_{m-1,n-1}$ 可首先通过加上周围绿色单元的平均值来重构。这将导致获得或者重新计算原始蓝色图像数据 $B_{m-1,n-1}$ 。该过程可对所有的蓝色图像数据执行。接着,蓝色图像数据可通过任何已知的去马赛克技术进一步去马赛克。红色图像数据也可按相同的或者类似的方式处理。

[0099] 图 12A 示出了流程图 60 的修改,以参考数值 60' 来标记。上述参照流程图 60 的

一些步骤,与流程图 60' 的一些相应步骤类似或者相同,因而以相同的参考数值来标记。

[0100] 如图 12A 所示,流程图 60' 可包括操作块 62 之后的操作块 68'。在操作块 68' 中,可对图像数据执行噪声去除技术。例如,但不限于,噪声去除技术可应用于绿色图像数据。但是,任何其他图像处理技术,例如抗混叠技术,也可应用于绿色图像数据。操作块 68' 之后,流程图可前进至操作块 70'。

[0101] 在操作块 70' 中,可对图像数据进行去马赛克。如上参照操作块 66 和 70 所述,绿色、红色和蓝色图像数据可按两步进行去马赛克。但是,在当前流程图 60' 中,所有三个颜色的图像数据的去马赛克体现在单个步骤中,尽管上述相同的去马赛克技术可应用于此去马赛克过程。操作块 70' 之后,流程图可前进至操作块 72 和操作快 64,操作块 72 中可重构红色和蓝色图像数据,操作块 64 中可应用逆向查找表。

[0102] 在根据流程图 70 或者 70' 中的任一个或者任何其他合适的方法对图像数据解压和处理以后,图像数据可进一步处理为去马赛克的图像数据。

[0103] 通过在重构红色和蓝色图像数据之前对绿色图像数据进行去马赛克,可实现某些进一步的优点。例如,如上所述,人眼对绿色光更加敏感。对绿色图像数据的去马赛克和处理优化了人眼更加敏感的绿色图像值。这样,随后对红色和蓝色图像数据的重构将受到对绿色图像数据的处理的影响。

[0104] 另外,Bayer 模式具有两倍于红色和蓝色单元的绿色通道。这样,在保留了所有绿色数据的实施方式中,与红色或者蓝色图像数据分量相比,绿色通道拥有两倍的图像数据。这样,去马赛克技术、滤波器和其他图像处理技术将产生更好的去马赛克、锐化或者另外的滤波的图像。使用这些去马赛克的值来对红色和蓝色图像数据进行重建和去马赛克将与更高分辨率的原始绿色通道相关的益处传至红色和蓝色单元的处理、重建和去马赛克。照此,产生的图像进一步得到增强。



图 1



图 2

	$m-3$	$m-2$	$m-1$	m	$m+1$	$m+2$	$m+3$	$m+4$
$n-3$	$B_{m-3,n-3}$	$C_{m-2,n-3}$	$B_{m-1,n-3}$	$C_{m,n-3}$	$B_{m+1,n-3}$	$C_{m+2,n-3}$	$B_{m+3,n-3}$	$C_{m+4,n-3}$
$n-2$	$C_{m-3,n-2}$	$R_{m-2,n-2}$	$C_{m-1,n-2}$	$R_{m,n-2}$	$C_{m+1,n-2}$	$R_{m+2,n-2}$	$C_{m+3,n-2}$	$R_{m+4,n-2}$
$n-1$	$B_{m-3,n-1}$	$C_{m-2,n-1}$	$B_{m-1,n-1}$	$C_{m,n-1}$	$B_{m+1,n-1}$	$C_{m+2,n-1}$	$B_{m+3,n-1}$	$C_{m+4,n-1}$
n	$C_{m-3,n}$	$R_{m-2,n}$	$C_{m-1,n}$	$R_{m,n}$	$C_{m+1,n}$	$R_{m+2,n}$	$C_{m+3,n}$	$R_{m+4,n}$
$n+1$	$B_{m-3,n+1}$	$C_{m-2,n+1}$	$B_{m-1,n+1}$	$C_{m,n+1}$	$B_{m+1,n+1}$	$C_{m+2,n+1}$	$B_{m+3,n+1}$	$C_{m+4,n+1}$
$n+2$	$C_{m-3,n+2}$	$R_{m-2,n+2}$	$C_{m-1,n+2}$	$R_{m,n+2}$	$C_{m+1,n+2}$	$R_{m+2,n+2}$	$C_{m+3,n+2}$	$R_{m+4,n+2}$
$n+3$	$B_{m-3,n+3}$	$C_{m-2,n+3}$	$B_{m-1,n+3}$	$C_{m,n+3}$	$B_{m+1,n+3}$	$C_{m+2,n+3}$	$B_{m+3,n+3}$	$C_{m+4,n+3}$
$n+4$	$C_{m-3,n+4}$	$R_{m-2,n+4}$	$C_{m-1,n+4}$	$R_{m,n+4}$	$C_{m+1,n+4}$	$R_{m+2,n+4}$	$C_{m+3,n+4}$	$R_{m+4,n+4}$

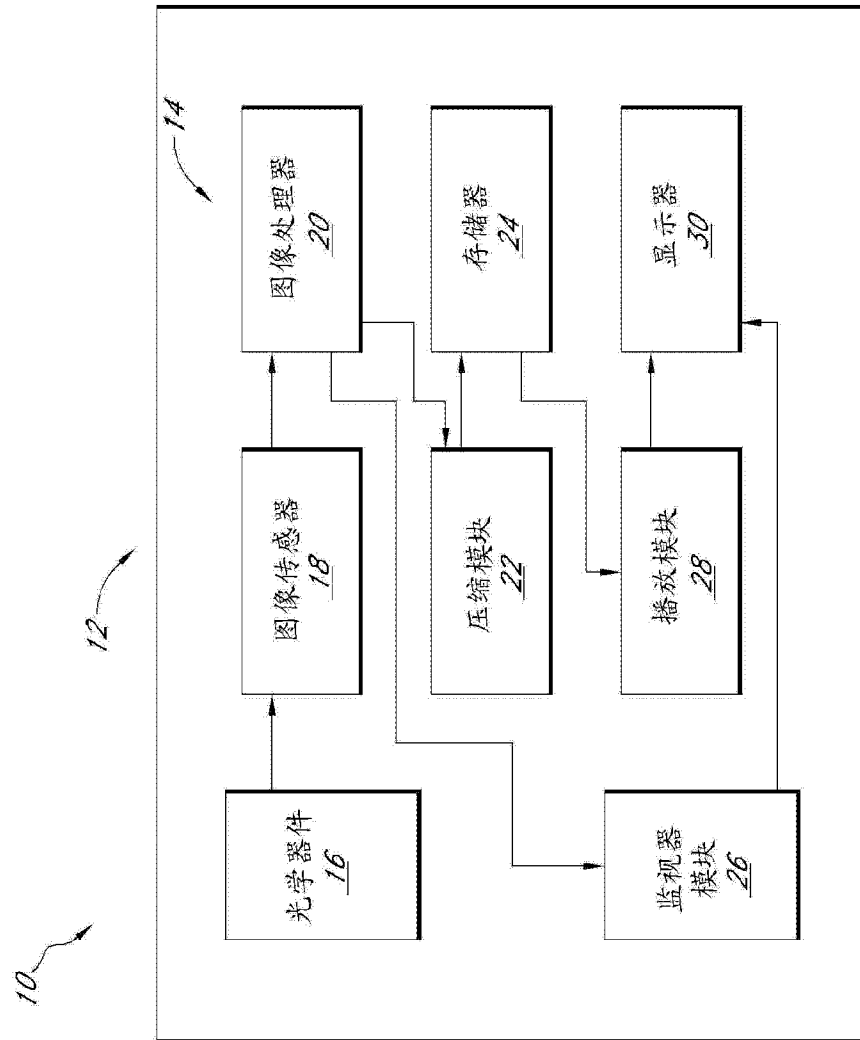
图 3

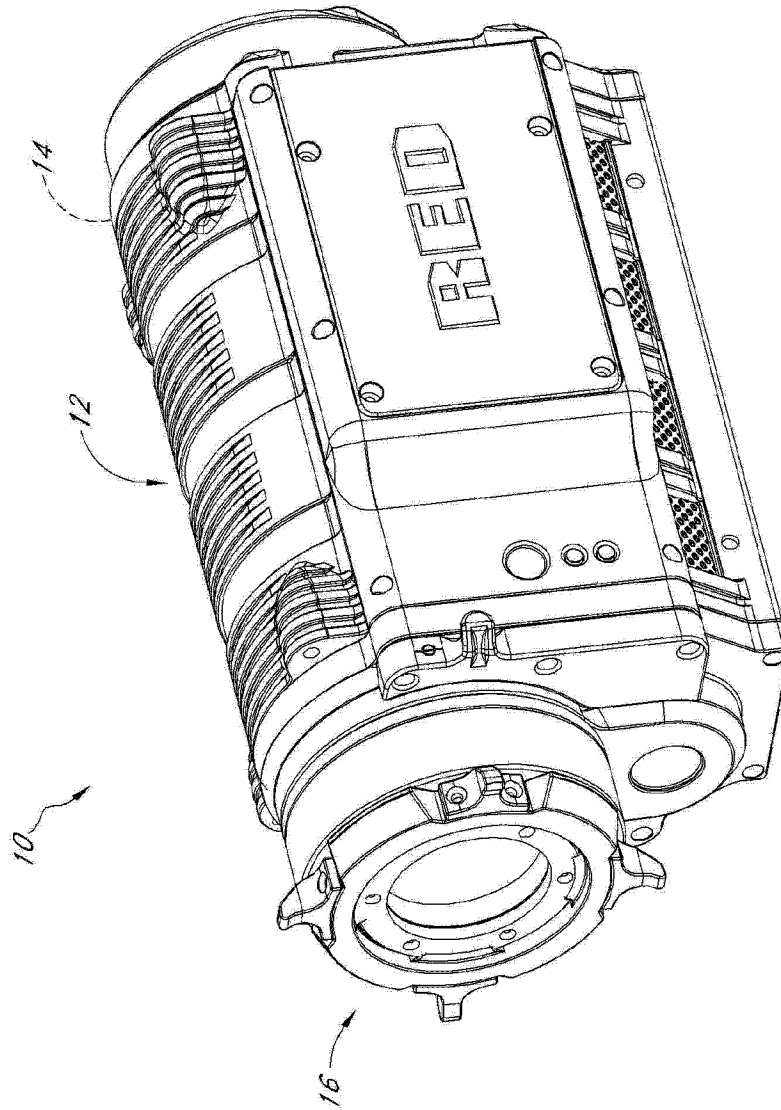

图 4

$n-3$	$m-3$	$m-2$	$m-1$	m	$m+1$	$m+2$	$m+3$	$m+4$
$n-2$	$C_{m-2,n-3}$	$C_{m-2,n-2}$	$C_{m-1,n-2}$	$C_{m,n-3}$	$C_{m+1,n-2}$	$C_{m+2,n-3}$	$C_{m+3,n-2}$	$C_{m+4,n-3}$
$n-1$	$C_{m-3,n-2}$	$C_{m-2,n-1}$	$C_{m,n-1}$	$C_{m,n-1}$	$C_{m+1,n-2}$	$C_{m+2,n-1}$	$C_{m+3,n-2}$	$C_{m+4,n-1}$
n	$C_{m-3,n}$	$C_{m-1,n}$	$C_{m-1,n}$	$C_{m,n+1}$	$C_{m+1,n}$	$C_{m+2,n+1}$	$C_{m+3,n}$	$C_{m+4,n+1}$
$n+1$	$C_{m-3,n+2}$	$C_{m-2,n+1}$	$C_{m-1,n+2}$	$C_{m,n+1}$	$C_{m+1,n+2}$	$C_{m+2,n+1}$	$C_{m+3,n+2}$	$C_{m+4,n+1}$
$n+2$	$C_{m-2,n+3}$	$C_{m-2,n+3}$	$C_{m-1,n+4}$	$C_{m,n+3}$	$C_{m+1,n+4}$	$C_{m+2,n+3}$	$C_{m+3,n+4}$	$C_{m+4,n+3}$
$n+3$	$C_{m-3,n+4}$	$C_{m-2,n+4}$	$C_{m-1,n+4}$	$C_{m,n+3}$	$C_{m+1,n+4}$	$C_{m+2,n+3}$	$C_{m+3,n+4}$	$C_{m+4,n+3}$
$n+4$	$C_{m-3,n+4}$	$C_{m-2,n+4}$	$C_{m-1,n+4}$	$C_{m,n+3}$	$C_{m+1,n+4}$	$C_{m+2,n+3}$	$C_{m+3,n+4}$	$C_{m+4,n+3}$

图 5

	$m+4$						
	$m+3$		$G_{m+3,n-2}$		$G_{m+3,n}$		$G_{m+3,n+2}$
	$m+2$						
	$m+1$		$G_{m+1,p-2}$		$G_{m+1,n}$		$G_{m+1,n+2}$
	m						
	$m-1$		$G_{m-1,p-2}$		$G_{m-1,n}$		$G_{m-1,n+2}$
	$m-2$						
	$m-3$		$G_{m-3,p-2}$		$G_{m-3,n}$		$G_{m-3,n+2}$
$n-3$							
$n-2$							
$n-1$							
n							
$n+1$							
$n+2$							
$n+3$							
$n+4$							

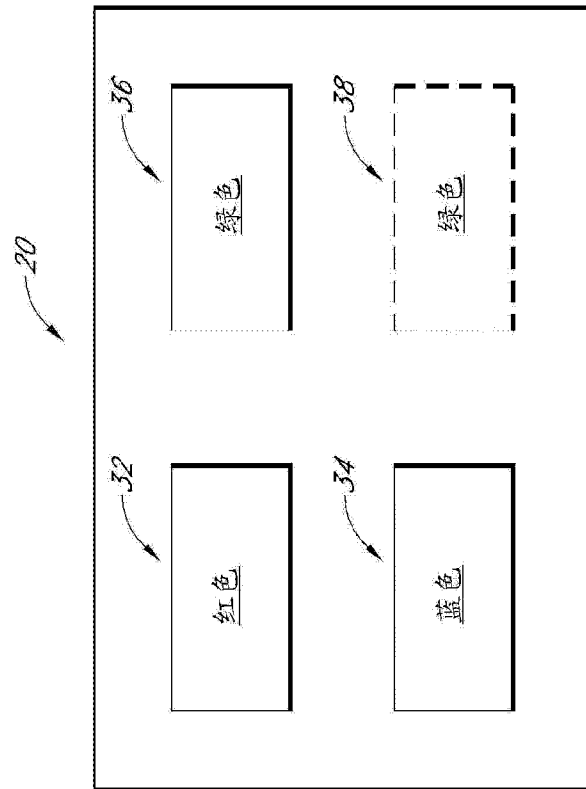
图 6



图 7



图 8

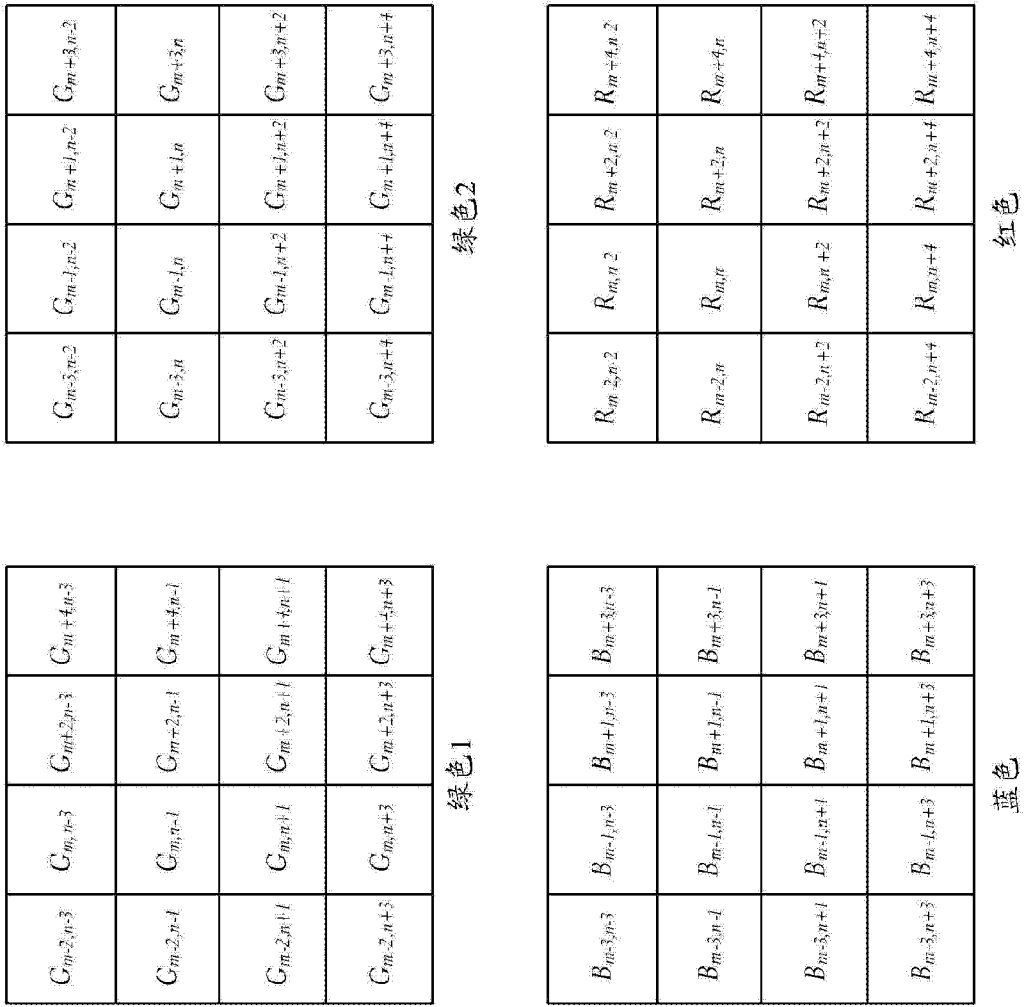

图 8A

	$B_{m-1, n-1}^i = \frac{B_{m-1, n-1}^i - (G_{m-1, n-2} + G_{m, n-1} + G_{m-1, n} + G_{m-2, n-1})/4}{4}$		

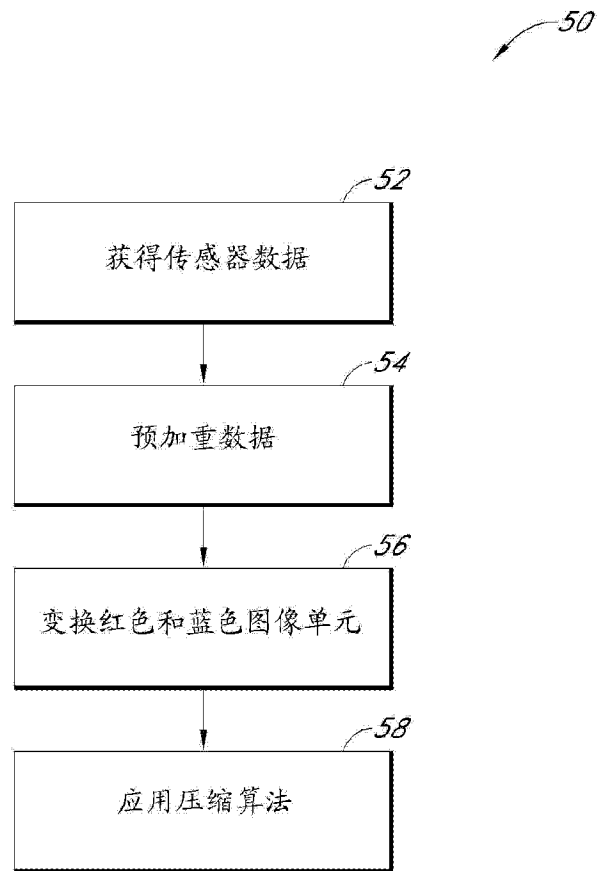
图 9

	$R'_{m-2, n-2} =$ $R_{m-2, n-2} -$ $(C_{m-2, n-3} + C_{m-1, n-2} +$ $C_{m-2, n-1} + C_{m-3, n-2})/4$		

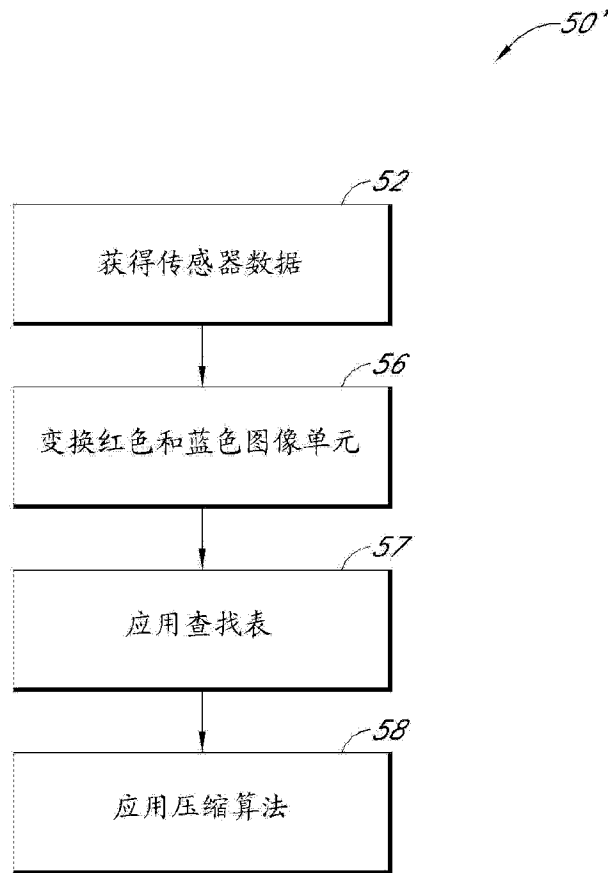
图 10



图 11



图 12

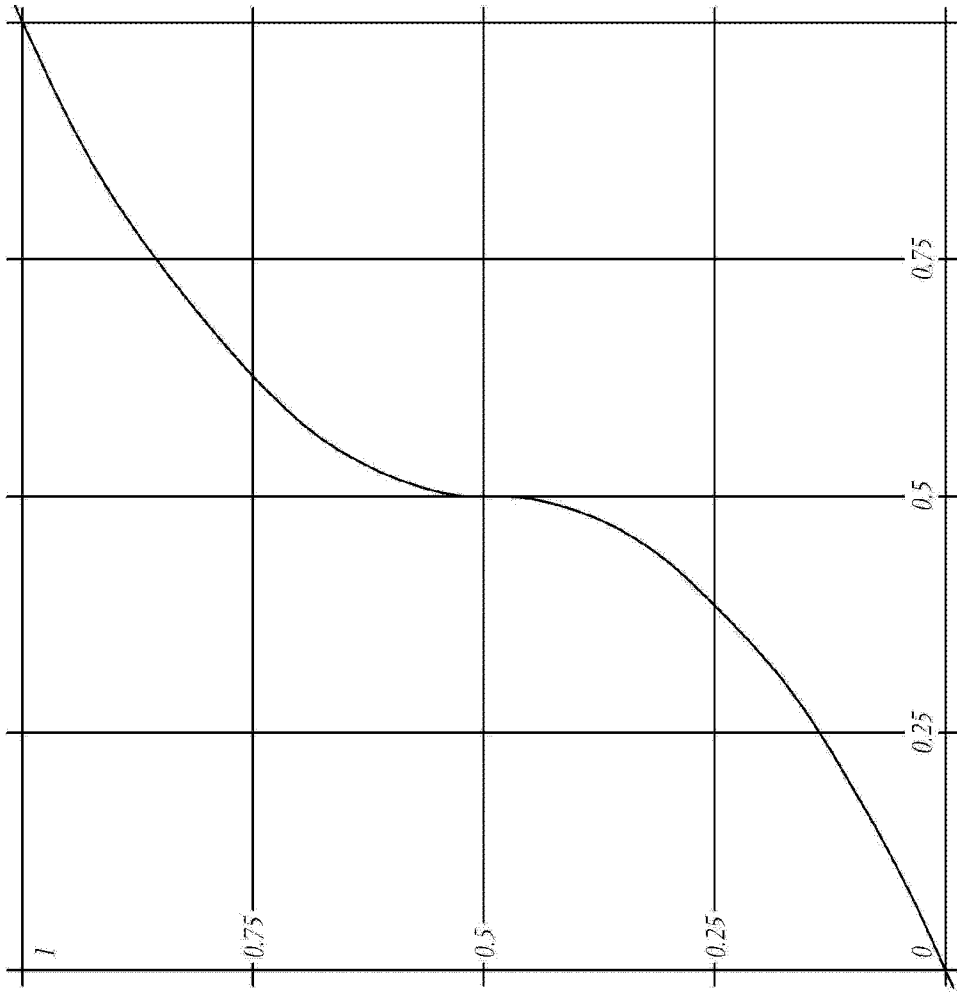

图 12A

	$m-3$	$m-2$	$m-1$	m	$m+1$	$m+2$	$m+3$	$m+4$
$n-3$	$DG_{m-3,n-3}$	$G_{m-2,n-3}$	$DG_{m-1,n-3}$	$G_{m,n-3}$	$DG_{m+1,n-3}$	$G_{m+2,n-3}$	$DG_{m+3,n-3}$	$G_{m+4,n-3}$
$n-2$	$G_{m-3,n-2}$	$DG_{m-2,n-2}$	$G_{m-1,n-2}$	$DG_{m,n-2}$	$G_{m+1,n-2}$	$DG_{m+2,n-2}$	$G_{m+3,n-2}$	$DG_{m+4,n-2}$
$n-1$	$DG_{m-3,n-1}$	$G_{m-2,n-1}$	$DG_{m-1,n-1}$	$G_{m,n-1}$	$DG_{m+1,n-1}$	$G_{m+2,n-1}$	$DG_{m+3,n-1}$	$G_{m+4,n-1}$
n	$G_{m-3,n}$	$DG_{m-2,n}$	$G_{m-1,n}$	$DG_{m,n}$	$G_{m+1,n}$	$DG_{m+2,n}$	$G_{m+3,n}$	$DG_{m+4,n}$
$n+1$	$DG_{m-3,n+1}$	$G_{m-2,n+1}$	$DG_{m-1,n+1}$	$G_{m,n+1}$	$DG_{m+1,n+1}$	$G_{m+2,n+1}$	$DG_{m+3,n+1}$	$G_{m+4,n+1}$
$n+2$	$G_{m-3,n+2}$	$DG_{m-2,n+2}$	$G_{m-1,n+2}$	$DG_{m,n+2}$	$G_{m+1,n+2}$	$DG_{m+2,n+2}$	$G_{m+3,n+2}$	$DG_{m+4,n+2}$
$n+3$	$DG_{m-3,n+3}$	$G_{m-2,n+3}$	$DG_{m-1,n+3}$	$G_{m,n+3}$	$DG_{m+1,n+3}$	$G_{m+2,n+3}$	$DG_{m+3,n+3}$	$G_{m+4,n+3}$
$n+4$	$G_{m-3,n+4}$	$DG_{m-2,n+4}$	$G_{m-1,n+4}$	$DG_{m,n+4}$	$G_{m+1,n+4}$	$DG_{m+2,n+4}$	$G_{m+3,n+4}$	$DG_{m+4,n+4}$

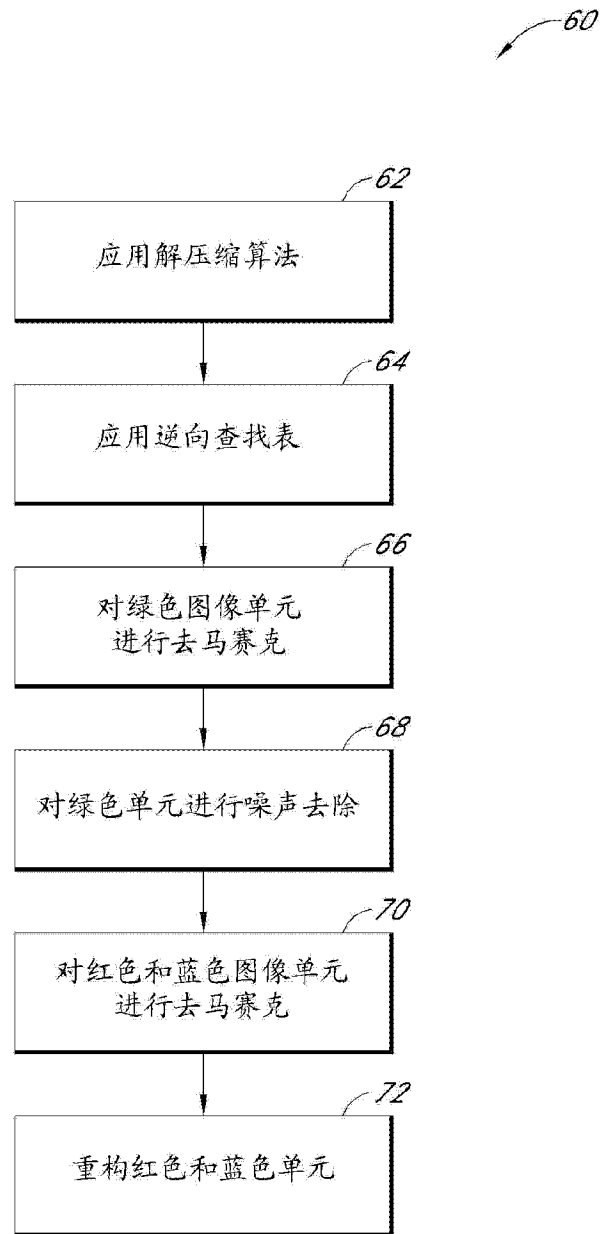
图 13

	$m-3$	$m-2$	$m-1$	m	$m+1$	$m+2$	$m+3$	$m+4$
$n-3$	$DG_{m-3,n-3}$	$DG_{m-2,n-3}$	$DG_{m-1,n-3}$	$DG_{m,n-3}$	$DG_{m+1,n-3}$	$DG_{m+2,n-3}$	$DG_{m+3,n-3}$	$DG_{m+4,n-3}$
$n-2$	$C_{m-3,n-2}$	$DG_{m-2,n-2}$	$C_{m-1,n-2}$	$DC_{m,n-2}$	$C_{m+1,n-2}$	$DC_{m+2,n-2}$	$C_{m+3,n-2}$	$DC_{m+4,n-2}$
$n-1$	$DG_{m-3,n-1}$	$DG_{m-2,n-1}$	$DC_{m-1,n-1}$	$DC_{m,n-1}$	$DG_{m+1,n-1}$	$DC_{m+2,n-1}$	$DC_{m+3,n-1}$	$DC_{m+4,n-1}$
n	$C_{m-3,n}$	$DC_{m-2,n}$	$C_{m-1,n}$	$DC_{m,n}$	$C_{m+1,n}$	$DC_{m+2,n}$	$C_{m+3,n}$	$DC_{m+4,n}$
$n+1$	$DC_{m-3,n+1}$	$DC_{m-2,n+1}$	$DC_{m-1,n+1}$	$DC_{m,n+1}$	$DC_{m+1,n+1}$	$DC_{m+2,n+1}$	$DC_{m+3,n+1}$	$DC_{m+4,n+1}$
$n+2$	$C_{m-3,n+2}$	$DC_{m-2,n+2}$	$C_{m-1,n+2}$	$DC_{m,n+2}$	$C_{m+1,n+2}$	$DC_{m+2,n+2}$	$C_{m+3,n+2}$	$DC_{m+4,n+2}$
$n+3$	$DC_{m-3,n+3}$	$DC_{m-2,n+3}$	$DC_{m-1,n+3}$	$DC_{m,n+3}$	$DC_{m+1,n+3}$	$DC_{m+2,n+3}$	$DC_{m+3,n+3}$	$DC_{m+4,n+3}$
$n+4$	$C_{m-3,n+4}$	$DC_{m-2,n+4}$	$C_{m-1,n+4}$	$DC_{m,n+4}$	$C_{m+1,n+4}$	$DC_{m+2,n+4}$	$C_{m+3,n+4}$	$DC_{m+4,n+4}$

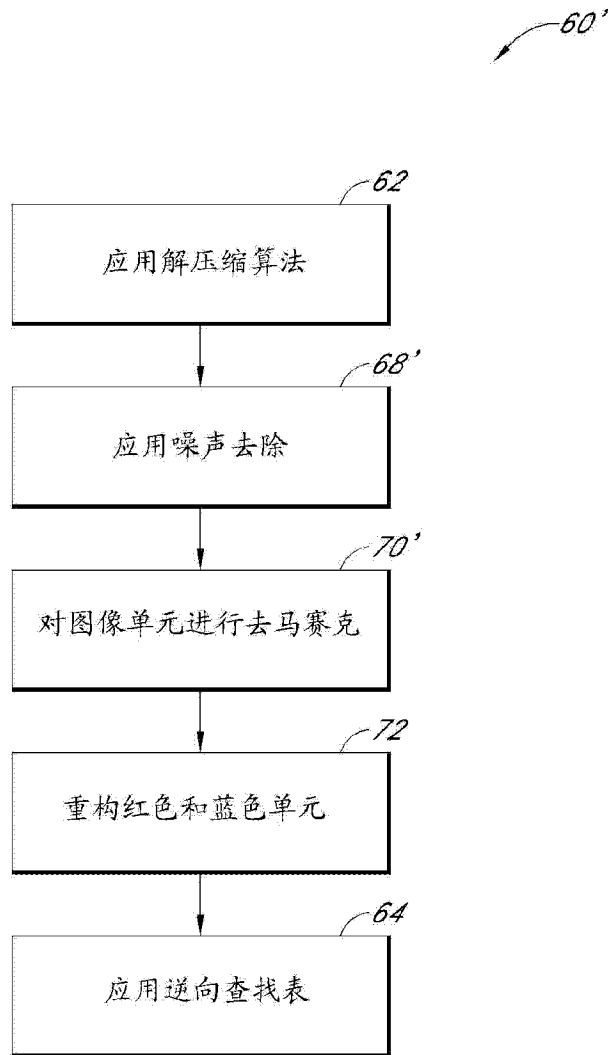
图 14

$m-3$	$B_{m-3,n-3}$		$B_{m-3,n-1}$		$B_{m-3,n+1}$		$B_{m-3,n+3}$
$m-2$							
$m-1$	$B_{m-1,n-3}$		$B_{m-1,n-1}$		$B_{m-1,n+1}$		$B_{m-1,n+3}$
m							
$m+1$	$B_{m+1,n-3}$						
$m+2$							
$m+3$	$B_{m+3,n-3}$		$B_{m+3,n-1}$		$B_{m+3,n+1}$		$B_{m+3,n+3}$
$m+4$							
$n-3$		$n-2$	$n-1$	n	$n+1$	$n+2$	$n+3$
							$n+4$

图 15

	$m-3$	$m-2$	$m-1$	m	$m+1$	$m+2$	$m+3$	$m+4$
$n-3$	$B_{m-3,n-3}$	$DB_{m-2,n-3}$	$B_{m-1,n-3}$	$DB_{m,n-3}$	$B_{m+1,n-3}$	$DB_{m+2,n-3}$	$B_{m+3,n-3}$	$DB_{m+4,n-3}$
$n-2$	$DB_{m-3,n-2}$	$DB_{m-2,n-2}$	$DB_{m-1,n-2}$	$DB_{m,n-2}$	$DB_{m+1,n-2}$	$DB_{m+2,n-2}$	$DB_{m+3,n-2}$	$DB_{m+4,n-2}$
$n-1$	$B_{m-3,n-1}$	$DB_{m-2,n-1}$	$B_{m-1,n-1}$	$DB_{m,n-1}$	$B_{m+1,n-1}$	$DB_{m+2,n-1}$	$B_{m+3,n-1}$	$DB_{m+4,n-1}$
n	$DB_{m-3,n}$	$DB_{m-2,n}$	$DB_{m-1,n}$	$DB_{m,n}$	$DB_{m+1,n}$	$DB_{m+2,n}$	$DB_{m+3,n}$	$DB_{m+4,n}$
$n+1$	$B_{m-3,n+1}$	$DB_{m-2,n+1}$	$B_{m-1,n+1}$	$DB_{m,n+1}$	$B_{m+1,n+1}$	$DB_{m+2,n+1}$	$B_{m+3,n+1}$	$DB_{m+4,n+1}$
$n+2$	$DB_{m-3,n+2}$	$DB_{m-2,n+2}$	$DB_{m-1,n+2}$	$DB_{m,n+2}$	$DB_{m+1,n+2}$	$DB_{m+2,n+2}$	$DB_{m+3,n+2}$	$DB_{m+4,n+2}$
$n+3$	$B_{m-3,n+3}$	$DB_{m-2,n+3}$	$B_{m-1,n+3}$	$DB_{m,n+3}$	$B_{m+1,n+3}$	$DB_{m+2,n+3}$	$B_{m+3,n+3}$	$DB_{m+4,n+3}$
$n+4$	$DB_{m-3,n+4}$	$DB_{m-2,n+4}$	$DB_{m-1,n+4}$	$DB_{m,n+4}$	$DB_{m+1,n+4}$	$DB_{m+2,n+4}$	$DB_{m+3,n+4}$	$DB_{m+4,n+4}$

图 16

INFORMATION DISCLOSURE STATEMENT

Inventor	: James H. Jannard
App. No.	: 14/485612
Filed	: September 12, 2014
For	: VIDEO CAMERA
Examiner	: Diep, Trung T.
Art Unit	: 2664
Conf. No.	: 1068

Mail Stop RCE

Commissioner for Patents
P.O. Box 1450
Alexandria, VA 22313-1450

References and Listing

Pursuant to 37 CFR 1.56, an Information Disclosure Statement listing references is provided herewith. Pursuant to 37 C.F.R § 1.97(g) and (h), Applicants make no representation that the information is considered to be material to patentability. Additionally, inclusion on this list is not an admission that any of the cited documents are prior art in this application. Further, Applicants make no representation regarding the completeness of this list, or that better art does not exist.

Applicant wishes to draw the Examiner's attention to the following applications owned by of the present application's assignee:

Docket No.	Serial No.	Patent/ Publication No	Title	Filed
REDCOM.007A	12/101,882	8,174,560	VIDEO CAMERA	04/11/2008
REDCOM.007CP1	12/422,507	8,237,830	VIDEO CAMERA	04/13/2009
REDCOM.007CP1C1	12/834,854	7,830,967	VIDEO CAMERA	07/12/2010
REDCOM.007C1	13/464,803	8,872,933	VIDEO CAMERA	05/04/2012
REDCOM.007C2	13/566,868	8,358,357	VIDEO CAMERA	08/03/2012
REDCOM.007CP1C2	13/566,924	8,878,952	VIDEO CAMERA	08/03/2012
REDCOM.007X1 (reexamination REDCOM.007A)	90/012,550	8,174,560 C1	VIDEO CAMERA	09/13/2012

Application No.: 14/485612
Filing Date: September 12, 2014

Docket No.	Serial No.	Patent/ Publication No	Title	Filed
REDCOM.007C3	14/485,611	2015/0003801	VIDEO CAMERA	09/12/2014
REDCOM.007P1C3	14/488,030	9,019,393	VIDEO PROCESSING SYSTEM AND METHOD	09/16/2014
REDCOM.007P1C4	14/609,090	N/A	VIDEO CAMERA	01/29/2015

Applicant notes that cited references, office actions, responses and notices of allowance currently exist or will exist for the above-referenced matters. Applicant also understands that the Examiner has access to sophisticated online Patent Office computing systems that provide ready access to the full file histories of these matters including, for example, specifications, drawings, pending claims, cited art, office actions, responses, declarations, and notices of allowance. Rather than submit copies these file histories, Applicant respectfully requests that the Examiner continue to review these file histories online for past, current, and future information about these matters. Also, if the Examiner cannot readily access these file histories, the Applicant would be pleased to provide any portion of any of the file histories at any time upon specific Examiner request.

No Disclaimers

To the extent that anything in the Information Disclosure Statement or the listed references could be construed as a disclaimer of any subject matter supported by the present application, Applicant hereby rescinds and retracts such disclaimer.

Timing of Disclosure

This Information Disclosure Statement is being filed with an RCE and no fee is believed to be required. The Commissioner is hereby authorized to charge any additional fees which may be required or to credit any overpayment to Account No. 11-1410.

Respectfully submitted,
KNOBBE, MARTENS, OLSON & BEAR, LLP

Dated: September 29, 2015

By: /Sean Ambrosius/ _____
Sean Ambrosius
Registration No. 65,290
Attorney of Record
Customer No. 20995
(949) 760-0404

21657852

IN THE UNITED STATES PATENT AND TRADEMARK OFFICE

Inventor	: James H. Jannard
App. No.	: 14/485612
Filed	: September 12, 2014
For	: VIDEO CAMERA
Examiner	: Diep, Trung T.
Art Unit	: 2664
Conf. No.	: 1068

PETITION UNDER 37 CFR 1.182 TO EXPEDITE THE PROCESSING OF A PREVIOUSLY
FILED PETITION

Mail Stop Petition

Commissioner for Patents
P.O. Box 1450
Alexandria, VA 22313-1450

Applicant submits this petition under 37 C.F.R. § 1.182 to expedite the processing of the following previously filed petition, which was filed on September 29, 2015: *Petition to Expunge Information Unintentionally Submitted in an Application Under 37 CFR § 1.59*. The petition fee set forth in 37 C.F.R. § 1.17(f) is submitted herewith.

The Commissioner is hereby authorized to charge the fee set 37 C.F.R. § 1.17(f), and any other necessary fees, including any fees for additional extension of time, which may be required, now or in the future, or credit any overpayment to Deposit Account No. 11-1410. If there are any obstacles to a prompt approval of this petition, the Patent and Trademark Office is invited to call the undersigned attorney.

Respectfully submitted,

KNOBBE, MARTENS, OLSON & BEAR, LLP

Dated: 10/13/2015 _____ By: /Sean Ambrosius/ _____
Sean P. Ambrosius
Registration No. 65,290
Attorney of Record
Customer No. 20,995
(949) 760-0404

Electronic Patent Application Fee Transmittal

Application Number:	14485612
Filing Date:	12-Sep-2014
Title of Invention:	VIDEO CAMERA
First Named Inventor/Applicant Name:	James H. Jannard
Filer:	Sean Patrick Ambrosius/Daniella Kellogg
Attorney Docket Number:	REDCOM.007C4

Filed as Large Entity

Filing Fees for Utility under 35 USC 111(a)

Description	Fee Code	Quantity	Amount	Sub-Total in USD(\$)
Basic Filing:				
Pages:				
Claims:				
Miscellaneous-Filing:				
Petition:				
Petition fee- 37 CFR 1.17(f) (Group I)	1462	1	400	400

Patent-Appeals-and-Interference:

Post-Allowance-and-Post-Issuance:

Description	Fee Code	Quantity	Amount	Sub-Total in USD(\$)
Extension-of-Time:				
Miscellaneous:				
Total in USD (\$)				400

Electronic Acknowledgement Receipt

EFS ID:	23766941
Application Number:	14485612
International Application Number:	
Confirmation Number:	1068
Title of Invention:	VIDEO CAMERA
First Named Inventor/Applicant Name:	James H. Jannard
Customer Number:	20995
Filer:	Sean Patrick Ambrosius/Heide Young
Filer Authorized By:	Sean Patrick Ambrosius
Attorney Docket Number:	REDCOM.007C4
Receipt Date:	13-OCT-2015
Filing Date:	12-SEP-2014
Time Stamp:	18:03:29
Application Type:	Utility under 35 USC 111(a)

Payment information:

Submitted with Payment	yes
Payment Type	Credit Card
Payment was successfully received in RAM	\$400
RAM confirmation Number	5579
Deposit Account	111410
Authorized User	KNOBBE MARTENS OLSON AND BEAR

The Director of the USPTO is hereby authorized to charge indicated fees and credit any overpayment as follows:

Charge any Additional Fees required under 37 C.F.R. Section 1.16 (National application filing, search, and examination fees)

Charge any Additional Fees required under 37 C.F.R. Section 1.17 (Patent application and reexamination processing fees)

--	--	--	--	--	--

File Listing:

Document Number	Document Description	File Name	File Size(Bytes)/ Message Digest	Multi Part /.zip	Pages (if appl.)
1	Petition for review by the Office of Petitions	PETITION_REDCOM-007C4.pdf	23210 0acde97c50d60b5c09fefee5810dbda69c003cc3	no	1

Warnings:

Information:

2	Fee Worksheet (SB06)	fee-info.pdf	30517 b47c4d209976f966e835021735e49d882b6dca9	no	2
---	----------------------	--------------	--	----	---

Warnings:

Information:

Total Files Size (in bytes):			53727		
-------------------------------------	--	--	-------	--	--

This Acknowledgement Receipt evidences receipt on the noted date by the USPTO of the indicated documents, characterized by the applicant, and including page counts, where applicable. It serves as evidence of receipt similar to a Post Card, as described in MPEP 503.

New Applications Under 35 U.S.C. 111

If a new application is being filed and the application includes the necessary components for a filing date (see 37 CFR 1.53(b)-(d) and MPEP 506), a Filing Receipt (37 CFR 1.54) will be issued in due course and the date shown on this Acknowledgement Receipt will establish the filing date of the application.

National Stage of an International Application under 35 U.S.C. 371

If a timely submission to enter the national stage of an international application is compliant with the conditions of 35 U.S.C. 371 and other applicable requirements a Form PCT/DO/EO/903 indicating acceptance of the application as a national stage submission under 35 U.S.C. 371 will be issued in addition to the Filing Receipt, in due course.

New International Application Filed with the USPTO as a Receiving Office

If a new international application is being filed and the international application includes the necessary components for an international filing date (see PCT Article 11 and MPEP 1810), a Notification of the International Application Number and of the International Filing Date (Form PCT/RO/105) will be issued in due course, subject to prescriptions concerning national security, and the date shown on this Acknowledgement Receipt will establish the international filing date of the application.



UNITED STATES PATENT AND TRADEMARK OFFICE

UNITED STATES DEPARTMENT OF COMMERCE
United States Patent and Trademark Office
Address: COMMISSIONER FOR PATENTS
P.O. Box 1450
Alexandria, Virginia 22313-1450
www.uspto.gov

Table with 5 columns: APPLICATION NO., FILING DATE, FIRST NAMED INVENTOR, ATTORNEY DOCKET NO., CONFIRMATION NO.
14/485,612 09/12/2014 James H. Jannard REDCOM.007C4 1068

20995 7590 11/12/2015
KNOBBE MARTENS OLSON & BEAR LLP
2040 MAIN STREET
FOURTEENTH FLOOR
IRVINE, CA 92614

EXAMINER

DIEP, TRUNG T

ART UNIT PAPER NUMBER

2664

NOTIFICATION DATE DELIVERY MODE

11/12/2015

ELECTRONIC

Please find below and/or attached an Office communication concerning this application or proceeding.

The time period for reply, if any, is set in the attached communication.

Notice of the Office communication was sent electronically on above-indicated "Notification Date" to the following e-mail address(es):

jayna.cartee@knobbe.com
efiling@knobbe.com



KNOBBE MARTENS OLSON & BEAR LLP
2040 MAIN STREET
FOURTEENTH FLOOR
IRVINE, CA 92614

In Re Application of :
Jannard, JAMES H. et al. :
Application Serial No. 14/485,612 :
Filed: September 12, 2014 :
For: **VIDEO CAMERA** :

DECISION ON PETITION
TO EXPUNGE

This is a response to the petition filed September 29, 2015 under 37 CFR 1.59(b) and 724.05(II), to expunge information from the above identified application.

Petitioner requests that at least pages 2-4 of the submitted 7 page document contained in the Information Disclosure Statement filed on May 18, 2015 (listed as Cite No. 41) be expunged from the record because it contained unintentionally submitted confidential and proprietary information.

MPEP 724.05(II) states in part:

A petition to expunge information unintentionally submitted in an application (other than information forming part of the original disclosure) may be filed under 37 CFR 1.59(b), provided that:

- (A) the Office can effect such return prior to the issuance of any patent on the application in issue;
- (B) it is stated that the information submitted was unintentionally submitted and the failure to obtain its return would cause irreparable harm to the party who submitted the information or to the party in interest on whose behalf the information was submitted;
- (C) the information has not otherwise been made public;
- (D) there is a commitment on the part of the petitioner to retain such information for the period of any patent with regard to which such information is submitted;
- (E) it is established to the satisfaction of the Commissioner that the information to be returned is not material information under 37 CFR 1.56; and
- (F) the petition fee as set forth in 37 CFR 1.17(g) is included.

Petitioner has complied with parts A-F above.

The entire 7 page document has been closed from the electronic file.

Accordingly the petition is **GRANTED**.

/Kenneth A. Wieder/

Kenneth A. Wieder
Quality Assurance Specialist
Technology Center 2600
Communications

INFORMATION DISCLOSURE STATEMENT BY APPLICANT	Application No.	14/485612
	Filing Date	September 12, 2014
	First Named Inventor	James H. Jannard
	Art Unit	2664
<i>(Multiple sheets used when necessary)</i>	Examiner	Diep, Trung T.
SHEET 1 OF 1	Attorney Docket No.	REDCOM.007C4

U.S. PATENT DOCUMENTS					
Examiner Initials	Cite No.	Document Number <i>Number - Kind Code (if known)</i> Example: 1,234,567 B1	Publication Date MM-DD-YYYY	Name	Pages, Columns, Lines Where Relevant Passages or Relevant Figures Appear
	1	2004/0032516	02-19-2004	Kakarala	
	2	U.S. Patent Application No. 14/609090 as filed January 29, 2015 (and entire prosecution history) (REDCOM.007P1C4)	N/A	Jannard et al.	

FOREIGN PATENT DOCUMENTS						
Examiner Initials	Cite No.	Foreign Patent Document <i>Country Code-Number-Kind Code</i> Example: JP 1234567 A1	Publication Date MM-DD-YYYY	Name	Pages, Columns, Lines Where Relevant Passages or Relevant Figures Appear	T ¹
	3	WO 2014/127153 (REDCOM.084WO)	08-21-2014	Red.com, Inc.		

NON PATENT LITERATURE DOCUMENTS			
Examiner Initials	Cite No.	Include name of the author (in CAPITAL LETTERS), title of the article (when appropriate), title of the item (book, magazine, journal, serial, symposium, catalog, etc.), date, page(s), volume-issue number(s), publisher, city and/or country where published.	T ¹

22140438

Examiner Signature	Date Considered
<p>*Examiner: Initial if reference considered, whether or not citation is in conformance with MPEP 609. Draw line through citation if not in conformance and not considered. Include copy of this form with next communication to applicant.</p>	

T¹ - Place a check mark in this area when an English language Translation is attached.



- (51) **International Patent Classification:**
H04N 9/07 (2006.01) *H04N 9/64* (2006.01)
- (21) **International Application Number:**
PCT/US2014/016301
- (22) **International Filing Date:**
13 February 2014 (13.02.2014)
- (25) **Filing Language:** English
- (26) **Publication Language:** English
- (30) **Priority Data:**
61/764,821 14 February 2013 (14.02.2013) US
61/778,325 12 March 2013 (12.03.2013) US
- (71) **Applicant:** RED. COM, INC. [US/US]; 34 Parker, Irvine, CA 92618 (US).
- (72) **Inventors:** JANNARD, James, H.; 15 Wild Ridge, Las Vegas, NV 89135 (US). NATTRESS, Thomas, Graeme; 41 Bower St., Acton, ON L7J 1E1 (CA). GREENE, Richard; 9213 Bluegrass Dr., Austin, TX 78759 (US). MATHUR, Uday; 530 S. Barrington Ave. Apt. #202, Los Angeles, CA 90049 (US).
- (74) **Agent:** DELANEY, Karoline, A.; Knobbe, Martens, Olson & Bear, LLP, 2040 Main Street, 14th Floor, Irvine, CA 92614 (US).
- (81) **Designated States** (unless otherwise indicated, for every kind of national protection available): AE, AG, AL, AM, AO, AT, AU, AZ, BA, BB, BG, BH, BN, BR, BW, BY,

BZ, CA, CH, CL, CN, CO, CR, CU, CZ, DE, DK, DM, DO, DZ, EC, EE, EG, ES, FI, GB, GD, GE, GH, GM, GT, HN, HR, HU, ID, IL, IN, IR, IS, JP, KE, KG, KN, KP, KR, KZ, LA, LC, LK, LR, LS, LT, LU, LY, MA, MD, ME, MG, MK, MN, MW, MX, MY, MZ, NA, NG, NI, NO, NZ, OM, PA, PE, PG, PH, PL, PT, QA, RO, RS, RU, RW, SA, SC, SD, SE, SG, SK, SL, SM, ST, SV, SY, TH, TJ, TM, TN, TR, TT, TZ, UA, UG, US, UZ, VC, VN, ZA, ZM, ZW.

(84) **Designated States** (unless otherwise indicated, for every kind of regional protection available): ARIPO (BW, GH, GM, KE, LR, LS, MW, MZ, NA, RW, SD, SL, SZ, TZ, UG, ZM, ZW), Eurasian (AM, AZ, BY, KG, KZ, RU, TJ, TM), European (AL, AT, BE, BG, CH, CY, CZ, DE, DK, EE, ES, FI, FR, GB, GR, HR, HU, IE, IS, IT, LT, LU, LV, MC, MK, MT, NL, NO, PL, PT, RO, RS, SE, SI, SK, SM, TR), OAPI (BF, BJ, CF, CG, CI, CM, GA, GN, GQ, GW, KM, ML, MR, NE, SN, TD, TG).

Declarations under Rule 4.17:

- as to applicant's entitlement to apply for and be granted a patent (Rule 4.17(ii))
- as to the applicant's entitlement to claim the priority of the earlier application (Rule 4.17(iii))

Published:

- with international search report (Art. 21(3))

(54) **Title:** VIDEO CAMERA

		$m-3$	$m-2$	$m-1$	n	$m+1$	$m+2$	$m+3$	$m+4$
GREEN 1	$n-3$		$G_{m-2,n-3}$		$G_{m,n-3}$		$G_{m+2,n-3}$		$G_{m+4,n-3}$
GREEN 2	$n-2$		$G_{m-3,n-2}$		$G_{m-1,n-2}$		$G_{m+1,n-2}$		$G_{m+3,n-2}$
GREEN 1	$n-1$	181	$G_{m-2,n-1}$	182	$G_{m,n-1}$		$G_{m+2,n-1}$		$G_{m+4,n-1}$
GREEN 2	n		180	$G_{m-1,n}$		$G_{m+1,n}$		$G_{m+3,n}$	
GREEN 1	$n+1$	184	$G_{m-2,n+1}$	183	$G_{m,n+1}$		$G_{m+2,n+1}$		$G_{m+4,n+1}$
GREEN 2	$n+2$		$G_{m-3,n+2}$		$G_{m-1,n+2}$		$G_{m+1,n+2}$		$G_{m+3,n+2}$
GREEN 1	$n+3$		$G_{m-2,n+3}$		$G_{m,n+3}$		$G_{m+2,n+3}$		$G_{m+4,n+3}$
GREEN 2	$n+4$		$G_{m-3,n+4}$		$G_{m-1,n+4}$		$G_{m+1,n+4}$		$G_{m+3,n+4}$

FIG. 17

(57) **Abstract:** Embodiments provide a video camera that can be configured to highly compress video data in a visually lossless manner. The camera can be configured to transform blue, red, and/or green image data in a manner that enhances the compressibility of the data. The camera can be configured to transform at least a portion of the green image data in a manner that enhances the compressibility of the data. The data can then be compressed and stored in this form. This allows a user to reconstruct the red, blue, and/or green image data to obtain the original raw data or a modified version of the original raw data that is visually lossless when demosaiced. Additionally, the data can be processed in a manner in which at least some of the green image elements are demosaiced first and then the red, blue, and/or some green elements are reconstructed based on values of the demosaiced green image elements.

WO 2014/127153 A1

VIDEO CAMERA

CROSS-REFERENCE TO RELATED APPLICATIONS

[0001] This application claims priority benefit under 35 U.S.C. § 119(e) from U.S. Provisional Application Nos. 61/764,821, filed February 14, 2013, and 61/778,325, filed March 12, 2013. The disclosures of each of the foregoing applications are hereby incorporated by reference herein in their entirety.

BACKGROUND

Field of the Inventions

[0002] The present inventions are directed to digital cameras, such as those for capturing still or moving pictures, and more particularly, to digital cameras that compress image data.

SUMMARY

[0003] Although some currently available digital video cameras include high resolution image sensors, and thus output high resolution video, the image processing and compression techniques used on board such cameras may be too lossy and thus may eliminate too much raw image data to be acceptable in the high end portions of the market noted above. An aspect of at least one of the embodiments disclosed herein includes the realization that video quality that is acceptable for the higher end portions of the markets noted above, such as the major motion picture market, can be satisfied by cameras that can capture, compress and store raw or substantially raw video data at cinema-quality resolution and frame rates, such as at a resolution of at least about 2k or at least about 4k, and at a frame rate of at least about 23 frames per second. Examples of compressed raw data compression systems and methods are described in U.S. Patent No. 8,174,560, which is incorporated by reference in its entirety herein.

[0004] Another aspect of various embodiments of the present disclosure includes the realization that because the human eye is more sensitive to green wavelengths than any other color, green image data based modification of image data output from an image sensor

can be used to enhance compressibility of the data, yet provide a high quality video image. One such technique can include subtracting the magnitude of green light detected from the magnitudes of red and/or blue light detected prior to compressing the data. For instance, as discussed further herein, red and/or blue image data in a mosaiced (e.g., Bayer pattern) image data set can be modified based on green data in the mosaiced image data set. This can convert the red and/or blue image data into a more compressible form.

[0005] A further aspect of various embodiments of the present disclosure includes the realization that a first portion of the green image data may be used to modify a second portion of the green image data to improve compression. For example, mosaiced, raw image data (e.g., Bayer pattern image data or image data filtered using another type of color filter array [CFA]) may be composed of two green channels in addition to a red and a blue channel. As described above, green channel data may be subtracted from each of the blue and red channels to improve compressibility of the image data with little or no visual loss. According to various embodiments, this improved compressibility is possible, at least in part, because the color and/or intensity of the red and blue channels are correlated with the color and/or intensity of green channels. Accordingly, subtracting green channel data from red and/or blue channel data according to the techniques described herein may de-correlate a portion of the color and/or intensity data, improving compressibility.

[0006] According to some implementations, green image data may be modified based on other green image data, e.g., in order to improve compressibility. For instance, for Bayer pattern data, the first green channel can be used to predict a second green channel. For instance, data of a first green channel may be subtracted from data of a second green channel, and the difference or residual can be encoded, improving compressibility of the image data with little or no visual loss. Subtracting first green channel data from second green channel data may also improve compressibility as the first and second green channels may be spatially correlated with one another. Accordingly, subtracting the first green channel data from the second green channel data may also at least partially decorrelate the green image data, further improving compressibility. Moreover, green image data inherently contain more of the image detail than the red and blue planes. Embodiments described herein at least partly evolved from the realization that, using a carefully designed algorithm such as any of the ones described

herein, encoding one green channel using another green channel can be done to improve compression, while still preserving an acceptable level of image detail to achieve cinema quality compressed raw image data. According to certain implementations, this modification of the green image data can be done in conjunction with any of the red/blue data modification techniques in order to further improve compressibility of the image data. In some other implementations, the green data modification is done instead of red/blue data modification.

[0007] Further, similar to the description above, the process of green image data subtraction from blue, red, and/or other green image data, can be reversed following application of lossy compression algorithms (e.g., at compression ratios of at least 3, 4, 5, 6, 7, 8, 9, 10, 11, or 12 to 1, or higher), depending on the embodiment. Moreover, the resulting system and method incorporating such a technique can provide visually lossless video image data with enhanced compressibility of such video image data.

[0008] According to an embodiment, a method of compressing mosaiced color image data is disclosed comprising: accessing mosaiced color image data acquired by one or more image sensors of a video camera, the mosaiced color image data comprising a plurality of picture element values for each of a plurality of spatially interleaved color channels, the spatially interleaved color channels comprising a first green color channel, a second green color channel, a red color channel, and a blue color channel; transforming the second green color channel at least partly by, for each respective picture element of a plurality of picture elements of the second green color channel, modifying an initial value corresponding to the respective picture element using a calculated value derived from values of a plurality of picture elements of the first green color channel that are in spatial proximity to the respective picture element; compressing the transformed second green color channel; and storing the transformed, compressed second green color in at least one memory device of the video camera along with compressed versions of the first green color channel, the red color channel, and the blue color channel.

[0009] According to an aspect, said transforming comprises subtracting the calculated value from the initial value.

[0010] According to another aspect, the calculated value comprises an average of the values of the plurality of picture elements of the first green color channel that are in spatial proximity to the respective picture element.

[0011] According to yet another aspect, the plurality of picture elements of the first green color channel in spatial proximity to the respective picture element comprise at least two picture elements which are diagonally adjacent to the respective picture element.

[0012] According to another aspect, the at least two picture elements include four picture elements of the first green color channel which are diagonally adjacent to the respective picture element.

[0013] According to yet another aspect, the plurality of picture elements of the first green color channel which are in spatial proximity to the respective picture element include at least two picture elements, further wherein the respective picture element is positioned between the at least two picture elements.

[0014] According to another aspect, the at least two picture elements include two picture elements which are diagonally opposite one another with respect to the respective picture element.

[0015] According to yet another aspect, the at least two picture elements include a first pair of picture elements which are diagonally opposite one another with respect to the respective picture element and a second pair of picture elements which are diagonally opposite one another with respect to the respective picture element.

[0016] According to another aspect, the at least two picture elements are diagonally adjacent to the respective picture element.

[0017] According to yet another aspect, the plurality of picture elements of the first green color which are in spatial proximity to the respective picture element include at least three picture elements.

[0018] According to another aspect, the color image data is mosaiced according to a Bayer pattern.

[0019] According to yet another aspect, said transforming results in a spatial decorrelation of the first green color channel from the second green color channel.

[0020] According to another aspect, the method further comprises compressing the first green color channel and storing the compressed first green color channel in the at least one memory device.

[0021] According to yet another aspect, the method further comprises: transforming the red color channel by subtracting from respective picture element values of the red color channel a calculated value derived from picture element values of one or more of the first green color channel and the second green color channel which are in spatial proximity to the respective picture element values of the red color channel; compressing the transformed red color channel; transforming the blue color channel by subtracting from respective picture element values of the blue color channel a calculated value derived from picture element values of one or more of the first green color channel and the second green color channel which are in spatial proximity to the respective picture element values of the blue color channel; compressing the transformed blue color channel; and storing the transformed, compressed red and blue color channels in the at least one memory device.

[0022] According to another aspect, said transforming results in a spatial decorrelation of one or more of the first and second green color channels from the red and blue color channels.

[0023] According to another embodiment, a video camera is disclosed comprising: at least one memory device; one or more image sensors configured to convert light incident on the image sensor into color image data, the color image data mosaiced according to a pattern and comprising a plurality of picture element values for each of a plurality of spatially interleaved color channels, the spatially interleaved color channels comprising a first green color channel, a second green color channel, a red color channel, and a blue color channel; and an image processing module configured to: transform the second green color channel at least partly by, for each respective picture element of a plurality of picture elements of the second green color channel, modifying an initial value corresponding to the respective picture element using a calculated value derived from values of a plurality of picture elements of the first green color channel that are in spatial proximity to the respective picture element; compress the transformed second green color channel; and store the transformed, compressed second green color in the memory device.

[0024] According to yet another embodiment, an apparatus for processing mosaiced color image data is disclosed comprising: at least one memory device; one or more processors; and an image processing module executing in the one or more processors and configured to: access color image data from the memory device, the color image data comprising a plurality of picture element values for each of a plurality of spatially interleaved color channels, the spatially interleaved color channels comprising a first green color channel, a second green color channel, a red color channel, and a blue color channel; and transform the second green color channel at least partly by, for each respective picture element of a plurality of picture elements of the second green color channel, modifying an initial value corresponding to the respective picture element using a calculated value derived from values of a plurality of picture elements of the first green color channel that are in spatial proximity to the respective picture element; and compress the transformed second green color channel.

[0025] According to another embodiment, a method of decoding color image data is disclosed comprising: accessing encoded color image data for a second green color channel of a plurality of color channels of the color image data, wherein the encoded, color image data was encoded at least partly by: transforming the second green color channel least partly by, for each respective picture element of a plurality of picture elements of the second green color channel, modifying an initial value corresponding to the respective picture element using a calculated value derived from values of a plurality of picture elements of a first green color channel of the plurality of color channels, the plurality of picture elements of the first green channel in spatial proximity to the respective picture element; and compressing the transformed second green color channel; and decoding the accessed color image data for the second green color channel.

[0026] According to an aspect, the decoding comprises substantially reversing the transform operation and performing a decompression operation.

[0027] According to another aspect, substantially reversing the transform operation is performed after performing the decompression operation.

[0028] According to yet another aspect, substantially reversing the transform operation is performed prior to performing the decompression operation.

BRIEF DESCRIPTION OF THE DRAWINGS

[0029] Figure 1 is a block diagram illustrating a system that can include hardware and/or can be configured to perform methods for processing video image data in accordance with an embodiment.

[0030] Figure 2 is an optional embodiment of a housing for the camera schematically illustrated in Figure 1, according to an embodiment.

[0031] Figure 3 is a schematic layout of an image sensor having a Bayer Pattern Filter that can be used with the system illustrated in Figure 1, according to various embodiments.

[0032] Figure 4 is a schematic block diagram of an image processing module that can be used in the system illustrated in Figure 1, according to various embodiments.

[0033] Figure 5 is a schematic layout of the green image data from the green sensor cells of the image sensor of Figure 3, according to various embodiments.

[0034] Figure 6 is a schematic layout of the remaining green image data of Figure 5 after an optional process of deleting some of the original green image data, according to various embodiments.

[0035] Figure 7 is a schematic layout of the red, blue, and green image data of Figure 5 organized for processing in the image processing module of Figure 1, according to various embodiments.

[0036] Figure 8 is a flowchart illustrating an image data transformation technique that can be used with the system illustrated in Figure 1, according to various embodiments.

[0037] Figure 8A is a flowchart illustrating a modification of the image data transformation technique of Figure 8 that can also be used with the system illustrated in Figure 1, according to various embodiments.

[0038] Figure 9 is a schematic layout of blue image data resulting from an image transformation process of Figure 8, according to various embodiments.

[0039] Figure 10 is a schematic layout of red image data resulting from an image transformation process of Figure 8, according to various embodiments.

[0040] Figure 11 illustrates an exemplary optional transform that can be applied to the image data for gamma correction, according to various embodiments.

[0041] Figure 12 is a flowchart of a control routine that can be used with the system of Figure 1 to decompress and demosaic image data, according to various embodiments.

[0042] Figure 12A is a flowchart illustrating a modification of the control routine of Figure 12 that can also be used with the system illustrated in Figure 1, according to various embodiments.

[0043] Figure 13 is a schematic layout of green image data having been decompressed and demosaiced according to the flowchart of Figure 12, according to various embodiments.

[0044] Figure 14 is a schematic layout of half of the original green image data from Figure 13, having been decompressed and demosaiced according to the flowchart of Figure 12, according to various embodiments.

[0045] Figure 15 is a schematic layout of blue image data having been decompressed according to the flowchart of Figure 12, according to various embodiments.

[0046] Figure 16 is a schematic layout of blue image data of Figure 15 having been demosaiced according to the flowchart of Figure 12, according to various embodiments.

[0047] Figure 17 shows an example of an application of an image transformation process involving green image data modification and including neighboring pixel selection, according to various embodiments.

[0048] Figure 18 is a flowchart illustrating an image data transformation technique involving the modification of green image data that can be used with the system illustrated in Figure 1, according to various embodiments.

[0049] Figure 19 is an example of an application of an image transformation process including neighboring pixel selection, for image data at an edge of an image, according to various embodiments.

[0050] Figure 20 is a flowchart of a control routine that can be used with the system of Figure 1 to decompress and reconstruct image data, according to various embodiments.

[0051] Figure 21 illustrates an example subsystem for reversing an image data transformation technique according to certain embodiments, according to various embodiments.

DETAILED DESCRIPTION

[0052] Figure 1 is a schematic diagram of a camera having image sensing, processing, and compression modules, described in the context of a video camera for moving pictures. The embodiments disclosed herein are described in the context of a video camera having a single sensor device with a Bayer pattern filter because these embodiments have particular utility in this context. However, the embodiments and inventions herein can also be applied to cameras having other types of image sensors (e.g., CMY Bayer as well as other non-Bayer patterns), other numbers of image sensors, operating on different image format types, and being configured for still and/or moving pictures. For example, the embodiments disclosed herein may be performed on image data captured using a color filter array (CFA) having a Bayer pattern or a different, non-Bayer pattern. Thus, it is to be understood that the embodiments disclosed herein are exemplary but nonlimiting embodiments, and thus, the inventions disclosed herein are not limited to the disclosed exemplary embodiments.

[0053] With continued reference to Figure 1, a camera 10 can include a body or housing 12 configured to support a system 14 configured to detect, process, and optionally store and/or replay video image data. For example, the system 14 can include optics hardware 16, an image sensor 18, an image processing module 20, a compression module 22, and a storage device 24. Optionally, the camera 10 can also include a monitor module 26, a playback module 28, and a display 30.

[0054] Figure 2 illustrates a nonlimiting exemplary embodiment of the camera 10. As shown in Figure 2, the optics hardware 16 can be supported by the housing 12 in a manner that leaves it exposed at its outer surface. In some embodiments, the system 14 is supported within the housing 12. For example, the image sensor 18, image processing module 20, and the compression module 22 can be housed within the housing 12. The storage device 24 can be mounted in the housing 12. Additionally, in some embodiments, the storage device 24 can be mounted to an exterior of the housing 12 and connected to the remaining portions of the

system 14 through any type of known connector or cable. Additionally, the storage device 24 can be connected to the housing 12 with a flexible cable, thus allowing the storage device 24 to be moved somewhat independently from the housing 12. For example, with such a flexible cable connection, the storage device 24 can be worn on a belt of a user, allowing the total weight of the housing 12 to be reduced. Further, in some embodiments, the housing can include one or more storage devices 24 inside and mounted to its exterior. Additionally, the housing 12 can also support the monitor module 26, and playbook module 28. Additionally, in some embodiments, the display 30 can be configured to be mounted to an exterior of the housing 12.

[0055] The optics hardware 16 can be in the form of a lens system having at least one lens configured to focus an incoming image onto the image sensor 18. The optics hardware 16, optionally, can be in the form of a multi-lens system providing variable zoom, aperture, and focus. Additionally, the optics hardware 16 can be in the form of a lens socket supported by the housing 12 and configured to receive a plurality of different types of lens systems for example, but without limitation, the optics hardware 16 include a socket configured to receive various sizes of lens systems including a 50-100 millimeter (F2.8) zoom lens, an 18-50 millimeter (F2.8) zoom lens, a 300 millimeter (F2.8) lens, 15 millimeter (F2.8) lens, 25 millimeter (F1.9) lens, 35 millimeter (F1.9) lens, 50 millimeter (F1.9) lens, 85 millimeter (F1.9) lens, and/or any other lens. As noted above, the optics hardware 16 can be configured such that despite which lens is attached thereto, images can be focused upon a light-sensitive surface of the image sensor 18.

[0056] The image sensor 18 can be any type of video sensing device, including, for example, but without limitation, CCD, CMOS, vertically-stacked CMOS devices such as the Foveon® sensor, or a multi-sensor array using a prism to divide light between the sensors. In some embodiments, the image sensor 18 can include a CMOS device having about 12 million photocells. However, other size sensors can also be used. In some configurations, camera 10 can be configured to record and/or output video (e.g., compressed raw video) at “2k” (e.g., 2048 x 1152 pixels), “4k” (e.g., 4,096 x 2,540 pixels), “4.5k” horizontal resolution, “5k” horizontal resolution (e.g., 5120 x 2700 pixels), “6k” horizontal resolution (e.g., 6144 x 3160), or greater resolutions. In some embodiments, the camera can be configured to record

compressed raw image data having a horizontal resolution of between at least any of the above-recited resolutions. In further embodiments, the resolution is between at least one of the aforementioned values (or some value between the aforementioned values) and about 6.5k, 7k, 8k, 9k, or 10k, or some value therebetween). As used herein, in the terms expressed in the format of xk (such as 2k and 4k noted above), the “x” quantity refers to the approximate horizontal resolution. As such, “4k” resolution corresponds to about 4000 or more horizontal pixels and “2k” corresponds to about 2000 or more pixels. Using currently commercially available hardware, the sensor can be as small as about 0.5 inches (8 mm), but it can be about 1.0 inches, or larger. Additionally, the image sensor 18 can be configured to provide variable resolution by selectively outputting only a predetermined portion of the sensor 18. For example, the sensor 18 and/or the image processing module can be configured to allow a user to identify the resolution of the image data output.

[0057] The camera 10 can also be configured to downsample and subsequently process the output of the sensor 18 to yield video output at 2K, 1080p, 720p, or any other resolution. For example, the image data from the sensor 18 can be “windowed”, thereby reducing the size of the output image and allowing for higher readout speeds. However, other size sensors can also be used. Additionally, the camera 10 can be configured to upsample the output of the sensor 18 to yield video output at higher resolutions.

[0058] With reference to Figure 1 and 3, in some embodiments, the sensor 18 can include a Bayer pattern filter. As such, the sensor 18, by way of its chipset (not shown) outputs data representing magnitudes of red, green, or blue light detected by individual photocells of the image sensor 18. Figure 3 schematically illustrates the Bayer pattern output of the sensor 18. In some embodiments, for example, as shown in Figure 3, the Bayer pattern filter has twice as many green elements as the number of red elements and the number of blue elements. The chipset of the image sensor 18 can be used to read the charge on each element of the image sensor and thus output a stream of values in the well-known RGB format output.

[0059] With continued reference to Figure 4, the image processing module 20 optionally can be configured to format the data stream from the image sensor 18 in any known manner. In some embodiments, the image processing module 20 can be configured to separate the green, red, and blue image data into three or four separate data compilations. For example,

the image processing module 20 can be configured to separate the red data into one data element, the blue data into one blue data element, and the green data into one green data element. For example, with reference to Figure 4, the image processing module 20 can include a red data processing module 32, a blue data image processing module 34, and a first green image data processing module 36.

[0060] As noted above, however, the Bayer pattern data illustrated in Figure 3, has twice as many green pixels as the other two colors. Figure 5 illustrates a data component with the blue and red data removed, leaving only the original green image data.

[0061] In some embodiments, the camera 10 can be configured to delete or omit some of the green image data. For example, in some embodiments, the image processing module 20 can be configured to delete 1/2 of the green image data so that the total amount of green image data is the same as the amounts of blue and red image data. For example, Figure 6 illustrates the remaining data after the image processing module 20 deletes 1/2 of the green image data. In the illustrated embodiment of Figure 6, the rows n-3, n-1, n+1, and n+3 have been deleted. This is merely one example of the pattern of green image data that can be deleted. Other patterns and other amounts of green image data can also be deleted.

[0062] In some alternatives, the camera 10 can be configured to delete 1/2 of the green image data after the red and blue image data has been transformed based on the green image data. This optional technique is described below following the description of the subtraction of green image data values from the other color image data.

[0063] Optionally, the image processing module 20 can be configured to selectively delete green image data. For example, the image processing module 20 can include a deletion analysis module (not shown) configured to selectively determine which green image data to delete. For example, such a deletion module can be configured to determine if deleting a pattern of rows from the green image data would result in aliasing artifacts, such as Moiré lines, or other visually perceptible artifacts. The deletion module can be further configured to choose a pattern of green image data to delete that would present less risk of creating such artifacts. For example, the deletion module can be configured to choose a green image data deletion pattern of alternating vertical columns if it determines that the image captured by the image sensor 18 includes an image feature characterized by a plurality of parallel horizontal

lines. This deletion pattern can reduce or eliminate artifacts, such as Moiré lines, that might have resulted from a deletion pattern of alternating lines of image data parallel to the horizontal lines detected in the image.

[0064] However, this merely one exemplary, non-limiting example of the types of image features and deletion patterns that can be used by the deletion module. The deletion module can also be configured to detect other image features and to use other image data deletion patterns, such as for example, but without limitation, deletion of alternating rows, alternating diagonal lines, or other patterns. Additionally, the deletion module can be configured to delete portions of the other image data, such as the red and blue image data, or other image data depending on the type of sensor used.

[0065] Additionally, the camera 10 can be configured to insert a data field into the image data indicating what image data has been deleted. For example, but without limitation, the camera 10 can be configured to insert a data field into the beginning of any video clip stored into the storage device 24, indicating what data has been deleted in each of the “frames” of the video clip. In some embodiments, the camera can be configured to insert a data field into each frame captured by the sensor 18, indicating what image data has been deleted. For example, in some embodiments, where the image processing module 20 is configured to delete $\frac{1}{2}$ of the green image data in one deletion pattern, the data field can be as small as a single bit data field, indicating whether or not image data has been deleted. Since the image processing module 20 is configured to delete data in only one pattern, a single bit is sufficient to indicate what data has been deleted.

[0066] In some embodiments, as noted above, the image processing module 20 can be configured to selectively delete image data in more than one pattern. Thus, the image data deletion field can be larger, including a sufficient number of values to provide an indication of which of the plurality of different image data deletion patterns was used. This data field can be used by downstream components and or processes to determine to which spatial positions the remaining image data corresponds.

[0067] In some embodiments, the image processing module can be configured to retain all of the raw green image data, e.g., the data shown in Figure 5. In such embodiments, the image processing module can include one or more green image data processing modules.

[0068] As noted above, in known Bayer pattern filters, there are twice as many green elements as the number of red elements and the number of blue elements. In other words, the red elements comprise 25% of the total Bayer pattern array, the blue elements corresponded 25% of the Bayer pattern array and the green elements comprise 50% of the elements of the Bayer pattern array. Thus, in some embodiments, where all of the green image data is retained, the image processing module 20 can include a second green data image processing module 38. As such, the first green data image processing module 36 can process half of the green elements and the second green image data processing module 38 can process the remaining green elements. However, the present inventions can be used in conjunction with other types of patterns, such as for example, but without limitation, CMY and RGBW.

[0069] Figure 7 includes schematic illustrations of the red, blue and two green data components processed by modules 32, 34, 36, and 38 (Figure 4). This can provide further advantages because the size and configuration of each of these modules can be about the same since they are handling about the same amount of data. Additionally, the image processing module 20 can be selectively switched between modes in which it processes all of the green image data (by using both modules 36 and 38) and modes where $\frac{1}{2}$ of the green image data is deleted (in which it utilizes only one of modules 36 and 38). However, other configurations can also be used.

[0070] Additionally, in some embodiments, the image processing module 20 can include other modules and/or can be configured to perform other processes, such as, for example, but without limitation, gamma correction processes, noise filtering processes, etc.

[0071] Additionally, in some embodiments, the image processing module 20 can be configured to subtract a value of a green element from a value of a blue element and/or red element. As such, in some embodiments, when certain colors are detected by the image sensor 18, the corresponding red or blue element can be reduced to zero. For example, in many photographs, there can be large areas of black, white, or gray, or a color shifted from gray toward the red or blue colors. Thus, if the corresponding pixels of the image sensor 18 have sensed an area of gray, the magnitude of the green, red, and blue, would be about equal. Thus, if the green value is subtracted from the red and blue values, the red and blue values will drop to zero or near zero. Thus, in a subsequent compression process, there will be more zeros

generated in pixels that sense a black, white, or gray area and thus the resulting data will be more compressible. Additionally, the subtraction of green from one or both of the other colors can make the resulting image data more compressible for other reasons.

[0072] Such a technique can help achieve a higher effective compression ratio and yet remain visually lossless due to its relationship to the entropy of the original image data. For example, the entropy of an image is related to the amount of randomness in the image. The subtraction of image data of one color, for example, from image data of the other colors can reduce the randomness, and thus reduce the entropy of the image data of those colors, thereby allowing the data to be compressed at higher compression ratios with less loss. Typically, an image is not a collection of random color values. Rather, there is often a certain degree of correlation between surrounding picture elements. Thus, such a subtraction technique can use the correlation of picture elements to achieve better compression. The amount of compression will depend, at least in part, on the entropy of the original information in the image.

[0073] In some embodiments, the magnitudes subtracted from a red or blue pixel can be the magnitude of the value output from a green pixel adjacent to the subject red or blue pixel. Further, in some embodiments, the green magnitude subtracted from the red or blue elements can be derived from an average of the surrounding green elements. Such techniques are described in greater detail below. However, other techniques can also be used.

[0074] Optionally, the image processing module 20 can also be configured to selectively subtract green image data from the other colors. For example, the image processing module 20 can be configured to determine if subtracting green image data from a portion of the image data of either of the other colors would provide better compressibility or not. In this mode, the image processing module 20 can be configured to insert flags into the image data indicating what portions of the image data has been modified (by e.g., green image data subtraction) and which portions have not been so modified. With such flags, a downstream demosaicing/reconstruction component can selectively add green image values back into the image data of the other colors, based on the status of such data flags.

[0075] Optionally, image processing module 20 can also include a further data reduction module (not shown) configured to round values of the red and blue data. For

example, if, after the subtraction of green magnitudes, the red or blue data is near zero (e.g., within one or two on an 8-bit scale ranging from 0-255 or higher magnitudes for a higher resolution system). For example, the sensor 18 can be a 12-bit sensor outputting red, blue, and green data on a scale of 0-4095. Any rounding or filtering of the data performed the rounding module can be adjusted to achieve the desired effect. For example, rounding can be performed to a lesser extent if it is desired to have lossless output and to a greater extent if some loss or lossy output is acceptable. Some rounding can be performed and still result in a visually lossless output. For example, on a 8-bit scale, red or blue data having absolute value of up to 2 or 3 can be rounded to 0 and still provide a visually lossless output. Additionally, on a 12-bit scale, red or blue data having an absolute value of up to 10 to 20 can be rounded to 0 and still provide visually lossless output.

[0076] Additionally, the magnitudes of values that can be rounded to zero, or rounded to other values, and still provide a visually lossless output depends on the configuration of the system, including the optics hardware 16, the image sensor 18, the resolution of the image sensor, the color resolution (bit) of the image sensor 18, the types of filtering, anti-aliasing techniques or other techniques performed by the image processing module 20, the compression techniques performed by the compression module 22, and/or other parameters or characteristics of the camera 10.

[0077] As noted above, in some embodiments, the camera 10 can be configured to delete $\frac{1}{2}$ of the green image data after the red and blue image data has been transformed based on the green image data. For example, but without limitation, the processor module 20 can be configured to delete $\frac{1}{2}$ of the green image data after the average of the magnitudes of the surrounding green data values have been subtracted from the red and blue data values. This reduction in the green data can reduce throughput requirements on the associated hardware. Additionally, the remaining green image data can be used to reconstruct the red and blue image data, described in greater detail below with reference to Figures 14 and 16.

[0078] As noted above, the camera 10 can also include a compression module 22. The compression module 22 can be in the form of a separate chip or it can be implemented with software and another processor. For example, the compression module 22 can be in the form of a commercially available compression chip that performs a compression technique in

accordance with the JPEG 2000 standard, or other compression techniques. In some embodiments, the image processing module 20 and/or the compression module 22 are implemented in a field-programmable gate array (FPGA), an application-specific integrated circuit (ASIC), combinations of the same or the like.

[0079] The compression module 22 can be configured to perform any type of compression process on the data from the image processing module 20. In some embodiments, the compression module 22 performs a compression technique that takes advantage of the techniques performed by the image processing module 20. For example, as noted above, the image processing module 20 can be configured to reduce the magnitude of the values of the red and blue data by subtracting the magnitudes of green image data, thereby resulting in a greater number of zero values, as well as other effects. Additionally, the image processing module 20 can perform a manipulation of raw data that uses the entropy of the image data. Thus, the compression technique performed by the compression module 22 can be of a type that benefits from the presence of larger strings of zeros to reduce the size of the compressed data output therefrom.

[0080] Further, the compression module 22 can be configured to compress the image data from the image processing module 20 to result in a visually lossless output. For example, firstly, the compression module can be configured to apply any known compression technique, such as, but without limitation, JPEG 2000, MotionJPEG, any DCT based codec, any codec designed for compressing RGB image data, H.264, MPEG4, Huffman, or other techniques.

[0081] Depending on the type of compression technique used, the various parameters of the compression technique can be set to provide a visually lossless output. For example, many of the compression techniques noted above can be adjusted to different compression rates, wherein when decompressed, the resulting image is better quality for lower compression rates and lower quality for higher compression rates. Thus, the compression module can be configured to compress the image data in a way that provides a visually lossless output, or can be configured to allow a user to adjust various parameters to obtain a visually lossless output. For example, the compression module 22 can be configured to compress the image data at a compression ratio of about 6:1, 7:1, 8:1 or greater. In some

embodiments, the compression module 22 can be configured to compress the image data to a ratio of 12:1 or higher.

[0082] Additionally, the compression module 22 can be configured to allow a user to adjust the compression ratio achieved by the compression module 22. For example, the camera 10 can include a user interface that allows a user to input commands that cause the compression module 22 to change the compression ratio. Thus, in some embodiments, the camera 10 can provide for variable compression.

[0083] As used herein, the term “visually lossless” is intended to include output that, when compared side by side with original (never compressed) image data on the same display device, one of ordinary skill in the art would not be able to determine which image is the original with a reasonable degree of accuracy, based only on a visual inspection of the images.

[0084] With continued reference to Figure 1, the camera 10 can also include a storage device 24. The storage device can be in the form of any type of digital storage, such as, for example, but without limitation, hard disks, flash memory, or any other type of memory device. In some embodiments, the size of the storage device 24 can be sufficiently large to store image data from the compression module 22 corresponding to at least about 30 minutes of video at 12 mega pixel resolution, 12-bit color resolution, and at 60 frames per second. However, the storage device 24 can have any size.

[0085] In some embodiments, the storage device 24 can be mounted on an exterior of the housing 12. Further, in some embodiments, the storage device 24 can be connected to the other components of the system 14 through standard communication ports, including, for example, but without limitation, IEEE 1394, USB 2.0, IDE, SATA, etc. Further, in some embodiments, the storage device 24 can comprise a plurality of hard drives operating under a RAID protocol. However, any type of storage device can be used.

[0086] With continued reference to Figure 1, as noted above, in some embodiments, the system can include a monitor module 26 and a display device 30 configured to allow a user to view video images captured by the image sensor 18 during operation. In some embodiments, the image processing module 20 can include a subsampling system configured to output reduced resolution image data to the monitor module 26. For example,

such a subsampling system can be configured to output video image data to support 2K, 1080p, 720p, or any other resolution. In some embodiments, filters used for demosaicing can be adapted to also perform downsampling filtering, such that downsampling and filtering can be performed at the same time. The monitor module 26 can be configured to perform any type of demosaicing process to the data from the image processing module 20. Thereafter, the monitor module 26 can output a demosaiced image data to the display 30.

[0087] The display 30 can be any type of monitoring device. For example, but without limitation, the display 30 can be a four-inch LCD panel supported by the housing 12. For example, in some embodiments, the display 30 can be connected to an infinitely adjustable mount configured to allow the display 30 to be adjusted to any position relative to the housing 12 so that a user can view the display 30 at any angle relative to the housing 12. In some embodiments, the display 30 can be connected to the monitor module through any type of video cables such as, for example, an RGB or YCC format video cable.

[0088] Optionally, the playback module 28 can be configured to receive data from the storage device 24, decompressed and demosaic the image data and then output the image data to the display 30. In some embodiments, the monitor module 26 and the playback module 28 can be connected to the display through an intermediary display controller (not shown). As such, the display 30 can be connected with a single connector to the display controller. The display controller can be configured to transfer data from either the monitor module 26 or the playback module 28 to the display 30.

[0089] Figure 8 includes a flowchart 50 illustrating the processing of image data by the camera 10. In some embodiments, the flowchart 50 can represent a control routine stored in a memory device, such as the storage device 24, or another storage device (not shown) within the camera 10. Additionally, a central processing unit (CPU) (not shown) can be configured to execute the control routine. The below description of the methods corresponding to the flow chart 50 are described in the context of the processing of a single frame of video image data. Thus, the techniques can be applied to the processing of a single still image. These processes can also be applied to the processing of continuous video, e.g., frame rates of greater than 12, as well as frame rates of 20, 23.98, 24, 25, 29.97, 30, 47.96,

48, 50, 59.94, 60, 120, 250, frames per second, or other frame rates between these frame rates or greater.

[0090] With continued reference to Figure 8, control routine can begin at operation block 52. In the operation block 52, the camera 10 can obtain sensor data. For example, with reference to Figure 1, the image sensor 18, which can include a Bayer Sensor and chipset, can output image data.

[0091] For example, but without limitation, with reference to Figure 3, the image sensor can comprise a CMOS device having a Bayer pattern filter on its light receiving surface. Thus, the focused image from the optics hardware 16 is focused on the Bayer pattern filter on the CMOS device of the image sensor 18. Figure 3 illustrates an example of the Bayer pattern created by the arrangement of Bayer pattern filter on the CMOS device.

[0092] In Figure 3, column m is the fourth column from the left edge of the Bayer pattern and row n is the fourth row from the top of the pattern. The remaining columns and rows are labeled relative to column m and row n. However, this layout is merely chosen arbitrarily for purposes of illustration, and does not limit any of the embodiments or inventions disclosed herein.

[0093] As noted above, known Bayer pattern filters often include twice as many green elements as blue and red elements. In the pattern of figure 5, blue elements only appear in rows n-3, n-1, n+1, and n+3. Red elements only appear in rows n-2, n, n+2, and n+4. However, green elements appear in all rows and columns, interspersed with the red and blue elements.

[0094] Thus, in the operation block 52, the red, blue, and green image data output from the image sensor 18 can be received by the image processing module 20 and organized into separate color data components, such as those illustrated in Figure 7. As shown in Figure 7, and as described above with reference to Figure 4, the image processing module 20 can separate the red, blue, and green image data into four separate components. Figure 7 illustrates two green components (Green 1 and Green 2), a blue component, and a red component. However, this is merely one exemplary way of processing image data from the image sensor 18. Additionally, as noted above, the image processing module 20, optionally, can arbitrarily or selectively delete $\frac{1}{2}$ of the green image data.

[0095] After the operation block 52, the flowchart 50 can move on to operation block 54. In the operation block 54, the image data can be further processed. For example, optionally, any one or all of the resulting data (e.g., green 1, green 2, the blue image data from Figure 9, and the red image data from Figure 10) can be further processed.

[0096] For example, the image data can be pre-emphasized or processed in other ways. In some embodiments, the image data can be processed to be more (mathematically) non-linear. Some compression algorithms benefit from performing such a linearization on the picture elements prior to compression. However, other techniques can also be used. For example, the image data can be processed with a linear curve, which provides essentially no emphasis.

[0097] For instance, the image data may represent linear light sensor data, and the pre-emphasis curve can be designed to preserve detail in darker regions upon application of the compression algorithm. For instance, the pre-emphasis function can be designed emphasize darker image data values in comparison to brighter image data values, e.g., by applying a log curve or other appropriate function that weights darker image data values higher than brighter image data values. In some cases, the pre-emphasis curve may cause some reduction in precision in highlights or other relatively brighter image regions while preserving detail in shadows or other darker image regions. In some embodiments, the operation block 54 can process the image data using curve defined by the function $y=x^{0.5}$. In some embodiments, this curve can be used where the image data was, for example but without limitation, floating point data in the normalized 0-1 range. In other embodiments, for example, where the image data is 12-bit data, the image can be processed with the curve $y=(x/4095)^{0.5}$. Additionally, the image data can be processed with other curves, such as $y=(x+c)^g$ where $0.01 < g < 1$ and c is an offset, which can be 0 in some embodiments. Additionally, log curves can also be used. For example, curves in the form $y=A*\log(B*x+C)$ where A , B , and C are constants chosen to provide the desired results. The pre-emphasis curve according to certain embodiments does not reduce the bit depth of the image data. Additionally, the above curves and processes can be modified to provide more linear areas in the vicinity of black, similar to those techniques utilized in the well-known Rec709 gamma curve. In applying these processes to the image data, the same processes can be applied to all

of the image data, or different processes can be applied to the different colors of image data. However, these are merely exemplary curves that can be used to process the image data, or curves or transforms can also be used. Additionally, these processing techniques can be applied using mathematical functions such as those noted above, or with Look Up Tables (LUTs). Additionally, different processes, techniques, or transforms can be used for different types of image data, different ISO settings used during recording of the image data, temperature (which can affect noise levels), etc.

[0098] After the operation block 54, the flowchart 50 can move to an operation block 56. In the operation block 56, the red and blue picture elements can be transformed. For example, as noted above, green image data can be subtracted from each of the blue and red image data components. In some embodiments, a red or blue image data value can be transformed by subtracting a green image data value of at least one of the green picture elements adjacent to the red or blue picture element. In some embodiments, an average value of the data values of a plurality of adjacent green picture elements can be subtracted from the red or blue image data value. For example, but without limitation, average values of 2, 3, 4, or more green image data values can be calculated and subtracted from red or blue picture elements in the vicinity of the green picture elements.

[0099] For example, but without limitation, with reference to Figure 3, the raw output for the red element $R_{m-2,n-2}$ (also referred to as the “target” pixel or element) is surrounded by four green picture elements $G_{m-2,n-3}$, $G_{m-1,n-2}$, $G_{m-3,n-2}$, and $G_{m-2,n-1}$. Thus, the red element $R_{m-2,n-2}$ can be transformed by subtracting the average of the values of the green elements surrounding the target element as follows:

$$(1) \quad R_{m,n} = R_{m,n} - (G_{m,n-1} + G_{m+1,n} + G_{m,n+1} + G_{m-1,n})/4$$

[0100] Similarly, the blue elements can be transformed in a similar manner by subtracting the average of the green elements surrounding the blue target element as follows:

$$(2) \quad B_{m+1,n+1} = B_{m+1,n+1} - (G_{m+1,n} + G_{m+2,n+1} + G_{m+1,n+2} + G_{m,n+1})/4$$

[0101] Figure 9 illustrates a resulting blue data component where the original blue raw data $B_{m-1,n-1}$ (e.g., the target pixel) is transformed, the new value labeled as $B'_{m-1,n-1}$ (only one value in the component is filled in and the same technique can be used for all the blue elements). Similarly, Figure 10 illustrates the red data component having been transformed in

which the transformed red element $R_{m-2,n-2}$ (e.g., the target pixel) is identified as $R'_{m-2,n-2}$. The mathematical process performed on the data are entirely reversible such that all of the original values can be obtained by reversing those processes.

[0102] With continued reference to Figure 8, after the operation block 56, the flowchart 50 can move on to an operation block 58. In the operation block 58, the resulting data, which is raw or can be substantially raw, can be further compressed to using any known compression algorithm and which is according to various implementations a lossy compression algorithm (e.g., a compression algorithm capable of achieving compression ratios of at least 3, 4, 5, 6, 7, 8, 9, 10, 11, or 12 to 1, or higher). For example, the compression module 22 (Figure 1) can be configured to perform such a compression algorithm. After compression, the compressed raw data can be stored in the storage device 24 (Figure 1). According to certain embodiments, the term “raw” as used herein in conjunction with compressed image data remains mosaiced (e.g., according to a Bayer pattern or is mosaiced according to some other color filter array) and has therefore not undergone a demosaicing operation prior to compression. According to various implementations, the term “raw” can indicate that the image data has not undergone any combination of one or more of the following operations prior to compression: demosaicing (sometimes alternatively referred to as “color interpolation”), color correction (sometimes alternatively referred to as “color compensation” or “color matrix processing”), tonal processing (e.g., application of tonal curves, contrast enhancement), gamma processing (sometimes alternatively referred to as “gamma correction”) prior to compression.

[0103] In various embodiments, the flowchart 50 of Figure 8 may further include one or more denoising and/or noise reduction operation blocks. For example, a denoising operation block may be included after the transforming of operation block 56. For example, the denoising step can include noise removal techniques, such as spatial denoising where a single image frame is used for noise suppression in a pixel or picture element. Temporal denoising methods that use multiple image frames for noise correction can also be employed, including motion adaptive, semi-motion adaptive, or motion compensative methods. Additionally, other noise removal methods can be used to remove noise from images or a video signal. Various example noise removal techniques are described in detail in U.S.

Provisional Application 61/764,821 (the “821 Application”) and U.S. Patent No. 8,237,830 (the “830 patent”), which are incorporated by reference herein in their entirety.

[0104] In some embodiments, a denoising stage may occur before compression in operation block 58. Removing noise from data prior to compression can be advantageous because it can greatly improve the effectiveness of the compression process. In some embodiments, noise removal can be done as part of the compression process in operation block 58.

[0105] In various embodiments, a denoising stage can occur at numerous points in the image data transformation process. For example, denoising can be applied after operation block 52 to raw image data from an image sensor prior to transformation; or to Bayer pattern (or other mosaiced) data after the transformation in operation block 56. In some embodiments, denoising can be applied before or after the pre-emphasis of data that occurs in operation block 54. Of note, denoising data before pre-emphasis can be advantageous because denoising can operate more effectively on perceptually linear data. In addition, in exemplary embodiments, green image data can be denoised before operation block 56 to minimize noise during the transformation process of red and blue picture elements in operation block 56.

[0106] Figure 8A illustrates a modification of the flowchart 50, identified by the reference numeral 50'. Some of the steps described above with reference to the flowchart 50 can be similar or the same as some of the corresponding steps of the flowchart 50' and thus are identified with the same reference numerals.

[0107] As shown in Figure 8A, the flowchart 50', in some embodiments, can optionally omit operation block 54. In some embodiments, the flowchart 50' can also include an operation block 57 in which a look up table can be applied to the image data. For example, an optional look-up table, represented by the curve of Figure 11, can be used to enhance further compression. In some embodiments, the look-up table of Figure 11 is only used for the green picture elements. In other embodiments, the look-up table can also be used for red and blue picture elements. The same look-up table may be used for the three different colors, or each color may have its own look-up table. Additionally, processes other than that represented by the curve of Figure 11 can also be applied.

[0108] Additionally, as described above with respect to Figure 8, an additional denoising operation may be included in the flowchart 50' of Figure 8A. Examples of various denoising and noise reduction techniques may be found in the '821 Application and the '830 patent incorporated by reference herein in their entirety.

[0109] By processing the image data in the manner described above with reference to Figures 8 and 8A, it has been discovered that the image data from the image sensor 18 can be compressed into compressed raw image data by a compression ratio of 6 to 1 or greater and remain visually lossless. Additionally, although the image data has been transformed (e.g., by the subtraction of green image data), the transformation is reversible. Moreover, the compressed image data according to certain implementations is still raw. For example, the compressed raw data can be decompressed and gamma processed, color corrected, tonally processed and/or demosaiced using any process the user desires.

[0110] For example, with reference to Figure 12, the data stored in the storage device 24 can be decompressed and demosaiced. Optionally, the camera 10 can be configured to perform the method illustrated by flowchart 60. For example, but without limitation, the playback module 28 can be configured to perform the method illustrated by flowchart 60. However, a user can also transfer the data from the storage device 24 into a separate workstation and apply any or all of the steps and/or operations of the flowchart 60.

[0111] With continued reference to Figure 12, the flowchart 60 can begin with the operation block 62, in which the data from the storage device 24 is decompressed. For example, the decompression of the data in operation block 62 can be the reverse of the compression algorithm performed in operational block 58 (Figure 8). After the operation block 62, the flowchart 60 can move on to an operation block 64.

[0112] In the operation block 64, a process performed in operation block 56 (Figure 8) can be reversed. For example, the inverse of the curve of Figure 11 or the inverse of any of the other functions described above with reference to operation block 56 of Figures 8 and 8A, can be applied to the image data. After the operation block 64, the flowchart 60 can move on to a step 66.

[0113] In the operation block 66, the green picture elements can be demosaiced. For example, as noted above, all the values from the data components Green 1 and/or Green 2

(Figure 7) can be stored in the storage device 24. For example, with reference to Figure 5, the green image data from the data components Green 1, Green 2 can be arranged according to the original Bayer pattern applied by the image sensor 18. The green data can then be further demosaiced by any known technique, such as, for example, linear interpolation, bilinear, etc.

[0114] Figure 13 illustrates an exemplary layout of green image data demosaiced from all of the raw green image data. The green image elements identified with the letter G_x represent original raw (decompressed) image data and the elements identified with “ DG_x ” represent elements that were derived from the original data through the demosaic process. This nomenclature is used with regard to the below descriptions of the demosaicing process for the other colors. Figure 14 illustrates an exemplary image data layout for green image data demosaiced from $\frac{1}{2}$ of the original green image data.

[0115] With continued reference to Figure 12, the flowchart 60 can, after the operation block 66, move on to an operation block 68. In the operation block 68, the demosaiced green image data can be further processed. For example, but without limitation, noise reduction techniques can be applied to the green image data. As described above with respect to Figure 8, examples of various denoising and noise reduction techniques may be found in the ‘821 Application and the ‘830 patent incorporated by reference herein in their entirety. However, any other image processing technique, such as anti-aliasing techniques, can also be applied to the green image data. After the operation block 68, the flowchart 60 can move on to an operation block 70.

[0116] In the operation block 70, the red and blue image data can be demosaiced. For example, firstly, the blue image data of Figure 9 can be rearranged according to the original Bayer pattern (Figure 15). The surrounding elements, as shown in Figure 16, can be demosaiced from the existing blue image data using any known demosaicing technique, including linear interpolation, bilinear, etc. As a result of demosaicing step, there will be blue image data for every pixel as shown in Figure 16. However, this blue image data was demosaiced based on the modified blue image data of Figure 9, i.e., blue image data values from which green image data values were subtracted.

[0117] The operation block 70 can also include a demosaicing process of the red image data. For example, the red image data from Figure 10 can be rearranged according to

the original Bayer pattern and further demosaiced by any known demosaicing process such as linear interpolation, bilinear, etc.

[0118] After the operation block 70, the flowchart can move on to an operation block 72. In the operation block 72, the demosaiced red and blue image data can be reconstructed from the demosaiced green image data.

[0119] In some embodiments, each of the red and blue image data elements can be reconstructed by adding in the green value from co-sited green image element (the green image element in the same column “m” and row “n” position). For example, after demosaicing, the blue image data includes a blue element value $DB_{m-2,n-2}$. Because the original Bayer pattern of Figure 3 did not include a blue element at this position, this blue value $DB_{m-2,n-2}$ was derived through the demosaicing process noted above, based on, for example, blue values from any one of the elements $B_{m-3,n-3}$, $B_{m-1,n-3}$, $B_{m-3,n-1}$, and $B_{m-1,n-1}$ or by any other technique or other blue image elements. As noted above, these values were modified in operation block 54 (Figure 8) and thus do not correspond to the original blue image data detected by the image sensor 18. Rather, an average green value had been subtracted from each of these values. Thus, the resulting blue image data $DB_{m-2,n-2}$ also represents blue data from which green image data has been subtracted. Thus, in one embodiment, the demosaiced green image data for element $DG_{m-2,n-2}$ can be added to the blue image value $DB_{m-2,n-2}$ thereby resulting in a reconstructed blue image data value.

[0120] In some embodiments, optionally, the blue and/or red image data can first be reconstructed before demosaicing. For example, the transformed blue image data $B'_{m-1,n-1}$ can be first reconstructed by adding the average value of the surrounding green elements. This would result in obtaining or recalculating the original blue image data $B_{m-1,n-1}$. This process can be performed on all of the blue image data. Subsequently, the blue image data can be further demosaiced by any known demosaicing technique. The red image data can also be processed in the same or similar manners.

[0121] Figure 12A illustrates a modification of the flowchart 60, identified by the reference numeral 60'. Some of the steps described above with reference to the flowchart 60 can be similar or the same as some of the corresponding steps of the flowchart 60' and thus are identified with the same reference numerals.

[0122] As shown in Figure 12A, the flow chart 60' can include the operation block 68' following operation block 62. In operation block 68', a noise reduction technique can be performed on the image data. For example, but without limitation, noise reduction techniques can be applied to the green image data. As described above with respect to Figure 8, examples of various denoising and noise reduction techniques may be found in the '821 Application and the '830 patent incorporated by reference herein in their entirety. However, any other image processing technique, such as anti-aliasing techniques, can also be applied to the green image data. After operation block 68', the flow chart can move on to operation block 70'

[0123] In operation block 70', the image data can be demosaiced. In the description set forth above with reference to operation blocks 66 and 70, the green, red, and blue image data can be demosaiced in two steps. However, in the present flow chart 60', the demosaicing of all three colors of image data is represented in a single step, although the same demosaicing techniques described above can be used for this demosaicing process. After the operation block 70', the flow chart can move on to operation block 72, in which the red and blue image data can be reconstructed, and operation block 64 in which an inverse look-up table can be applied.

[0124] After the image data has been decompressed and processed according to either of the flow charts 70 or 70', or any other suitable process, the image data can be further processed as demosaiced image data.

[0125] By demosaicing the green image data before reconstructing the red and blue image data, certain further advantages can be achieved. For example, as noted above, the human eye is more sensitive to green light. Demosaicing and processing the green image data optimize the green image values, to which the human eye is more sensitive. Thus, the subsequent reconstruction of the red and blue image data will be affected by the processing of the green image data.

[0126] Additionally, Bayer patterns have twice as many green elements as red and blue elements. Thus, in embodiments where all of the green data is retained, there is twice as much image data for the green elements as compared to either the red or blue image data elements. Thus, the demosaicing techniques, filters, and other image processing techniques result in a better demosaiced, sharpened, or otherwise filtered image. Using these demosaiced

values to reconstruct and demosaic the red and blue image data transfers the benefits associated with the higher resolution of the original green data to the process, reconstruction, and demosaicing of the red and blue elements. As such, the resulting image is further enhanced.

[0127] Further, as described above, green channel data may be subtracted from each of the blue and red channels to improve compressibility of the image data with little or no visual loss. According to various embodiments, this advantageous improved compressibility is possible, at least in part, because the color and/or intensity of the red and blue channels are correlated with the color and/or intensity of green channels. Accordingly, subtracting green channel data from red and/or blue channel data may de-correlate a portion of the color and/or intensity data, improving compressibility.

Green Average Subtraction

[0128] Referring again to Figures 1 and 4, the image processing module 20 can be configured to modify image data based on green image data, such as by modifying Green 2 image data based on Green 1 image data or vice versa, and/or modifying Red and Blue image data based on Green image data. For instance, the image processing module 20 could be configured to compute an average green value from a neighborhood, or “kernel,” of Green pixels. For example, in various embodiments the image processing module 20 may determine multiple Green pixels located near, or adjacent to, a current pixel of interest (also referred to as a target pixel). These determined Green pixels may be referred to as the kernel of Green pixels. Green pixels adjacent to a target pixel (for example, the kernel associated with the target pixel) may include Green pixels located above or below, beside, and/or diagonal to, the target pixel. For example, the Green pixels adjacent to the target pixel may include some or all of the Green pixels that are physically nearest to the target pixel.

[0129] In some cases, the calculated green value is spatially co-located or spatially correlated with the target pixel. For instance, values for at least two pixels opposing one another with respect to the target pixel may be averaged or combined using some other appropriate type of algorithm to generate the calculated green value. For instance, at least two pixels may include pixels diagonally opposing one another with respect to the target pixel,

pixels above and below the target pixel, pixels to the left and right of the target pixel, or a combination thereof.

[0130] In various implementations, Green pixels located a further distance from the target pixel may be used to generate the calculated green value (e.g., calculate an average green value). The calculated green value may be used to perform GAS (Green Average Subtraction), in which the average green value calculated with respect to a target pixel may be subtracted from the target pixel. For example, in GAS, average green values may be subtracted from pixels in the Red/Blue data path and/or one of the Green data paths.

[0131] For example, the image processing module 20 may compute a 4-pixel average of a kernel of pixels (e.g., defect corrected and noise reduced pixels) which may include an average Green value relative to any particular pixel (e.g., a target pixel). Neighboring Green pixels (or a kernel of Green pixels) to be averaged may be selected based on whether an even row is being processed or an odd row is being processed, as well as whether a Red, Blue, or Green pixel is a target pixel. For example, referring again to Figure 3, when the target pixel is the Red pixel $R_{m,n}$, the four neighboring pixels may include $G_{m,n-1}$, $G_{m+1,n}$, $G_{m,n+1}$, and $G_{m-1,n}$. Similarly, when the target pixel is Blue pixel $B_{m-1,n-1}$, the four neighboring pixels may include $G_{m-1,n-2}$, $G_{m,n-1}$, $G_{m-1,n}$, and $G_{m-2,n-1}$. In each of these examples, when the target pixel is a Red or Blue pixel, the four neighboring pixels may include Green pixels immediately adjacent to the target pixel, for example, the pixels above and below and immediately on either side of the Red/Blue pixel.

[0132] Referring to Figure 17, an example of neighboring, or kernel, pixel selection is shown with respect to a Green target pixel, according to various embodiments. As shown, and as described above, each alternating row of image data may include Green1 channel or Green2 channel image data/pixels. As mentioned above, in various embodiments it may be advantageous to subtract or otherwise modify Green2 data based on Green1 data (or vice versa, depending on the embodiment), for example, to perform GAS on Green 2 data. For instance, in some embodiments an average of a kernel of Green1 data may be subtracted from Green2 data (or vice versa), as is described further below. As one example, the image processing module 20 can be configured to compute a 4-pixel average of defect corrected and noise reduced pixels of Green1 data for a given pixel of Green2 data. In various embodiments,

depending on a sensor configuration, average green values may be calculated based on green data on even rows or green data on odd rows. In the case of Bayer pattern image data or other appropriate mosaic image data, the 4 neighboring pixels can be selected for one of the two green channels. In one embodiment, a register can select whether Greens on the Red line (e.g., even line) will be used as a reference or if Green on a Blue row (e.g., odd line) will be used as a reference. By subtracting the kernel of Green 1 values from the current Green 2 value, and encoding the residual, the Green 1 channel is effectively used as a predictor of the Green 2 channel.

[0133] In an embodiment, when the target pixel is Green 2 pixel $G_{m-1,n}$ (labeled 180), the four neighboring Green 1 pixels may include $G_{m-2,n-1}$, $G_{m,n-1}$, $G_{m,n+1}$, and $G_{m-2,n+1}$ (labeled 181, 182, 183, and 184 respectively). In this example, it may be seen that, for Bayer pattern image data, when the target pixel is a Green pixel, the four closest neighboring pixels may be used as a kernel and may include Green pixels of the other channel (for example, Green 1 channel vs. Green 2 channel) immediately diagonally adjacent (for example, immediately adjacent, diagonally adjacent, spatially adjacent) to the target pixel, for example, the pixels diagonally opposite the Green target pixel. In one embodiment, only two of the diagonally adjacent Green pixels are used as a kernel (e.g., pixel 181 and pixel 183, pixel 184 and pixel 182). In both cases (i.e., where two diagonally opposing adjacent pixels are used or where all four diagonally adjacent pixels are used), there is some degree of spatial colocation and spatial correlation between the pixels used in the calculation and the target pixel, resulting in better results, e.g., results suitable for cinema applications. This can reduce or eliminate the occurrence of edge exaggeration on color boundaries or other undesirable artifacts, which may occur where only a single Green pixel is used in the calculation, or where only pixels on one side of the Green pixel are employed in the calculation, such as an embodiment where only pixel 181 and pixel 184 are used, or only pixels 182 and 183 are employed. In some alternative embodiments, only a single Green pixel is used in the calculation, or only pixels from one side of the target pixel are used.

[0134] In various embodiments, and as mentioned above, an average green value (or green value calculated according to some other appropriate algorithm) may be computed based on a kernel of Green pixels located a further distance from the target pixel. Referring

again to Figure 17, for the target Green 2 pixel 180 and as described above, selecting a kernel of Green 1 pixels located a first distance away from Green 2 pixel 180 may include all Green 1 pixels contained within a first conceptual square box surrounding Green 2 pixel 180 and having an edge length of three pixels. This first conceptual square box includes Green 1 pixels $G_{m-2,n-1}$, $G_{m,n-1}$, $G_{m,n+1}$, and $G_{m-2,n+1}$ (labeled 181, 182, 183, and 184 respectively). Similarly, selecting a kernel of Green 1 pixels located a second, further distance away from Green 2 pixel 180 may include all Green 1 pixels contained within a second, larger conceptual square box surrounding Green 2 pixel 180 having an edge length of seven pixels. This second conceptual square box includes, in addition to the Green 1 pixels in the first conceptual box, Green 1 pixels $G_{m-2,n-3}$, $G_{m,n-3}$, $G_{m+2,n-3}$, $G_{m+2,n-1}$, $G_{m+2,n+1}$, $G_{m+2,n+3}$, $G_{m,n+3}$, $G_{m-2,n+3}$, and four additional Green 1 pixels not shown (but that would be present in a column $m-4$ if shown). This second conceptual box is the next largest square box surrounding the target Green 2 pixel that includes additional Green 1 pixels. In various embodiments, similar to the description above, any combination of Green 1 pixels in the second conceptual box surrounding the target Green 2 pixel may be selected as a kernel. For example, in an embodiment Green 1 pixels located along one or both diagonals from the target pixel may be used as a kernel. As described above, an average green value of the selected kernel of Green 1 pixels neighboring the target Green 2 pixel (or vice versa) may be computed. This value may be subtracted from the value of the target Green 2 pixel to determine a residual, and the residual may be encoded. Accordingly, the Green 1 channel may effectively be used as a predictor of the Green 2 channel.

[0135] Similarly, in various embodiments an average green value with respect to a Red and/or Blue target pixel may be computed based on neighboring Green pixels located a further distance from the target pixel (rather than, or in addition to, the Green pixels immediately adjacent to the target pixel). For example, referring again to Figure 3, when the target pixel is the Red pixel $R_{m,n}$, an average green value may be computed based on, for example, any combination of Green pixels $G_{m+1,n-2}$, $G_{m+2,n-1}$, $G_{m+2,n+1}$, $G_{m+1,n+2}$, $G_{m-1,n+2}$, $G_{m-2,n+1}$, $G_{m-2,n-1}$, and/or $G_{m-1,n-2}$, either alone or in addition to the Green pixels mentioned above. In some cases, additional Green pixels further from the target pixel may be also be used (e.g., $G_{m+3,n}$, $G_{m-3,n}$, $G_{m,n-3}$, $G_{m,n+3}$). Similarly, when the target pixel is the Blue pixel $B_{m-1,n-1}$, an

average green value may be computed based on, for example, any combination of Green pixels $G_{m,n-3}$, $G_{m+1,n-2}$, $G_{m+1,n}$, $G_{m,n+1}$, $G_{m-2,n+1}$, $G_{m-3,n}$, $G_{m-3,n-2}$, and/or $G_{m-2,n-3}$, either alone or in addition to the Green pixels mentioned above. In some cases, additional Green pixels further from the target pixel may be also be used.

[0136] In various embodiments, once neighboring Green pixels are determined for any particular target pixel, an average green value may be determined for that target pixel as described above with referenced to Figures 9 and 10 (among others). For example, an average value of the neighboring pixels may be computed and then subtracted from the value of the target pixel. The process of determining an average green value for neighboring pixels and subtracting that average value from a target pixel may be referred to as Green Average Subtraction (GAS).

[0137] As mentioned above, in various embodiments, green data modification (e.g., GAS) may be performed on both Red/Blue data and on Green2 (or Green 1) data. Figure 18 shows a flowchart 170 illustrating an image data transformation technique that may be used with the system illustrated in Figure 1, according to various embodiments. Flowchart 170 may represent a control routine stored in a memory device, such as the storage device 24, or another storage device within the camera 10. Additionally, a central processing unit (CPU) may be configured to execute the control routine. The flowchart 170 may include more or fewer blocks, and/or the blocks may be arranged in a different order than shown in Figure 18. Certain aspects of the flowchart 170 may be similar to the flowcharts 50 and 50' of Figures 8 and 8A described above. Accordingly, certain details regarding flowchart 170 may be found above in the description above with respect to Figures 8 and 8A, where applicable. For instance, while not shown in Figure 18, the image processor 20 may pre-emphasize the data in the manner described above. The pre-emphasis occurs before the transformation of the red, blue, and/or Green 2 picture elements at block 176 and/or the determination of the green average at block 174 in some embodiments. In some other implementations, the pre-emphasis occurs after the operations at blocks 174 and 176, but before application of the compression algorithm at block 178.

[0138] Referring to Figure 18, at block 172 sensor data may be obtained by the camera 10. At block 174, green values for use in green data modification (e.g., average green

values) may be determined and/or computed for the Red, Blue, and/or Green2 pixels as described above. The calculated green values may be computed based on Green1 data and/or Green1 and Green2 data. For example, in an embodiment, GAS with respect to the Red/Blue pixels may be based on both Green1 and Green2 pixels, as described above. Further, GAS with respect to Green2 pixels may be based on Green1 pixels. Alternatively, in an embodiment, GAS with respect to Red/Blue pixels may be based on a single green channel, for example, Green1. In various embodiments, green channel data may be denoised and/or demosaiced before and or after GAS, as described herein.

[0139] At block 176, Red, Blue, and/or Green2 pixels may be transformed as described above. Specifically, in an embodiment respective computed average green values may be subtracted from Red, Blue, and/or Green2 pixel values. In various embodiments Red/Blue or Green2 pixels may be transformed first. For example, in an embodiment Red/Blue pixels are first transformed via GAS based on Green1 and Green2 pixel values, according to any of the methods described above. Then Green2 pixel values may be transformed via GAS based on Green1 pixel values. In another embodiment, Green1 pixel values may be used to transform Red/Blue and Green2 pixel values in any order and/or simultaneously. In an embodiment, Green1 pixel values, or any combination of Green1 and Green2 pixel values (for example, demosaiced green pixel values) may be used to transform Red/Blue pixels. At block 178, Red, Blue, and/or Green channels of data, GAS having been implemented, may be compressed, as described above. Although the image data has been transformed (e.g., by the subtraction of green image data), the transformation is reversible. Moreover, the compressed image data according to certain embodiments is compressed raw image data. For example, the compressed raw data is mosaiced. Moreover, in various implementations, the compressed raw data can be decompressed and then gamma processed, color corrected, tonally processed and/or demosaiced using any process the user desires.

[0140] In an embodiment, GAS may be performed with respect to Green1 data/pixels, rather than with respect to Green2 data/pixels (as described above). In an embodiment, the camera 10 may support GAS performed with respect to either Green1 data and/or Green2 data. In various embodiments, other blocks may be included in flowchart 170. For example, as indicated, flowchart 170 may include a data block in which the image data is

pre-emphasized (for example, similar to block 54 of Figure 8), and/or in which a look up table is applied (for example, similar to block 57 of Figure 8A), among implementing other functions.

[0141] As described above, GAS with respect to a green channel, in addition to Red/Blue channels, may further improve compressibility of the image data with little or no visual loss. In various embodiments, this further improved compressibility is advantageously possible, at least in part, because the first green channel can be used to predict a second green channel and the first and second green channels may be spatially correlated with one another. Accordingly, in an embodiment, subtracting the first green channel data from the second green channel data may at least partially spatially de-correlate the green image data (further reducing entropy and improving compressibility) and the difference, or residual, may be encoded.

GAS at Bayer Borders

[0142] In various embodiments, GAS may be performed for pixels that lie at various edges of mosaiced image data, such as image data that is mosaiced according to a Bayer pattern color filter array. Figure 19 shows an example of determining neighboring pixels for a green pixel at an edge of the Bayer pattern. In Figure 19, the Green2 pixel $G_{2,0,1}$ exists in the first column of the Bayer pattern, and accordingly no other Green pixels exist to the left of pixel $G_{2,0,1}$ (for example, the pixels in dashed lines may be virtual pixels). Determining neighboring pixels with respect to pixel $G_{2,0,1}$ may be performed in various ways. For example, in one embodiment GAS (or other green data modification) may be performed based on the values of the two neighboring pixels $G_{1,1,0}$ and $G_{1,1,2}$. In another embodiment that may be advantageous for ease of implementation in the camera, each of pixels $G_{1,1,0}$ and $G_{1,1,2}$ may be virtually mirrored, as shown in Figure 19 with pixels $G_{1,1,0_virtual}$ and $G_{1,1,2_virtual}$ (shown in dashed lines). In this embodiment GAS may be performed based on the values of the pixels $G_{1,1,0}$, $G_{1,1,2}$, $G_{1,1,0_virtual}$, and $G_{1,1,2_virtual}$. Virtually mirroring of pixels may be implemented in hardware devices and/or software instructions executed by a hardware processor.

[0143] Mirroring of pixel values for calculations of average green values at the edges of the Bayer pattern may similarly, in various embodiments, be implemented for Red/Blue pixels and for pixels in a first row, last row, first column, and/or last column. For example, referring to Table 1 below:

- When processing a first Bayer row, then Green1_01 may be copied/mirrored for Green1_00 and Green1_11 for Green1_10.
- When processing a last Bayer row, then Green1_00 may be copied/mirrored for Green1_01 and Green1_10 for Green1_11.
- When processing a first Bayer column, then Green1_10 may be copied/mirrored for Green1_00 and Green1_11 for Green1_01.
- When processing a last Bayer column, then Green1_00 may be copied/mirrored for Green1_10 and Green1_01 for Green1_11.

Green1_00		Green1_10
	Green2	
Green1_01		Green1_11

Table 1

[0144] Green Average Subtraction may be applied on the Red/Blue data path and/or Green2 data after a Pre-Emphasis function is applied to the image data in some embodiments (e.g., after block 54 of Figure 8). In some embodiments, following GAS, Green channel data and the Red/Blue channel data may be synchronized since the average green value from the Green data path is used to perform Green Average Subtraction in the Red/Blue Data path.

GAS Calculation

[0145] In an embodiment, image data may captured, processed, and stored with 16-bit precision. For example, image sensor 18 and image processing module 20 (shown in Figure 1) may capture and process 16-bit image data. In various embodiments, the image sensor 18 and image processing module 20 may capture and process image data suitable for cinema applications, such as at least 12-bit, 13-bit, 14-bit, 15-bit, or 16-bit image data, or higher, although lower bit-depths can be employed in some cases (e.g., at least 10-bit or at least 11-bit image data). 16-bit precision allows capture and storage of image data in which red, blue, and green data (for example, color intensity data for each pixel) may range on a scale from 0-65,535. Accordingly, Green Average Subtraction on the Red/Blue and Green2

data paths may be implemented by first performing an average calculation on neighboring green pixels (as described above) to determine a GreenAverage. For example, a Green1 Average calculation may be defined as $(\text{Green1_00} + \text{Green1_01} + \text{Green1_10} + \text{Green1_11}) \gg 2$, where “ $\gg 2$ ” indicates a left shift by two operation (causing a division by 4). Then a subtraction calculation may be implemented to subtract the average value from the target pixel value. In an embodiment, following the subtraction calculation the resulting value may be left shifted by one bit (to implement a divide by 2 operation), as follows:

$$\text{RedBlue_GAS}[15:0] = (\text{RedBlue}[15:0] - \text{GreenAverage}[15:0] + 2^{16}) / 2; \text{ and}$$

$$\text{Green2_GAS}[15:0] = (\text{Green2}[15:0] - \text{Green1Average}[15:0] + 2^{16}) / 2$$

[0146] In an embodiment, division by 2 in the RedBlue_GAS and Green2_GAS operations may bring the GAS data into the same dynamic range as the unmodified Green data (for example, Green1 data). The division operation may be implemented as a logical shift by one bit and, in particular implementations a one-half-bit loss of precision may be incurred during this step. In an embodiment, a one-half-bit loss of precision may advantageously enable for faster processing of image data and reduced bandwidth requirements. However, in some embodiments the GAS calculation may be implemented such that there is no loss of precision. For example, an extra buffering bit may be added in the processing pipeline to represent the RedBlue_GAS and Green2_GAS, and/or the RedBlue_GAS and Green2_GAS may not be divided by 2.

[0147] In some embodiments, the RedBlue_GAS value and/or the Green2_GAS value may be calculated using one of the techniques described above, e.g., the techniques described with respect to block 56 of Figures 8 and 8A and as shown and described with respect to Figures 9 and 10.

[0148] In various embodiments, inverse green data modification, which in the case of Green Average Subtraction, is referred to herein as De-GAS, may be used to reverse the effect of the green data modification transform that was performed upstream in the Sensor Data Path. Figure 20 shows a flowchart 200 of a control routine that may be used with the system of Figure 1 to De-GAS image data, according to various embodiments. Flowchart 200 may represent a control routine stored in a memory device, such as the storage device 24, or another storage device within the camera 10. Additionally, a central processing unit (CPU)

may be configured to execute the control routine. The flowchart 200 may include more or fewer blocks, and/or the blocks may be arranged in a different order than shown in Figure 20. Certain aspects of the flowchart 200 may be similar to the flowcharts 60 and 60' of Figures 12 and 12A described above. Accordingly, certain details regarding flowchart 200 may be found above in the description above with respect to Figures 12 and 12A, where applicable.

[0149] At block 202, a decompression algorithm may be applied to the compressed and GASed image data (for example, similar to block 62 for flowchart 60). At block 204 average green values may be calculated based on, for example, Green1 and/or Green2 image data. For example, in an embodiment in which GAS has not been applied to the Green1 image data, Green1 pixels neighboring the Green2 pixels may be determined and averages may be calculated, as described above. At block 206, Green2 pixels may be reconstructed based on the calculated Green1 average values. For example, the Green1 average values may be added back into the Green2 pixel data. At block 208, Red/Blue pixels may be reconstructed based on the calculated Green1 average values and/or calculated Green1 and Green2 average values. At block 209, the reconstructed image data may be filtered and/or denoised (as described above).

[0150] In various embodiments, additional blocks may be included in flowchart 200. For example, Green1 and/or Green1 and Green2 image data may be demosaiced, and/or Red/Blue image data may be demosaiced prior to reconstruction of the Red, Blue, and/or Green image data. In another example, filtering and/or denoising may be applied to the image data at any point in the flowchart 200 (for example, as is shown in flowcharts of Figures 12 and 12A).

[0151] An example subsystem for reversing the GAS process is shown in Figure 21. The subsystem of Figure 21 may reside on the camera (e.g., in the playback module 26) or in software (and/or hardware) executing in a separate computing device, depending on the implementation. As shown in Figure 21, the subsystem may receive, at an Input Mux 210, input either from the Sensor Data Path (shown as "From Frame Rate Conversion," for example, during capture mode, e.g., as part of a monitoring function for live viewing of captured image data) and/or from the Playback Path (for example, during playback mode). Green Average Subtraction may be reversed, or the image data may be De-GASED, by

adding the Green Average back into the Red and Blue pixels in the case of RedBlue_DeGAS, and adding Green1 Average back into the Green2 pixels in the case of Green2_DeGAS. In an embodiment, the De-GAS process may be similar to Green Average Subtraction except that the green average values may be added to, instead of subtracted from, image pixel data. For example, green image data may be passed to Buffer 211 and then to Green Average calculation unit 212. The Green Average calculation unit 212 may output a green average based on the Green1 values and/or the Green2 values, as described above, to a De-GAS calculation unit 213. Further, the red/blue image data may be passed to Buffer 214 and then to the De-GAS calculation unit 213. The De-GAS calculation unit 213 may calculate and output reconstructed values for the Red/Blue image data, while the Green Average calculation unit 212 may output reconstructed values for Green image data.

[0152] In an embodiment, arithmetic equation for De-GAS are as follows:

$$\text{RedBlue_DeGAS}[16:0] = \text{RedBlue_GAS}[16:0] * 2 + \text{GreenAverage}[16:0] - 2^{16};$$

and

$$\text{Green2_DeGAS}[16:0] = \text{Green2_GAS}[16:0] * 2 + \text{Green1Average}[16:0] - 2^{16}$$

[0153] In various embodiments, the RAW path in the Record/Monitor Pre-Process may work on GAS data while a separate RGB path (not shown) may utilize non-GAS data for processing.

Sensor Flip

[0154] In some embodiments, the default Bayer pattern is when red pixels occupy the first line of frame. According to certain embodiments, the term sensor flip denotes when Bayer pattern is such that blue pixels occupy the first line of the frame. When this happens, the algorithm for GAS and De-GAS may change. For example, for a given red or blue pixel, the locations of the 4 neighbor green pixels may differ between the two bayer patterns, as described above.

[0155] According to various embodiments, additional software may not be needed to implement a sensor flip mode. The sensor flip may be automatically determined by using the register Bayer programming of the demosaic block. As such, no additional programming may be necessary.

Additional Embodiments

[0156] According to various embodiments, Green Average Subtraction, as implemented on the Red/Blue and Green channels described above, advantageously enables significant improvements in compressibility of the resulting image data with little or no loss of image information. For example, implementing GAS, as described above, on raw image data may enable processing, compression, and/or storage of the raw image data in a lossy manner (e.g., at compression ratios of at least 3, 4, 5, 6, 7, 8, 9, 10, 11, 12, 13, 14, 15, 16, 17, 18 to 1, or higher), but with little or no visual loss, where the image data is visually lossless or substantially visually lossless upon decompression and playback. In an embodiment, the systems and methods of green data modification (e.g., GAS) involving modification of green data, such as in addition to green data modification on the red and blue data may enable greater than a doubling of compression efficiency (as compared to lossless compression efficiency without GAS on green image channels).

[0157] Thus, in accordance with an embodiment, a video camera can comprise a portable housing, and a lens assembly supported by the housing and configured to focus light. A light sensitive device can be configured to convert the focused light into raw image data with a resolution of at least 2k (or at least about 4k depending on the embodiment), at a frame rate of at least about twenty-three frames per second. The camera can also include a memory device and an image processing system configured to compress and store in the memory device the compressed raw image data using lossy compression (e.g., at a compression ratio of at least 2:1, 3:1, 4:1, or 5:1) and remain substantially visually lossless, and at a rate of at least about 23 frames per second.

[0158] In accordance with yet another embodiment, a video camera can comprise a portable housing having at least one handle configured to allow a user to manipulate the orientation with respect to at least one degree of movement of the housing during a video recording operation of the camera. A lens assembly can comprise at least one lens supported by the housing and configured to focus light at a plane disposed inside the housing. A light sensitive device can be configured to convert the focused light into raw image data with a horizontal resolution of at least 2k (or, in some embodiments, at least 4k) and at a frame rate of at least about twenty three frames per second. A memory device can also be configured to store video image data. An image processing system can be configured to compress and store

in the memory device the raw image data at a compression ratio of at least six to one and remain substantially visually lossless, and at a rate of at least about 23 frames per second.

[0159] Depending on the embodiment, certain acts, events, or functions of any of the algorithms, methods, or processes described herein can be performed in a different sequence, can be added, merged, or left out all together (e.g., not all described acts or events are necessary for the practice of the algorithms). Moreover, in certain embodiments, acts or events can be performed concurrently, e.g., through multi-threaded processing, interrupt processing, or multiple processors or processor cores or on other parallel architectures, rather than sequentially.

[0160] Conditional language used herein, such as, among others, "can," "might," "may," "e.g.," and the like, unless specifically stated otherwise, or otherwise understood within the context as used, is generally intended to convey that certain embodiments include, while other embodiments do not include, certain features, elements and/or states. Thus, such conditional language is not generally intended to imply that features, elements and/or states are in any way required for one or more embodiments or that one or more embodiments necessarily include logic for deciding, with or without author input or prompting, whether these features, elements and/or states are included or are to be performed in any particular embodiment. The terms "comprising," "including," "having," and the like are synonymous and are used inclusively, in an open-ended fashion, and do not exclude additional elements, features, acts, operations, and so forth. Also, the term "or" is used in its inclusive sense (and not in its exclusive sense) so that when used, for example, to connect a list of elements, the term "or" means one, some, or all of the elements in the list. In addition, the articles "a" and "an" are to be construed to mean "one or more" or "at least one" unless specified otherwise.

[0161] Conjunctive language such as the phrase "at least one of X, Y and Z," unless specifically stated otherwise, is otherwise understood with the context as used in general to convey that an item, term, etc. may be either X, Y or Z. Thus, such conjunctive language is not generally intended to imply that certain embodiments require at least one of X, at least one of Y and at least one of Z to each be present.

[0162] While the above detailed description has shown, described, and pointed out novel features as applied to various embodiments, it will be understood that various

omissions, substitutions, and changes in the form and details of the devices or algorithms illustrated can be made without departing from the spirit of the disclosure. Thus, nothing in the foregoing description is intended to imply that any particular feature, characteristic, step, module, or block is necessary or indispensable. As will be recognized, the processes described herein can be embodied within a form that does not provide all of the features and benefits set forth herein, as some features can be used or practiced separately from others. The scope of protection is defined by the appended claims rather than by the foregoing description.

WHAT IS CLAIMED IS:

1. A method of compressing mosaiced color image data, comprising:
 - accessing mosaiced color image data acquired by one or more image sensors of a video camera, the mosaiced color image data comprising a plurality of picture element values for each of a plurality of spatially interleaved color channels, the spatially interleaved color channels comprising a first green color channel, a second green color channel, a red color channel, and a blue color channel;
 - transforming the second green color channel at least partly by, for each respective picture element of a plurality of picture elements of the second green color channel, modifying an initial value corresponding to the respective picture element using a calculated value derived from values of a plurality of picture elements of the first green color channel that are in spatial proximity to the respective picture element;
 - compressing the transformed second green color channel; and
 - storing the transformed, compressed second green color in at least one memory device of the video camera along with compressed versions of the first green color channel, the red color channel, and the blue color channel.
2. The method of Claim 1, wherein said transforming comprises subtracting the calculated value from the initial value.
3. The method of Claim 2, wherein the calculated value comprises an average of the values of the plurality of picture elements of the first green color channel that are in spatial proximity to the respective picture element.
4. The method of Claim 3, wherein the plurality of picture elements of the first green color channel in spatial proximity to the respective picture element comprise at least two picture elements which are diagonally adjacent to the respective picture element.
5. The method of Claim 4, wherein the at least two picture elements include four picture elements of the first green color channel which are diagonally adjacent to the respective picture element.
6. The method of Claim 1, wherein the plurality of picture elements of the first green color channel which are in spatial proximity to the respective picture element include at

least two picture elements, further wherein the respective picture element is positioned between the at least two picture elements.

7. The method of Claim 6, wherein the at least two picture elements include two picture elements which are diagonally opposite one another with respect to the respective picture element.

8. The method of Claim 7, wherein the at least two picture elements include a first pair of picture elements which are diagonally opposite one another with respect to the respective picture element and a second pair of picture elements which are diagonally opposite one another with respect to the respective picture element.

9. The method of Claim 7, wherein the at least two picture elements are diagonally adjacent to the respective picture element.

10. The method of Claim 1, wherein the plurality of picture elements of the first green color which are in spatial proximity to the respective picture element include at least three picture elements.

11. The method of Claim 1, wherein the color image data is mosaiced according to a Bayer pattern.

12. The method of Claim 1, wherein said transforming results in a spatial decorrelation of the first green color channel from the second green color channel.

13. The method of Claim 1, further comprising compressing the first green color channel and storing the compressed first green color channel in the at least one memory device.

14. The method of Claim 1, further comprising:

transforming the red color channel by subtracting from respective picture element values of the red color channel a calculated value derived from picture element values of one or more of the first green color channel and the second green color channel which are in spatial proximity to the respective picture element values of the red color channel;

compressing the transformed red color channel;

transforming the blue color channel by subtracting from respective picture element values of the blue color channel a calculated value derived from picture

element values of one or more of the first green color channel and the second green color channel which are in spatial proximity to the respective picture element values of the blue color channel;

compressing the transformed blue color channel; and

storing the transformed, compressed red and blue color channels in the at least one memory device.

15. The method of Claim 14, wherein said transforming results in a spatial decorrelation of one or more of the first and second green color channels from the red and blue color channels.

16. A video camera, comprising:

at least one memory device;

one or more image sensors configured to convert light incident on the image sensor into color image data, the color image data mosaiced according to a pattern and comprising a plurality of picture element values for each of a plurality of spatially interleaved color channels, the spatially interleaved color channels comprising a first green color channel, a second green color channel, a red color channel, and a blue color channel; and

an image processing module configured to:

transform the second green color channel at least partly by, for each respective picture element of a plurality of picture elements of the second green color channel, modifying an initial value corresponding to the respective picture element using a calculated value derived from values of a plurality of picture elements of the first green color channel that are in spatial proximity to the respective picture element;

compress the transformed second green color channel; and

store the transformed, compressed second green color in the memory device.

17. An apparatus for processing mosaiced color image data, comprising:

at least one memory device;

one or more processors; and

an image processing module executing in the one or more processors and configured to:

access color image data from the memory device, the color image data comprising a plurality of picture element values for each of a plurality of spatially interleaved color channels, the spatially interleaved color channels comprising a first green color channel, a second green color channel, a red color channel, and a blue color channel; and

transform the second green color channel at least partly by, for each respective picture element of a plurality of picture elements of the second green color channel, modifying an initial value corresponding to the respective picture element using a calculated value derived from values of a plurality of picture elements of the first green color channel that are in spatial proximity to the respective picture element; and

compress the transformed second green color channel.

18. A method of decoding color image data, comprising:

accessing encoded color image data for a second green color channel of a plurality of color channels of the color image data, wherein the encoded, color image data was encoded at least partly by:

transforming the second green color channel least partly by, for each respective picture element of a plurality of picture elements of the second green color channel, modifying an initial value corresponding to the respective picture element using a calculated value derived from values of a plurality of picture elements of a first green color channel of the plurality of color channels, the plurality of picture elements of the first green channel in spatial proximity to the respective picture element; and

compressing the transformed second green color channel; and
decoding the accessed color image data for the second green color channel.

19. The method of Claim 18, wherein the decoding comprises substantially reversing the transform operation and performing a decompression operation.

20. The method of Claim 19, wherein substantially reversing the transform operation is performed after performing the decompression operation.

21. The method of Claim 19, wherein substantially reversing the transform operation is performed prior to performing the decompression operation.

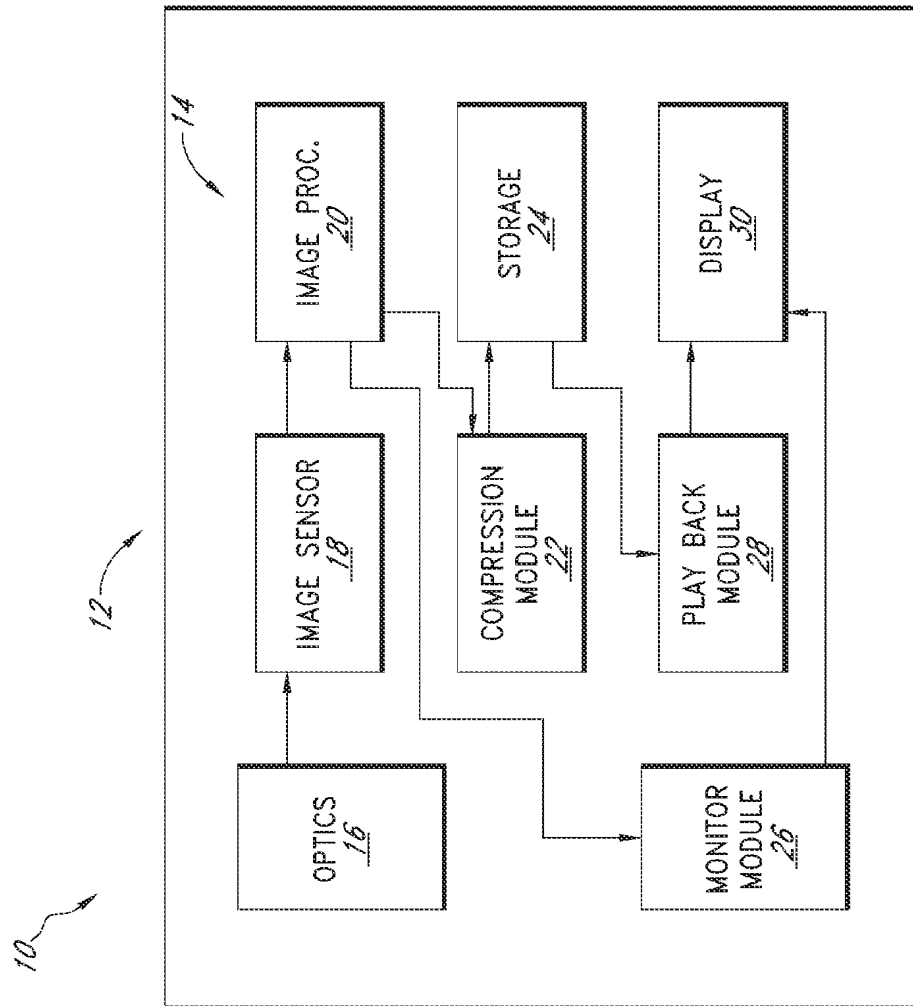

FIG. 1

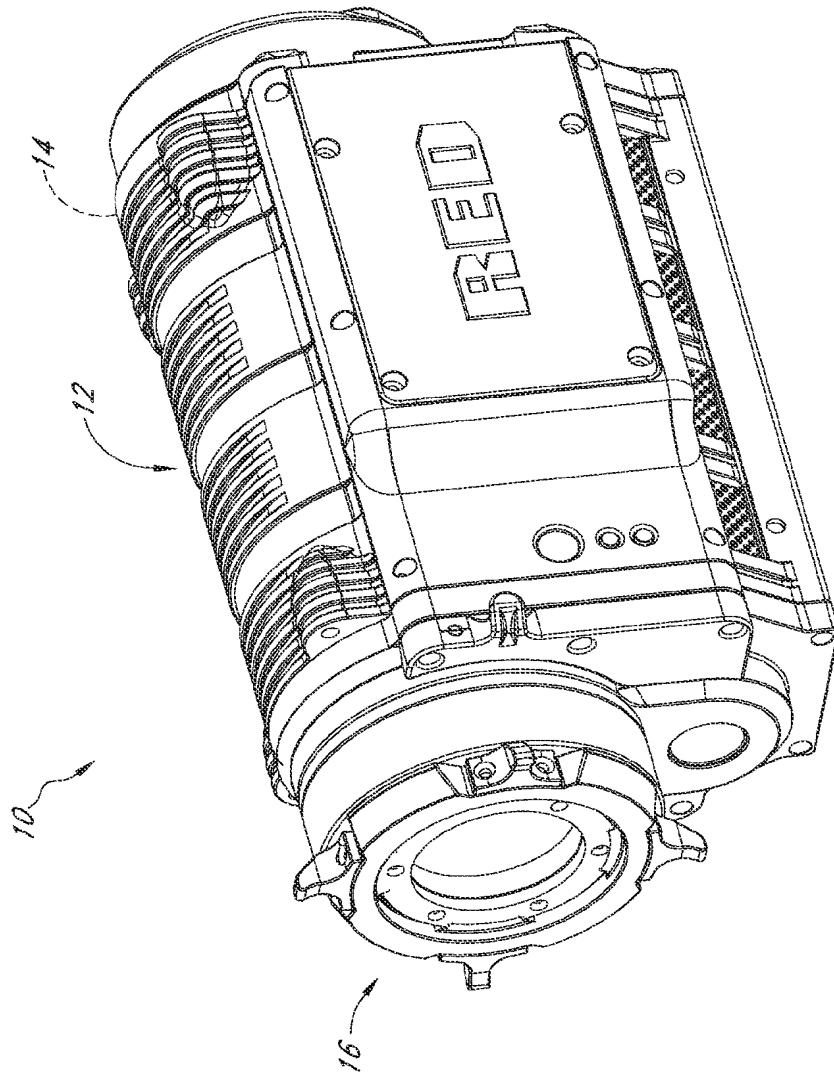

FIG. 2

	$m-3$	$m-2$	$m-1$	m	$m+1$	$m+2$	$m+3$	$m+4$
$n-3$	$B_{m-3,n-3}$	$G_{m-2,n-3}$	$B_{m-1,n-3}$	$G_{m,n-3}$	$B_{m+1,n-3}$	$G_{m+2,n-3}$	$B_{m+3,n-3}$	$G_{m+4,n-3}$
$n-2$	$G_{m-3,n-2}$	$R_{m-2,n-2}$	$G_{m-1,n-2}$	$R_{m,n-2}$	$G_{m+1,n-2}$	$R_{m+2,n-2}$	$G_{m+3,n-2}$	$R_{m+4,n-2}$
$n-1$	$B_{m-3,n-1}$	$G_{m-2,n-1}$	$B_{m-1,n-1}$	$G_{m,n-1}$	$B_{m+1,n-1}$	$G_{m+2,n-1}$	$B_{m+3,n-1}$	$G_{m+4,n-1}$
n	$G_{m-3,n}$	$R_{m-2,n}$	$G_{m-1,n}$	$R_{m,n}$	$G_{m+1,n}$	$R_{m+2,n}$	$G_{m+3,n}$	$R_{m+4,n}$
$n+1$	$B_{m-3,n+1}$	$G_{m-2,n+1}$	$B_{m-1,n+1}$	$G_{m,n+1}$	$B_{m+1,n+1}$	$G_{m+2,n+1}$	$B_{m+3,n+1}$	$G_{m+4,n+1}$
$n+2$	$G_{m-3,n+2}$	$R_{m-2,n+2}$	$G_{m-1,n+2}$	$R_{m,n+2}$	$G_{m+1,n+2}$	$R_{m+2,n+2}$	$G_{m+3,n+2}$	$R_{m+4,n+2}$
$n+3$	$B_{m-3,n+3}$	$G_{m-2,n+3}$	$B_{m-1,n+3}$	$G_{m,n+3}$	$B_{m+1,n+3}$	$G_{m+2,n+3}$	$B_{m+3,n+3}$	$G_{m+4,n+3}$
$n+4$	$G_{m-3,n+4}$	$R_{m-2,n+4}$	$G_{m-1,n+4}$	$R_{m,n+4}$	$G_{m+1,n+4}$	$R_{m+2,n+4}$	$G_{m+3,n+4}$	$R_{m+4,n+4}$

FIG. 3

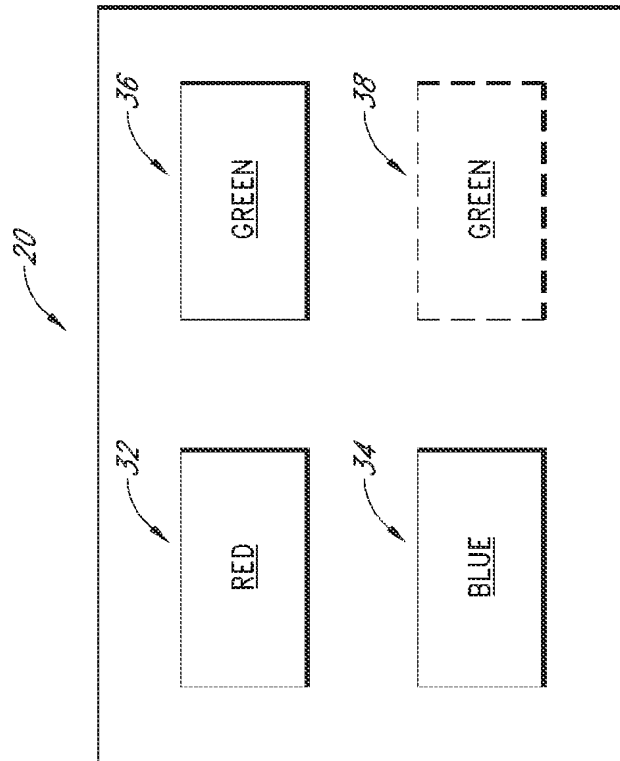

FIG. 4

$m-3$		$G_{m-3,n-2}$		$G_{m-3,n}$		$G_{m-3,n+2}$		$G_{m-3,n+4}$
$m-2$	$G_{m-2,n-3}$		$G_{m-2,n-1}$		$G_{m-2,n+1}$		$G_{m-2,n+3}$	
$m-1$		$G_{m-1,n-2}$		$G_{m-1,n}$		$G_{m-1,n+2}$		$G_{m-1,n+4}$
m	$G_{m,n-3}$		$G_{m,n-1}$		$G_{m,n+1}$		$G_{m,n+3}$	
$m+1$		$G_{m+1,n-2}$		$G_{m+1,n}$		$G_{m+1,n+2}$		$G_{m+1,n+4}$
$m+2$	$G_{m+2,n-3}$		$G_{m+2,n-1}$		$G_{m+2,n+1}$		$G_{m+2,n+3}$	
$m+3$		$G_{m+3,n-2}$		$G_{m+3,n}$		$G_{m+3,n+2}$		$G_{m+3,n+4}$
$m+4$	$G_{m+4,n-3}$		$G_{m+4,n-1}$		$G_{m+4,n+1}$		$G_{m+4,n+3}$	

FIG. 5

$m+4$							
$m+3$		$G_{m+3,n+2}$		$G_{m+3,n}$		$G_{m+3,n+2}$	
$m+2$							
$m+1$		$G_{m+1,n+2}$		$G_{m+1,n}$		$G_{m+1,n+2}$	
m							
$m-1$		$G_{m-1,n+2}$		$G_{m-1,n}$		$G_{m-1,n+2}$	
$m-2$							
$m-3$		$G_{m-3,n+2}$		$G_{m-3,n}$		$G_{m-3,n+2}$	
	$n-3$	$n-2$	$n-1$	n	$n+1$	$n+2$	$n+3$
							$n+4$

FIG. 6

$G_{m-3,n-2}$	$G_{m-1,n-2}$	$G_{m+1,n-2}$	$G_{m+3,n-2}$
$G_{m-3,n}$	$G_{m-1,n}$	$G_{m+1,n}$	$G_{m+3,n}$
$G_{m-3,n+2}$	$G_{m-1,n+2}$	$G_{m+1,n+2}$	$G_{m+3,n+2}$
$G_{m-3,n+4}$	$G_{m-1,n+4}$	$G_{m+1,n+4}$	$G_{m+3,n+4}$

GREEN 2

$R_{m-2,n-2}$	$R_{m,n-2}$	$R_{m+2,n-2}$	$R_{m+4,n-2}$
$R_{m-2,n}$	$R_{m,n}$	$R_{m+2,n}$	$R_{m+4,n}$
$R_{m-2,n+2}$	$R_{m,n+2}$	$R_{m+2,n+2}$	$R_{m+4,n+2}$
$R_{m-2,n+4}$	$R_{m,n+4}$	$R_{m+2,n+4}$	$R_{m+4,n+4}$

RED

$G_{m-2,n-3}$	$G_{m,n-3}$	$G_{m+2,n-3}$	$G_{m+4,n-3}$
$G_{m-2,n-1}$	$G_{m,n-1}$	$G_{m+2,n-1}$	$G_{m+4,n-1}$
$G_{m-2,n+1}$	$G_{m,n+1}$	$G_{m+2,n+1}$	$G_{m+4,n+1}$
$G_{m-2,n+3}$	$G_{m,n+3}$	$G_{m+2,n+3}$	$G_{m+4,n+3}$

GREEN 1

$B_{m-3,n-3}$	$B_{m-1,n-3}$	$B_{m+1,n-3}$	$B_{m+3,n-3}$
$B_{m-3,n-1}$	$B_{m-1,n-1}$	$B_{m+1,n-1}$	$B_{m+3,n-1}$
$B_{m-3,n+1}$	$B_{m-1,n+1}$	$B_{m+1,n+1}$	$B_{m+3,n+1}$
$B_{m-3,n+3}$	$B_{m-1,n+3}$	$B_{m+1,n+3}$	$B_{m+3,n+3}$

BLUE

FIG. 7

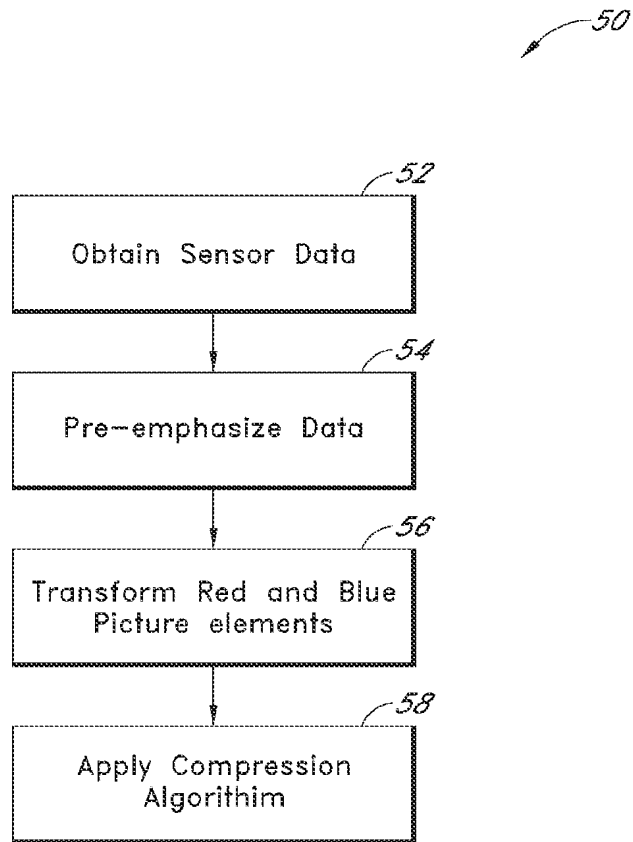

FIG. 8

9/23

50'

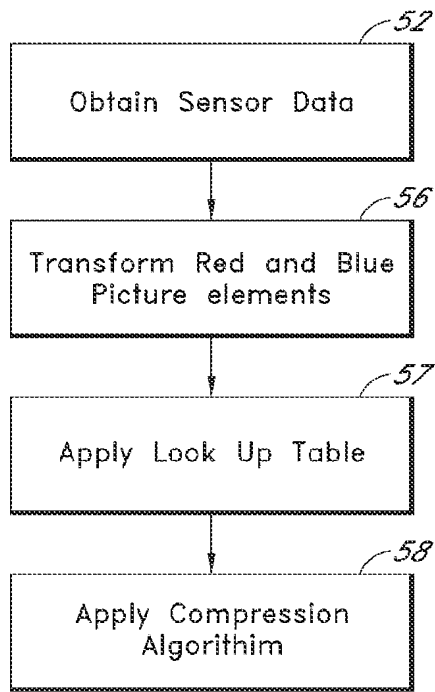

FIG. 8A

10/23

	$B'_{m-1,n-1} =$ $B_{m-1,n-1} -$ $(G_{m-1,n-2} + G_{m,n-1} +$ $G_{m-1,n} + G_{m-2,n-1})/4$		

FIG. 9

	$R'_{m-2,n-2} =$ $R_{m-2,n-2} -$ $(G_{m-2,n-3} + G_{m-1,n-2} +$ $G_{m-2,n-1} + G_{m-3,n-2})/4$		

FIG. 10

12/23

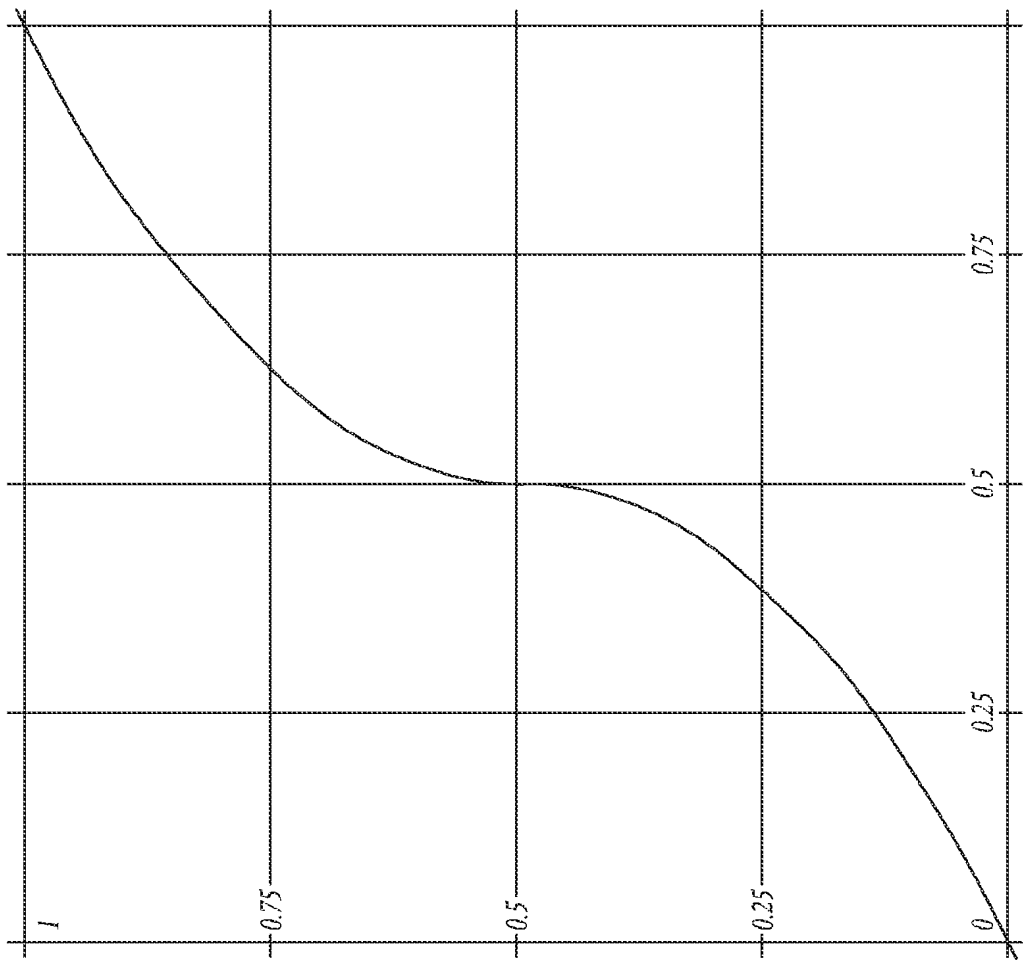

FIG. 11

60

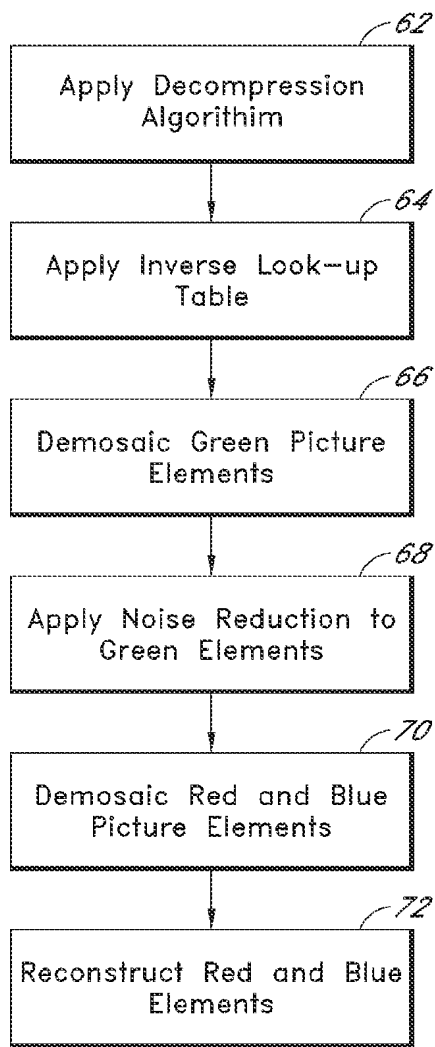

FIG. 12

60'

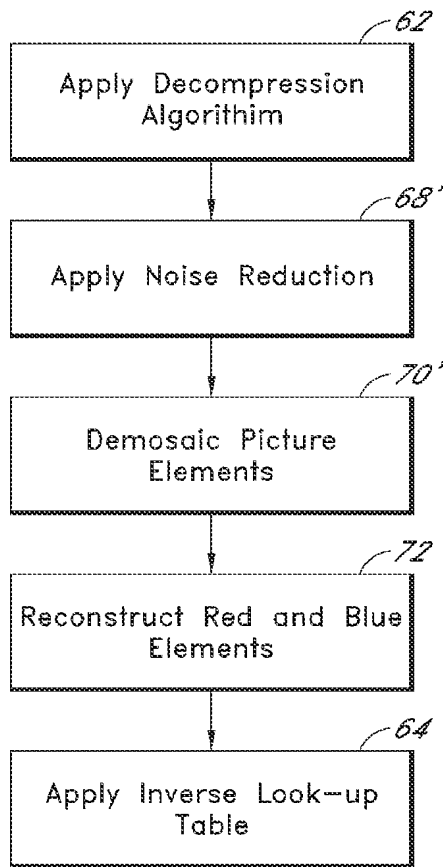

FIG. 12A

	$m-3$	$m-2$	$m-1$	m	$m+1$	$m+2$	$m+3$	$m+4$
$n-3$	$DG_{m-3,n-3}$	$G_{m-2,n-3}$	$DG_{m-1,n-3}$	$G_{m,n-3}$	$DG_{m+1,n-3}$	$G_{m+2,n-3}$	$DG_{m+3,n-3}$	$G_{m+4,n-3}$
$n-2$	$G_{m-3,n-2}$	$DG_{m-2,n-2}$	$G_{m-1,n-2}$	$DG_{m,n-2}$	$G_{m+1,n-2}$	$DG_{m+2,n-2}$	$G_{m+3,n-2}$	$DG_{m+4,n-2}$
$n-1$	$DG_{m-3,n-1}$	$G_{m-2,n-1}$	$DG_{m-1,n-1}$	$G_{m,n-1}$	$DG_{m+1,n-1}$	$G_{m+2,n-1}$	$DG_{m+3,n-1}$	$G_{m+4,n-1}$
n	$G_{m-3,n}$	$DG_{m-2,n}$	$G_{m-1,n}$	$DG_{m,n}$	$G_{m+1,n}$	$DG_{m+2,n}$	$G_{m+3,n}$	$DG_{m+4,n}$
$n+1$	$DG_{m-3,n+1}$	$G_{m-2,n+1}$	$DG_{m-1,n+1}$	$G_{m,n+1}$	$DG_{m+1,n+1}$	$G_{m+2,n+1}$	$DG_{m+3,n+1}$	$G_{m+4,n+1}$
$n+2$	$G_{m-3,n+2}$	$DG_{m-2,n+2}$	$G_{m-1,n+2}$	$DG_{m,n+2}$	$G_{m+1,n+2}$	$DG_{m+2,n+2}$	$G_{m+3,n+2}$	$DG_{m+4,n+2}$
$n+3$	$DG_{m-3,n+3}$	$G_{m-2,n+3}$	$DG_{m-1,n+3}$	$G_{m,n+3}$	$DG_{m+1,n+3}$	$G_{m+2,n+3}$	$DG_{m+3,n+3}$	$G_{m+4,n+3}$
$n+4$	$G_{m-3,n+4}$	$DG_{m-2,n+4}$	$G_{m-1,n+4}$	$DG_{m,n+4}$	$G_{m+1,n+4}$	$DG_{m+2,n+4}$	$G_{m+3,n+4}$	$DG_{m+4,n+4}$

FIG. 13

	$m-3$	$m-2$	$m-1$	m	$m+1$	$m+2$	$m+3$	$m+4$
$n-3$	$DG_{m-3,n-3}$	$DG_{m-2,n-3}$	$DG_{m-1,n-3}$	$DG_{m,n-3}$	$DG_{m+1,n-3}$	$DG_{m+2,n-3}$	$DG_{m+3,n-3}$	$DG_{m+4,n-3}$
$n-2$	$G_{m-3,n-2}$	$DG_{m-2,n-2}$	$G_{m-1,n-2}$	$DG_{m,n-2}$	$G_{m+1,n-2}$	$DG_{m+2,n-2}$	$G_{m+3,n-2}$	$DG_{m+4,n-2}$
$n-1$	$DG_{m-3,n-1}$	$DG_{m-2,n-1}$	$DG_{m-1,n-1}$	$DG_{m,n-1}$	$DG_{m+1,n-1}$	$DG_{m+2,n-1}$	$DG_{m+3,n-1}$	$DG_{m+4,n-1}$
n	$G_{m-3,n}$	$DG_{m-2,n}$	$G_{m-1,n}$	$DG_{m,n}$	$G_{m+1,n}$	$DG_{m+2,n}$	$G_{m+3,n}$	$DG_{m+4,n}$
$n+1$	$DG_{m-3,n+1}$	$DG_{m-2,n+1}$	$DG_{m-1,n+1}$	$DG_{m,n+1}$	$DG_{m+1,n+1}$	$DG_{m+2,n+1}$	$DG_{m+3,n+1}$	$DG_{m+4,n+1}$
$n+2$	$G_{m-3,n+2}$	$DG_{m-2,n+2}$	$G_{m-1,n+2}$	$DG_{m,n+2}$	$G_{m+1,n+2}$	$DG_{m+2,n+2}$	$G_{m+3,n+2}$	$DG_{m+4,n+2}$
$n+3$	$DG_{m-3,n+3}$	$DG_{m-2,n+3}$	$DG_{m-1,n+3}$	$DG_{m,n+3}$	$DG_{m+1,n+3}$	$DG_{m+2,n+3}$	$DG_{m+3,n+3}$	$DG_{m+4,n+3}$
$n+4$	$G_{m-3,n+4}$	$DG_{m-2,n+4}$	$G_{m-1,n+4}$	$DG_{m,n+4}$	$G_{m+1,n+4}$	$DG_{m+2,n+4}$	$G_{m+3,n+4}$	$DG_{m+4,n+4}$

FIG. 14

	$m+4$							
	$m+3$	$B_{m+3,n-3}$		$B_{m+3,n-1}$		$B_{m+3,n+1}$		$B_{m+3,n+3}$
	$m+2$							
	$m+1$	$B_{m+1,n-3}$		$B_{m+1,n-1}$		$B_{m+1,n+1}$		$B_{m+1,n+3}$
	m							
	$m-1$	$B_{m-1,n-3}$		$B_{m-1,n-1}$		$B_{m-1,n+1}$		$B_{m-1,n+3}$
	$m-2$							
	$m-3$	$B_{m-3,n-3}$		$B_{m-3,n-1}$		$B_{m-3,n+1}$		$B_{m-3,n+3}$
$n-3$								
$n-2$								
$n-1$								
n								
$n+1$								
$n+2$								
$n+3$								
$n+4$								

FIG. 15

	$m-3$	$m-2$	$m-1$	m	$m+1$	$m+2$	$m+3$	$m+4$
$n-3$	$B_{m-3,n-3}$	$DB_{m-2,n-3}$	$B_{m-1,n-3}$	$DB_{m,n-3}$	$B_{m+1,n-3}$	$DB_{m+2,n-3}$	$B_{m+3,n-3}$	$DB_{m+4,n-3}$
$n-2$	$DB_{m-3,n-2}$	$DB_{m-2,n-2}$	$DB_{m-1,n-2}$	$DB_{m,n-2}$	$DB_{m+1,n-2}$	$DB_{m+2,n-2}$	$DB_{m+3,n-2}$	$DB_{m+4,n-2}$
$n-1$	$B_{m-3,n-1}$	$DB_{m-2,n-1}$	$B_{m-1,n-1}$	$DB_{m,n-1}$	$B_{m+1,n-1}$	$DB_{m+2,n-1}$	$B_{m+3,n-1}$	$DB_{m+4,n-1}$
n	$DB_{m-3,n}$	$DB_{m-2,n}$	$DB_{m-1,n}$	$DB_{m,n}$	$DB_{m+1,n}$	$DB_{m+2,n}$	$DB_{m+3,n}$	$DB_{m+4,n}$
$n+1$	$B_{m-3,n+1}$	$DB_{m-2,n+1}$	$B_{m-1,n+1}$	$DB_{m,n+1}$	$B_{m+1,n+1}$	$DB_{m+2,n+1}$	$B_{m+3,n+1}$	$DB_{m+4,n+1}$
$n+2$	$DB_{m-3,n+2}$	$DB_{m-2,n+2}$	$DB_{m-1,n+2}$	$DB_{m,n+2}$	$DB_{m+1,n+2}$	$DB_{m+2,n+2}$	$DB_{m+3,n+2}$	$DB_{m+4,n+2}$
$n+3$	$B_{m-3,n+3}$	$DB_{m-2,n+3}$	$B_{m-1,n+3}$	$DB_{m,n+3}$	$B_{m+1,n+3}$	$DB_{m+2,n+3}$	$B_{m+3,n+3}$	$DB_{m+4,n+3}$
$n+4$	$DB_{m-3,n+4}$	$DB_{m-2,n+4}$	$DB_{m-1,n+4}$	$DB_{m,n+4}$	$DB_{m+1,n+4}$	$DB_{m+2,n+4}$	$DB_{m+3,n+4}$	$DB_{m+4,n+4}$

FIG. 16

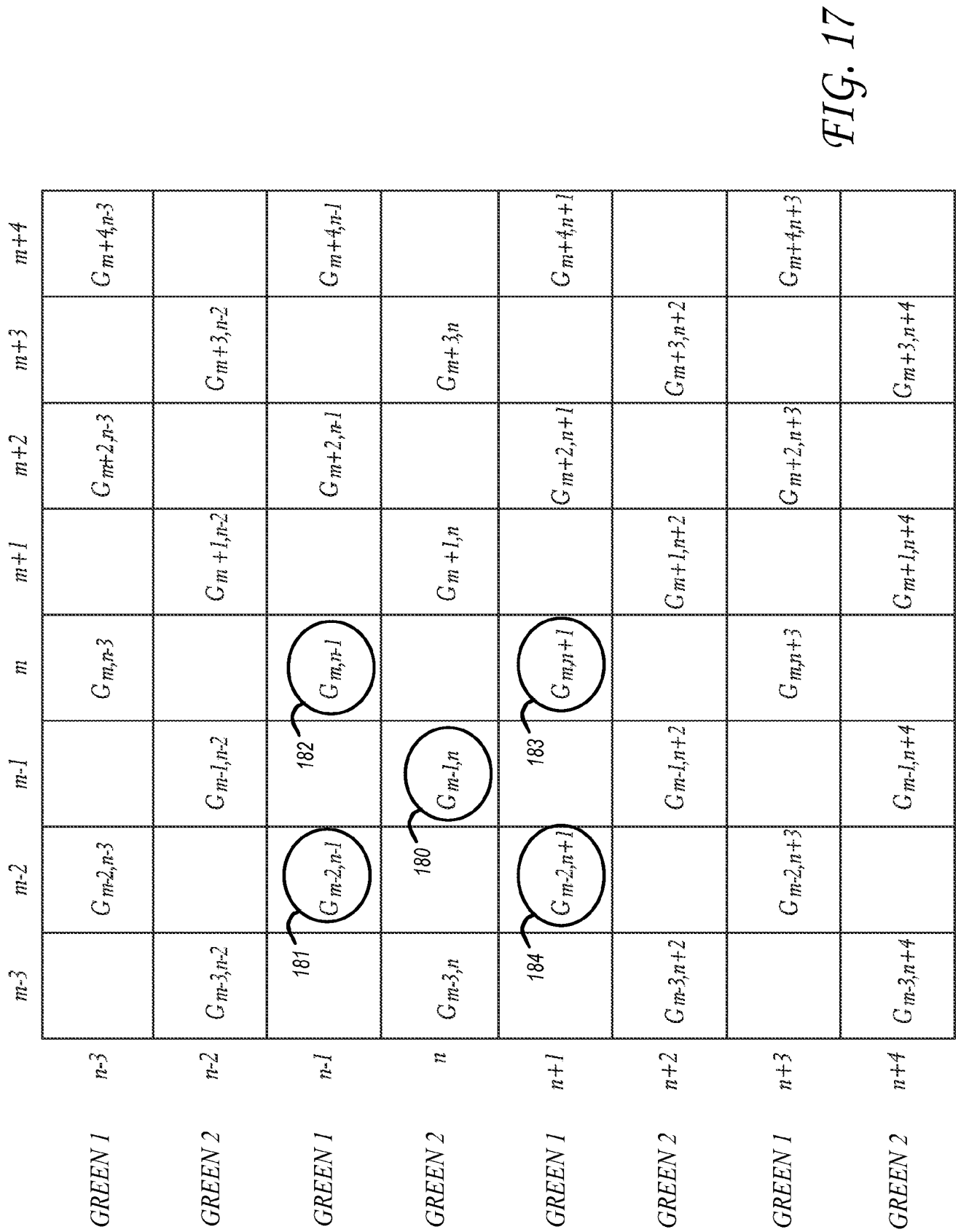

FIG. 17

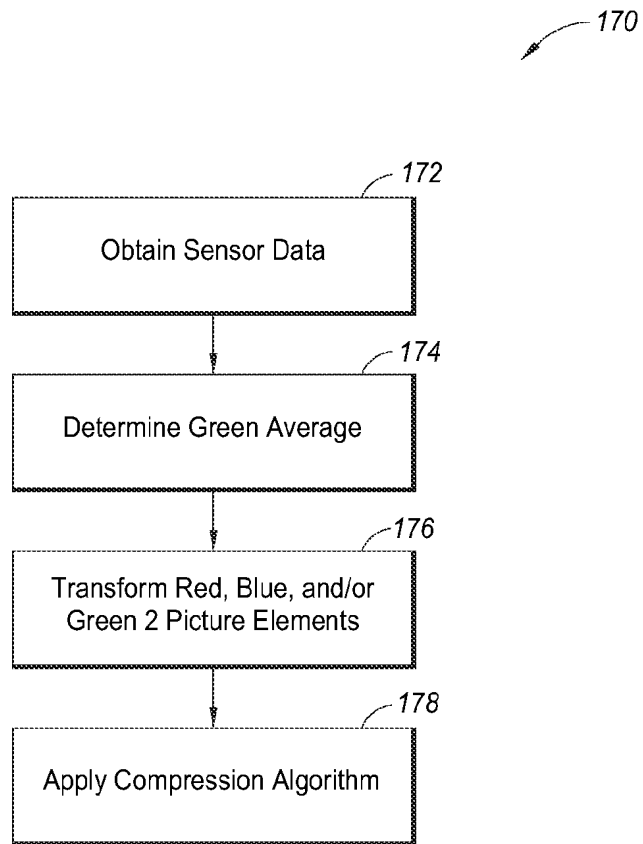
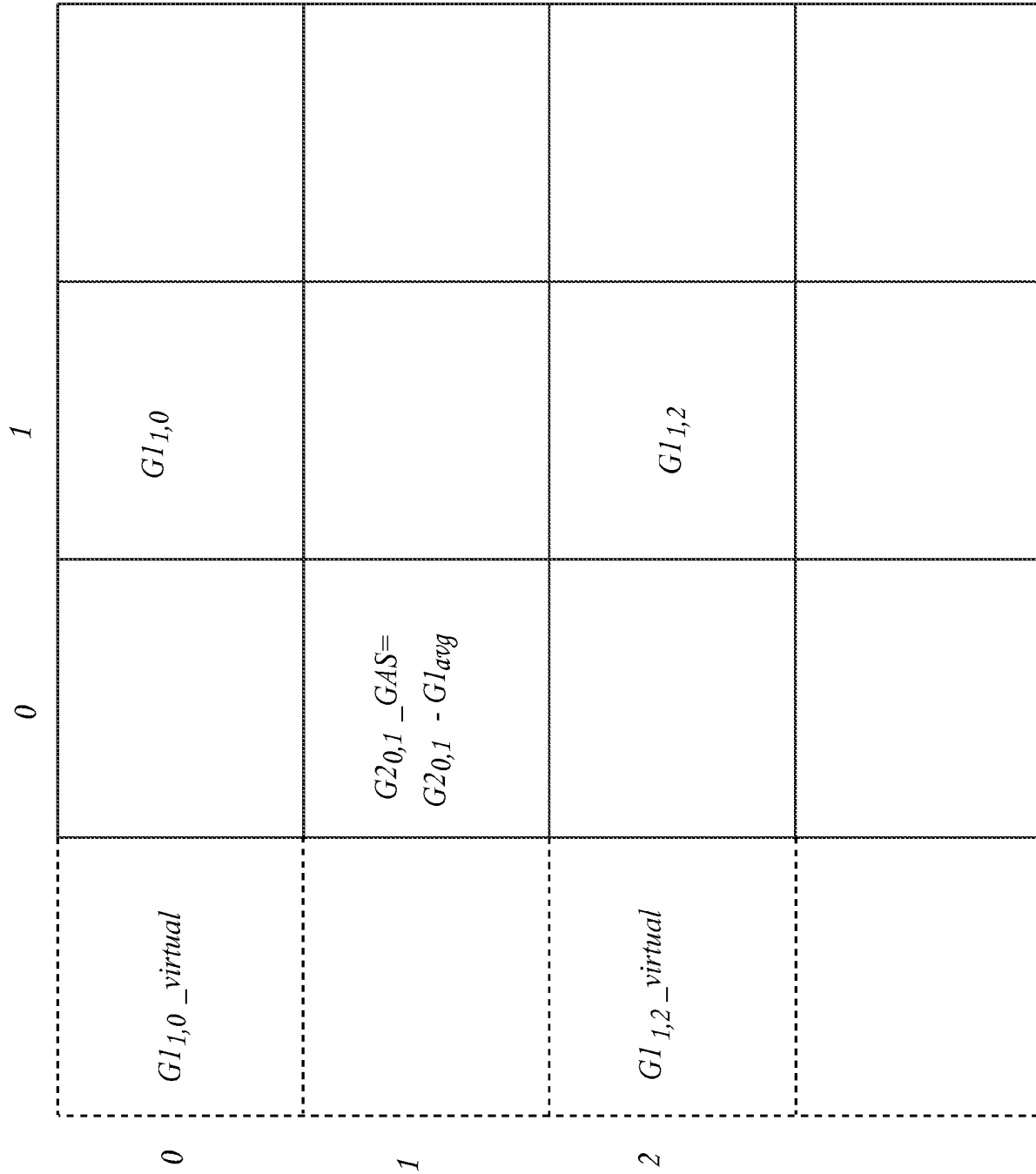

FIG. 18

FIG. 19



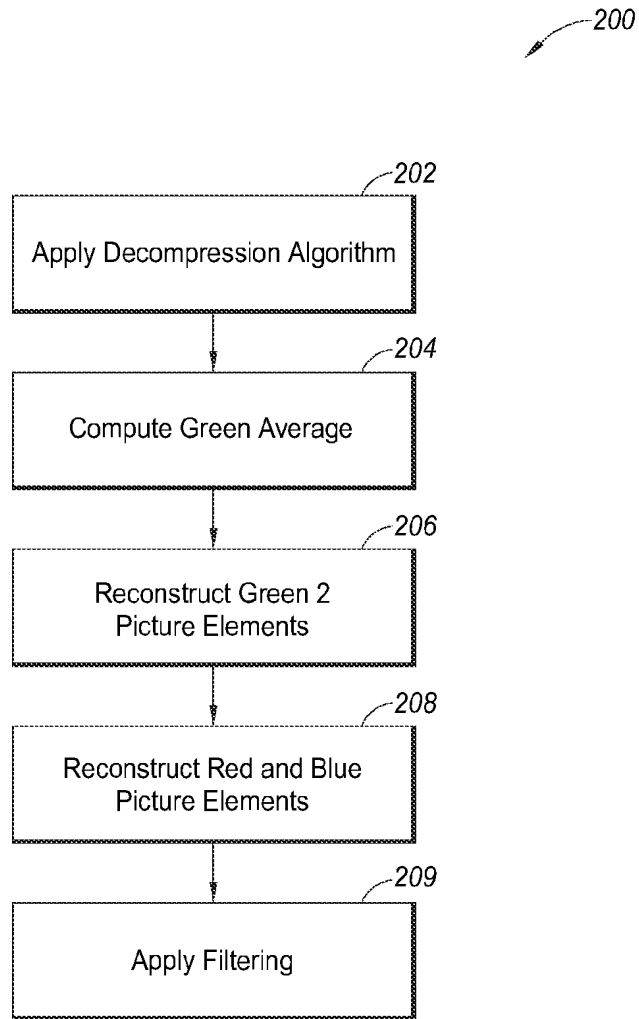

FIG. 20

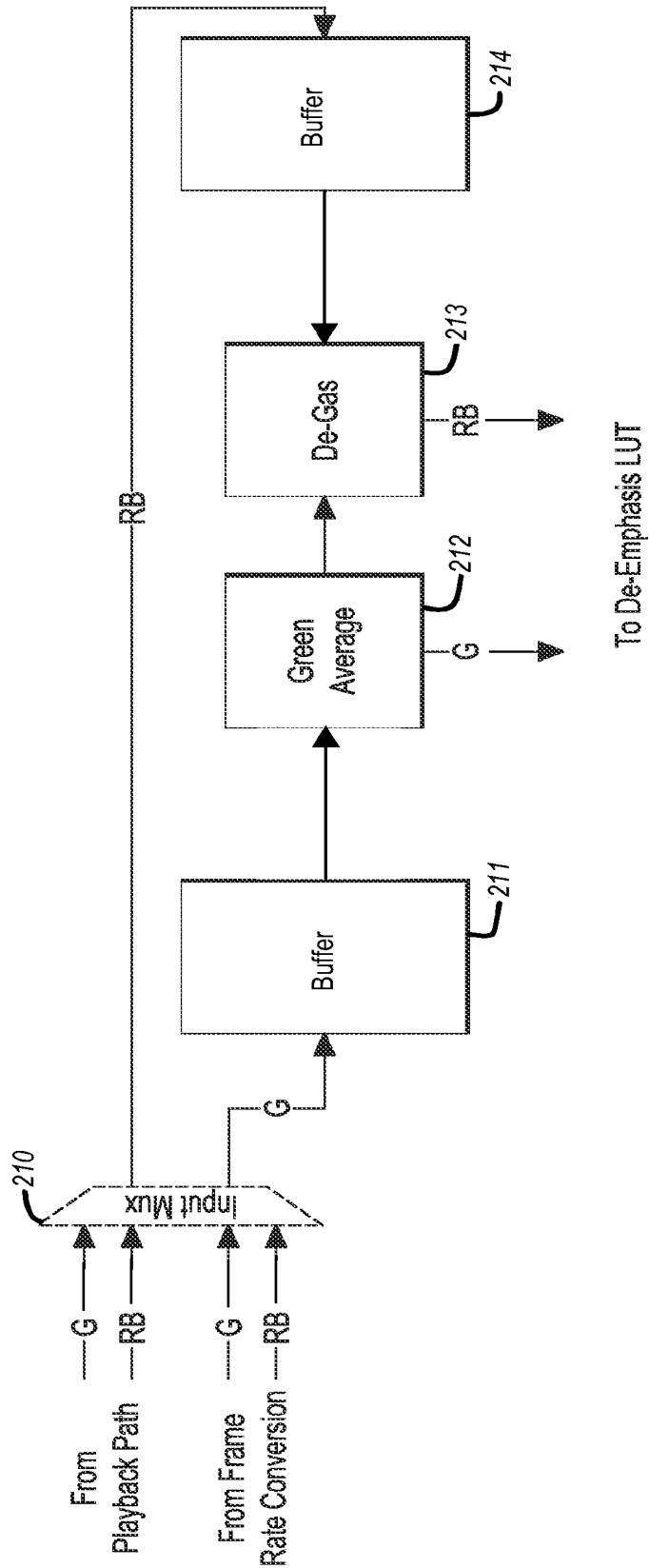

FIG. 21

Electronic Acknowledgement Receipt

EFS ID:	24185830
Application Number:	14485612
International Application Number:	
Confirmation Number:	1068
Title of Invention:	VIDEO CAMERA
First Named Inventor/Applicant Name:	James H. Jannard
Customer Number:	20995
Filer:	Sean Patrick Ambrosius/Daniella Kellogg
Filer Authorized By:	Sean Patrick Ambrosius
Attorney Docket Number:	REDCOM.007C4
Receipt Date:	24-NOV-2015
Filing Date:	12-SEP-2014
Time Stamp:	19:12:36
Application Type:	Utility under 35 USC 111(a)

Payment information:

Submitted with Payment	no
------------------------	----

File Listing:

Document Number	Document Description	File Name	File Size(Bytes)/ Message Digest	Multi Part /.zip	Pages (if appl.)
1		IDS_REDCOM-007C4.pdf	55982 <small>449d8700c6eb2d90bb2eb4d13c8928039385355b</small>	yes	3

Multipart Description/PDF files in .zip description			
	Document Description	Start	End
	Transmittal Letter	1	2
	Information Disclosure Statement (IDS) Form (SB08)	3	3

Warnings:

Information:

2	Foreign Reference	WO2014127153.pdf	3170009	no	71
			36978ac42f0c401941c84948098e4185c7aa512a		

Warnings:

Information:

Total Files Size (in bytes):		3225991
-------------------------------------	--	---------

This Acknowledgement Receipt evidences receipt on the noted date by the USPTO of the indicated documents, characterized by the applicant, and including page counts, where applicable. It serves as evidence of receipt similar to a Post Card, as described in MPEP 503.

New Applications Under 35 U.S.C. 111

If a new application is being filed and the application includes the necessary components for a filing date (see 37 CFR 1.53(b)-(d) and MPEP 506), a Filing Receipt (37 CFR 1.54) will be issued in due course and the date shown on this Acknowledgement Receipt will establish the filing date of the application.

National Stage of an International Application under 35 U.S.C. 371

If a timely submission to enter the national stage of an international application is compliant with the conditions of 35 U.S.C. 371 and other applicable requirements a Form PCT/DO/EO/903 indicating acceptance of the application as a national stage submission under 35 U.S.C. 371 will be issued in addition to the Filing Receipt, in due course.

New International Application Filed with the USPTO as a Receiving Office

If a new international application is being filed and the international application includes the necessary components for an international filing date (see PCT Article 11 and MPEP 1810), a Notification of the International Application Number and of the International Filing Date (Form PCT/RO/105) will be issued in due course, subject to prescriptions concerning national security, and the date shown on this Acknowledgement Receipt will establish the international filing date of the application.

INFORMATION DISCLOSURE STATEMENT

Inventor	: James H. Jannard
App. No.	: 14/485612
Filed	: September 12, 2014
For	: VIDEO CAMERA
Examiner	: Diep, Trung T.
Art Unit	: 2664
Conf. No.	: 1068

Commissioner for Patents
P.O. Box 1450
Alexandria, VA 22313-1450

References and Listing

Pursuant to 37 CFR 1.56, an Information Disclosure Statement listing references is provided herewith. Pursuant to 37 C.F.R § 1.97(g) and (h), Applicants make no representation that the information is considered to be material to patentability. Additionally, inclusion on this list is not an admission that any of the cited documents are prior art in this application. Further, Applicants make no representation regarding the completeness of this list, or that better art does not exist.

Applicant wishes to draw the Examiner's attention to the following applications owned by of the present application's assignee:

Docket No.	Serial No.	Patent/ Publication No	Title	Filed
REDCOM.007A	12/101,882	8,174,560	VIDEO CAMERA	04/11/2008
REDCOM.007CP1	12/422,507	8,237,830	VIDEO CAMERA	04/13/2009
REDCOM.007CP1C1	12/834,854	7,830,967	VIDEO CAMERA	07/12/2010
REDCOM.007C1	13/464,803	8,872,933	VIDEO CAMERA	05/04/2012
REDCOM.007C2	13/566,868	8,358,357	VIDEO CAMERA	08/03/2012
REDCOM.007CP1C2	13/566,924	8,878,952	VIDEO CAMERA	08/03/2012
REDCOM.007X1 (reexamination REDCOM.007A)	90/012,550	8,174,560 C1	VIDEO CAMERA	09/13/2012

Application No.: 14/485612
Filing Date: September 12, 2014

Docket No.	Serial No.	Patent/ Publication No	Title	Filed
REDCOM.007C3	14/485,611	2015/0003801	VIDEO CAMERA	09/12/2014
REDCOM.007P1C3	14/488,030	9,019,393	VIDEO PROCESSING SYSTEM AND METHOD	09/16/2014
REDCOM.007P1C4	14/609,090	N/A	VIDEO CAMERA	01/29/2015

Applicant notes that cited references, office actions, responses and notices of allowance currently exist or will exist for the above-referenced matters. Applicant also understands that the Examiner has access to sophisticated online Patent Office computing systems that provide ready access to the full file histories of these matters including, for example, specifications, drawings, pending claims, cited art, office actions, responses, declarations, and notices of allowance. Rather than submit copies these file histories, Applicant respectfully requests that the Examiner continue to review these file histories online for past, current, and future information about these matters. Also, if the Examiner cannot readily access these file histories, the Applicant would be pleased to provide any portion of any of the file histories at any time upon specific Examiner request.

No Disclaimers

To the extent that anything in the Information Disclosure Statement or the listed references could be construed as a disclaimer of any subject matter supported by the present application, Applicant hereby rescinds and retracts such disclaimer.

Timing of Disclosure

This Information Disclosure Statement is being filed before receipt of a First Office Action after an RCE, and no fee is believed to be required.

Respectfully submitted,
KNOBBE, MARTENS, OLSON & BEAR, LLP

Dated: November 24, 2015

By: /Sean Ambrosius/ _____
Sean Ambrosius
Registration No. 65,290
Attorney of Record
Customer No. 20995
(949) 760-0404

22140575



NOTICE OF ALLOWANCE AND FEE(S) DUE

20995 7590 12/10/2015
KNOBBE MARTENS OLSON & BEAR LLP
2040 MAIN STREET
FOURTEENTH FLOOR
IRVINE, CA 92614

Table with 2 columns: EXAMINER (DIEP, TRUNG T), ART UNIT (2664), PAPER NUMBER (1068)

DATE MAILED: 12/10/2015

Table with 5 columns: APPLICATION NO., FILING DATE, FIRST NAMED INVENTOR, ATTORNEY DOCKET NO., CONFIRMATION NO.

TITLE OF INVENTION: VIDEO CAMERA

Table with 7 columns: APPLN. TYPE, ENTITY STATUS, ISSUE FEE DUE, PUBLICATION FEE DUE, PREV. PAID ISSUE FEE, TOTAL FEE(S) DUE, DATE DUE

THE APPLICATION IDENTIFIED ABOVE HAS BEEN EXAMINED AND IS ALLOWED FOR ISSUANCE AS A PATENT. PROSECUTION ON THE MERITS IS CLOSED. THIS NOTICE OF ALLOWANCE IS NOT A GRANT OF PATENT RIGHTS. THIS APPLICATION IS SUBJECT TO WITHDRAWAL FROM ISSUE AT THE INITIATIVE OF THE OFFICE OR UPON PETITION BY THE APPLICANT. SEE 37 CFR 1.313 AND MPEP 1308.

THE ISSUE FEE AND PUBLICATION FEE (IF REQUIRED) MUST BE PAID WITHIN THREE MONTHS FROM THE MAILING DATE OF THIS NOTICE OR THIS APPLICATION SHALL BE REGARDED AS ABANDONED. THIS STATUTORY PERIOD CANNOT BE EXTENDED. SEE 35 U.S.C. 151. THE ISSUE FEE DUE INDICATED ABOVE DOES NOT REFLECT A CREDIT FOR ANY PREVIOUSLY PAID ISSUE FEE IN THIS APPLICATION. IF AN ISSUE FEE HAS PREVIOUSLY BEEN PAID IN THIS APPLICATION (AS SHOWN ABOVE), THE RETURN OF PART B OF THIS FORM WILL BE CONSIDERED A REQUEST TO REAPPLY THE PREVIOUSLY PAID ISSUE FEE TOWARD THE ISSUE FEE NOW DUE.

HOW TO REPLY TO THIS NOTICE:

I. Review the ENTITY STATUS shown above. If the ENTITY STATUS is shown as SMALL or MICRO, verify whether entitlement to that entity status still applies.

If the ENTITY STATUS is the same as shown above, pay the TOTAL FEE(S) DUE shown above.

If the ENTITY STATUS is changed from that shown above, on PART B - FEE(S) TRANSMITTAL, complete section number 5 titled "Change in Entity Status (from status indicated above)".

For purposes of this notice, small entity fees are 1/2 the amount of undiscounted fees, and micro entity fees are 1/2 the amount of small entity fees.

II. PART B - FEE(S) TRANSMITTAL, or its equivalent, must be completed and returned to the United States Patent and Trademark Office (USPTO) with your ISSUE FEE and PUBLICATION FEE (if required). If you are charging the fee(s) to your deposit account, section "4b" of Part B - Fee(s) Transmittal should be completed and an extra copy of the form should be submitted. If an equivalent of Part B is filed, a request to reapply a previously paid issue fee must be clearly made, and delays in processing may occur due to the difficulty in recognizing the paper as an equivalent of Part B.

III. All communications regarding this application must give the application number. Please direct all communications prior to issuance to Mail Stop ISSUE FEE unless advised to the contrary.

IMPORTANT REMINDER: Utility patents issuing on applications filed on or after Dec. 12, 1980 may require payment of maintenance fees. It is patentee's responsibility to ensure timely payment of maintenance fees when due.

PART B - FEE(S) TRANSMITTAL

**Complete and send this form, together with applicable fee(s), to: Mail Mail Stop ISSUE FEE
 Commissioner for Patents
 P.O. Box 1450
 Alexandria, Virginia 22313-1450
 or Fax (571)-273-2885**

INSTRUCTIONS: This form should be used for transmitting the ISSUE FEE and PUBLICATION FEE (if required). Blocks 1 through 5 should be completed where appropriate. All further correspondence including the Patent, advance orders and notification of maintenance fees will be mailed to the current correspondence address as indicated unless corrected below or directed otherwise in Block 1, by (a) specifying a new correspondence address; and/or (b) indicating a separate "FEE ADDRESS" for maintenance fee notifications.

CURRENT CORRESPONDENCE ADDRESS (Note: Use Block 1 for any change of address)

Note: A certificate of mailing can only be used for domestic mailings of the Fee(s) Transmittal. This certificate cannot be used for any other accompanying papers. Each additional paper, such as an assignment or formal drawing, must have its own certificate of mailing or transmission.

20995 7590 12/10/2015
KNOBBE MARTENS OLSON & BEAR LLP
 2040 MAIN STREET
 FOURTEENTH FLOOR
 IRVINE, CA 92614

Certificate of Mailing or Transmission

I hereby certify that this Fee(s) Transmittal is being deposited with the United States Postal Service with sufficient postage for first class mail in an envelope addressed to the Mail Stop ISSUE FEE address above, or being facsimile transmitted to the USPTO (571) 273-2885, on the date indicated below.

(Depositor's name)
(Signature)
(Date)

APPLICATION NO.	FILING DATE	FIRST NAMED INVENTOR	ATTORNEY DOCKET NO.	CONFIRMATION NO.
14/485,612	09/12/2014	James H. Jannard	REDCOM.007C4	1068

TITLE OF INVENTION: VIDEO CAMERA

APPLN. TYPE	ENTITY STATUS	ISSUE FEE DUE	PUBLICATION FEE DUE	PREV. PAID ISSUE FEE	TOTAL FEE(S) DUE	DATE DUE
nonprovisional	UNDISCOUNTED	\$960	\$0	\$0	\$960	03/10/2016

EXAMINER	ART UNIT	CLASS-SUBCLASS
DIEP, TRUNG T	2664	348-014000

<p>1. Change of correspondence address or indication of "Fee Address" (37 CFR 1.363).</p> <p><input type="checkbox"/> Change of correspondence address (or Change of Correspondence Address form PTO/SB/122) attached.</p> <p><input type="checkbox"/> "Fee Address" indication (or "Fee Address" Indication form PTO/SB/47; Rev 03-02 or more recent) attached. Use of a Customer Number is required.</p>	<p>2. For printing on the patent front page, list</p> <p>(1) The names of up to 3 registered patent attorneys or agents OR, alternatively, _____ 1</p> <p>(2) The name of a single firm (having as a member a registered attorney or agent) and the names of up to 2 registered patent attorneys or agents. If no name is listed, no name will be printed. _____ 2</p> <p>_____ 3</p>
---	---

3. ASSIGNEE NAME AND RESIDENCE DATA TO BE PRINTED ON THE PATENT (print or type)

PLEASE NOTE: Unless an assignee is identified below, no assignee data will appear on the patent. If an assignee is identified below, the document has been filed for recordation as set forth in 37 CFR 3.11. Completion of this form is NOT a substitute for filing an assignment.

(A) NAME OF ASSIGNEE _____ (B) RESIDENCE: (CITY and STATE OR COUNTRY) _____

Please check the appropriate assignee category or categories (will not be printed on the patent) : Individual Corporation or other private group entity Government

<p>4a. The following fee(s) are submitted:</p> <p><input type="checkbox"/> Issue Fee</p> <p><input type="checkbox"/> Publication Fee (No small entity discount permitted)</p> <p><input type="checkbox"/> Advance Order - # of Copies _____</p>	<p>4b. Payment of Fee(s): (Please first reapply any previously paid issue fee shown above)</p> <p><input type="checkbox"/> A check is enclosed.</p> <p><input type="checkbox"/> Payment by credit card. Form PTO-2038 is attached.</p> <p><input type="checkbox"/> The director is hereby authorized to charge the required fee(s), any deficiency, or credits any overpayment, to Deposit Account Number _____ (enclose an extra copy of this form).</p>
---	--

5. **Change in Entity Status** (from status indicated above)

Applicant certifying micro entity status. See 37 CFR 1.29

Applicant asserting small entity status. See 37 CFR 1.27

Applicant changing to regular undiscounted fee status.

NOTE: Absent a valid certification of Micro Entity Status (see forms PTO/SB/15A and 15B), issue fee payment in the micro entity amount will not be accepted at the risk of application abandonment.

NOTE: If the application was previously under micro entity status, checking this box will be taken to be a notification of loss of entitlement to micro entity status.

NOTE: Checking this box will be taken to be a notification of loss of entitlement to small or micro entity status, as applicable.

NOTE: This form must be signed in accordance with 37 CFR 1.31 and 1.33. See 37 CFR 1.4 for signature requirements and certifications.

Authorized Signature _____ Date _____

Typed or printed name _____ Registration No. _____



UNITED STATES DEPARTMENT OF COMMERCE
United States Patent and Trademark Office
Address: COMMISSIONER FOR PATENTS
P.O. Box 1450
Alexandria, Virginia 22313-1450
www.uspto.gov

Table with 5 columns: APPLICATION NO., FILING DATE, FIRST NAMED INVENTOR, ATTORNEY DOCKET NO., CONFIRMATION NO.
14/485,612 09/12/2014 James H. Jannard REDCOM.007C4 1068

20995 7590 12/10/2015
KNOBBE MARTENS OLSON & BEAR LLP
2040 MAIN STREET
FOURTEENTH FLOOR
IRVINE, CA 92614

EXAMINER

DIEP, TRUNG T

ART UNIT PAPER NUMBER

2664

DATE MAILED: 12/10/2015

Determination of Patent Term Adjustment under 35 U.S.C. 154 (b)

(Applications filed on or after May 29, 2000)

The Office has discontinued providing a Patent Term Adjustment (PTA) calculation with the Notice of Allowance.

Section 1(h)(2) of the AIA Technical Corrections Act amended 35 U.S.C. 154(b)(3)(B)(i) to eliminate the requirement that the Office provide a patent term adjustment determination with the notice of allowance. See Revisions to Patent Term Adjustment, 78 Fed. Reg. 19416, 19417 (Apr. 1, 2013). Therefore, the Office is no longer providing an initial patent term adjustment determination with the notice of allowance. The Office will continue to provide a patent term adjustment determination with the Issue Notification Letter that is mailed to applicant approximately three weeks prior to the issue date of the patent, and will include the patent term adjustment on the patent. Any request for reconsideration of the patent term adjustment determination (or reinstatement of patent term adjustment) should follow the process outlined in 37 CFR 1.705.

Any questions regarding the Patent Term Extension or Adjustment determination should be directed to the Office of Patent Legal Administration at (571)-272-7702. Questions relating to issue and publication fee payments should be directed to the Customer Service Center of the Office of Patent Publication at 1-(888)-786-0101 or (571)-272-4200.

OMB Clearance and PRA Burden Statement for PTOL-85 Part B

The Paperwork Reduction Act (PRA) of 1995 requires Federal agencies to obtain Office of Management and Budget approval before requesting most types of information from the public. When OMB approves an agency request to collect information from the public, OMB (i) provides a valid OMB Control Number and expiration date for the agency to display on the instrument that will be used to collect the information and (ii) requires the agency to inform the public about the OMB Control Number's legal significance in accordance with 5 CFR 1320.5(b).

The information collected by PTOL-85 Part B is required by 37 CFR 1.311. The information is required to obtain or retain a benefit by the public which is to file (and by the USPTO to process) an application. Confidentiality is governed by 35 U.S.C. 122 and 37 CFR 1.14. This collection is estimated to take 12 minutes to complete, including gathering, preparing, and submitting the completed application form to the USPTO. Time will vary depending upon the individual case. Any comments on the amount of time you require to complete this form and/or suggestions for reducing this burden, should be sent to the Chief Information Officer, U.S. Patent and Trademark Office, U.S. Department of Commerce, P.O. Box 1450, Alexandria, Virginia 22313-1450. DO NOT SEND FEES OR COMPLETED FORMS TO THIS ADDRESS. SEND TO: Commissioner for Patents, P.O. Box 1450, Alexandria, Virginia 22313-1450. Under the Paperwork Reduction Act of 1995, no persons are required to respond to a collection of information unless it displays a valid OMB control number.

Privacy Act Statement

The Privacy Act of 1974 (P.L. 93-579) requires that you be given certain information in connection with your submission of the attached form related to a patent application or patent. Accordingly, pursuant to the requirements of the Act, please be advised that: (1) the general authority for the collection of this information is 35 U.S.C. 2(b)(2); (2) furnishing of the information solicited is voluntary; and (3) the principal purpose for which the information is used by the U.S. Patent and Trademark Office is to process and/or examine your submission related to a patent application or patent. If you do not furnish the requested information, the U.S. Patent and Trademark Office may not be able to process and/or examine your submission, which may result in termination of proceedings or abandonment of the application or expiration of the patent.

The information provided by you in this form will be subject to the following routine uses:

1. The information on this form will be treated confidentially to the extent allowed under the Freedom of Information Act (5 U.S.C. 552) and the Privacy Act (5 U.S.C. 552a). Records from this system of records may be disclosed to the Department of Justice to determine whether disclosure of these records is required by the Freedom of Information Act.
2. A record from this system of records may be disclosed, as a routine use, in the course of presenting evidence to a court, magistrate, or administrative tribunal, including disclosures to opposing counsel in the course of settlement negotiations.
3. A record in this system of records may be disclosed, as a routine use, to a Member of Congress submitting a request involving an individual, to whom the record pertains, when the individual has requested assistance from the Member with respect to the subject matter of the record.
4. A record in this system of records may be disclosed, as a routine use, to a contractor of the Agency having need for the information in order to perform a contract. Recipients of information shall be required to comply with the requirements of the Privacy Act of 1974, as amended, pursuant to 5 U.S.C. 552a(m).
5. A record related to an International Application filed under the Patent Cooperation Treaty in this system of records may be disclosed, as a routine use, to the International Bureau of the World Intellectual Property Organization, pursuant to the Patent Cooperation Treaty.
6. A record in this system of records may be disclosed, as a routine use, to another federal agency for purposes of National Security review (35 U.S.C. 181) and for review pursuant to the Atomic Energy Act (42 U.S.C. 218(c)).
7. A record from this system of records may be disclosed, as a routine use, to the Administrator, General Services, or his/her designee, during an inspection of records conducted by GSA as part of that agency's responsibility to recommend improvements in records management practices and programs, under authority of 44 U.S.C. 2904 and 2906. Such disclosure shall be made in accordance with the GSA regulations governing inspection of records for this purpose, and any other relevant (i.e., GSA or Commerce) directive. Such disclosure shall not be used to make determinations about individuals.
8. A record from this system of records may be disclosed, as a routine use, to the public after either publication of the application pursuant to 35 U.S.C. 122(b) or issuance of a patent pursuant to 35 U.S.C. 151. Further, a record may be disclosed, subject to the limitations of 37 CFR 1.14, as a routine use, to the public if the record was filed in an application which became abandoned or in which the proceedings were terminated and which application is referenced by either a published application, an application open to public inspection or an issued patent.
9. A record from this system of records may be disclosed, as a routine use, to a Federal, State, or local law enforcement agency, if the USPTO becomes aware of a violation or potential violation of law or regulation.

Notice of Allowability	Application No. 14/485,612	Applicant(s) JANNARD ET AL.	
	Examiner TRUNG DIEP	Art Unit 2664	AIA (First Inventor to File) Status No

-- The MAILING DATE of this communication appears on the cover sheet with the correspondence address--

All claims being allowable, PROSECUTION ON THE MERITS IS (OR REMAINS) CLOSED in this application. If not included herewith (or previously mailed), a Notice of Allowance (PTOL-85) or other appropriate communication will be mailed in due course. **THIS NOTICE OF ALLOWABILITY IS NOT A GRANT OF PATENT RIGHTS.** This application is subject to withdrawal from issue at the initiative of the Office or upon petition by the applicant. See 37 CFR 1.313 and MPEP 1308.

1. This communication is responsive to the RCE filed on 09/29/2015.
 A declaration(s)/affidavit(s) under **37 CFR 1.130(b)** was/were filed on _____.
2. An election was made by the applicant in response to a restriction requirement set forth during the interview on _____; the restriction requirement and election have been incorporated into this action.
3. The allowed claim(s) is/are 1-30. As a result of the allowed claim(s), you may be eligible to benefit from the **Patent Prosecution Highway** program at a participating intellectual property office for the corresponding application. For more information, please see http://www.uspto.gov/patents/init_events/pph/index.jsp or send an inquiry to PPHfeedback@uspto.gov.
4. Acknowledgment is made of a claim for foreign priority under 35 U.S.C. § 119(a)-(d) or (f).

Certified copies:

- a) All b) Some *c) None of the:
1. Certified copies of the priority documents have been received.
 2. Certified copies of the priority documents have been received in Application No. _____.
 3. Copies of the certified copies of the priority documents have been received in this national stage application from the International Bureau (PCT Rule 17.2(a)).
- * Certified copies not received: _____.

Applicant has **THREE MONTHS FROM THE "MAILING DATE"** of this communication to file a reply complying with the requirements noted below. Failure to timely comply will result in **ABANDONMENT** of this application.
THIS THREE-MONTH PERIOD IS NOT EXTENDABLE.

5. **CORRECTED DRAWINGS** (as "replacement sheets") must be submitted.
 including changes required by the attached Examiner's Amendment / Comment or in the Office action of Paper No./Mail Date _____.
Identifying indicia such as the application number (see 37 CFR 1.84(c)) should be written on the drawings in the front (not the back) of each sheet. Replacement sheet(s) should be labeled as such in the header according to 37 CFR 1.121(d).
6. **DEPOSIT OF and/or INFORMATION** about the deposit of **BIOLOGICAL MATERIAL** must be submitted. Note the attached Examiner's comment regarding **REQUIREMENT FOR THE DEPOSIT OF BIOLOGICAL MATERIAL**.

Attachment(s)

- | | |
|--|--|
| 1. <input checked="" type="checkbox"/> Notice of References Cited (PTO-892) | 5. <input type="checkbox"/> Examiner's Amendment/Comment |
| 2. <input checked="" type="checkbox"/> Information Disclosure Statements (PTO/SB/08),
Paper No./Mail Date _____ | 6. <input checked="" type="checkbox"/> Examiner's Statement of Reasons for Allowance |
| 3. <input type="checkbox"/> Examiner's Comment Regarding Requirement for Deposit
of Biological Material | 7. <input type="checkbox"/> Other _____. |
| 4. <input type="checkbox"/> Interview Summary (PTO-413),
Paper No./Mail Date _____. | |

Art Unit: 2664

1. The present application is being examined under the pre-AIA first to invent provisions.

DETAILED ACTION

Continued Examination Under 37 CFR 1.114

2. A request for continued examination under 37 CFR 1.114, including the fee set forth in 37 CFR 1.17(e), was filed in this application after final rejection. Since this application is eligible for continued examination under 37 CFR 1.114, and the fee set forth in 37 CFR 1.17(e) has been timely paid, the finality of the previous Office action has been withdrawn pursuant to 37 CFR 1.114. Applicant's submission filed on 09/29/2015 has been entered.

Terminal Disclaimer

3. The terminal disclaimer filed on 8/03/2015 disclaiming the terminal portion of any patent granted on this application which would extend beyond the expiration date of the full statutory term prior application No. 14/485,611 has been reviewed and is accepted. The terminal disclaimer has been recorded.

Information Disclosure Statement

4. The information disclosure statement (IDS) submitted on 08/05/2015, 05/18/2015 and 09/29/2015 is in compliance with the provisions of 37 CFR 1.97. Accordingly, the information disclosure statement is being considered by the examiner.

Allowable Subject Matter

5. Claims 1-30 are allowed.

Art Unit: 2664

The Examiner's statement of reasons for allowance has been stated in the Applicant remarks filed on 05/18/2015 and supplemental amendments filed on 08/03/2015.

Conclusion

Any inquiry concerning this communication or earlier communications from the examiner should be directed to TRUNG DIEP whose telephone number is (571)270-5088. The examiner can normally be reached on Mon.,- Thur., 8:00 am,-5:00 p.m. EST.

If attempts to reach the examiner by telephone are unsuccessful, the examiner's supervisor, Lin Ye can be reached on (571) 272-7372. The fax phone number for the organization where this application or proceeding is assigned is 571-273-8300.

Information regarding the status of an application may be obtained from the Patent Application Information Retrieval (PAIR) system. Status information for published applications may be obtained from either Private PAIR or Public PAIR. Status information for unpublished applications is available through Private PAIR only. For more information about the PAIR system, see <http://pair-direct.uspto.gov>. Should you have questions on access to the Private PAIR system, contact the Electronic Business Center (EBC) at 866-217-9197 (toll-free). If you would like assistance from a USPTO Customer Service Representative or access to the automated information system, call 800-786-9199 (IN USA OR CANADA) or 571-272-1000.

/TRUNG DIEP/
Primary Examiner, Art Unit 2664

Notice of References Cited	Application/Control No. 14/485,612	Applicant(s)/Patent Under Reexamination JANNARD ET AL.	
	Examiner TRUNG DIEP	Art Unit 2664	Page 1 of 1

U.S. PATENT DOCUMENTS

*	Document Number Country Code-Number-Kind Code	Date MM-YYYY	Name	CPC Classification	US Classification
*	A US-7,898,575 B2	03-2011	Ishii; Kensuke	H04N3/1562	348/222.1
*	B US-8,014,597 B1	09-2011	Newman; David A.	H04N1/648	382/166
C	US-				
D	US-				
E	US-				
F	US-				
G	US-				
H	US-				
I	US-				
J	US-				
K	US-				
L	US-				
M	US-				

FOREIGN PATENT DOCUMENTS

*	Document Number Country Code-Number-Kind Code	Date MM-YYYY	Country	Name	CPC Classification
N					
O					
P					
Q					
R					
S					
T					

NON-PATENT DOCUMENTS

*	Document Number Country Code-Number-Kind Code	Date MM-YYYY	Country	Name	CPC Classification
*	Include as applicable: Author, Title Date, Publisher, Edition or Volume, Pertinent Pages)				
U					
V					
W					
X					

*A copy of this reference is not being furnished with this Office action. (See MPEP § 707.05(a).)
Dates in MM-YYYY format are publication dates. Classifications may be US or foreign.

Search Notes 	Application/Control No. 14485612	Applicant(s)/Patent Under Reexamination JANNARD ET AL.
	Examiner TRUNG DIEP	Art Unit 2664

CPC- SEARCHED		
Symbol	Date	Examiner
(G08B13/19628 OR H04N9/43 OR G06T7/2006 OR H04N9/045 OR H04N2209/046 OR H04N5/23235 OR H04N13/0257 OR G06T3/4015 OR G06T9/007 OR H04N19/00315 OR H04N19/00763 OR H04N19/00903 OR H04N1/648 OR H04N5/225	11/10/2014	TD

CPC COMBINATION SETS - SEARCHED		
Symbol	Date	Examiner

US CLASSIFICATION SEARCHED			
Class	Subclass	Date	Examiner
348	240.2, 222.1, 223.1, 273-280.	11/10/2014	TD
375	240.2, 240.25, 240.26 and 340.29.	11/10/2014	TD
382	166-167.	11/10/2014	TD

SEARCH NOTES		
Search Notes	Date	Examiner
EAST searched.	11/10/2014	TD
Combined text with US subclasses searched.	11/10/2014	TD
Combined text with US subgroups searched.	11/10/2014	TD
Parent case (13/464,803), its continuity and references checked.	11/10/2014	TD
Inventorship searched.	8/6/2015	TD
Copending application double patenting searched.	8/6/2015	TD
Text searched -- See search history.	8/6/2015	TD
IDS searched.	11/24/2015	TD

INTERFERENCE SEARCH			
US Class/ CPC Symbol	US Subclass / CPC Group	Date	Examiner

--	--

INTERFERENCE SEARCH

US Class/ CPC Symbol	US Subclass / CPC Group	Date	Examiner
All	PGPUB text searched.	8/6/2015	TD

--	--

INFORMATION DISCLOSURE STATEMENT

Inventor	: James H. Jannard	11/24/2015
App. No.	: 14/485612	/Trung Diep/
Filed	: September 12, 2014	
For	: VIDEO CAMERA	
Examiner	: Diep, Trung T.	
Art Unit	: 2664	
Conf. No.	: 1068	

Mail Stop RCE

Commissioner for Patents
P.O. Box 1450
Alexandria, VA 22313-1450

References and Listing

Pursuant to 37 CFR 1.56, an Information Disclosure Statement listing references is provided herewith. Pursuant to 37 C.F.R § 1.97(g) and (h), Applicants make no representation that the information is considered to be material to patentability. Additionally, inclusion on this list is not an admission that any of the cited documents are prior art in this application. Further, Applicants make no representation regarding the completeness of this list, or that better art does not exist.

Applicant wishes to draw the Examiner's attention to the following applications owned by of the present application's assignee:

Docket No.	Serial No.	Patent/ Publication No	Title	Filed
REDCOM.007A	12/101,882	8,174,560	VIDEO CAMERA	04/11/2008
REDCOM.007CP1	12/422,507	8,237,830	VIDEO CAMERA	04/13/2009
REDCOM.007CP1C1	12/834,854	7,830,967	VIDEO CAMERA	07/12/2010
REDCOM.007C1	13/464,803	8,872,933	VIDEO CAMERA	05/04/2012
REDCOM.007C2	13/566,868	8,358,357	VIDEO CAMERA	08/03/2012
REDCOM.007CP1C2	13/566,924	8,878,952	VIDEO CAMERA	08/03/2012
REDCOM.007X1 (reexamination REDCOM.007A)	90/012,550	8,174,560 C1	VIDEO CAMERA	09/13/2012

Application No.: 14/485612
Filing Date: September 12, 2014

Docket No.	Serial No.	Patent/ Publication No	Title	Filed
REDCOM.007C3	14/485,611	2015/0003801	VIDEO CAMERA	09/12/2014
REDCOM.007P1C3	14/488,030	9,019,393	VIDEO PROCESSING SYSTEM AND METHOD	09/16/2014
REDCOM.007P1C4	14/609,090	N/A	VIDEO CAMERA	01/29/2015

Applicant notes that cited references, office actions, responses and notices of allowance currently exist or will exist for the above-referenced matters. Applicant also understands that the Examiner has access to sophisticated online Patent Office computing systems that provide ready access to the full file histories of these matters including, for example, specifications, drawings, pending claims, cited art, office actions, responses, declarations, and notices of allowance. Rather than submit copies these file histories, Applicant respectfully requests that the Examiner continue to review these file histories online for past, current, and future information about these matters. Also, if the Examiner cannot readily access these file histories, the Applicant would be pleased to provide any portion of any of the file histories at any time upon specific Examiner request.

No Disclaimers

To the extent that anything in the Information Disclosure Statement or the listed references could be construed as a disclaimer of any subject matter supported by the present application, Applicant hereby rescinds and retracts such disclaimer.

Timing of Disclosure

This Information Disclosure Statement is being filed with an RCE and no fee is believed to be required. The Commissioner is hereby authorized to charge any additional fees which may be required or to credit any overpayment to Account No. 11-1410.

Respectfully submitted,
 KNOBBE, MARTENS, OLSON & BEAR, LLP

Dated: September 29, 2015

By: /Sean Ambrosius/ _____
 Sean Ambrosius
 Registration No. 65,290
 Attorney of Record
 Customer No. 20995
 (949) 760-0404

21657852

EAST Search History

EAST Search History (Prior Art)

Ref #	Hits	Search Query	DBs	Default Operator	Plurals	Time Stamp
S44	0	((video or motion or mov\$3 adj image) and compress\$3 and (raw adj data) and (2K or 4K adj camera)).CLM.	US-PGPUB; USPAT	OR	OFF	2015/08/06 12:15
S45	0	((video or motion or mov\$3 adj image) and compress\$3 and (raw adj data) and (2K or 4K adj camera)).CLM.	US-PGPUB	OR	OFF	2015/08/06 12:16
S46	12	((video or motion or mov\$3 adj image) and compress\$3 and (2K or 4K adj camera)).CLM.	US-PGPUB; USPAT	OR	OFF	2015/08/06 12:17
S47	3	((video or motion or mov\$3 adj image) and compress\$3 and (2K or 4K adj camera)).CLM.	US-PGPUB	OR	OFF	2015/08/06 12:19
S48	0	((2K or 4K adj resolution) and compress\$3 and (raw adj data) and (movie or cinema adj camera)).CLM.	US-PGPUB; USPAT	OR	OFF	2015/08/06 12:21
S49	0	((2K or 4K adj resolution) and compress\$3 and (raw adj data) and (movie or cinema adj camera)).CLM.	US-PGPUB	OR	OFF	2015/08/06 12:21
S50	0	((video or motion or mov\$3 adj image) and (mathematica\$3 adj compress\$3) and (raw adj data) and (2K or 4K adj camera)).CLM.	US-PGPUB; USPAT	OR	OFF	2015/08/06 12:22
S51	0	((video or motion or mov\$3 adj image) and (mathematica\$3 adj compress\$3) and (raw adj data) and (2K or 4K adj camera)).CLM.	US-PGPUB	OR	OFF	2015/08/06 12:22
S52	0	((video or motion or mov\$3 adj image) and compress\$3 and (raw adj data) and (2K or 4K adj resolution)).CLM.	US-PGPUB; USPAT	OR	OFF	2015/08/06 12:26
S53	0	((video or motion or mov\$3 adj image) and compress\$3 and (raw adj data) and (2K or 4K adj resolution)).CLM.	US-PGPUB	OR	OFF	2015/08/06 12:26
S54	1	((video or motion or mov\$3 adj image) and (raw adj data) and (2K or 4K adj resolution)).CLM.	US-PGPUB; USPAT	OR	OFF	2015/08/06 12:27
S55	1	((video or motion or mov\$3 adj image) and (raw adj data) and (2K or 4K adj resolution)).CLM.	US-PGPUB	OR	OFF	2015/08/06 12:28
S56	320	((James) near2 (Jannard)).INV.	US-PGPUB; USPAT; USOCR	OR	OFF	2015/08/06 12:28
S57	2	"7480417".pn.	US-PGPUB; USPAT; USOCR; FPRS;	OR	ON	2015/11/24 14:19

			EPO; JPO; DERWENT; IBM_TDB			
S58	0	S57 and (2K or 4K adj camera)	US-PGPUB; USPAT; USOCR; FPRS; EPO; JPO; DERWENT; IBM_TDB	OR	ON	2015/11/24 14:21
S59	3	"20080259180"	US-PGPUB; USPAT; USOCR; FPRS; EPO; JPO; DERWENT; IBM_TDB	OR	ON	2015/11/24 14:27
S60	0	S59 and (2K or 4K adj camera)	US-PGPUB; USPAT; USOCR; FPRS; EPO; JPO; DERWENT; IBM_TDB	OR	ON	2015/11/24 14:27
S61	2	"20100265367"	US-PGPUB; USPAT; USOCR; FPRS; EPO; JPO; DERWENT; IBM_TDB	OR	ON	2015/11/24 14:28
S62	3	"20060158704"	US-PGPUB; USPAT; USOCR; FPRS; EPO; JPO; DERWENT; IBM_TDB	OR	ON	2015/11/24 14:29
S63	7	"20060012694"	US-PGPUB; USPAT; USOCR; FPRS; EPO; JPO; DERWENT; IBM_TDB	OR	ON	2015/11/24 14:30
S64	3	"20020196354"	US-PGPUB; USPAT; USOCR; FPRS; EPO; JPO; DERWENT; IBM_TDB	OR	ON	2015/11/24 14:31
S65	14	"20060007324"	US-PGPUB; USPAT; USOCR; FPRS; EPO; JPO; DERWENT; IBM_TDB	OR	ON	2015/11/24 14:31

11/24/2015 3:17:59 PM

C:\Users\tdiep\Documents\EAST\Workspaces\14485612.wsp



UNITED STATES PATENT AND TRADEMARK OFFICE

UNITED STATES DEPARTMENT OF COMMERCE
 United States Patent and Trademark Office
 Address: COMMISSIONER FOR PATENTS
 P.O. Box 1450
 Alexandria, Virginia 22313-1450
 www.uspto.gov

BIB DATA SHEET

CONFIRMATION NO. 1068

SERIAL NUMBER 14/485,612	FILING or 371(c) DATE 09/12/2014 RULE	CLASS 348	GROUP ART UNIT 2664	ATTORNEY DOCKET NO. REDCOM.007C4	
APPLICANTS RED.COM, INC., Irvine, CA; INVENTORS James H. Jannard, Las Vegas, NV; Thomas Graeme Nattress, Acton, CANADA; ** CONTINUING DATA ***** This application is a CON of 13/464,803 05/04/2012 PAT 8872933 which is a CON of 12/101,882 04/11/2008 PAT 8174560 which claims benefit of 60/911,196 04/11/2007 and claims benefit of 61/017,406 12/28/2007 ** FOREIGN APPLICATIONS ***** ** IF REQUIRED, FOREIGN FILING LICENSE GRANTED ** 09/18/2014					
Foreign Priority claimed <input type="checkbox"/> Yes <input checked="" type="checkbox"/> No 35 USC 119(a-d) conditions met <input type="checkbox"/> Yes <input checked="" type="checkbox"/> No Verified and Acknowledged <u>TRUNG T DIEP/</u> Examiner's Signature	<input type="checkbox"/> Met after Allowance Initials	STATE OR COUNTRY NV	SHEETS DRAWINGS 18	TOTAL CLAIMS 30	INDEPENDENT CLAIMS 2
ADDRESS KNOBBE MARTENS OLSON & BEAR LLP 2040 MAIN STREET FOURTEENTH FLOOR IRVINE, CA 92614 UNITED STATES					
TITLE VIDEO CAMERA					
FILING FEE RECEIVED 2540	FEES: Authority has been given in Paper No. _____ to charge/credit DEPOSIT ACCOUNT No. _____ for following:		<input type="checkbox"/> All Fees <input type="checkbox"/> 1.16 Fees (Filing) <input type="checkbox"/> 1.17 Fees (Processing Ext. of time) <input type="checkbox"/> 1.18 Fees (Issue) <input type="checkbox"/> Other _____ <input type="checkbox"/> Credit		

INFORMATION DISCLOSURE STATEMENT BY APPLICANT	Application No.	14/485612	
	Filing Date	September 12, 2014	
	First Named Inventor	James H. Jannard	
	Art Unit	2664	
<i>(Multiple sheets used when necessary)</i>		Examiner	Diep, Trung T.
SHEET 1 OF 2		Attorney Docket No.	REDCOM.007C4

U.S. PATENT DOCUMENTS					
Examiner Initials	Cite No.	Document Number <i>Number - Kind Code (if known)</i> Example: 1,234,567 B1	Publication Date MM-DD-YYYY	Name	Pages, Columns, Lines Where Relevant Passages or Relevant Figures Appear
/T.D./	1	5,132,803	07-21-1992	Suga et al.	
/T.D./	2	5,172,227	12-15-1992	Tsai et al.	
/T.D./	3	5,412,427	05-02-1995	Rabbani et al.	
/T.D./	4	6,169,317	01-02-2001	Sawada et al.	
/T.D./	5	6,878,977	04-12-2005	Kozuka et al.	
	6	7,902,512	03-08-2011	Chang et al.	
/T.D./	7	7,952,636	05-31-2011	Ikeda et al.	
/T.D./	8	8,125,547	02-28-2012	Oda et al.	
/T.D./	9	8,477,173	07-02-2013	Kenoyer	
/T.D./	10	8,792,029	07-29-2014	Lee	
/T.D./	11	8,817,141	08-26-2014	Tanaka	
/T.D./	12	8,872,933 (and entire prosecution history) (REDCOM.007C1)	10-28-2014	Jannard et al.	
/T.D./	13	8,878,952 (and entire prosecution history) (REDCOM.007CP1C2)	11-04-2014	Jannard et al.	
/T.D./	14	9,019,393 (and entire prosecution history) (REDCOM.007P1C3)	04-28-2015	Jannard et al.	
/T.D./	15	2001/0048477	12-06-2001	Misawa	
/T.D./	16	2002/0039142	04-04-2002	Zhang et al.	
/T.D./	17	2002/0167602	11-14-2002	Nguyen	
/T.D./	18	2004/0201760	10-14-2004	Ota et al.	
/T.D./	19	2005/0041116	02-24-2005	Tsukioka	
/T.D./	20	2007/0133902	06-14-2007	Kumar	
/T.D./	21	2007/0164335	07-19-2007	McKee	
/T.D./	22	2008/0012953	01-17-2008	Yang et al.	
/T.D./	23	2008/0063269	03-13-2008	Chiu	
/T.D./	24	2008/0285871	11-20-2008	Ishikawa	
/T.D./	25	2009/0033752	02-05-2009	Bodnar et al.	
/T.D./	26	2009/0086817	04-02-2009	Matsuoka et al.	

Examiner Signature	/Trung Diep/	Date Considered	11/24/2015
--------------------	--------------	-----------------	------------

***Examiner:** Initial if reference considered, whether or not citation is in conformance with MPEP 609. Draw line through citation if not in conformance and not considered. Include copy of this form with next communication to applicant.

T¹ - Place a check mark in this area when an English language Translation is attached.

INFORMATION DISCLOSURE STATEMENT BY APPLICANT	Application No.	14/485612
	Filing Date	September 12, 2014
	First Named Inventor	James H. Jannard
	Art Unit	2664
<i>(Multiple sheets used when necessary)</i>	Examiner	Diep, Trung T.
SHEET 2 OF 2	Attorney Docket No.	REDCOM.007C4

U.S. PATENT DOCUMENTS					
Examiner Initials	Cite No.	Document Number <i>Number - Kind Code (if known)</i> Example: 1,234,567 B1	Publication Date MM-DD-YYYY	Name	Pages, Columns, Lines Where Relevant Passages or Relevant Figures Appear
/T.D./	27	2010/0225795	09-09-2010	Suzuki et al.	
/T.D./	28	2011/0194763	08-11-2011	Moon et al.	
/T.D./	29	2014/0063297	03-06-2014	Yamura	
/T.D./	30	2014/0161367	06-12-2014	Ridenour et al.	
/T.D./	31	2014/0218580	08-07-2014	Mayer et al.	
/T.D./	32	2014/0333810	11-13-2014	Nakaseko	
/T.D./	33	2015/0003801 (and entire prosecution history) (REDCOM.007C3)	01-01-2015	Jannard et al.	
/T.D./	34	2015/0092094	04-02-2015	Itonaga et al.	

FOREIGN PATENT DOCUMENTS						
Examiner Initials	Cite No.	Foreign Patent Document <i>Country Code-Number-Kind Code</i> Example: JP 1234567 A1	Publication Date MM-DD-YYYY	Name	Pages, Columns, Lines Where Relevant Passages or Relevant Figures Appear	T ¹
/T.D./	35	CA 2 831 698	10-23-2008	Red.com, Inc.		
/T.D./	36	CN 101689357	03-04-2015	Red.com, Inc.		X
/T.D./	37	JP 2008-124976	05-29-2008	Fujitsu Ltd.		X
/T.D./	38	KR 10-1478380	12-24-2014	Red.com, Inc.		X
/T.D./	39	WO 99/012345	03-11-1999	Intel Corporation		

NON PATENT LITERATURE DOCUMENTS			
Examiner Initials	Cite No.	Include name of the author (in CAPITAL LETTERS), title of the article (when appropriate), title of the item (book, magazine, journal, serial, symposium, catalog, etc.), date, page(s), volume-issue number(s), publisher, city and/or country where published.	T ¹
/T.D./	40	Notice of Opposition in European Application No. 08745686.9 (REDCOM.007VEP), dated April 22, 2015.	
	41	Official Communication in Korean Application No. 10-2014-7021892 (REDCOM.007VKRD1), dated October 10, 2014.	X

20660190

Examiner Signature	/Trung Diep/	Date Considered	11/24/2015
--------------------	--------------	-----------------	------------

***Examiner:** Initial if reference considered, whether or not citation is in conformance with MPEP 609. Draw line through citation if not in conformance and not considered. Include copy of this form with next communication to applicant.

T¹ - Place a check mark in this area when an English language Translation is attached.

INFORMATION DISCLOSURE STATEMENT

Inventor	: James H. Jannard
App. No.	: 14/485612
Filed	: September 12, 2014
For	: VIDEO CAMERA
Examiner	: Diep, Trung T.
Art Unit	: 2664
Conf. No.	: 1068

/Trung Diep/
11/24/2015

Mail Stop Amendment
Commissioner for Patents
P.O. Box 1450
Alexandria, VA 22313-1450

References and Listing

Pursuant to 37 CFR 1.56, an Information Disclosure Statement listing references is provided herewith.

In particular, submitted Reference No. 1 is an Official Communication in Korean Patent Application No. 10-2014-7021892, along with a partial English language translation, in four total pages. To the best of the knowledge of the undersigned, the translation includes a partial translation of page 1 of the Official Communication and a complete translation of page 2 of the Official Communication. No representation is made as to the accuracy of the translation.

If the Examiner would like additional information regarding these references or if anything is unclear, the Examiner is invited to contact the undersigned for assistance.

Pursuant to 37 C.F.R § 1.97(g) and (h), Applicants make no representation that the information is considered to be material to patentability. Additionally, inclusion on this list is not an admission that any of the cited documents are prior art in this application. Further, Applicants make no representation regarding the completeness of this list, or that better art does not exist.

Applicant wishes to draw the Examiner's attention to the following applications owned by of the present application's assignee:

Docket No.	Serial No.	Patent/ Publication No	Title	Filed
REDCOM.007A	12/101,882	8,174,560	VIDEO CAMERA	04/11/2008

Application No.: 14/485612
Filing Date: September 12, 2014

Docket No.	Serial No.	Patent/ Publication No	Title	Filed
REDCOM.007CP1	12/422,507	8,237,830	VIDEO CAMERA	04/13/2009
REDCOM.007CP1C1	12/834,854	7,830,967	VIDEO CAMERA	07/12/2010
REDCOM.007C1	13/464,803	8,872,933	VIDEO CAMERA	05/04/2012
REDCOM.007C2	13/566,868	8,358,357	VIDEO CAMERA	08/03/2012
REDCOM.007CP1C2	13/566,924	8,878,952	VIDEO CAMERA	08/03/2012
REDCOM.007X1 (reexamination REDCOM.007A)	90/012,550	8,174,560 C1	VIDEO CAMERA	09/13/2012
REDCOM.007C3	14/485,611	2015/0003801	VIDEO CAMERA	09/12/2014
REDCOM.007P1C3	14/488,030	9,019,393	VIDEO PROCESSING SYSTEM AND METHOD	09/16/2014
REDCOM.007P1C4	14/609,090	N/A	VIDEO CAMERA	01/29/2015

Applicant notes that cited references, office actions, responses and notices of allowance currently exist or will exist for the above-referenced matters. Applicant also understands that the Examiner has access to sophisticated online Patent Office computing systems that provide ready access to the full file histories of these matters including, for example, specifications, drawings, pending claims, cited art, office actions, responses, declarations, and notices of allowance. Rather than submit copies these file histories, Applicant respectfully requests that the Examiner continue to review these file histories online for past, current, and future information about these matters. Also, if the Examiner cannot readily access these file histories, the Applicant would be pleased to provide any portion of any of the file histories at any time upon specific Examiner request.

No Disclaimers

To the extent that anything in the Information Disclosure Statement or the listed references could be construed as a disclaimer of any subject matter supported by the present application, Applicant hereby rescinds and retracts such disclaimer.

Timing of Disclosure

This Information Disclosure Statement is being filed after receipt of a First Office Action, but before the mailing date of a Final Action and before the mailing date of a Notice of Allowance. This Statement is accompanied by the fees set forth in 37 CFR 1.17(p). The

Application No.: 14/485612
Filing Date: September 12, 2014

Commissioner is hereby authorized to charge any additional fees which may be required or to credit any overpayment to Account No. 11-1410.

Respectfully submitted,
KNOBBE, MARTENS, OLSON & BEAR, LLP

Dated: August 5, 2015

By: /Sean Ambrosius/ _____
Sean Ambrosius
Registration No. 65,290
Attorney of Record
Customer No. 20995
(949) 760-0404

20660934

INFORMATION DISCLOSURE STATEMENT BY APPLICANT	Application No.	14/485612
	Filing Date	September 12, 2014
	First Named Inventor	James H. Jannard
	Art Unit	2664
<i>(Multiple sheets used when necessary)</i>	Examiner	Diep, Trung T.
SHEET 1 OF 1	Attorney Docket No.	REDCOM.007C4

U.S. PATENT DOCUMENTS					
Examiner Initials	Cite No.	Document Number <i>Number - Kind Code (if known)</i> Example: 1,234,567 B1	Publication Date MM-DD-YYYY	Name	Pages, Columns, Lines Where Relevant Passages or Relevant Figures Appear
/T.D./	1	7,480,417	01-20-2009	Malvar	

FOREIGN PATENT DOCUMENTS						
Examiner Initials	Cite No.	Foreign Patent Document <i>Country Code-Number-Kind Code</i> Example: JP 1234567 A1	Publication Date MM-DD-YYYY	Name	Pages, Columns, Lines Where Relevant Passages or Relevant Figures Appear	T ¹
/T.D./	2	CN 104702926	06-10-2015	Red.com, Inc.		X

NON PATENT LITERATURE DOCUMENTS			
Examiner Initials	Cite No.	Include name of the author (in CAPITAL LETTERS), title of the article (when appropriate), title of the item (book, magazine, journal, serial, symposium, catalog, etc.), date, page(s), volume-issue number(s), publisher, city and/or country where published.	T ¹
/T.D./	3	Official Communication in European Application No. 14177071.9 (REDCOM.007VEPD1), dated July 30, 2015.	
/T.D./	4	Examination Report in New Zealand Application No. 710813 (REDCOM.007NZD3), dated August 12, 2015.	
/T.D./	5	Official Communication in Taiwanese Application No. 99111497 (REDCOM.007QTW), dated July 24, 2015.	X
/T.D./	6	International Preliminary Report on Patentability and Written Opinion in PCT Application No. PCT/US2014/016301 (REDCOM.084WO), dated August 27, 2015.	

21659542

Examiner Signature	/Trung Diep/	Date Considered	11/24/2015
<p>*Examiner: Initial if reference considered, whether or not citation is in conformance with MPEP 609. Draw line through citation if not in conformance and not considered. Include copy of this form with next communication to applicant.</p>			

T¹ - Place a check mark in this area when an English language Translation is attached.

Issue Classification 	Application/Control No. 14485612	Applicant(s)/Patent Under Reexamination JANNARD ET AL.
	Examiner TRUNG DIEP	Art Unit 2664

CPC						
Symbol					Type	Version
G06T		3		4015	F	2013-01-01
H04N		1		648	I	2013-01-01
H04N		9		045	I	2013-01-01
H04N		19		186	I	2014-11-01
H04N		19		85	I	2014-11-01
G11B		27		031	I	2013-01-01
H04N		5		2252	I	2013-01-01
H04N		5		374	I	2013-01-01
H04N		5		772	I	2013-01-01
H04N		19		91	I	2014-11-01

CPC Combination Sets				
Symbol	Type	Set	Ranking	Version

NONE		Total Claims Allowed:	
(Assistant Examiner)	(Date)	30	
/TRUNG DIEP/ Primary Examiner. Art Unit 2664	11/24/2015	O.G. Print Claim(s)	O.G. Print Figure
(Primary Examiner)	(Date)	1	8

Issue Classification 	Application/Control No. 14485612	Applicant(s)/Patent Under Reexamination JANNARD ET AL.
	Examiner TRUNG DIEP	Art Unit 2664

US ORIGINAL CLASSIFICATION				INTERNATIONAL CLASSIFICATION							
CLASS		SUBCLASS		CLAIMED				NON-CLAIMED			
348		222.1		H	0	4	N	5 / 228 (2006.0)			
CROSS REFERENCE(S)				H	0	4	N	9 / 73 (2006.0)			
				G	0	6	K	9 / 36 (2006.0)			
CLASS	SUBCLASS (ONE SUBCLASS PER BLOCK)										
348	223.1										
382	166										

NONE			Total Claims Allowed:	
(Assistant Examiner)	(Date)	30		
/TRUNG DIEP/ Primary Examiner. Art Unit 2664	11/24/2015	O.G. Print Claim(s)	O.G. Print Figure	
(Primary Examiner)	(Date)	1	8	

Issue Classification 	Application/Control No. 14485612	Applicant(s)/Patent Under Reexamination JANNARD ET AL.
	Examiner TRUNG DIEP	Art Unit 2664

<input checked="" type="checkbox"/> Claims renumbered in the same order as presented by applicant <input type="checkbox"/> CPA <input checked="" type="checkbox"/> T.D. <input type="checkbox"/> R.1.47															
Final	Original	Final	Original	Final	Original	Final	Original	Final	Original	Final	Original	Final	Original	Final	Original
	1		17												
	2		18												
	3		19												
	4		20												
	5		21												
	6		22												
	7		23												
	8		24												
	9		25												
	10		26												
	11		27												
	12		28												
	13		29												
	14		30												
	15														
	16														

NONE		Total Claims Allowed:	
		30	
(Assistant Examiner)	(Date)	O.G. Print Claim(s)	O.G. Print Figure
/TRUNG DIEP/ Primary Examiner. Art Unit 2664	11/24/2015	1	8
(Primary Examiner)	(Date)		

PART B - FEE(S) TRANSMITTAL

Complete and send this form, together with applicable fee(s), to: **Mail** Mail Stop ISSUE FEE
Commissioner for Patents
P.O. Box 1450
Alexandria, Virginia 22313-1450
or Fax (571)-273-2885

INSTRUCTIONS: This form should be used for transmitting the ISSUE FEE and PUBLICATION FEE (if required). Blocks 1 through 5 should be completed where appropriate. All further correspondence including the Patent, advance orders and notification of maintenance fees will be mailed to the current correspondence address as indicated unless corrected below or directed otherwise in Block 1, by (a) specifying a new correspondence address; and/or (b) indicating a separate "FEE ADDRESS" for maintenance fee notifications.

Note: A certificate of mailing can only be used for domestic mailings of the Fee(s) Transmittal. This certificate cannot be used for any other accompanying papers. Each additional paper, such as an assignment or formal drawing, must have its own certificate of mailing or transmission.

CURRENT CORRESPONDENCE ADDRESS (Note: Use Block 1 for any change of address)

20995 7590 12/10/2015
KNOBBE MARTENS OLSON & BEAR LLP
2040 MAIN STREET
FOURTEENTH FLOOR
IRVINE, CA 92614

Certificate of Mailing or Transmission
 I hereby certify that this Fee(s) Transmittal is being deposited with the United States Postal Service with sufficient postage for first class mail in an envelope addressed to the Mail Stop ISSUE FEE address above, or being facsimile transmitted to the USPTO (571) 273-2885, on the date indicated below.

(Depositor's name)
(Signature)
(Date)

APPLICATION NO.	FILING DATE	FIRST NAMED INVENTOR	ATTORNEY DOCKET NO.	CONFIRMATION NO.
14/485,612	09/12/2014	James H. Jannard	REDCOM.007C4	1068

TITLE OF INVENTION: VIDEO CAMERA

APPLN. TYPE	ENTITY STATUS	ISSUE FEE DUE	PUBLICATION FEE DUE	PREV. PAID ISSUE FEE	TOTAL FEE(S) DUE	DATE DUE
nonprovisional	UNDISCOUNTED	\$960	\$0	\$0	\$960	03/10/2016

EXAMINER	ART UNIT	CLASS-SUBCLASS
DIEP, TRUNG T	2664	348-014000

1. Change of correspondence address or indication of "Fee Address" (37 CFR 1.363).
 Change of correspondence address (or Change of Correspondence Address Form PTO/SB/122) attached.
 "Fee Address" indication (or "Fee Address" Indication form PTO/SB/47; Rev 03-02 or more recent) attached. **Use of a Customer Number is required.**

2. For printing on the patent front page, list
 (1) The names of up to 3 registered patent attorneys or agents OR, alternatively,
 (2) The name of a single firm (having as a member a registered attorney or agent) and the names of up to 2 registered patent attorneys or agents. If no name is listed, no name will be printed.

1. Knobbe, Martens,
 2. Olson & Bear LLP
 3. _____

3. ASSIGNEE NAME AND RESIDENCE DATA TO BE PRINTED ON THE PATENT (print or type)
 PLEASE NOTE: Unless an assignee is identified below, no assignee data will appear on the patent. If an assignee is identified below, the document has been filed for recordation as set forth in 37 CFR 3.11. Completion of this form is NOT a substitute for filing an assignment.

(A) NAME OF ASSIGNEE: RED.COM, Inc. (B) RESIDENCE: (CITY and STATE OR COUNTRY) Irvine, CA

Please check the appropriate assignee category or categories (will not be printed on the patent): Individual Corporation or other private group entity Government

4a. The following fee(s) are submitted:
 Issue Fee
 Publication Fee (No small entity discount permitted)
 Advance Order - # of Copies _____

4b. Payment of Fee(s): (Please first reapply any previously paid issue fee shown above)
 A check is enclosed.
 Payment by credit card. Form PTO-2038 is attached.
 The director is hereby authorized to charge the required fee(s), any deficiency, or credits any overpayment, to Deposit Account Number 11-1410 (enclose an extra copy of this form).

5. Change in Entity Status (from status indicated above)
 Applicant certifying micro entity status. See 37 CFR 1.29
 Applicant asserting small entity status. See 37 CFR 1.27
 Applicant changing to regular undiscounted fee status.

NOTE: Absent a valid certification of Micro Entity Status (see forms PTO/SB/15A and 15B), issue fee payment in the micro entity amount will not be accepted at the risk of application abandonment.
 NOTE: If the application was previously under micro entity status, checking this box will be taken to be a notification of loss of entitlement to micro entity status.
 NOTE: Checking this box will be taken to be a notification of loss of entitlement to small or micro entity status, as applicable.

NOTE: This form must be signed in accordance with 37 CFR 1.31 and 1.33. See 37 CFR 1.4 for signature requirements and certifications.

Authorized Signature Sean Ambrosius Date 12/15/2015
 Typed or printed name Sean Ambrosius Registration No. 65,290

Electronic Patent Application Fee Transmittal

Application Number:	14485612
Filing Date:	12-Sep-2014
Title of Invention:	VIDEO CAMERA
First Named Inventor/Applicant Name:	James H. Jannard
Filer:	Sean Patrick Ambrosius/Daniella Kellogg
Attorney Docket Number:	REDCOM.007C4

Filed as Large Entity

Filing Fees for Utility under 35 USC 111(a)

Description	Fee Code	Quantity	Amount	Sub-Total in USD(\$)
Basic Filing:				
Pages:				
Claims:				
Miscellaneous-Filing:				
Petition:				
Patent-Appeals-and-Interference:				
Post-Allowance-and-Post-Issuance:				
Utility Appl Issue Fee	1501	1	960	960

Description	Fee Code	Quantity	Amount	Sub-Total in USD(\$)
Extension-of-Time:				
Miscellaneous:				
Total in USD (\$)				960

Electronic Acknowledgement Receipt

EFS ID:	24393106
Application Number:	14485612
International Application Number:	
Confirmation Number:	1068
Title of Invention:	VIDEO CAMERA
First Named Inventor/Applicant Name:	James H. Jannard
Customer Number:	20995
Filer:	Sean Patrick Ambrosius/ThuyQuyen Nguyen
Filer Authorized By:	Sean Patrick Ambrosius
Attorney Docket Number:	REDCOM.007C4
Receipt Date:	17-DEC-2015
Filing Date:	12-SEP-2014
Time Stamp:	17:19:01
Application Type:	Utility under 35 USC 111(a)

Payment information:

Submitted with Payment	yes
Payment Type	Credit Card
Payment was successfully received in RAM	\$960
RAM confirmation Number	4384
Deposit Account	111410
Authorized User	KNOBBE MARTENS OLSON AND BEAR

The Director of the USPTO is hereby authorized to charge indicated fees and credit any overpayment as follows:

Charge any Additional Fees required under 37 C.F.R. Section 1.16 (National application filing, search, and examination fees)

Charge any Additional Fees required under 37 C.F.R. Section 1.17 (Patent application and reexamination processing fees)

--	--	--	--	--	--

File Listing:

Document Number	Document Description	File Name	File Size(Bytes)/ Message Digest	Multi Part /.zip	Pages (if appl.)
1	Issue Fee Payment (PTO-85B)	IFEE_REDCOM-007C4.pdf	95041	no	1
			16e7ba9f35f3b5e48e1c45a4627a356eb67ddc40		

Warnings:

Information:

2	Fee Worksheet (SB06)	fee-info.pdf	30480	no	2
			dadc39d5532ae6e3c274db051efcaf9f186593a		

Warnings:

Information:

Total Files Size (in bytes):	125521
-------------------------------------	--------

This Acknowledgement Receipt evidences receipt on the noted date by the USPTO of the indicated documents, characterized by the applicant, and including page counts, where applicable. It serves as evidence of receipt similar to a Post Card, as described in MPEP 503.

New Applications Under 35 U.S.C. 111

If a new application is being filed and the application includes the necessary components for a filing date (see 37 CFR 1.53(b)-(d) and MPEP 506), a Filing Receipt (37 CFR 1.54) will be issued in due course and the date shown on this Acknowledgement Receipt will establish the filing date of the application.

National Stage of an International Application under 35 U.S.C. 371

If a timely submission to enter the national stage of an international application is compliant with the conditions of 35 U.S.C. 371 and other applicable requirements a Form PCT/DO/EO/903 indicating acceptance of the application as a national stage submission under 35 U.S.C. 371 will be issued in addition to the Filing Receipt, in due course.

New International Application Filed with the USPTO as a Receiving Office

If a new international application is being filed and the international application includes the necessary components for an international filing date (see PCT Article 11 and MPEP 1810), a Notification of the International Application Number and of the International Filing Date (Form PCT/RO/105) will be issued in due course, subject to prescriptions concerning national security, and the date shown on this Acknowledgement Receipt will establish the international filing date of the application.

INFORMATION DISCLOSURE STATEMENT BY APPLICANT	Application No.	14/485612	
	Filing Date	September 12, 2014	
	First Named Inventor	James H. Jannard	
	Art Unit	2661	
<i>(Multiple sheets used when necessary)</i>		Examiner	Unknown
SHEET 4 OF 14		Attorney Docket No.	REDCOM.007C4

U.S. PATENT DOCUMENTS					
Examiner Initials	Cite No.	Document Number <i>Number - Kind Code (if known)</i> Example: 1,234,567 B1	Publication Date MM-DD-YYYY	Name of Patentee or Applicant	Pages, Columns, Lines Where Relevant Passages or Relevant Figures Appear
	87	7,907,791	03-15-2011	Kinrot	
	88	7,936,919	05-03-2011	Kameyama	
	89	8,014,597	09-06-2011	Newman	
Change(s) applied to document, /C.C.B./ 8/26/2015	90	8,174,560 C1 (and entire prosecution history) (REDCOM.007A)	05-16-2014	Jannard et al.	05/2012
	91	8,237,830 (and entire prosecution history) (REDCOM.007CP1)	08-07-2012	Jannard et al.	
	92	8,358,357 (and entire prosecution history) (REDCOM.007C2)	01-22-2013	Jannard et al.	
	93	RE 37,342	08-02-2001	Washino et al.	
	94	RE 38,079	04-15-2003	Washino et al.	
	95	2002/0041707	04-11-2002	Newman	
	96	2002/0063787	05-30-2002	Watanabe	
	97	2002/0196354	12-26-2002	Chang et al.	
	98	2003/0007567	01-09-2003	Newman et al.	
	99	2003/0011747	01-16-2003	Lenz	
	100	2003/0018750	01-23-2003	Onno et al.	
	101	2003/0038885	02-27-2003	Rodriguez	
	102	2003/0122037	07-03-2003	Hyde et al.	
	103	2003/0122937	07-03-2003	Guarnera et al.	
	104	2003/0156188	08-21-2003	Abrams Jr.	
	105	2003/0185302	10-02-2003	Abrams Jr.	
	106	2003/0202106	10-30-2003	Kanleinsberger et al.	
	107	2004/0051793	03-18-2004	Tecu	
	108	2004/0095477	05-20-2004	Maki et al.	
	109	2004/0131274	07-08-2004	Perlmutter et al.	
	110	2004/0165080	08-26-2004	Burks et al.	
	111	2004/0169746	09-02-2004	Chen et al.	
	112	2004/0169751	09-02-2004	Takemura et al.	
	113	2004/0196389	10-07-2004	Honda	

Examiner Signature	/Trung Diep/	Date Considered	11/10/2014
--------------------	--------------	-----------------	------------

***Examiner:** Initial if reference considered, whether or not citation is in conformance with MPEP 609. Draw line through citation if not in conformance and not considered. Include copy of this form with next communication to applicant.

T¹ - Place a check mark in this area when an English language translation is attached. ALL REFERENCES CONSIDERED EXCEPT WHERE LINED THROUGH. /T.D./



UNITED STATES PATENT AND TRADEMARK OFFICE

UNITED STATES DEPARTMENT OF COMMERCE
United States Patent and Trademark Office
Address: COMMISSIONER FOR PATENTS
P.O. Box 1450
Alexandria, Virginia 22313-1450
www.uspto.gov

Table with 5 columns: APPLICATION NO., FILING DATE, FIRST NAMED INVENTOR, ATTORNEY DOCKET NO., CONFIRMATION NO.
14/485,612 09/12/2014 James H. Jannard REDCOM.007C4 1068

20995 7590 01/04/2016
KNOBBE MARTENS OLSON & BEAR LLP
2040 MAIN STREET
FOURTEENTH FLOOR
IRVINE, CA 92614

EXAMINER

DIEP, TRUNG T

ART UNIT PAPER NUMBER

2664

NOTIFICATION DATE DELIVERY MODE

01/04/2016

ELECTRONIC

Please find below and/or attached an Office communication concerning this application or proceeding.

The time period for reply, if any, is set in the attached communication.

Notice of the Office communication was sent electronically on above-indicated "Notification Date" to the following e-mail address(es):

jayna.cartee@knobbe.com
efiling@knobbe.com



UNITED STATES DEPARTMENT OF COMMERCE

U.S. Patent and Trademark Office

Address : COMMISSIONER FOR PATENTS
P.O. Box 1450
Alexandria, Virginia 22313-1450

APPLICATION NO./ CONTROL NO.	FILING DATE	FIRST NAMED INVENTOR / PATENT IN REEXAMINATION	ATTORNEY DOCKET NO.
14/485,612	12 September, 2014	JANNARD ET AL.	REDCOM.007C4

KNOBBE MARTENS OLSON & BEAR LLP 2040 MAIN STREET FOURTEENTH FLOOR IRVINE, CA 92614	EXAMINER	
	TRUNG DIEP	
	ART UNIT	PAPER
	2664	20151228

DATE MAILED:

Please find below and/or attached an Office communication concerning this application or proceeding.

Commissioner for Patents

To whom it may concern,
 The Information Disclosure Statement (IDS) filed on 11/24/2015 has been considered and attached. Please contact the Examiner for additional information.
 Thanks,
 Trung Diep

/TRUNG DIEP/
 Primary Examiner, Art Unit 2664

INFORMATION DISCLOSURE STATEMENT BY APPLICANT	Application No.	14/485612
	Filing Date	September 12, 2014
	First Named Inventor	James H. Jannard
	Art Unit	2664
<i>(Multiple sheets used when necessary)</i>	Examiner	Diep, Trung T.
SHEET 1 OF 1	Attorney Docket No.	REDCOM.007C4

U.S. PATENT DOCUMENTS					
Examiner Initials	Cite No.	Document Number <i>Number - Kind Code (if known)</i> Example: 1,234,567 B1	Publication Date MM-DD-YYYY	Name	Pages, Columns, Lines Where Relevant Passages or Relevant Figures Appear
	1	2004/0032516	02-19-2004	Kakarala	
/T.D./	2	U.S. Patent Application No. 14/609090 as filed January 29, 2015 (and entire prosecution history) (REDCOM.007P1C4)	N/A	Jannard et al.	

FOREIGN PATENT DOCUMENTS						
Examiner Initials	Cite No.	Foreign Patent Document <i>Country Code-Number-Kind Code</i> Example: JP 1234567 A1	Publication Date MM-DD-YYYY	Name	Pages, Columns, Lines Where Relevant Passages or Relevant Figures Appear	T ¹
/T.D./	3	WO 2014/127153 (REDCOM.084WO)	08-21-2014	Red.com, Inc.		

NON PATENT LITERATURE DOCUMENTS			
Examiner Initials	Cite No.	Include name of the author (in CAPITAL LETTERS), title of the article (when appropriate), title of the item (book, magazine, journal, serial, symposium, catalog, etc.), date, page(s), volume-issue number(s), publisher, city and/or country where published.	T ¹

22140438

Examiner Signature	/Trung Diep/	Date Considered	12/28/2015
<p>*Examiner: Initial if reference considered, whether or not citation is in conformance with MPEP 609. Draw line through citation if not in conformance and not considered. Include copy of this form with next communication to applicant.</p>			

T¹ - Place a check mark in this area when an English language Translation is attached.



APPLICATION NO.	ISSUE DATE	PATENT NO.	ATTORNEY DOCKET NO.	CONFIRMATION NO.
14/485,612	01/26/2016	9245314	REDCOM.007C4	1068

20995 7590 01/06/2016
KNOBBE MARTENS OLSON & BEAR LLP
2040 MAIN STREET
FOURTEENTH FLOOR
IRVINE, CA 92614

ISSUE NOTIFICATION

The projected patent number and issue date are specified above.

Determination of Patent Term Adjustment under 35 U.S.C. 154 (b) (application filed on or after May 29, 2000)

The Patent Term Adjustment is 0 day(s). Any patent to issue from the above-identified application will include an indication of the adjustment on the front page.

If a Continued Prosecution Application (CPA) was filed in the above-identified application, the filing date that determines Patent Term Adjustment is the filing date of the most recent CPA.

Applicant will be able to obtain more detailed information by accessing the Patent Application Information Retrieval (PAIR) WEB site (<http://pair.uspto.gov>).

Any questions regarding the Patent Term Extension or Adjustment determination should be directed to the Office of Patent Legal Administration at (571)-272-7702. Questions relating to issue and publication fee payments should be directed to the Application Assistance Unit (AAU) of the Office of Data Management (ODM) at (571)-272-4200.

APPLICANT(s) (Please see PAIR WEB site <http://pair.uspto.gov> for additional applicants):

James H. Jannard, Las Vegas, NV;
RED.COM, INC., Irvine, CA;
Thomas Graeme Nattress, Acton, CANADA;

The United States represents the largest, most dynamic marketplace in the world and is an unparalleled location for business investment, innovation, and commercialization of new technologies. The USA offers tremendous resources and advantages for those who invest and manufacture goods here. Through SelectUSA, our nation works to encourage and facilitate business investment. To learn more about why the USA is the best country in the world to develop technology, manufacture products, and grow your business, visit SelectUSA.gov.

AO 120 (Rev. 08/10)

TO: Mail Stop 8 Director of the U.S. Patent and Trademark Office P.O. Box 1450 Alexandria, VA 22313-1450	REPORT ON THE FILING OR DETERMINATION OF AN ACTION REGARDING A PATENT OR TRADEMARK
---	---

In Compliance with 35 U.S.C. § 290 and/or 15 U.S.C. § 1116 you are hereby advised that a court action has been filed in the U.S. District Court Central District of California, Southern division on the following

Trademarks or Patents. (the patent action involves 35 U.S.C. § 292.):

DOCKET NO. 8:16-cv-594	DATE FILED	U.S. DISTRICT COURT Central District of California, Southern division
PLAINTIFF Red.com, Inc. dba Red Digital Camera, a Washington corporation		DEFENDANT Nokia USA Inc., a Delaware corporation, and Nokia Technologies, LTD., an unknown corporate entity
PATENT OR TRADEMARK NO.	DATE OF PATENT OR TRADEMARK	HOLDER OF PATENT OR TRADEMARK
1 8,174,560 B2	5/8/2012	Red.com, Inc.
2 9,019,393 B2	4/28/2015	Red.com, Inc.
3 9,245,314 B2	1/26/2016	Red.com, Inc
4		
5		

In the above—entitled case, the following patent(s)/ trademark(s) have been included:

DATE INCLUDED	INCLUDED BY <input type="checkbox"/> Amendment <input type="checkbox"/> Answer <input type="checkbox"/> Cross Bill <input type="checkbox"/> Other Pleading	
PATENT OR TRADEMARK NO.	DATE OF PATENT OR TRADEMARK	HOLDER OF PATENT OR TRADEMARK
1		
2		
3		
4		
5		

In the above—entitled case, the following decision has been rendered or judgement issued:

DECISION/JUDGEMENT

CLERK	(BY) DEPUTY CLERK	DATE
-------	-------------------	------

Copy 1—Upon initiation of action, mail this copy to Director Copy 3—Upon termination of action, mail this copy to Director
 Copy 2—Upon filing document adding patent(s), mail this copy to Director Copy 4—Case file copy

AO 120 (Rev. 08/10)

TO: Mail Stop 8 Director of the U.S. Patent and Trademark Office P.O. Box 1450 Alexandria, VA 22313-1450	REPORT ON THE FILING OR DETERMINATION OF AN ACTION REGARDING A PATENT OR TRADEMARK
---	---

In Compliance with 35 U.S.C. § 290 and/or 15 U.S.C. § 1116 you are hereby advised that a court action has been filed in the U.S. District Court Eastern District of Texas, Marshall Division on the following

Trademarks or Patents. (the patent action involves 35 U.S.C. § 292.):

DOCKET NO. 2:16-cv-00937	DATE FILED 8/24/2016	U.S. DISTRICT COURT Eastern District of Texas, Marshall Division
PLAINTIFF RED.COM, INC., dba RED DIGITAL CINEMA, a Washington corporation		DEFENDANT SONY CORPORATION OF AMERICA, a New York corporation, and SONY ELECTRONICS INC., a Delaware corporation
PATENT OR TRADEMARK NO.	DATE OF PATENT OR TRADEMARK	HOLDER OF PATENT OR TRADEMARK
1		PLEASE SEE ATTACHMENT FOR 1-7 PATENTS
2		
3		
4		
5		

In the above—entitled case, the following patent(s)/ trademark(s) have been included:

DATE INCLUDED	INCLUDED BY <input type="checkbox"/> Amendment <input type="checkbox"/> Answer <input type="checkbox"/> Cross Bill <input type="checkbox"/> Other Pleading	
PATENT OR TRADEMARK NO.	DATE OF PATENT OR TRADEMARK	HOLDER OF PATENT OR TRADEMARK
1		
2		
3		
4		
5		

In the above—entitled case, the following decision has been rendered or judgement issued:

DECISION/JUDGEMENT

CLERK	(BY) DEPUTY CLERK	DATE
-------	-------------------	------

Copy 1—Upon initiation of action, mail this copy to Director Copy 3—Upon termination of action, mail this copy to Director
 Copy 2—Upon filing document adding patent(s), mail this copy to Director Copy 4—Case file copy

RED.COM, INC.

v.

SONY CORPORATION OF AMERICA

**ATTACHMENT TO
REPORT ON THE FILING OR DETERMINATION OF AN ACTION
REGARDING A PATENT OR TRADEMARK**

PATENT OR TRADEMARK NO.	DATE OF PATENT OR TRADEMARK	HOLDER OF PATENT OR TRADEMARK
1. 8,174,560	5/8/2012	RED.COM, INC.
2. 8,358,357	1/22/2013	RED.COM, INC.
3. 8,477,238	7/2/2013	RED.COM, INC.
4. 8,773,581	7/8/2014	RED.COM, INC.
5. 9,019,393	4/28/2015	RED.COM, INC.
6. 9,019,397	4/28/2015	RED.COM, INC.
7. 9,245,314	1/26/2016	RED.COM, INC.
8.		
9.		
10.		
11.		
12.		
13.		
14.		
15.		

AO 120 (Rev. 08/10)

TO: Mail Stop 8 Director of the U.S. Patent and Trademark Office P.O. Box 1450 Alexandria, VA 22313-1450	REPORT ON THE FILING OR DETERMINATION OF AN ACTION REGARDING A PATENT OR TRADEMARK
--	---

In Compliance with 35 U.S.C. § 290 and/or 15 U.S.C. § 1116 you are hereby advised that a court action has been filed in the U.S. District Court Eastern District of Texas, Marshall Division on the following

Trademarks or Patents. (the patent action involves 35 U.S.C. § 292.);

DOCKET NO. 2:16-cv-00937	DATE FILED 8/24/2016	U.S. DISTRICT COURT Eastern District of Texas, Marshall Division
PLAINTIFF RED.COM, INC., dba RED DIGITAL CINEMA, a Washington corporation		DEFENDANT SONY CORPORATION OF AMERICA, a New York corporation, and SONY ELECTRONICS INC., a Delaware corporation
PATENT OR TRADEMARK NO.	DATE OF PATENT OR TRADEMARK	HOLDER OF PATENT OR TRADEMARK
1 see attached		PLEASE SEE ATTACHMENT FOR 1-7 PATENTS
2		
3		
4		
5		

In the above—entitled case, the following patent(s)/ trademark(s) have been included:

DATE INCLUDED	INCLUDED BY <input type="checkbox"/> Amendment <input type="checkbox"/> Answer <input type="checkbox"/> Cross Bill <input type="checkbox"/> Other Pleading		
PATENT OR TRADEMARK NO.	DATE OF PATENT OR TRADEMARK	HOLDER OF PATENT OR TRADEMARK	
1			
2			
3			
4			
5			

In the above—entitled case, the following decision has been rendered or judgement issued:

DECISION/JUDGEMENT

CLERK	(BY) DEPUTY CLERK	DATE
-------	-------------------	------

Copy 1—Upon initiation of action, mail this copy to Director Copy 3—Upon termination of action, mail this copy to Director
 Copy 2—Upon filing document adding patent(s), mail this copy to Director Copy 4—Case file copy

RED.COM, INC.

v.

SONY CORPORATION OF AMERICA

**ATTACHMENT TO
REPORT ON THE FILING OR DETERMINATION OF AN ACTION
REGARDING A PATENT OR TRADEMARK**

PATENT OR TRADEMARK NO.	DATE OF PATENT OR TRADEMARK	HOLDER OF PATENT OR TRADEMARK
1. 8,174,560	5/8/2012	RED.COM, INC.
2. 8,358,357	1/22/2013	RED.COM, INC.
3. 8,477,238	7/2/2013	RED.COM, INC.
4. 8,773,581	7/8/2014	RED.COM, INC.
5. 9,019,393	4/28/2015	RED.COM, INC.
6. 9,019,397	4/28/2015	RED.COM, INC.
7. 9,245,314	1/26/2016	RED.COM, INC.
8.		
9.		
10.		
11.		
12.		
13.		
14.		
15.		