

UNITED STATES PATENT AND TRADEMARK OFFICE

BEFORE THE PATENT TRIAL AND APPEAL BOARD

DATASPEED INC.,
Petitioner,

v.

SUCXESS, LLC,
Patent Owner.

IPR2020-00268
Patent 10,454,707 B2

Before TREVOR M. JEFFERSON, MINN CHUNG, and
NATHAN A. ENGELS, *Administrative Patent Judges*.

JEFFERSON, *Administrative Patent Judge*.

DECISION
Granting Institution of *Inter Partes* Review
35 U.S.C. § 314

I. INTRODUCTION

Dataspeed Inc. (“Petitioner”) filed a Petition under 35 U.S.C. § 311 requesting *inter partes* review of claims 1–20 of U.S. Patent No. 10,454,707 B2 (Ex. 1201, “the ’707 patent”). Paper 1 (“Pet.”). Success, LLC (“Patent Owner”) did not file a Preliminary Response.

We have authority under 35 U.S.C. § 314, which provides that an *inter partes* review may not be instituted unless the information presented in the Petition and the Preliminary Response shows that “there is a reasonable likelihood that the petitioner would prevail with respect to at least 1 of the claims challenged in the petition.” 35 U.S.C. § 314(a) (2018); *see also* 37 C.F.R § 42.4(a) (“The Board institutes the trial on behalf of the Director.”). The Supreme Court has held that under 35 U.S.C. § 314, we may not institute review of fewer than all claims challenged in the petition. *SAS Inst., Inc. v. Iancu*, 138 S. Ct. 1348, 1359–60 (2018).

Having considered the arguments and the associated evidence presented in the Petition, for the reasons described below, we institute *inter partes* review.

II. BACKGROUND

A. *Real Party-in-Interest*

Petitioner states that it, Dataspeed Inc., is the sole real party-in-interest. Pet. 2.

B. *Related Proceedings*

Petitioner and Patent Owner note that *Success LLC v. AutoX Technologies, Inc.*, Case No. 1:19-cv-02121 (D. Del.); *Success LLC v. Phantom Auto, Inc.*, Case No. 1:19-cv-02122 (D. Del.); *Success LLC v.*

Pony.ai, Inc., Case No. 1:19-cv-02123 (D. Del.); *Sucxess LLC v. SF Motors, Inc.*, Case No. 1:19-cv-02124 (D. Del.); and *Sucxess LLC v. WeRide Corp.*, Case No. 1:19-cv-02130 (D. Del.) are related matters. Pet. Paper 5, 1.

C. The '707 Patent (Ex. 1201)

Titled “Method, Apparatus and System for Retrofitting a Vehicle” (Ex. 1201, code [54]), the '707 patent states that a vehicle could be retrofitted to add, for example, an emergency call apparatus. Ex. 1201, 2:46–47. The retrofit apparatus is used to transmit a message on the vehicle data bus. *Id.* at 2:52–55. The '707 patent states that a retrofit apparatus may be added to the vehicle with two data buses, with the first bus used to communicate with the original vehicle equipment and the second bus used to communicate with the rest of the vehicle. *Id.* at 3:32–36. With respect to this communication, the '707 patent states that the retrofit apparatus can be configured to mimic command messages to enable the original vehicle equipment to perform specified functions not originally enabled. *Id.* at 9:28–9:50.

In one embodiment of the '707 patent, the retrofit apparatus is an emergency call apparatus 214 that sends a message to a first apparatus, i.e., telecommunication apparatus 200 as seen in Figure 4, reproduced below.

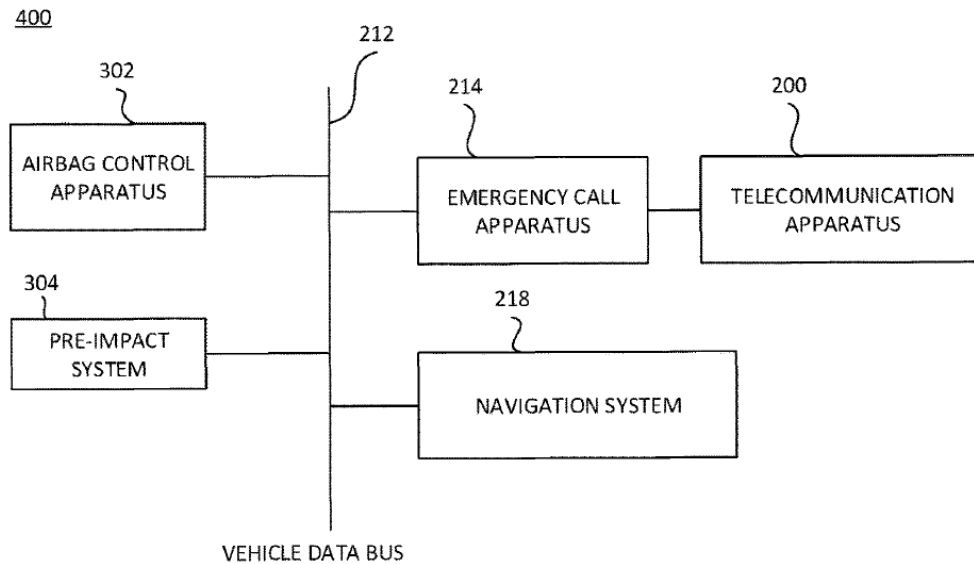

FIG. 4

Figure 4 illustrates vehicle communication system 400 having telecommunication apparatus 200 in communication with vehicle data bus 212 using an indirect connection through emergency call apparatus 214. Ex. 1201, 7:59–63. Emergency call apparatus 214 mimics the dial command message by using “the same message identifier segment that has been assigned to navigation system 218 when transmitting its telephone dial command message.” *Id.* at 9:39–41. “By sharing the same message identifier segment a telephone dial command message originating from emergency call apparatus 214 and a telephone dial command message originating from navigation system 218 become indistinguishable for the telecommunication apparatus 200.” *Id.* at 9:42–9:47. “Telecommunication apparatus 200 hence responds properly to a telephone dial command message originating from emergency call apparatus 214 even though it may not have been designed for this purpose.” *Id.* at 9:46–50.

Messages to telecommunication apparatus 200 are communicated through first and second data buses, as depicted in Figure 7, reproduced below.

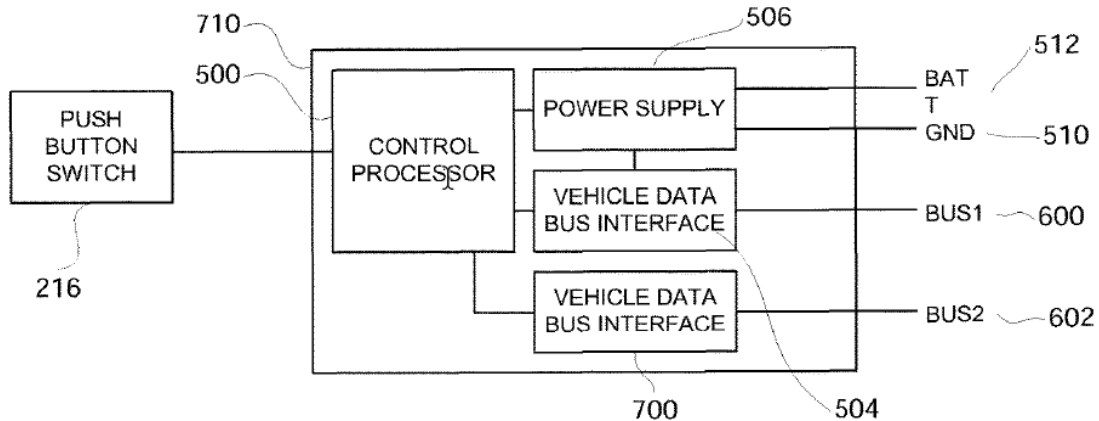

FIG. 7

Figure 7 is a block diagram that depicts emergency call apparatus 710. Ex. 1201, 8:36–37. In Figure 7, control processor 500 communicates with telecommunication apparatus 200 through vehicle data bus interface 504 and electric terminal 600. *Id.* at 8:37–40. Control processor 500 also communicates with other electronic modules connected to vehicle data bus 212 through second vehicle data bus interface 700 and electric terminal 602. *Id.* at 8:40–47. “Control processor 500 retransmits any messages it receives from vehicle data bus interface 504 through vehicle data bus interface 700 and any messages it receives from vehicle data bus interface 700 through vehicle data bus interface 504, thereby functionally connecting telecommunication apparatus 200 with vehicle data bus 212.” *Id.* at 8:50–56.

Explore Litigation Insights

Docket Alarm provides insights to develop a more informed litigation strategy and the peace of mind of knowing you're on top of things.

Real-Time Litigation Alerts



Keep your litigation team up-to-date with **real-time alerts** and advanced team management tools built for the enterprise, all while greatly reducing PACER spend.

Our comprehensive service means we can handle Federal, State, and Administrative courts across the country.

Advanced Docket Research



With over 230 million records, Docket Alarm's cloud-native docket research platform finds what other services can't. Coverage includes Federal, State, plus PTAB, TTAB, ITC and NLRB decisions, all in one place.

Identify arguments that have been successful in the past with full text, pinpoint searching. Link to case law cited within any court document via Fastcase.

Analytics At Your Fingertips



Learn what happened the last time a particular judge, opposing counsel or company faced cases similar to yours.

Advanced out-of-the-box PTAB and TTAB analytics are always at your fingertips.

API

Docket Alarm offers a powerful API (application programming interface) to developers that want to integrate case filings into their apps.

LAW FIRMS

Build custom dashboards for your attorneys and clients with live data direct from the court.

Automate many repetitive legal tasks like conflict checks, document management, and marketing.

FINANCIAL INSTITUTIONS

Litigation and bankruptcy checks for companies and debtors.

E-DISCOVERY AND LEGAL VENDORS

Sync your system to PACER to automate legal marketing.