

UNITED STATES PATENT AND TRADEMARK OFFICE

BEFORE THE PATENT TRIAL AND APPEAL BOARD

ASETEK DANMARK A/S,
Petitioner,

v.

COOLIT SYSTEMS, INC.,
Patent Owner.

IPR2020-00747
Patent 9,057,567 B2

Before FRANCES L. IPPOLITO, SCOTT C. MOORE, and
BRENT M. DOUGAL, *Administrative Patent Judges*.

MOORE, *Administrative Patent Judge*.

JUDGMENT
Final Written Decision
Determining All Challenged Claims Unpatentable
35 U.S.C. § 318(a)
Denying Patent Owner's Motion to Exclude
37 C.F.R. § 42.64

I. INTRODUCTION

Asetek Danmark A/S (“Petitioner”) filed a petition requesting an *inter partes* review of claims 1, 2, 3, 5, 7, 25, and 28 of U.S. Patent No. 9,057,567 B2 (“the ’567 Patent”). Paper 2 (“Petition” or “Pet.”). CoolIT Systems, Inc. (“Patent Owner”) filed a preliminary response. Paper 5. Pursuant to our authorization, Petitioner filed a reply to Patent Owner’s preliminary response (Paper 6), and Patent Owner filed a sur-reply in support of Patent Owner’s preliminary response (Paper 8). We instituted an *inter partes* review as to all claims and grounds set forth in the Petition. Paper 10 (“Institution Decision”).

After institution, Patent Owner filed a response to the Petition (Paper 19, “Response” or “Resp.”), Petitioner filed a reply to the Response (Paper 24, “Reply”), and Patent Owner filed a sur-reply (Paper 30, “Sur-Reply”). Patent Owner also filed a statutory disclaimer of claim 28, so claim 28 is no longer part of this proceeding. *See* Ex. 3001. In addition, Patent Owner filed a motion to exclude (Paper 31, “Motion to Exclude”), Petitioner filed an opposition to the Motion to Exclude (Paper 33), and Patent Owner filed a reply in support of the Motion to Exclude (Paper 36). An oral hearing was held on June 22, 2021, and a transcript of the hearing is in the record. Paper 41 (“Tr.”).

We have jurisdiction under 35 U.S.C. § 6. This Final Written Decision is issued pursuant to 35 U.S.C. § 318(a). For the reasons that follow, we determine that Petitioner has shown by a preponderance of the evidence that claims 1, 2, 3, 5, 7, and 25 (all of the challenged claims that remain after Patent Owner’s statutory disclaimer) are unpatentable. We also deny Patent Owner’s Motion to Exclude.

IPR2020-00747
Patent 9,057,567 B2

A. *Related Matters*

Patent Owner sued Petitioner for infringement of the '567 Patent in *Asetek Danmark A/S v. CoolIT Systems, Inc.*, No. 3:19-cv-00410-EMC (N.D. Cal) (the “district court case”). Pet. 95. Petitioner points out that the '567 Patent is related to issued patents U.S. 8,746,330 B2 and U.S. 9,453,691 B2. *Id.*

The '567 Patent, filed February 18, 2014, as U.S. Application 14/183,443, is a continuation of U.S. Application 14/166,657, which is a continuation of U.S. Application 13/401,618, which is a continuation-in-part of U.S. Application 12/189,476, now U.S. Patent No. 8,746,330 B2 (Ex. 1004, “the '330 Patent”). Ex. 1001, codes (21), (22), (63). Patent Owner points out that the '330 Patent “[has] survived [an] *inter partes* challenge” in IPR2015-01276. Paper 5, 6 n.3.

U.S. Application No. 12/189,476 was published as U.S. Publication No. 2009/0071625 A1. Ex. 1011 (“Lyon”), codes (21), (43). The '567 Patent claims priority to U.S. Provisional Application No. 60/954,987 (Ex. 1005, “the 2007 Provisional”) and U.S. Provisional Application No. 61/512,379 (Ex. 1006, “the 2011 Provisional”). Ex. 1001, code (60); *see also* Pet. 20–21.

On April 10, 2020, Petitioner filed a separate petition requesting *inter partes* review of claims 1, 2, 4, 5, 9, and 13–15 of U.S. Patent No. 10,274,266 B2 (“the '266 Patent”). *See* IPR2020-00825 (“the '825 IPR”), Papers 2, 41. The '266 Patent is a continuation of U.S. Patent No. 9,909,820 B2, which is a continuation of U.S. Patent No. 9,453,691 B2, which is a continuation-in-part of the '330 Patent. '825 IPR, Paper 2, 16. The '825 IPR remains pending.

B. The '567 Patent

The '567 Patent is directed to a fluid heat exchange system for accepting and dissipating thermal energy to cool electronic and other devices. Ex. 1001, 1:17–25.

Figure 1, reproduced below, depicts such a system.

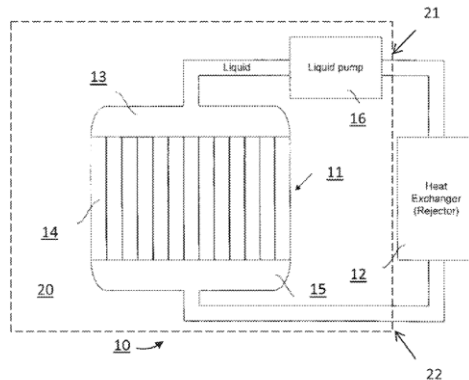

FIG. 1

Figure 1 is a diagram of a fluid circuit configured to transfer heat using a circulating liquid. Ex. 1001, 5:22–23. In Figure 1, liquid circulates through fluid circuit 10 by entering inlet 21, moving through heat exchanger 11, and exiting outlet 22. *Id.* at 6:46–57, 7:31–54. Heat exchanger 11 has manifolds 13, 15 and passages 14. *Id.* at 7:42–47.

Figure 2, reproduced below, depicts an exemplary embodiment of a heat exchanger.

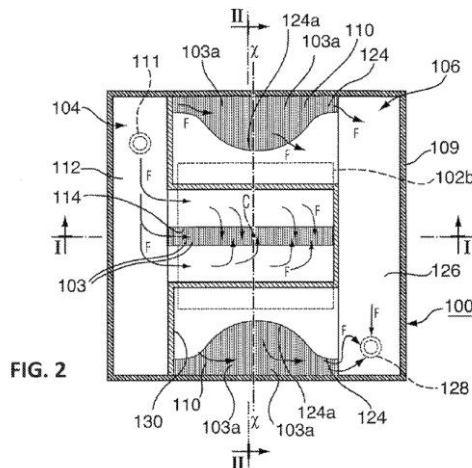

FIG. 2

Figure 2 is a top plan view depicting internal components of heat exchanger 100. Ex. 1001, 5:24–26. Heat exchanger 100 includes housing 109, inlet port 111, fluid inlet passage 104, inlet opening 114, microchannels 103, seal 130, fluid outlet opening 124, fluid outlet passage 106, and outlet port 128. *Id.* at 7:56–62, 9:17–10:56, 12:1–4. Each microchannel 103 is defined by a recessed groove extending transversely between adjacent fins. *Id.* at 2:40–43. Heat exchanging fluid F flows in the directions indicated by the arrows. *Id.* at 11:30–33. Heat exchanging fluid F enters microchannels 103 and splits into two sub flows in opposite directions to pass outwardly from inlet opening 114 towards outlet fluid openings 124. *Id.* at 11:14–11:50.

Figure 4, reproduced below, shows a sectional view along line II–II of Figure 2. Ex. 1001, 5:28.¹

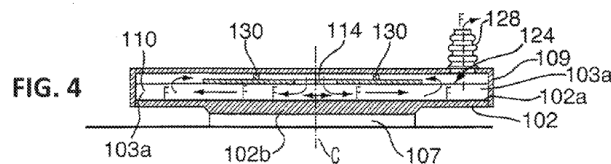

Figure 4 depicts housing 109 including heat spreader plate 102 (which operates as an outer limit of a heat sink), and heat exchanging fluid F flowing in two opposite directions within microchannels 103. Ex. 1001, 7:56–62, 11:14–11:50. Seal 130 separates fluid inlet passage 104 from fluid outlet passage 106 so that fluid F must pass through microchannels 103 and past surface 102a of heat spreader 102. *Id.* at 12:1–4.

¹ The '567 Patent incorrectly refers to line II–II “of FIG. 3” rather than “of FIG. 2.” Ex. 1001, 5:28.

Explore Litigation Insights

Docket Alarm provides insights to develop a more informed litigation strategy and the peace of mind of knowing you're on top of things.

Real-Time Litigation Alerts



Keep your litigation team up-to-date with **real-time alerts** and advanced team management tools built for the enterprise, all while greatly reducing PACER spend.

Our comprehensive service means we can handle Federal, State, and Administrative courts across the country.

Advanced Docket Research



With over 230 million records, Docket Alarm's cloud-native docket research platform finds what other services can't. Coverage includes Federal, State, plus PTAB, TTAB, ITC and NLRB decisions, all in one place.

Identify arguments that have been successful in the past with full text, pinpoint searching. Link to case law cited within any court document via Fastcase.

Analytics At Your Fingertips



Learn what happened the last time a particular judge, opposing counsel or company faced cases similar to yours.

Advanced out-of-the-box PTAB and TTAB analytics are always at your fingertips.

API

Docket Alarm offers a powerful API (application programming interface) to developers that want to integrate case filings into their apps.

LAW FIRMS

Build custom dashboards for your attorneys and clients with live data direct from the court.

Automate many repetitive legal tasks like conflict checks, document management, and marketing.

FINANCIAL INSTITUTIONS

Litigation and bankruptcy checks for companies and debtors.

E-DISCOVERY AND LEGAL VENDORS

Sync your system to PACER to automate legal marketing.