

**IN THE UNITED STATES PATENT AND TRADEMARK OFFICE**

In re Patent of: Poeze et al.  
U.S. Patent No.: 10,258,265                      Attorney Docket No.: 50095-00006IP1  
Issue Date: April 16, 2019  
Appl. Serial No.: 16/212,440  
Filing Date: December 6, 2018  
Title: MULTI-STREAM DATA COLLECTION SYSTEM FOR  
NONINVASIVE MEASUREMENT OF BLOOD  
CONSTITUENTS

**DECLARATION OF DR. THOMAS W. KENNY**

**Declaration**

I declare that all statements made herein on my own knowledge are true and that all statements made on information and belief are believed to be true, and further, that these statements were made with the knowledge that willful false statements and the like so made are punishable under Section 1001 of Title 18 of the United States Code.

By:  \_\_\_\_\_

Thomas W. Kenny, Ph.D.

## Contents

|  |    |
|--|----|
| I. QUALIFICATIONS AND BACKGROUND INFORMATION.....  | 5  |
| II. OVERVIEW OF CONCLUSIONS FORMED .....   | 11 |
| III. LEVEL OF ORDINARY SKILL IN THE ART .....  | 13 |
| IV. LEGAL STANDARDS .....  | 14 |
| A. Terminology .....   | 14 |
| B. Legal Standards for Anticipation.....   | 14 |
| C. Legal Standards for Obviousness .....   | 15 |
| V. HISTORICAL AND TECHNICAL OVERVIEW.....  | 20 |
| VI. THE '265 patent .....  | 20 |
| A. Overview of the '265 patent.....  | 20 |
| VII. SUMMARY OF THE PRIOR ART.....   | 25 |
| A. Overview of Aizawa.....   | 25 |
| B. Overview of Inokawa .....   | 28 |
| C. Overview of Ohsaki.....   | 32 |
| D. Overview of Mendelson-1988.....   | 34 |
| E. Overview of Mendelson-2006.....   | 36 |
| F. Overview of Beyer, Jr.....  | 40 |
| VIII. GROUND 1A – Claims 1-4, 6-14, 16, 17, 19-23, and 26-29 Are Rendered<br>Obvious by Aizawa in view of Inokawa..... | 41 |
| A. Claim 1 .....   | 41 |
| B. Claim 2 .....   | 58 |
| C. Claim 3 .....   | 59 |
| D. Claim 4 .....   | 60 |
| E. Claim 6 .....   | 63 |
| F. Claim 7 .....   | 63 |
| G. Claim 8 .....   | 64 |
| H. Claim 9 .....   | 65 |
| I. Claim 10 .....  | 67 |
| J. Claim 11 .....  | 68 |

|   |     |
|---|-----|
| K. Claim 12 .....   | 69  |
| L. Claim 13 .....   | 71  |
| M. Claim 14 .....   | 71  |
| N. Claim 16 .....   | 72  |
| O. Claim 17 .....   | 72  |
| P. Claim 19 .....   | 73  |
| Q. Claim 20 .....   | 73  |
| R. Claim 21 .....   | 74  |
| S. Claim 22 .....   | 75  |
| T. Claim 23 .....   | 76  |
| U. Claim 26 .....   | 77  |
| V. Claim 27 .....   | 79  |
| W. Claim 28 .....   | 80  |
| X. Claim 29 .....   | 81  |
| IX. GROUND 1B –Claims 1-4, 6-14, 16, 17, 19-23, and 26-29 Are Rendered<br>Obvious by Aizawa in view of Inokawa and Ohsaki ..... | 81  |
| A. Claims 1-4, 6-14, 16, 17, 19-23, and 26-29 .....   | 81  |
| X. GROUND 1C – Claims 23-24 Are Rendered Obvious by Aizawa in view of<br>Inokawa and Mendelson-2006.....                        | 84  |
| A. Claim 23 .....   | 84  |
| B. Claim 24 .....   | 88  |
| XI. GROUND 1D – Claims 23-24 Are Rendered Obvious by Aizawa in view of<br>Inokawa, Goldsmith, and Lo.....                       | 89  |
| A. Claim 23 .....   | 89  |
| B. Claim 24 .....   | 93  |
| XII. GROUND 1E – Claim 25 Is Rendered Obvious by Aizawa in view of<br>Inokawa, Mendelson-2006, and Beyer, Jr. ....              | 93  |
| A. Claim 25 .....   | 93  |
| XIII. GROUND 2A – Claims 1-4, 6-14, 16-22, and 26-30 Are Rendered Obvious<br>by Mendelson-1988 in View of Inokawa .....         | 96  |
| A. Claim 1 .....  | 97  |
| B. Claim 2 .....  | 108 |

C. Claim 3 .....109

D. Claim 4 .....110

E. Claim 6 .....111

F. Claim 7 .....111

G. Claim 8 .....112

H. Claim 9 .....113

I. Claim 10 .....113

J. Claim 11 .....114

K. Claim 12 .....115

L. Claim 13 .....117

M. Claim 14 .....118

N. Claim 16 .....118

O. Claim 17 .....118

P. Claim 18 .....119

Q. Claim 19 .....119

R. Claim 20 .....120

S. Claim 21 .....121

T. Claim 22 .....122

U. Claim 26 .....123

V. Claim 27 .....126

W. Claim 28 .....127

X. Claim 29 .....130

Y. Claim 30 .....130

XIV. GROUND 2B – Claims 23-24 Are Rendered Obvious by Mendelson-1988 in view of Inokawa and Mendelson-2006.....131

    A. Claim 23 .....131

    B. Claim 24 .....133

XV. GROUND 2C – Claim 25 Is Rendered Obvious by Mendelson-1988 in view of Inokawa, Mendelson-2006, and Beyer, Jr. ....134

    A. Claim 25 .....134

XVI. CONCLUSION.....138

## **I. QUALIFICATIONS AND BACKGROUND INFORMATION**

1. My education and experience are described more fully in the attached curriculum vitae (APPLE-1004). For ease of reference, I have highlighted certain information below.

2. My academic and professional background is in Physics, Mechanical Engineering, Sensing, and Robotics, with a research specialization focused on microfabricated physical sensors, and I have been working in those fields since the completion of my Ph.D. more than 30 years ago. The details of my background and education and a listing of all publications I have authored in the past 35 years are provided in my curriculum vitae, attached as Exhibit A. Below I provide a short summary of my education and experience which I believe to be most pertinent to the opinions that I express here.

3. I received a B.S. in Physics from University of Minnesota, Minneapolis in 1983, and a Ph.D. in Physics from University of California at Berkeley in 1989. I was educated as a Physicist specializing in sensors and measurement. My Physics Ph.D. thesis involved measurements of the heat capacity of monolayers of atoms on surfaces, and relied on precision measurements of temperature and power using time-varying electrical signals, and also on the design and construction of miniature sensor components and associated electrical circuits for conditioning and conversion to digital format.

4. After completion of my Ph.D. in Physics at U.C. Berkeley in 1989, I joined the Jet Propulsion Laboratory (JPL) in Pasadena, CA, as a staff scientist, and began working on miniature sensors and instruments for small spacecraft. This work involved the use of silicon microfabrication technologies for miniaturization of the sensors, and served as my introduction to the field of micro-electromechanical systems (MEMS), or the study of very small mechanical sensors powered by electricity and used for detection of physical and chemical signals.

5. While at JPL, we developed accelerometers, uncooled infrared sensors, magnetometers, seismometers, force and displacement sensors, soil chemistry sensors, miniature structures for trapping interstellar dust, and many other miniature devices. Some of these projects led to devices that were launched with spacecraft headed for Mars and for other interplanetary missions. Much of this work involved the use of physical sensors for detection of small forces and displacements using micromechanical sensors.

6. I am presently the Richard Weiland Professor at the Department of Mechanical Engineering at Stanford University, where I have taught for the past 26 years. I am also currently the Senior Associate Dean of Engineering for Student Affairs at Stanford.

7. For 26 years, I have taught courses on Sensors and Mechatronics at Stanford University. The “Introduction to Sensors” course is a broad overview of all

sensing technologies, from thermometers, to inertial sensors, ultrasound devices, flow sensors, optical and IR sensors, chemical sensors, pressure sensors, and many others, and has included sensors based on changes in capacitance, resistance, piezoelectricity. This course specifically included different mechanisms for sensing heart rate, blood pressure, blood chemistry, cardiovascular blood flow and pressure drops, intraocular pressure and other physiological measurements, as well as activity monitoring (step counting, stair-counting, etc). I first taught this course at Stanford in the Spring of 1994, and I offered this course at least annually until 2016, when my duties as Senior Associate Dean made this impractical.

8. The “Introduction to Mechatronics” course is a review of the mechanical, electrical and computing technologies necessary to build systems with these contents, which include everything from cars and robots to cellphones and other consumer electronics devices. In this class, we routinely use IR, LEDs, and photosensors as a way of detecting proximity to objects in the space around miniature robots. We also use inertial sensors to detect movement, and a number of sensors, such as encoders to measure changes in position and trajectory. I was one of the instructors for the first offering of this course in 1995, and this course has been offered at least once each year ever since, with plans already underway for the Winter 2021 offering. The 2020 offering was just completed, and was

highly-successful with 120 undergraduate and graduate students from many engineering and science disciplines.

9. I am co-author of a textbook titled “Introduction to Mechatronic Design,” which broadly covers the topic of integration of mechanical, electronic and computer systems design into “smart products.” This textbook includes chapters on Microprocessors, Programming Languages, Software Design, Electronics, Sensors, Signal Conditioning, and Motors, as well as topics such as Project Management, Troubleshooting, and Synthesis.

10. My research group has focused on the area of microsensors and microfabrication—a domain in which we design and build micromechanical sensors using silicon microfabrication technologies. The various applications for these technologies are numerous.

11. I have advised 69 Ph.D. students that have completed Ph.D. degrees and many more M.S. and B.S. students in Engineering during my time at Stanford.

12. I have published over 250 technical papers in refereed journals and conferences in the field of sensors, MEMS, and measurements. I have further presented numerous conference abstracts, posters, and talks in my field. I am a named inventor on 50 patents in my areas of work.

13. I have previously served as an expert on a patent infringement case involving the mounting and use of pressure sensors on guidewire catheters for



cardiovascular procedures that included a number of sensing aspects, such as recording static and dynamic pressure signals, and compensating for electrical and mechanical errors. I have also previously served as an expert on a patent infringement case involving the design and use of miniature inertial sensors. That case involved the design and operations of micromechanical sensors, and particularly the use of inertial sensors for detection of states of movement and rest. I have also served as an expert in a patent infringement case involving the use of sensors on athletic shoes for determining athletic performance. More recently, I served as an expert in a patent infringement case involving optical proximity sensors in smartphones. My CV is attached as APPLE-1004 and includes a full listing of all cases in which I have testified at deposition or trial in the preceding four years.

14. I have been retained on behalf of Apple Inc. to offer technical opinions relating to U.S. Patent No. 10,258,265 (“the ’265 patent”) and prior art references relating to its subject matter. I have reviewed the ’265 patent, relevant excerpts of the prosecution history of the ’265 patent. I have also reviewed the following prior art references:

| <b>Prior Art Reference</b>                                   |
|--|
| U.S. Pub. No. 2002/0188210 to Aizawa (“Aizawa”) (APPLE-1006) |

|   |
|---|
| English translation of JP 2006-296564 to Inokawa et al. (“Inokawa”) (APPLE-1007, APPLE-1008)  |
| U.S. Pub. No. 2001/0056243 to Ohsaki et al. (“Ohsaki”) (APPLE-1014)   |
| “Design and Evaluation of a New Reflectance Pulse Oximeter Sensor,” Y. Mendelson, et al.; Worcester Polytechnic Institute, Biomedical Engineering Program, Worcester, MA 01609; Association for the Advancement of Medical Instrumentation, vol. 22, No. 4, 1988; pp. 167-173 (“Mendelson-1988”) (APPLE-1015) |
| “A Wearable Reflectance Pulse Oximeter for Remote Physiological Monitoring,” Y. Mendelson, et al.; Proceedings of the 28th IEEE EMBS Annual International Conference, 2006; pp. 912-915 (“Mendelson-2006”) (APPLE-1016)   |
| U.S. Pat. No. 7,031,728 (“Beyer, Jr.”) (APPLE-1019)   |
| U.S. Pub. No. 2007/0093786 to Goldsmith et al. (“Goldsmith”) (APPLE-1027)   |
| U.S. Pub. No. 2004/0138568 to Lo et al. (“Lo”) (APPLE-1028)   |

15. I have also reviewed various supporting references and other documentation as further noted in my opinions below.

16. Counsel has informed me that I should consider these materials through the lens of one of ordinary skill in the art related to the ’265 patent at the time of the earliest possible priority date of the ’265 patent, and I have done so during my review of these materials. The application leading to the ’265 patent was filed on December 6, 2018, and claims the benefit of priority to a provisional application filed July 3, 2008 (“the Critical Date”). Counsel has informed me that the Critical Date represents the earliest possible priority date to which the challenged claims of

'265 patent are entitled, and I have therefore used that Critical Date in my analysis below.

17. I have no financial interest in the party or in the outcome of this proceeding. I am being compensated for my work as an expert on an hourly basis. My compensation is not dependent on the outcome of these proceedings or the content of my opinions.

18. In writing this declaration, I have considered the following: my own knowledge and experience, including my work experience in the fields of mechanical engineering, computer science, biomedical engineering, and electrical engineer; my experience in teaching those subjects; and my experience in working with others involved in those fields. In addition, I have analyzed various publications and materials, in addition to other materials I cite in my declaration.

19. My opinions, as explained below, are based on my education, experience, and expertise in the fields relating to the '265 patent. Unless otherwise stated, my testimony below refers to the knowledge of one of ordinary skill in the fields as of the Critical Date, or before. Any figures that appear within this document have been prepared with the assistance of Counsel and reflect my understanding of the '265 patent and the prior art discussed below.

## **II. OVERVIEW OF CONCLUSIONS FORMED**

20. This declaration explains the conclusions that I have formed based on my analysis. To summarize those conclusions, based upon my knowledge and experience and my review of the prior art publications listed above, I believe that:

- Claims 1-4, 6-14, 16, 17, 19-23, 26-29 are rendered obvious by Aizawa and Inokawa.
- Claims 1-4, 6-14, 16, 17, 19-23, 26-29 are rendered obvious by Aizawa, Inokawa, and Ohsaki.
- Claims 23 and 24 are rendered obvious by Aizawa, Inokawa, and Mendelson-2006.
- Claims 23 and 24 are rendered obvious by Aizawa, Inokawa, Goldsmith, and Lo
- Claim 25 is rendered obvious by Aizawa, Inokawa, Mendelson-2006, and Beyer, Jr.
- Claims 1-4, 6-14, 16-22, 26-30 are rendered obvious by Mendelson-1988 and Inokawa.
- Claims 23 and 24 are rendered obvious by Mendelson-1988, Inokawa, and Mendelson-2006.
- Claim 25 is rendered obvious by Mendelson-1988, Inokawa, Mendelson-2006, and Beyer, Jr.

### **III. LEVEL OF ORDINARY SKILL IN THE ART**

21. In my opinion, one of ordinary skill in the art relating to, and at the time of, the invention of the '265 patent would have been someone with a working knowledge of physiological monitoring technologies. The person would have had a Bachelor of Science degree in an academic discipline emphasizing the design of electrical, computer, or software technologies, in combination with training or at least one to two years of related work experience with capture and processing of data or information, including but not limited to physiological monitoring technologies. Alternatively, the person could have also had a Master of Science degree in a relevant academic discipline with less than a year of related work experience in the same discipline.

22. Based on my experiences, I have a good understanding of the capabilities of one of ordinary skill. Indeed, I have taught, participated in organizations, and worked closely with many such persons over the course of my career. Based on my knowledge, skill, and experience, I have an understanding of the capabilities of one of ordinary skill. For example, from my industry experience, I am familiar with what an engineer would have known and found predictable in the art. From teaching and supervising my post-graduate students, I also have an understanding of the knowledge that a person with this academic experience possesses.

Furthermore, I possess those capabilities myself.

#### **IV. LEGAL STANDARDS**

##### **A. Terminology**

23. I have been informed by Counsel and understand that the best indicator of claim meaning is its usage in the context of the patent specification as understood by one of ordinary skill. I further understand that the words of the claims should be given their plain meaning unless that meaning is inconsistent with the patent specification or the patent's history of examination before the Patent Office.

Counsel has also informed me, and I understand that, the words of the claims should be interpreted as they would have been interpreted by one of ordinary skill at the time of the invention was made (not today). Because I do not know at what date the invention as claimed was made, I have used the earliest priority date of the '265 patent as the point in time for claim interpretation purposes. That date was July 3, 2008.

##### **B. Legal Standards for Anticipation**

24. I have been informed by Counsel and understand that documents and materials that qualify as prior art can render a patent claim unpatentable as anticipated. I am informed by Counsel and understand that all prior art references are to be looked at from the viewpoint of a person of ordinary skill in the art.

25. I am informed by Counsel and understand that a challenged claim is unpatentable as "anticipated" under 35 U.S.C. § 102 if it is determined that all the limitations of the claim are described in a single prior art reference. I am informed

by Counsel and understand that, to anticipate a claim, a prior art reference must disclose, either expressly or inherently, each and every limitation of that claim and enable one of ordinary skill in the art to make and use the invention.

26. I have been informed by Counsel and understand that in an *inter partes* review, “the petitioner shall have the burden of proving a proposition of unpatentability,” including a proposition of anticipation, “by a preponderance of the evidence.” 35 U.S.C. §316(e).

### **C. Legal Standards for Obviousness**

27. I have been informed by Counsel and understand that documents and materials that qualify as prior art can render a patent claim unpatentable as obvious. I am informed by Counsel and understand that all prior art references are to be looked at from the viewpoint of a person of ordinary skill in the art at the time of the invention, and that this viewpoint prevents one from using his or her own insight or hindsight in deciding whether a claim is obvious.

28. I have been informed by Counsel and understand that a claim is unpatentable for obviousness under 35 U.S.C. § 103 (in the pre-AIA form of that statute that applies to the '265 patent) “if the differences between the subject matter sought to be patented and the prior art are such that the subject matter as a whole would have been obvious at the time the invention was made to a person having ordinary skill in the art to which said subject matter pertains.” I am informed by Counsel and

understand that obviousness may be based upon a combination of references. I am informed by Counsel and understand that the combination of familiar elements according to known methods is likely to be obvious when it does no more than yield predictable results. However, I am informed by Counsel and understand that a patent claim composed of several elements is not proved obvious merely by demonstrating that each of its elements was, independently, known in the prior art.

29. I am informed by Counsel and understand that when a patented invention is a combination of known elements, a court must determine whether there was an apparent reason to combine the known elements in the fashion claimed by the patent at issue by considering the teachings of prior art references, the effects of demands known to people working in the field or present in the marketplace, and the background knowledge possessed by a person having ordinary skill in the art.

30. I am informed by Counsel and understand that a patent claim composed of several limitations is not proved obvious merely by demonstrating that each of its limitations was independently known in the prior art. I am informed by counsel for the Patent Owner and understand that identifying a reason those elements would be combined can be important because inventions in many instances rely upon building blocks long since uncovered, and claimed discoveries almost of necessity will be combinations of what, in some sense, is already known. I am informed by



Counsel and understand that it is improper to use hindsight in an obviousness analysis, and that a patent's claims should not be used as a "roadmap."

31. I am informed by Counsel and understand that an obviousness inquiry requires consideration of the following factors: (1) the scope and content of the prior art; (2) the differences between the claims and the prior art; (3) the level of ordinary skill in the pertinent art; and (4) any objective indicia of non-obviousness, such as commercial success, long-felt but unresolved need, failure of others, industry recognition, copying, and unexpected results. I understand that the foregoing factors are sometimes referred to as the "Graham factors."

32. I have been informed by Counsel and understand that an obviousness evaluation can be based on a combination of multiple prior art references. I understand that the prior art references themselves may provide a suggestion, motivation, or reason to combine, but that the nexus linking two or more prior art references is sometimes simple common sense. I have been informed by Counsel and understand that obviousness analysis recognizes that market demand, rather than scientific literature, often drives innovation, and that a motivation to combine references may be supplied by the direction of the marketplace.

33. I have been informed by Counsel and understand that if a technique has been used to improve one device, and a person of ordinary skill at the time of invention would have recognized that it would improve similar devices in the same way,

using the technique is obvious unless its actual application is beyond his or her skill.

34. I have been informed by Counsel and understand that practical and common sense considerations should guide a proper obviousness analysis, because familiar items may have obvious uses beyond their primary purposes. I have been informed by Counsel and understand that a person of ordinary skill looking to overcome a problem will often be able to fit together the teachings of multiple prior art references. I have been informed by Counsel and understand that obviousness analysis therefore takes into account the inferences and creative steps that a person of ordinary skill would have employed at the time of invention.

35. I have been informed by Counsel and understand that a proper obviousness analysis focuses on what was known or obvious to a person of ordinary skill at the time of invention, not just the patentee. Accordingly, I understand that any need or problem known in the field of endeavor at the time of invention and addressed by the patent can provide a reason for combining the elements in the manner claimed.

36. I have been informed by Counsel and understand that a claim can be obvious in light of a single reference, without the need to combine references, if the elements of the claim that are not found explicitly or inherently in the reference can be supplied by the common sense of one of skill in the art.

37. I have been informed by Counsel and understand that secondary indicia of non-obviousness may include (1) a long felt but unmet need in the prior art that was satisfied by the invention of the patent; (2) commercial success of processes covered by the patent; (3) unexpected results achieved by the invention; (4) praise of the invention by others skilled in the art; (5) taking of licenses under the patent by others; (6) deliberate copying of the invention; (7) failure of others to find a solution to the long felt need; and (8) skepticism by experts. I understand that evidence of secondary indicia of non-obviousness, if available, should be considered as part of the obviousness analysis.

38. I have been informed by Counsel and understand that there must be a relationship between any such secondary considerations and the invention, and that contemporaneous and independent invention by others is a secondary consideration supporting an obviousness determination.

39. In sum, my understanding is that prior art teachings are properly combined where one of ordinary skill having the understanding and knowledge reflected in the prior art and motivated by the general problem facing the inventor, would have been led to make the combination of elements recited in the claims. Under this analysis, the prior art references themselves, or any need or problem known in the field of endeavor at the time of the invention, can provide a reason for combining the elements of multiple prior art references in the claimed manner.

40. I have been informed by Counsel and understand that in an *inter partes* review, “the petitioner shall have the burden of proving a proposition of unpatentability,” including a proposition of obviousness, “by a preponderance of the evidence.” 35 U.S.C. §316(e).

## **V. HISTORICAL AND TECHNICAL OVERVIEW**

41. The '265 patent and the prior art references discussed herein are all from the field of non-invasive optical biosensors. These devices have a wide range of applications, for example, measuring blood flow characteristics such as blood oxygen saturation, blood pressure, and cardiac output. Non-invasive optical biosensors are generally characterized as devices that pass light from a light source through the skin (i.e., non-invasive) into a blood perfused area of body tissue and then use a photodetector to sense the absorption of light in the tissue.

42. One common and well-understood non-invasive optical biosensor is a pulse oximeter, which is described in the '265 patent. Pulse oximeters have been known since at least the 1970's, with technology used in pulse oximeters dating back to the 1930's. APPLE-1019, p. 98. Pulse oximetry is a widely used method for monitoring arterial hemoglobin oxygen saturation (SpO<sub>2</sub>). *Id.*

## **VI. THE '265 patent**

### **A. Overview of the '265 patent**

43. The '265 patent generally relates to “noninvasive methods, devices, and systems for measuring a blood constituent or analyte ... or for measuring many other physiologically relevant patient characteristics.” APPLE-1001, 2:22-28.

44. In its background section, the '265 patent explains that “[t]he standard of care in caregiver environments includes patient monitoring through spectroscopic analysis using, for example, a pulse oximeter,” and that “[d]evices capable of spectroscopic analysis generally include a light source(s) transmitting optical radiation into or reflecting off a measurement site, such as, body tissue carrying pulsing blood.” *Id.*, 2:66-3:4. “After attenuation by tissue and fluids of the measurement site, a photo-detection device(s) detects the attenuated light and outputs a detector signal(s) responsive to the detected attenuated light.” *Id.*, 3:4-7. “A signal processing device(s)” then “process[es] the detector(s) signal(s) and outputs a measurement indicative of a blood constituent of interest, ... other physiological parameters, or other data or combinations of data useful in determining a state or trend of wellness of a patient.” *Id.*, 3:8-13.

45. In this way, the '265 patent confirms that prior art “devices capable of spectroscopic analysis” (“for example, a pulse oximeter”), generally included one or more light sources configured to emit light into user tissue, one or more detectors configured to detect light after attenuation by the user’s tissue and to output responsive signal(s), and one or more signal processors configured to

process signals and to output measurements of physiological parameters. *Id.*, 2:66-3:13.

46. In the '265 patent's system, "the detectors 106 can capture and measure light transmitted from the emitter 104 that has been attenuated or reflected from the tissue in the measurement site 102," and "[t]he detectors 106 can output a detector signal 107 responsive to the light captured or measured." *Id.*, 14:11-17. These signals can include, for instance, oxygenation and/or pulse rate information of the user. *Id.*, 2:28-30.

47. Referring further to FIG. 1 below, the '265 patent generally describes a system that "include[s] a sensor 101 (or multiple sensors) that is coupled to a processing device or physiological monitor 109," and where "the sensor 101 and the monitor 109 are integrated together into a single unit" or alternatively "separate from each other and communicate one with another in any suitable manner, such as via a wired or wireless connection." *Id.*, 11:56-62.

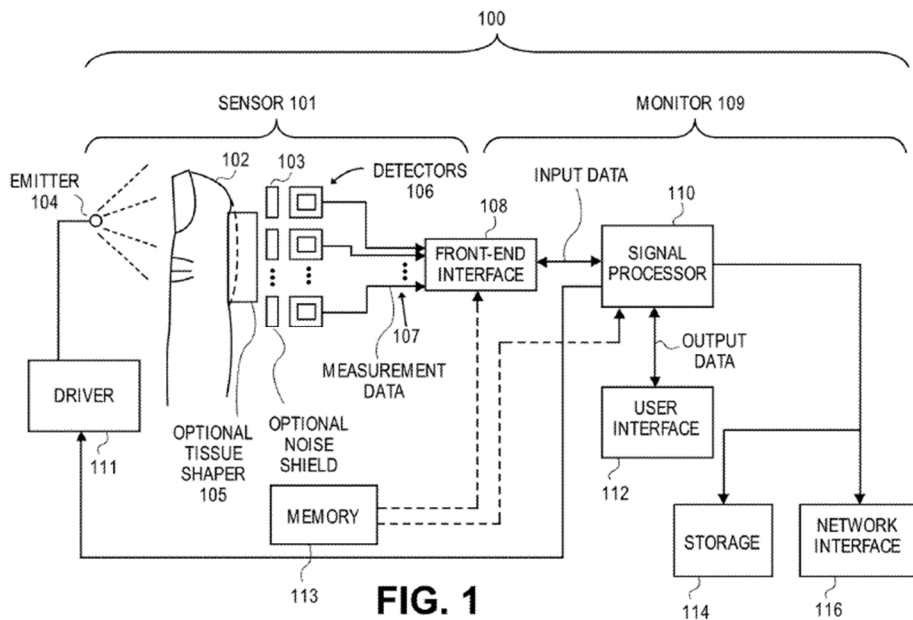

APPLE-1001, FIG. 1

48. Incidentally, while most of the specification and the drawings of the '265 patent are directed to a transmittance-type measurement device in which the emitter and the detector are positioned opposite each other relative to a measurement site (*e.g.*, opposite sides of a finger), the overall operating principle is similar in a reflectance-type device in which the emitter and the detector are positioned on the same side of the measurement site and the light from the emitter is “reflected” toward the detector. *Id.*, 14:12-15, 26:37-38.

49. I show below one example of the '265 patent's monitoring device, which is made up of a sensor portion (colored blue) and a monitor portion (colored green):

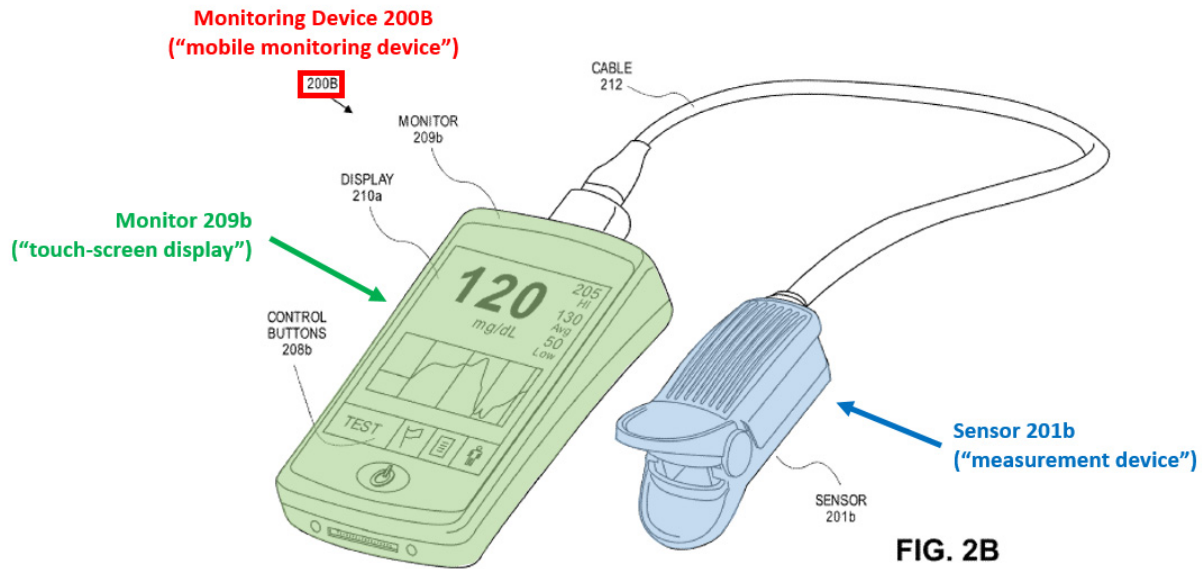

APPLE-1001, FIG. 2B

50. Shown below is an example sensor and sensor housing as described in the '265 patent. Here, you can see that a plurality of detectors are disposed within a housing and further covered by a transparent cover, which the '265 patent refers to as a light permeable cover. See APPLE-1001, 36:38-49. The '265 patent also describes that this cover can have a protrusion and notes that such a protrusion can help “conform the measurement site into a rounded surface, such as, for example, a concave or convex surface.” *Id.*, 8:14-16. The '265 patent also mentions that, in some cases, the protrusion may be implemented “as a lens to refract the rays” passing through it. *Id.*, 36:19-30.



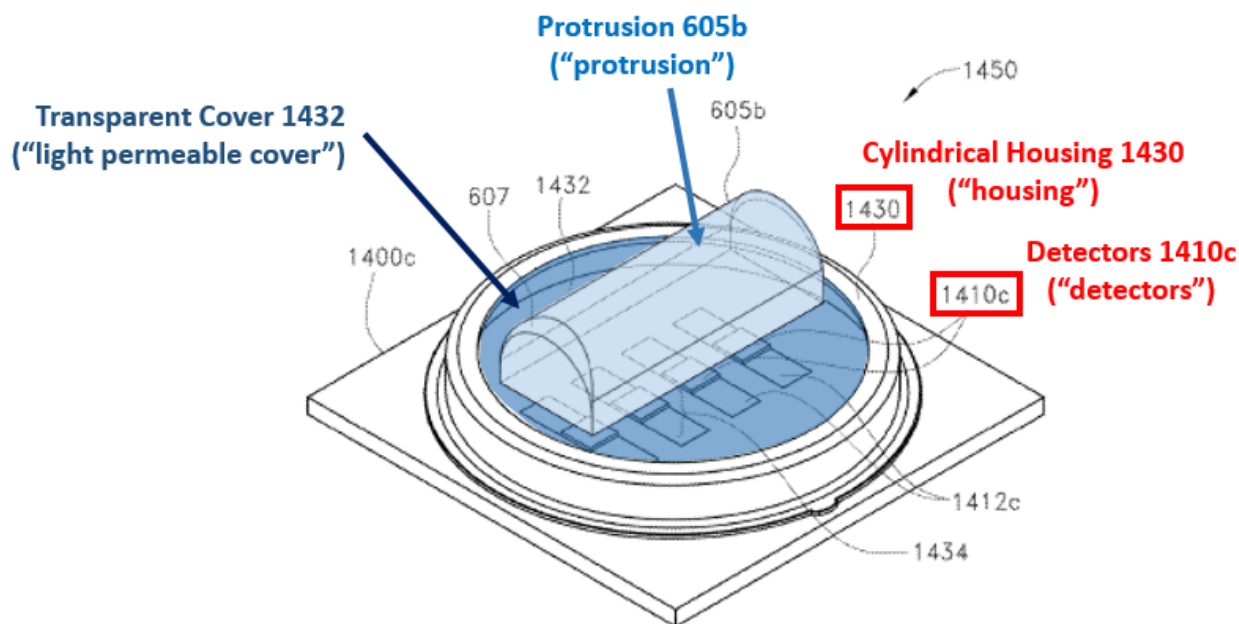

**FIG. 14D**

APPLE-1001, FIG. 14D

51. As explained below with respect to the applied prior art, noninvasive physiological sensors commonly included these features by the '265 patent's Critical Date, and a sensor including each of the '265 patent's claimed features would have been obvious to one of ordinary skill. APPLE-1001, 44:66-47:20.

52. I understand that no office actions were issued during the prosecution of the application from which the '265 patent issued. *See generally* APPLE-1002.

## VII. SUMMARY OF THE PRIOR ART

### A. Overview of Aizawa

53. Aizawa relates to a “pulse wave sensor...detecting light output from a light emitting diode and reflected from the artery of a wrist of a subject.” APPLE-1006, Abstract. Similar to the '265 patent, Aizawa detects light emitted from an emitter to obtain pulse information from a user. *Id.*

54. Referring to the annotated drawings below, Aizawa’s sensor device detects a user’s pulse wave by using an emitter (LED 21, colored green) to emit light that is picked up by detectors (photodetectors 22, colored red) that are arranged around the emitter. APPLE-1006, [0023]. While this particular arrangement can work with a wide range of wavelengths, Aizawa’s example mentions that “[n]ear infrared radiation output toward the wrist 10 from the light emitting diode 21 is reflected by a red corpuscle running through the artery 11 of the wrist 10 and this reflected light is detected by the plurality of photodetectors 22 so as to detect a pulse wave.” *Id.*, [0027].

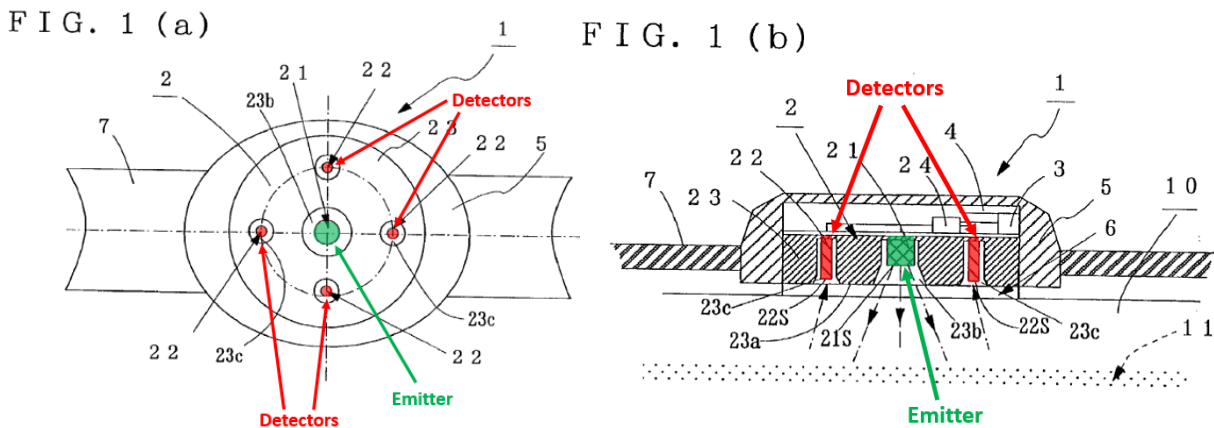

APPLE-1006, FIGS. 1(a) and 1(b)

55. Aizawa also teaches, in addition to the configuration above where four detectors are shown, that more detectors may be used to “further improve detection efficiency.” *Id.*, [0032]. Also, in addition to the configuration above where just a single emitter is shown, Aizawa teaches that more emitters may be used as needed, for instance by surrounding a centrally located detector by a plurality of emitters. *Id.*, [0033].

56. Referring to the annotated drawing below, Aizawa also describes the use of an “acrylic transparent plate 6” (colored blue)—which corresponds to the ’265 patent’s light permeable cover—that is mounted at a wrist-facing detection face 23a.

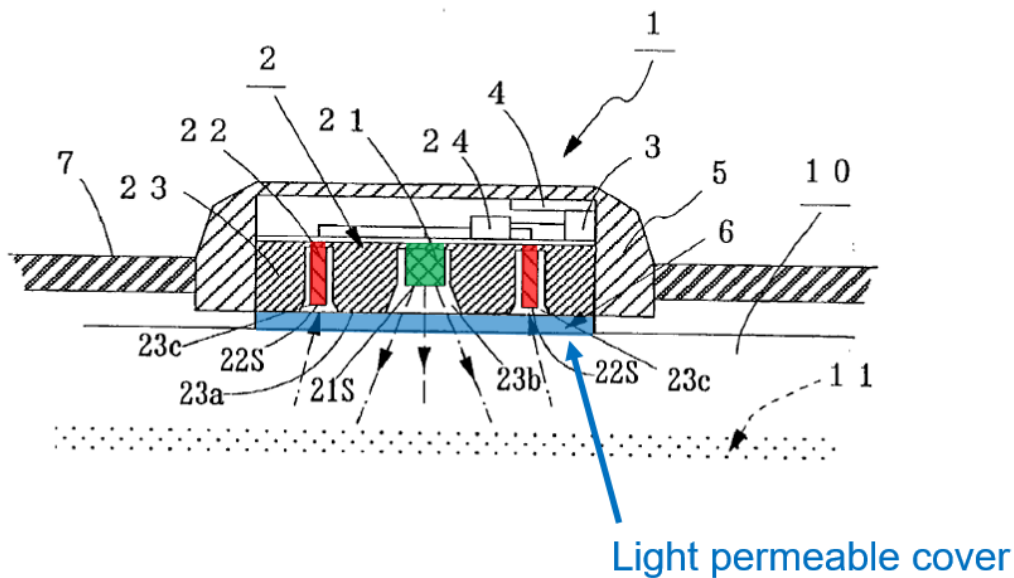

APPLE-1006, FIG. 1(b)

57. This transparent plate provides a light permeable cover that covers and protects the emitter/detector assembly while also promoting improved adhesion

between the detector and the wrist to “further improv[e] the detection efficiency of a pulse wave.” *Id.*, [0030].

58. Referring to FIG. 2 below, the sensor of Aizawa is designed to be worn on the wrist as a wristwatch-type device. *Id.*, [0026]. The various emitters/detectors of Aizawa are housed within a circular housing structure, which has been colored in red below.

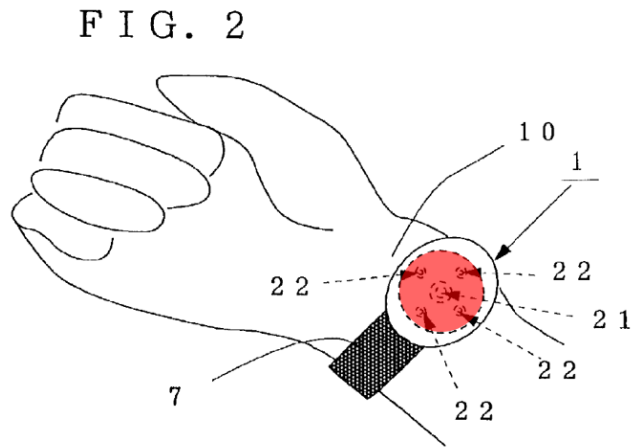

APPLE-1006, FIG. 2.

### B. Overview of Inokawa

59. Inokawa is generally directed to an “optical vital sensor is a pulse sensor 1 that is able to sense the pulse, etc. by being attached, for example, to a person’s finger or wrist.” APPLE-1008, [0056]. For example, Inokawa teaches attaching such a sensor to the user’s wrist using a wristband 5. *Id.*, [0057].

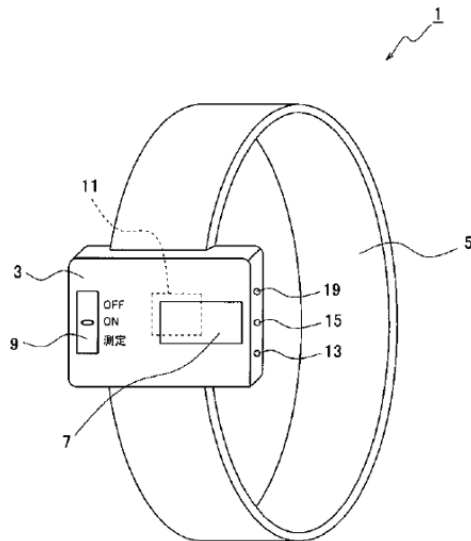

APPLE-1008, FIG. 1

60. As shown in annotated FIG. 2 below, Inokawa sense the user's pulse by using a detector (photodiode detector 25, colored red) that receives "light reflected off of the body (i.e. change in the amount of hemoglobin in the capillary artery)." *Id.*, [0058]. As for its emitters, as shown below, Inokawa teaches that a "sensor-side light-emitting means of various kinds, such as an infrared LED or a green LED" may be used and further that "work can be divided between." *Id.*, [0014]. In other words, as illustrated below, one emitter (LED 21, colored green) may be used to emit light that is used for sensing the user's pulse while the other emitter (LED 23, colored purple) may be used to emit light of a different wavelength that is used to sense the user's body motion. *Id.*, [0058]-[0059].

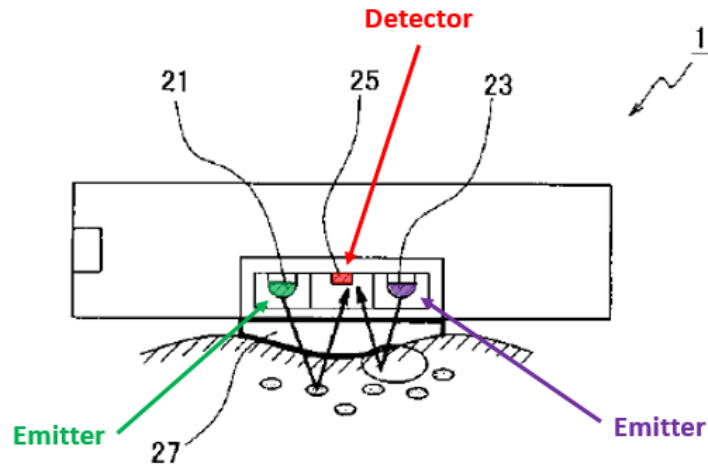

APPLE-1008, FIG. 2

61. Similar to the '265 patent's light permeable cover, Inokawa also teaches a lens 27 that can be "placed on the surface of the sensor-side light-emitting means" to "make[] it possible to increase the light-gathering ability of the LED as well as to protect the LED or PD." *Id.*, [0015], [0058]. As I will further explain below in my analysis of claim 1, this lens corresponds well, both structurally and functionally, to the light permeable cover comprising a protrusion as claimed in the '265 patent. *Id.*

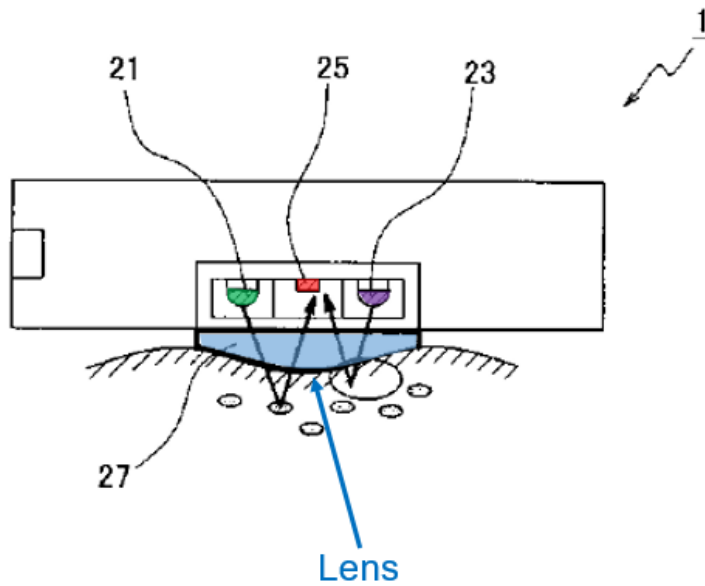

APPLE-1008, FIG. 2

62. Lastly, Inokawa teaches the use of a base device in conjunction with its sensor. For example, as shown below, Inokawa teaches that its wrist sensor (colored red) may be mounted onto a base device (colored blue blue) that serves as a “charger with communication functionality.” *Id.*, [0060].

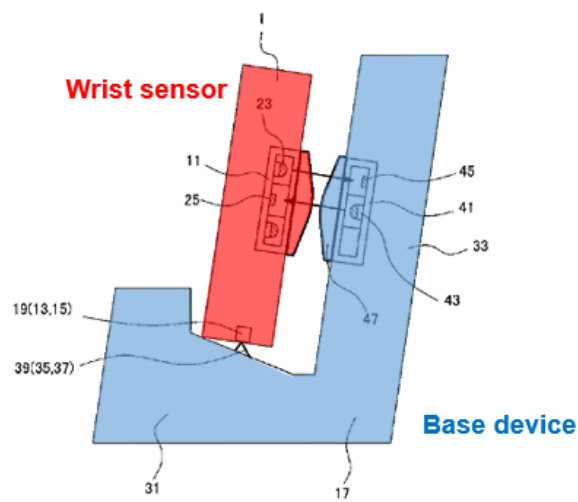

APPLE-1008, FIG. 3

63. By mounting the sensor to the base in this manner, Inokawa teaches that vital sign information can be exchanged between them by utilizing the same emitters/detectors that are used to measure pulse and body motion. *Id.*, [0066]-[0077], [0109]-[0111]. Fig. 7 of Inokawa below shows how vital sign information from the sensor (red) can be transmitted to a PC (purple) via the base device (blue).

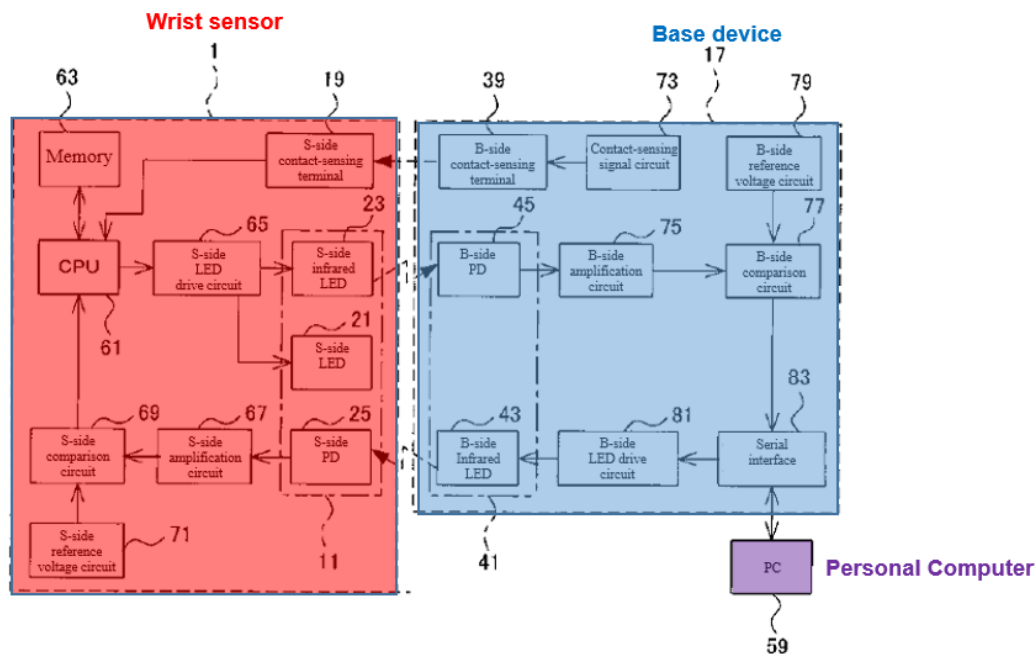

APPLE-1008, FIG. 7, [0066]-[0077]

### C. Overview of Ohsaki

64. Ohsaki discloses a wrist-worn “pulse wave sensor” having a “light emitting element” and a “light receiving element.” APPLE-1014, [0016], [0017]. Ohsaki’s sensor addresses problems such as user discomfort and movement of the sensor by using a “translucent board” with a convex surface that is “in intimate contact with



the surface of the user's skin" to prevent slippage. *Id.*, [0009]-[0010]. Because the intensity of the light received by the detecting element "largely varies depending on the shift amount," or amount of movement of the detecting element, Ohsaki's convex surface reduces the "amount of reflected light which is emitted" from the LED and reaches the detecting element "by being reflected by the surface of the user's skin." *Id.*, [0025].

FIG. 2

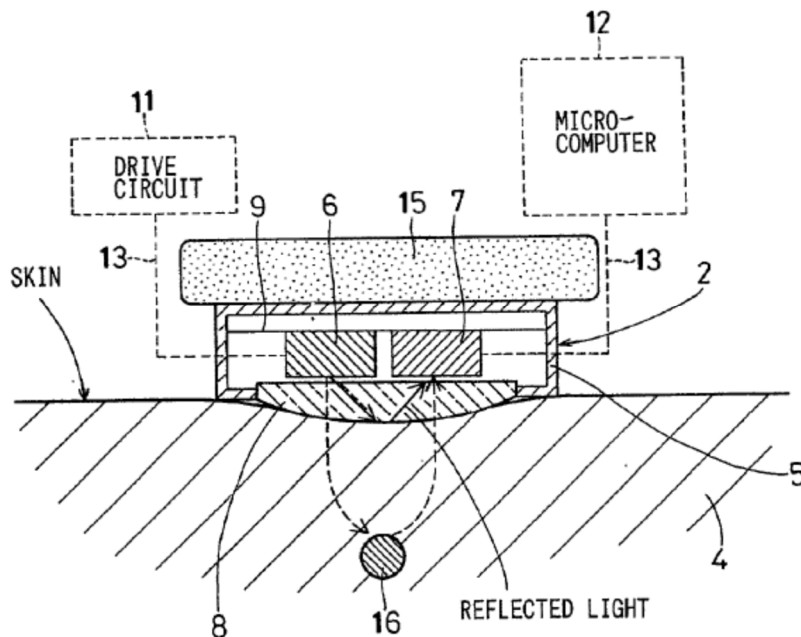

APPLE-1014, FIG. 2

65. As shown below, pulse sensor of Ohsaki is designed to be "worn on the back side of the user's wrist 4 ... in the similar manner as a wristwatch is normally worn," *Id.*, [0016]. Both Aizawa and Inokawa, as noted above, are also designed

to be worn on the wrist in a similar manner. APPLE-1006, [0026]; APPLE-1008, [0057].

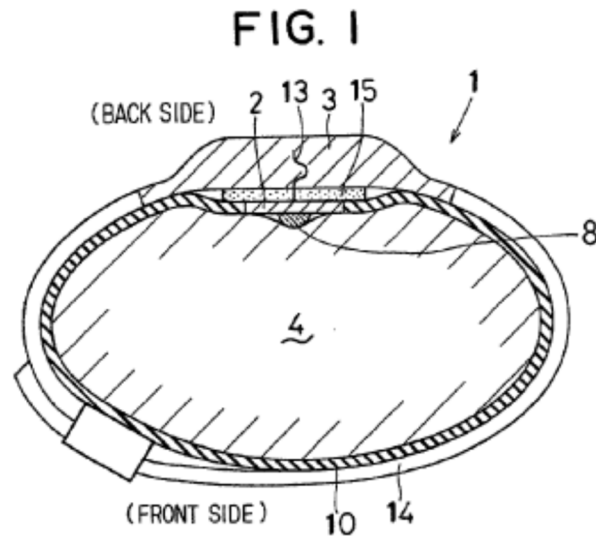

APPLE-1014, FIG. 1

#### D. Overview of Mendelson-1988

66. Mendelson-1988 describes an “optical reflectance sensor suitable for noninvasive monitoring of arterial hemoglobin oxygen saturation with a pulse oximeter.” APPLE-1015, Abstract. As shown below in FIG. 2(A), the pulse oximeter of Mendelson-1988 includes two red and two infrared LED emitters at the center that are surrounded by six photodiode detectors. *Id.*, 168.

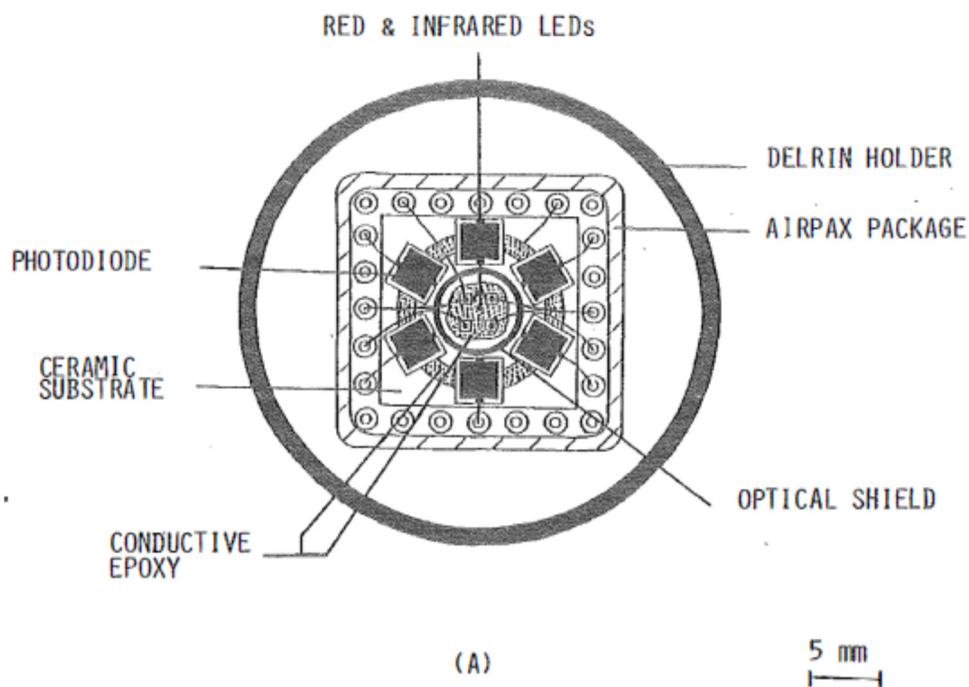

APPLE-1025, FIG. 2(A)

67. Mendelson-1988 mentions that a user's forehead provides a good location for placing its sensor because of the region's alleged "relatively large reflectance photoplethysmographic signals," but Mendelson-1988's sensor can certainly be used at other locations as well based on its recognition that "several locations on the body (*e.g.*, forearm, chest, and back)" also allowed the reflectance photoplethysmograms to be detected. *Id.*, 173. Further support for the wider applicability of Mendelson-1988 beyond forehead locations is provided by subsequent work by the same author (Mendelsohn) that recognize, for instance, wrist and forehead regions as convenient alternative locations for a reflectance-type pulse oximeter. *See, e.g.*, APPLE-1024, 3017.

68. In more detail, the sensor of Mendelson-1988, shown below, includes a housing (colored red) that encases the optical components as well as an optically clear adhesive/epoxy (colored blue) that encapsulates such components within the housing and, thus, acts as a light permeable cover for the detectors. APPLE-1015, 168.

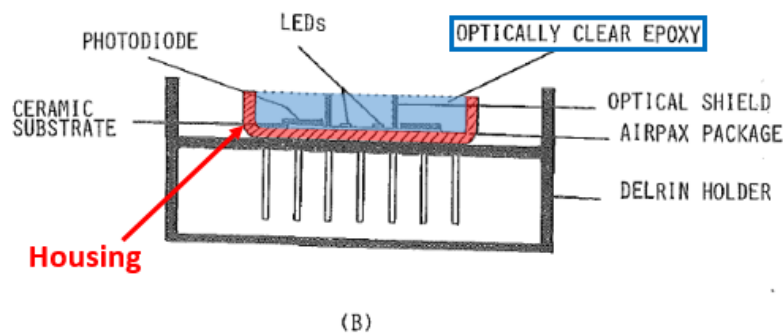

APPLE-1015, FIG. 2(b)

### E. Overview of Mendelson-2006

69. Mendelson-2006 details the structure and testing of a “wireless wearable pulse oximeter” system. APPLE-1016, Abstract. Mendelson-2006’s system uses a pulse oximetry, a “widely accepted method that is used for noninvasive monitoring of SpO<sub>2</sub> and [heart rate],” to monitor a subject’s physiological signals. *Id.*, 912. By wirelessly transmitting the collected data wirelessly, Mendelson-2006’s system provides “numerous advantages,” including the ability to determine the condition of a subject “remotely” without requiring the healthcare provider to be physically present. *Id.*

70. The system includes a sensor module, a receiver module, and a PDA. *Id.*,

913. As shown in FIGS. 1 and 2 of Mendelson-2006, the sensor module includes

an “optical reflectance transducer” having two LEDs and a photodiode that

“receives and processes the [photoplethysmographic (PPG)] signals” and transmits

these signals wirelessly to the PDA through the receiver module. *Id.*; FIGS. 1 and

2 (reproduced below).

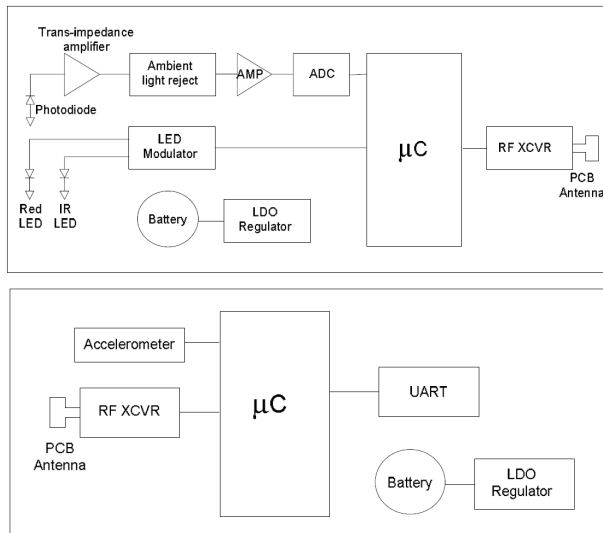
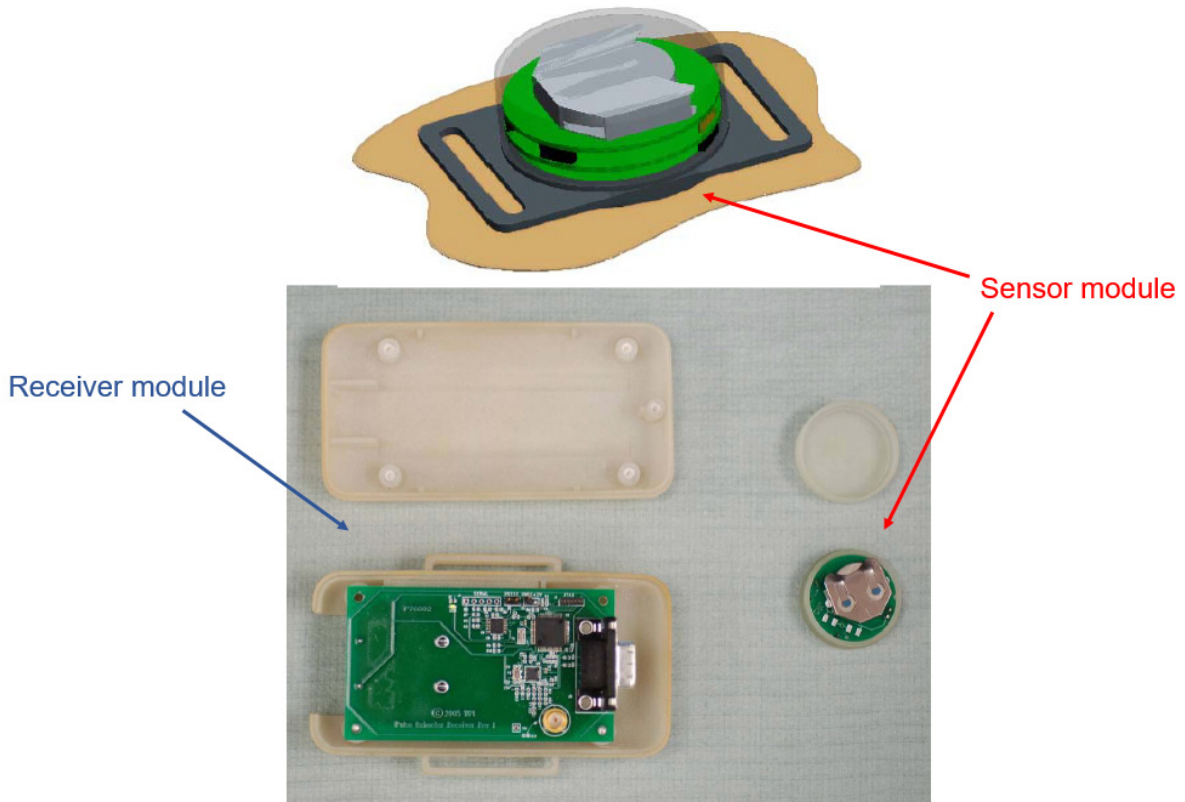

Fig. 2. System block diagram of the wearable, wireless, pulse oximeter. Sensor Module (top), Receiver Module (bottom).

APPLE-1016, FIG. 1 (top) and FIG. 2 (bottom)

71. Physiological data received by the receiver module can further be wirelessly transmitted “to a PC” for enhanced monitoring of the sensed physiological parameters, such as by medics. *Id.*, 913. Shown below is an example PC (“iPAQ Pocket PC”), or a PDA, that can be used for receiving data from the receiver module as described above. In this instance, HP’s iPAQ h4150, “provides a low-cost *touch screen interface*” such that “data from the wireless-enabled PDA can also be downloaded or streamed to a remote base station via Bluetooth or other wireless communication protocols.” *Id.*, 914 (emphasis added).



APPLE-1015, FIG. 3

## F. Overview of Beyer, Jr.

72. Beyer, Jr. is generally directed to a “Cellular Phone/PDA Communication System” and describes improved communications that may be achieved using a “conventional cellular phone PDA.” APPLE-1019, Title, Abstract. In more detail, Beyer, Jr. teaches “cellular PDA/GPS phones” that allow users “to rapidly call and communicate data among the users by touching display screen symbols and to enable the users to easily access data concerning other users and other database information.” *Id.*, 1:6-15. A side-by-side comparison of Beyer, Jr.’s PDA and Mendelson-2006’s PDA below show a highly similar overall design and form factor.

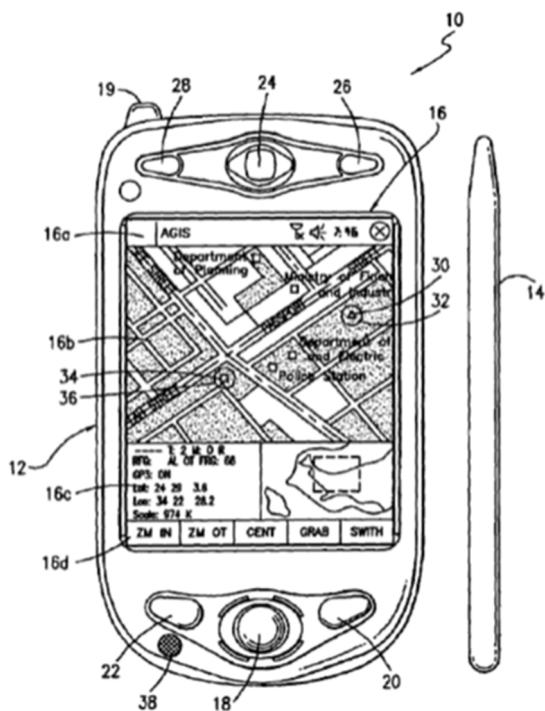



APPLE-1019, FIG. 1 (left); APPLE-1014, FIG. 3 (right)

**VIII. GROUND 1A – Claims 1-4, 6-14, 16, 17, 19-23, and 26-29 Are Rendered Obvious by Aizawa in view of Inokawa**

**A. Claim 1**

**[1pre] A noninvasive optical physiological measurement device adapted to be worn by a wearer, the noninvasive optical physiological measurement device providing an indication of a physiological parameter of the wearer comprising:**

73. Aizawa a pulse sensor that is designed to “detect[] the pulse wave of a subject from light reflected from a red corpuscle in the artery of a wrist of the subject by irradiating the artery of the wrist.” APPLE-1006, [0002]. Thus, the sensor of Aizawa is a noninvasive optical physiological measurement device and provides an indication of a physiological parameter, namely pulse. *Id.* As shown below, Aizawa’s sensor is adapted to be worn by the user by being attached to the user’s wrist. *Id.*, [0026].

F I G . 2

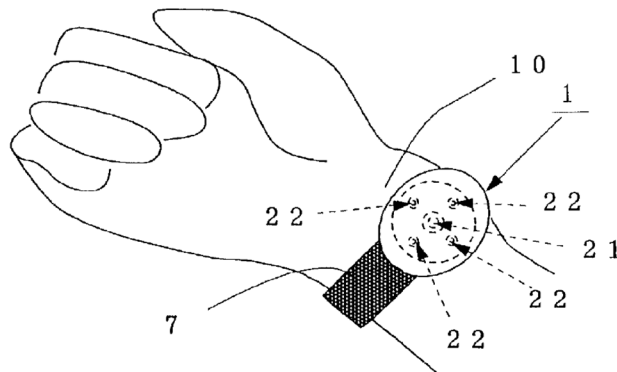

APPLE-1006, FIG. 2

**[1a] a plurality of emitters of different wavelengths;**

74. As noted above, Aizawa teaches a pulse wave sensor having multiple detectors disposed circularly around an emitter. APPLE-1006, [0023]. As also noted, Aizawa considers the use of multiple emitters but does not expressly talk about using multiple emitters at different wavelengths. *Id.*, [0033].

75. Here, I note that Inokawa teaches the use of two different types of emitters “such as an infrared LED or a green LED” and further teaches that “work can be divided between the various means, with an infrared LED used to detect vital signs and transmit vital sign information, and a green LED used to detect pulse.”

APPLE-1008, [0014], [0044], [0058], [0059]. As shown below, Inokawa teaches use of a first emitter (LED 21, colored green) and a second emitter (LED 23, colored purple). *Id.*, [0058], [0059].

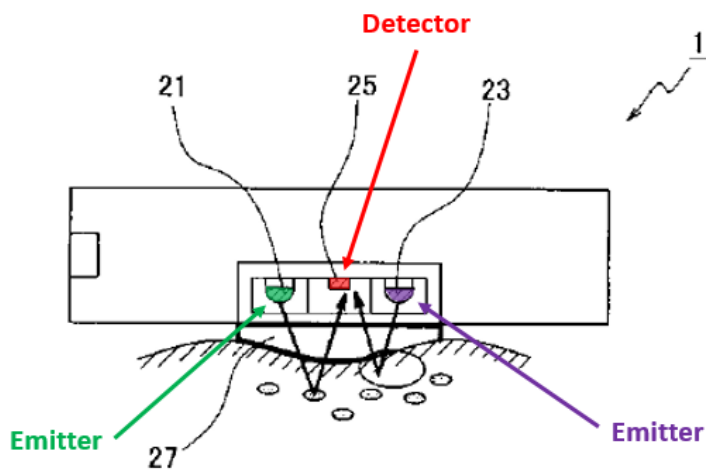

APPLE-1008, FIG. 2

76. A POSITA in possession of both Aizawa and Inokawa would have realized that Inokawa's teachings concerning the use of two different emitters operating at different wavelengths would be applicable to Aizawa as well able to yield similar benefits. For example, Aizawa only mentions using a single wavelength of light, but Inokawa teaches the benefits of dividing the role of a single LED into two different LEDs "with an infrared LED used to detect vital signs and transmit vital sign information, and a green LED used to detect pulse." APPLE-1008, [0014], [0044], [0058], [0059].

77. Thus, a POSITA would have recognized that providing an additional emitter of a different wavelength to Aizawa, as per Inokawa, would enable Aizawa's device to, for instance, (1) use the existing infrared LED to detect body motion and (2) use the added green LED to detect pulse. *Id.*, [0059]. While it's possible that adding more emitters to Aizawa may lead to increased power consumption, a POSITA seeking to improve detection performance would have nevertheless looked to Inokawa's multi-emitter setup to achieve enhanced performance benefits. *Id.* Indeed, various other prior art pulse sensing devices teach, similar to Inokawa, using a first LED emitting at below 600 nm (*e.g.*, green) to measure blood flow and a second LED emitting at above 600 nm (*e.g.*, infrared) to measure body movement. APPLE-1010, 8:45-50. The added ability to measure body movement in this manner will allow for a more reliable measurement that can, for instance,

take into account and correct for inaccurate readings related to body movement.

*Id.* For instance, the signal component corresponding to body movement can be subtracted from the pulse signal to help better isolate the desired pulse data. *Id.*

Thus, applying the teachings of Inokawa, a POSITA would have been motivated and found it obvious to divide the single emitter of Aizawa, into two emitters

operating at two different wavelengths, as demonstrated below, to be able to detect both pulse and body movement signals.

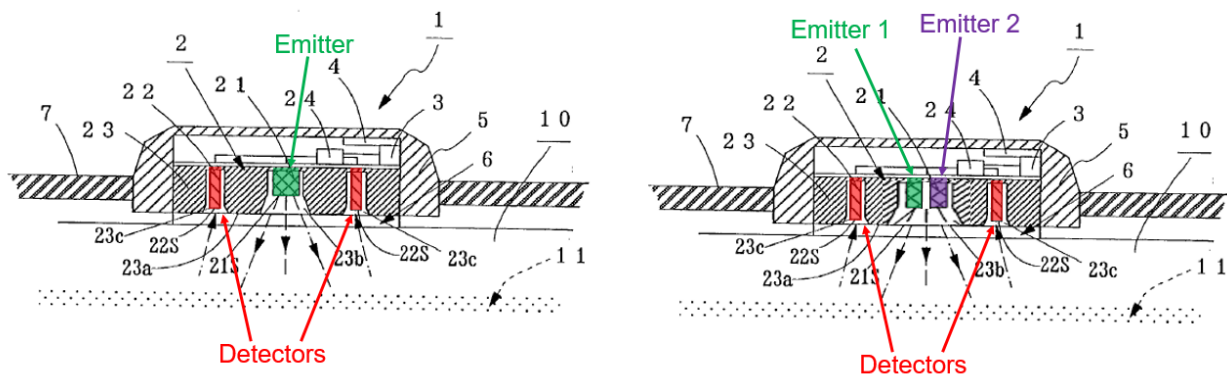

APPLE-1006, FIG. 1(b)

78. More specifically, one of ordinary skill would have replaced Aizawa's LED 21 with two LEDs, each emitting a different wavelength. As suggested by

Inokawa, one of ordinary skill would have recognized that this would improve Aizawa's sensor by enabling it to account for motion load through use of the

second LED, by detecting and recording body motion in addition to blood flow.

APPLE-1008, [0006], [0028], [0035]. Because, Aizawa already contemplates

adding additional emitters, a POSITA would have known how to make the changes

needed, for example concerning circuitry, to add another LED in this manner.

APPLE-1006, [0032]. While the exemplary drawings I've provided above show two smaller emitters replacing a larger emitter, which is simply a matter of design choice to a POSITA in circuit design and assembly, a similar effect could be achieved by simply enlarging the emitter cavity and including two larger emitters, which is again a simple matter of design choice.

79. Such a modification would have amounted to nothing more than the use of a known technique to improve similar devices in the same way, and combining prior art elements according to known methods to yield predictable results. Indeed, a POSITA would have recognized that applying Inokawa's teachings about two emitters having different wavelengths to Aizawa's sensor would have led to predictable results without significantly altering or hindering the functions performed by Aizawa's sensor. That is, a POSITA would have been motivated to provide the well-known feature of providing multiple emitters to a pulse sensor to achieve the predictable benefits that Inokawa's arrangement provides.

80. In addition to the rationale provided above, Inokawa provides an additional, or alternative, reason to add another emitter to Aizawa.

81. First, I note that Aizawa contemplates uploading data from its wrist sensor to an external base device but does not go into details about how such data transmission would be implemented. APPLE-1006, [0015], [0023], [0035]. Here,

a POSITA would have been able to fill this gap by looking to Inokawa, which, as shown below, teaches a base device 17 (colored blue) that both charges and receives data from the pulse sensor 1 (colored red). APPLE-1008, [0060].

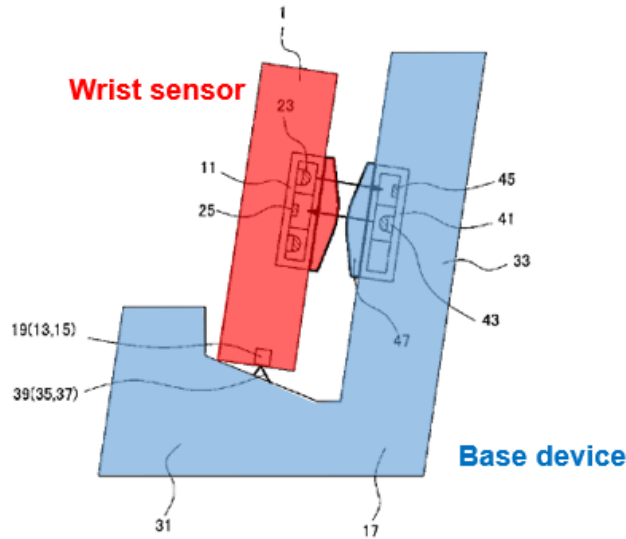

APPLE-1008, FIG. 3

82. Inokawa further teaches that, by using the sensor’s infrared emitter to transmit data, “it is not necessary to use a wireless communication circuit or to establish connections via communication cable, which makes it possible to easily transmit vital sign information with few malfunctions and with a simple structure.” APPLE-1008, [0007]. In view of such teaching, a POSITA would have been motivated and found it obvious and straightforward to incorporate Inokawa’s base device and LED-based data transmission into Aizawa’s sensor to, for instance, “make[] it possible to transmit vital sign information to the base device 17 accurately, easily, and without malfunction.” *Id.*, [0077]. A POSITA would have

also recognized that adding Inokawa's base device and LED-based data transmission scheme to Aizawa would allow Aizawa to upload data from its sensor without having to use a separate cable and without having to incorporate a separate RF circuit into Aizawa's wrist sensor. APPLE-1008, [0007].

83. Here, I note that Inokawa's sensor is able to transmit data using only a single LED, for example operating at infrared wavelength. APPLE-1008, [0062].

However, as shown below, Inokawa also teaches that it's possible to use two different LEDs operating at different wavelengths to improve data transmission accuracy, namely by using a second LED operating at green wavelength, for instance, to transmit checksum information such that "the accuracy of data can be increased." *Id.*, [0111], [0044], [0048].

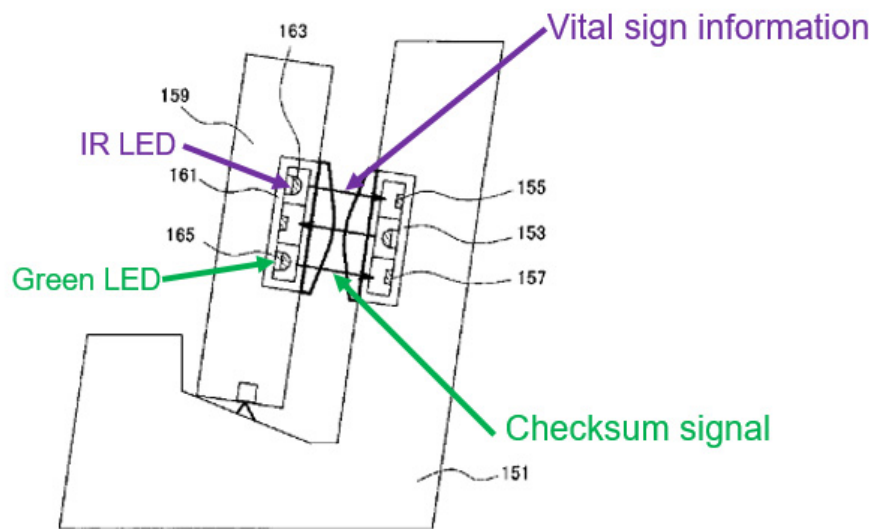

APPLE-1008, FIG. 19

84. Accordingly, a POSITA would have found it obvious to supplement Aizawa's IR LED with an additional green LED, as per Inokawa, improve accuracy of data transmission from its sensor.

85. Indeed, a POSITA would have found it obvious to modify Aizawa with Inokawa in this manner because doing so entails the use of known solutions (*i.e.*, using a dual-LED system to more accurately transmit pulse data from a sensor to a base device) to improve similar systems and methods in the same way. For instance, a POSITA would have recognized that applying Inokawa's base device and dual-LED-based data transmission to Aizawa's sensor would have led to the predictable result of more accurate and convenient data transmission without significantly altering or hindering the functions performed by Aizawa's sensor. As such, a POSITA would have had a reasonable expectation of success in making this modification, and would have reasonably expected to reap benefits of simple and accurate data transmission. Indeed, it was common practice in the pulse oximeter field to centrally locate multiple emitters of different wavelengths, for example as further demonstrated by Mendelson-1988. APPLE-1015, 168; FIG. 2(A).

86. Thus, for reasons provided above, a POSITA would have found it obvious to split the single emitter of Aizawa into two emitters as in Inokawa in order to (i) acquire body motion information for improved pulse detection and/or (ii) more



reliably transmit information from the sensor to a base device with less error.

APPLE-1008, [0007], [0014], [0044], [0048], [0058], [0058], [0059], [0060], [0062], [0077], [0111].

**[1b] a housing having a surface and a circular wall protruding from the surface;**

87. Aizawa teaches a “a holder 23 for storing the above light emitting diode 21 and the photodetectors 22.” APPLE-1006, [0023], [0024]. In addition to the holder 23, as illustrated below, Aizawa also provides a flat surface (colored brown) that supports the holder 23. *Id.*

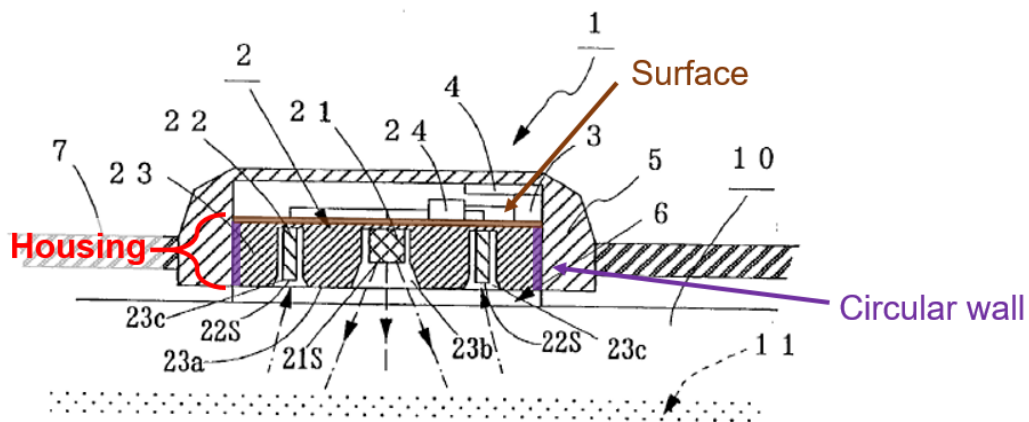

APPLE-1006, FIG. 1(b)

88. Thus, the holder and the flat surface together provide the housing element as required by this claim. Moreover, referring to FIGS. 1(b) above and (1a) below, the outer periphery of Aizawa’s holder 23 provides a circular wall (colored purple) that protrudes from the surface.

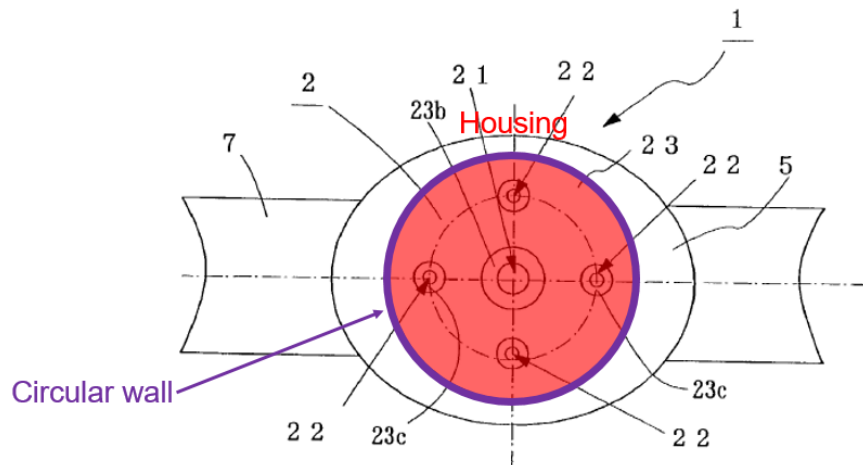

Apple-1006, FIG. 1(a)

**[1c] at least four detectors arranged on the surface and spaced apart from each other, the at least four detectors configured to output one or more signals responsive to light from the one or more light emitters attenuated by body tissue, the one or more signals indicative of a physiological parameter of the wearer; and**

89. As illustrated below, Aizawa teaches “four photodetectors 22 disposed around the light emitting diode 21 symmetrically on a circle concentric to the light emitting diode 21.” APPLE-1006, [0029], [0024], [0032]. These four detectors are, as seen below, spaced apart from each other by being arranged symmetrically in a circular pattern. *Id.*

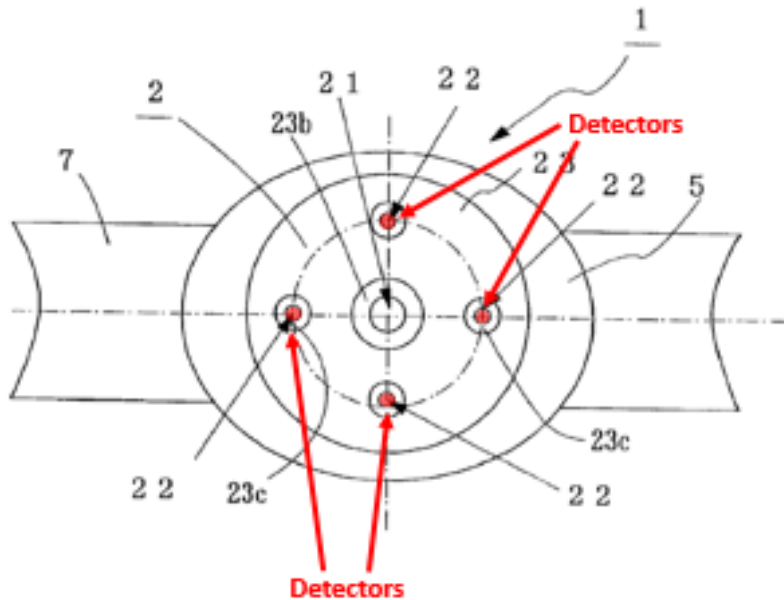

APPLE-1006, FIG. 1(a)

90. Moreover, these four detectors are arranged *on the surface* of the housing as identified above for element [1c]. In particular, as shown below, the detectors are positioned within the holder 23 and are further connected, through the surface (shown in brown), to a drive circuit 24 on the other side of the housing. *Id.*, [0023]. A POSITA would have understood that circuit 24 and other wires/electronics are connected to the detectors *through* the surface, and, therefore, the surface provides physical support to the detectors. *Id.* Indeed, it is well-known to mount electronic components, such as photodiodes and LEDs, to a flat surface such as a ceramic substrate or a circuit board to provide both mechanical and electrical coupling. [0017], FIG. 2; APPLE-1015, 168, FIG. 2B.

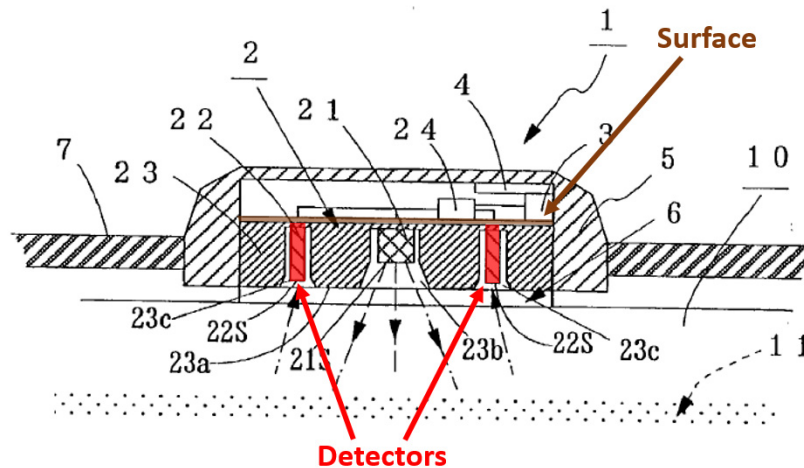

APPLE-1006, FIG. 1(b)

91. Regarding the signals that are output by Aizawa’s detectors, Aizawa’s photodetectors 22 are designed to detect light that is “reflected by a red corpuscle running through the artery 11 of the wrist 10 ... so as to detect a pulse wave.”

APPLE-1006, [0027]. Aizawa subsequently “detect[s] a pulse wave by amplifying the outputs of the photodetectors 22.” *Id.*, [0023]. For example, Aizawa’s detectors output “waveform of a pulse wave,” and this output is amplified and converted into a digital signal to compute the pulse rate. *Id.*, [0028]. Thus, the detectors of Aizawa “output one or more signals responsive to light from the one or more light emitters attenuated by body tissue” and this signal is further “indicative of a physiological parameter of the wearer.”

**[1d] a light permeable cover arranged above at least a portion of the housing, the light permeable cover comprising a protrusion arranged to cover the at least four detectors.**

92. As explained above and shown below, Aizawa teaches a light permeable cover in the form of an acrylic transparent plate 6 (colored blue) that is mounted at the detection face 23a over at least a portion of the housing to cover the at least four detectors (colored red). APPLE-1006, [0023].

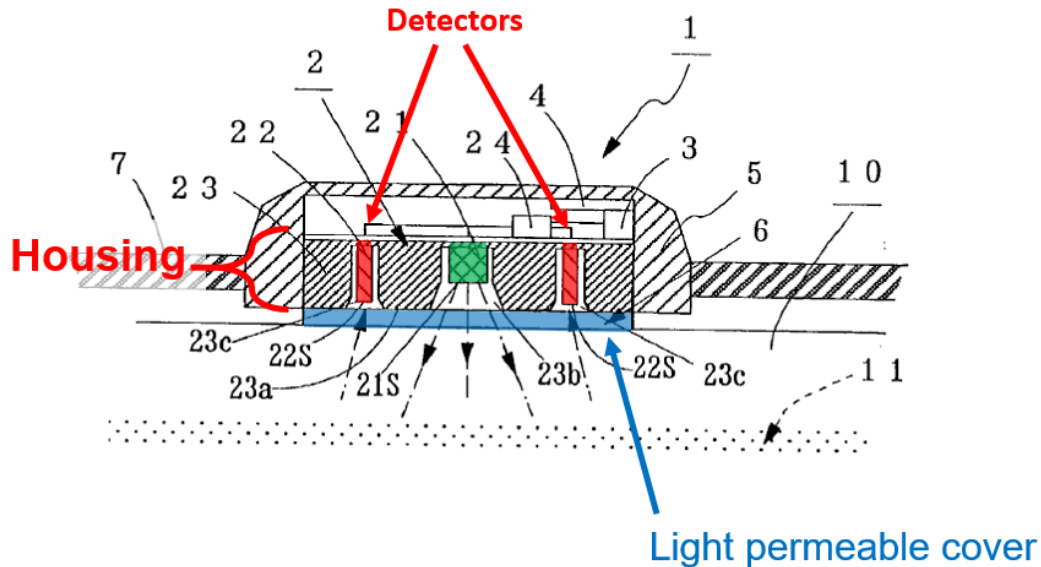

APPLE-1006, FIG. 1(b) (annotated), [0023]

93. However, the acrylic plate of Aizawa is flat and is not described as including a protrusion.

94. Additionally, a POSITA would have been motivated and known how to modify the flat shape of Aizawa's acrylic plate to achieve a particular, desired objective. For example, Aizawa teaches that its light permeable cover (*i.e.*, acrylic transparent plate) helps improve "detection efficiency," but does not otherwise provide more details about how, for instance based on its shape or material properties, such an effect may be achieved. APPLE-1006, [0030]. But a POSITA

would have readily recognized that the shape of Aizawa's plate could be modified based on well-known techniques to help achieve Aizawa's objective of improving detection efficiency. APPLE-1006, [0013], [0030], [0032]; APPLE-1009 at 3:46-51.

95. As one example, a POSITA would have been able to look to Inokawa to enhance light collection efficiency, in particular by modifying the light permeable cover of Aizawa to include a convex protrusion that acts as a lens, as per Inokawa. APPLE-1008, FIG. 2. As illustrated below, Inokawa teaches a side lens 27 (colored blue) that is positioned between a pulse sensor and the user's skin. *Id.*

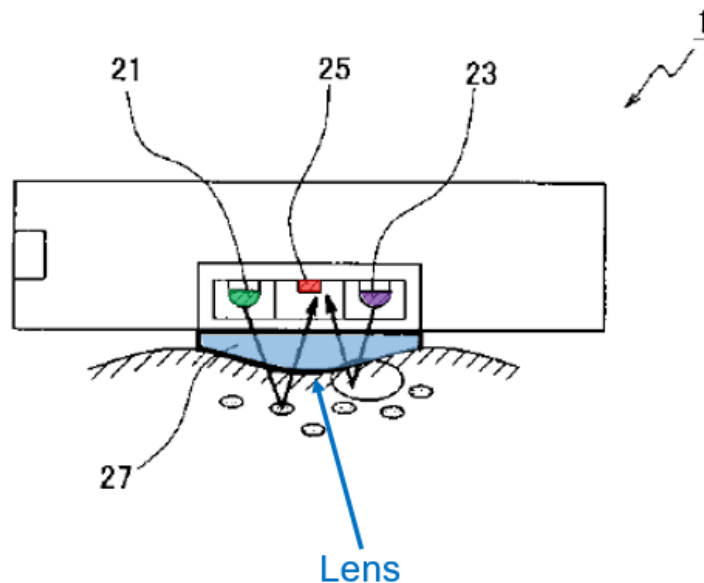

APPLE-1008, FIG. 2

96. Inokawa teaches that the “lens makes it possible to increase the light-gathering ability of the LED.” *Id.*, [0015]. Thus, a POSITA would have sought to incorporate a convex, lens-like shape as in Inokawa into Aizawa's acrylic plate to

thereby increase light collection efficiency, in turn leading to an enhanced signal-to-noise ratio and ultimately more reliable pulse wave detection. The lens shape of Inokawa can provide this benefit by refracting and concentrating the light coming in through Aizawa's acrylic plate after being reflected by the blood.

97. In more detail, a POSITA would have found it obvious to combine the teachings of Aizawa and Inokawa such that the flat cover (left) of Aizawa is modified to include a lens/protrusion (right) as per Inokawa in order to "increase the light-gathering ability." APPLE-1008, [0015]. Indeed, by positioning a lens above the optical components of Aizawa, as shown below, the modified cover will allow more light to be gathered and refracted toward the light receiving cavities of Aizawa, thereby further increasing the light-gathering ability of Aizawa beyond what is achieved through the tapered cavities. APPLE-1006, [0012], [0024].

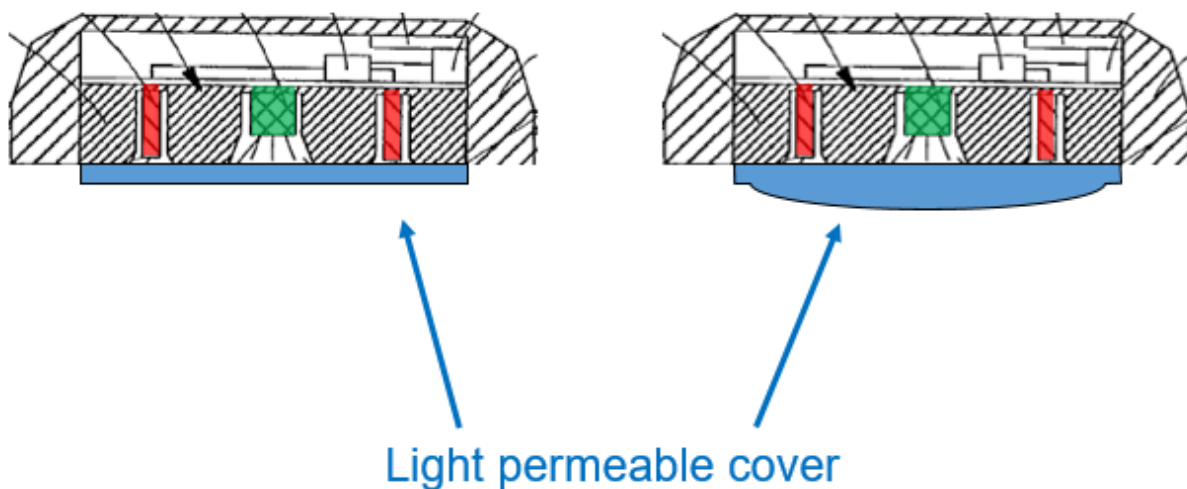

APPLE-1006, FIG. 1(b)

98. A POSITA would have further understood *how* to incorporate the shape of Inokawa’s cover into Aizawa’s cover, and further would have expected such a modification to succeed given the high degree of overlap between the two references. For example, as shown below, Inokawa teaches that its light permeable cover can be flat (left) so that “the surface is less prone to scratches,” or alternatively be in the form of a lens (right) to “increase the light-gathering ability of the LED.” APPLE-1008, [0015], [0016]. That is, depending on the desired objective of the user (*e.g.*, less scratches or improved light-gathering), the shape of the cover can be readily modified. Moreover, by choosing the material of the protrusion to be scratch-resistant, such as glass, it would have been obvious for a POSITA to achieve both benefits at once.

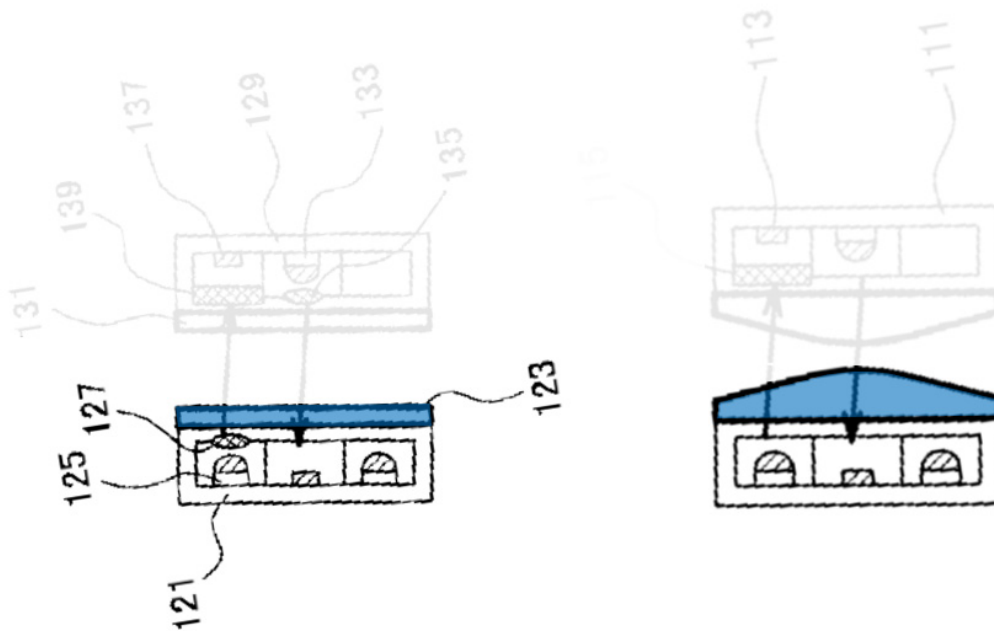

APPLE-1008, FIG. 17 (left), FIG. 16 (right)



99. A POSITA would have further recognized that the acrylic material used to make Aizawa's acrylic transparent plate 6 can be easily formed to include a lens. *See* APPLE-1009 at 3:46-51, FIG. 1; APPLE-1023, FIG. 6, [0022], [0032], [0035]. Indeed, many prior art references of this period, such as Nishikawa (shown below) demonstrate exactly how such a lens shape may be incorporated into a molded cover. APPLE-1023, FIG. 6, [0022], [0032], [0035]. In other words, a POSITA would have known that acrylic is a transparent material that can be readily transformed into various shapes, including a lens shape, as needed due to its easy molding properties. *Id.* Thus, a POSITA preferring improved light collection efficiency over reduced susceptibility to scratches could have been able to easily modify Aizawa's cover to have a lens shape as per Inokawa. *Id.* Indeed, only a routine knowledge of sensor design and assembly, which were well within the skill of a POSITA, would be required to perform such modifications. Thus, to achieve the goal of improving light collection efficiency, which both Aizawa and Inokawa share, a POSITA would have been able to, with a reasonable expectation of success, modify Aizawa's light permeable cover to have a lens shape as taught by Inokawa.

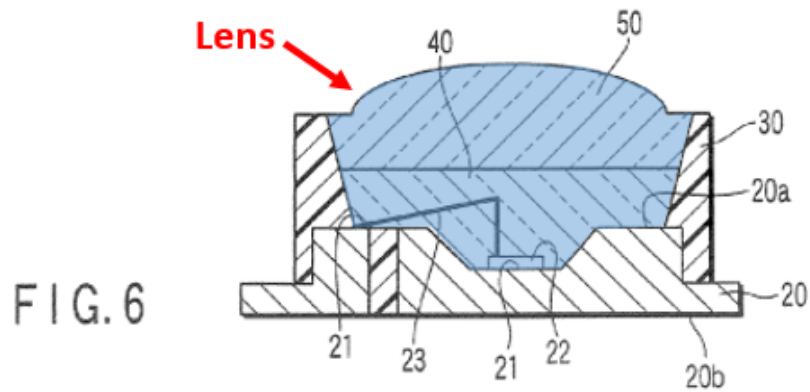

APPLE-1023, FIG. 6

**B. Claim 2**

**[2] The noninvasive optical physiological measurement device of claim 1, wherein the light permeable cover is attached to the housing and forms an airtight or substantially airtight seal enclosing the at least four detectors.**

100. As explained above with respect to element [1d] and shown below, the Aizawa-Inokawa combination would have included a light permeable cover that covers the detectors and is attached to the housing, thereby enclosing them.

APPLE-1006, [0023].

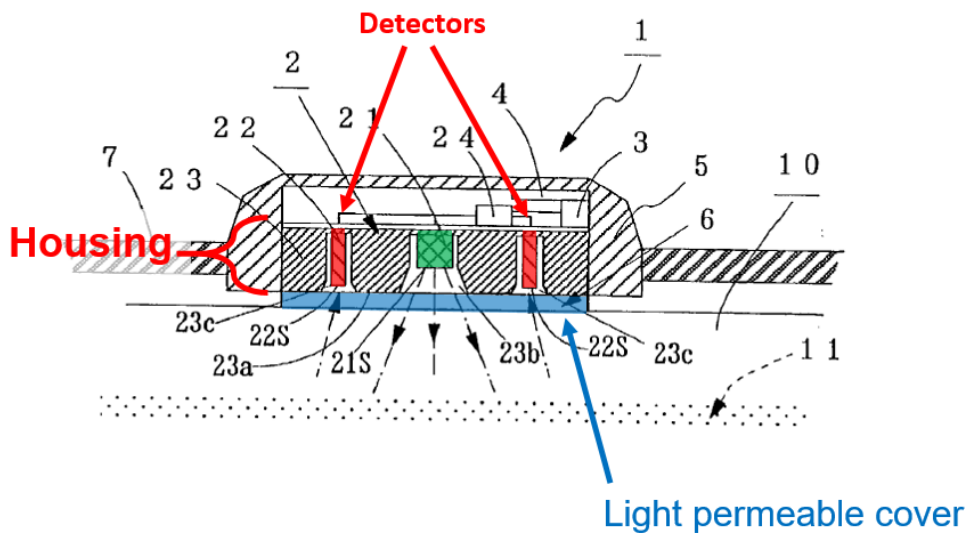

## APPLE-1006, FIG 1(b)

101. A POSITA would have also recognized that a wristwatch-like device, as in Aizawa and Inokawa, would be airtight or substantially airtight. For instance, it was well-known that wristwatch-type monitoring devices are hermetically sealed for improved convenience and functionality. *See* APPLE-1012, 5:11-20, 7:1-9; APPLE-1013, [0032]. This is especially true for body-worn devices because condensation, sweat, dust particles, environmental pollutants, and other undesirable elements may otherwise enter the housing and damage the sensitive internal electronics. *Id.* The fact that Aizawa’s sensor is designed for “measuring . . . heart rate at the time of exercise” makes it even more crucial that the device be airtight. APPLE-1006, [0004]. Thus, a POSITA would have recognized or found it obvious that the light permeable cover of Aizawa-Inokawa would form an airtight or substantially airtight seal to enclose the four detectors in a safe, well-protected environment that is safe from the elements.

### C. Claim 3

**[3] The noninvasive optical physiological measurement device of claim 2, wherein the circular wall creates a gap between the surface and the light permeable cover.**

102. As explained above with respect to [1b]-[1d] and shown below, the Aizawa-Inokawa combination would have included a light permeable cover that is separated from the surface of the housing by a gap. APPLE-1006, FIG. 1(b). The

size of this gap would be determined by the height of the circular wall of the housing that supports the cover.

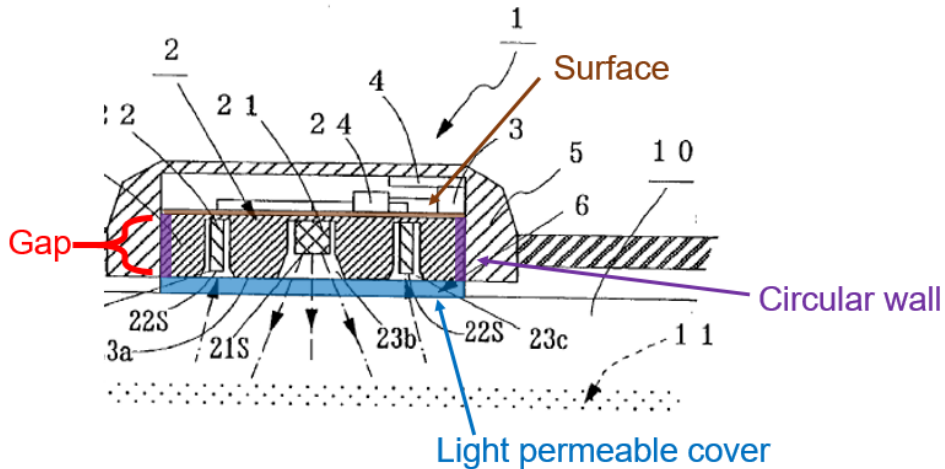

APPLE-10016, FIG. 1(b)

103. While a POSITA would have understood the term “gap” in this context to be referring to something akin to “a separation in space,” and thus clearly met by Aizawa’s disclosure above, I note that the Patent Owner may argue—falsely—that the gap requires an “air gap.” APPLE-1017, 515. Even then, Aizawa teaches cavities 23b/23c, which may be filled with air and thus comparable to an “air gap” whose size would be defined by the height of the circular wall. Indeed, a POSITA would have recognized the need to have such a “gap” around the LED and detectors to provide pathways for the light to enter the tissue, be reflected, and the get detected by the sensors.

**D. Claim 4**

**[4] The noninvasive optical physiological measurement device of claim 2, wherein the housing provides noise shielding for the at least four detectors.**

104. As explained above with respect to [1b], Aizawa teaches that the four detectors are surrounded by a holder 23, which a POSITA would have understood to be opaque and thus able to block unwanted ambient light from entering inside the housing. APPLE-1006, [0012], [0024], FIG. 1(b). In this way, this opaque material of the holder 23 would provide noise shielding to the detectors by blocking ambient light. While Aizawa doesn't expressly mention that the holder 23 is opaque, a POSITA certainly would have understood this to be the case. For example, Aizawa teaches that cavities formed within the holder 23 define the light receiving area. *Id.*, [0024], FIG. 1(b). Therefore, the non-cavity (*i.e.*, filled-in) portions would have to be opaque to be able to define the light receiving area. *Id.* Similarly, Aizawa teaches that the tapered cavity around the LED "makes it possible to expand the light emitting area"; thus, it is obvious that the material of the holder must be opaque—otherwise, there would be no benefit to introducing such a taper in the first place. *Id.*, [0012], [0024].

105. Moreover, as shown below, Inokawa teaches that a "visible light-blocking film" may be positioned in the housing to "block noise from visible light." APPLE-1008, [0105]-[0106].

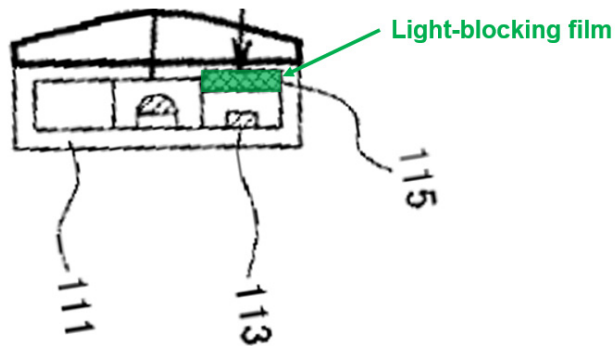

APPLE-1008, FIG. 16

106. In view of this teaching, a POSITA would have been found it obvious to add a similar light-blocking film to the housing of Aizawa, for instance underneath the light permeable cover and above the detectors, to minimize noise from undesired ambient light (*i.e.*, light that is not being used for signal detection) from reaching the detectors. The use of a light-blocking film as in Inokawa would ensure that the desired signals, for example IR wavelengths, can still pass through. *Id.*, [0105]-[0106]. A POSITA would have found it obvious to modify Aizawa based on Inokawa in this way because doing so simply requires using known solutions (using a light-blocking film to reduce noise by filtering out certain wavelengths of light) to improve similar systems in the same way. A POSITA would have recognized that adding Inokawa's light-blocking film to Aizawa's housing in the manner described above would have led to predictable result of reducing noise and improving signal collection without significantly altering or hindering the functions performed by Aizawa.

**E. Claim 6**

**[6] The noninvasive optical physiological measurement device of claim 3, wherein the protrusion comprises a continuous protrusion.**

107. As explained above with respect to [1d], the Aizawa-Inokawa combination would have included a light permeable cover with a lens-like protrusion. APPLE-1006, [0023], [0030]. FIG. 1(b); APPLE-1008, [0015], [0016], FIG. 2; APPLE-1009, 3:46-51, FIG. 1.

108. The lens/protrusion of Inokawa that would be incorporated into Aizawa has a continuous protrusion, as seen below.

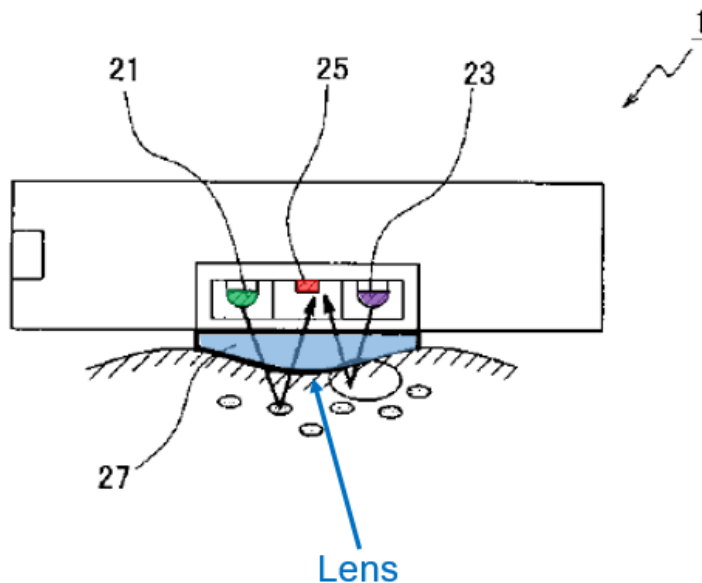

APPLE-1008, FIG. 2

**F. Claim 7**

**[7] The noninvasive optical physiological measurement device of claim 6, wherein the continuous protrusion comprises a convex protrusion.**

109. As explained above with respect to [1d], the Aizawa-Inokawa combination would have included a light permeable cover with a lens-like protrusion. APPLE-1006, [0023], [0030]. FIG. 1(b); APPLE-1008, [0015], [0016], FIG. 2; APPLE-1009, 3:46-51, FIG. 1.

110. The lens/protrusion of Inokawa that would be incorporated into Aizawa has a convex protrusion, as seen below. Indeed, Inokawa describes that its lens/protrusion is convex. APPLE 1008, [0099], [0107], FIGS. 2, 3, 16, 19.

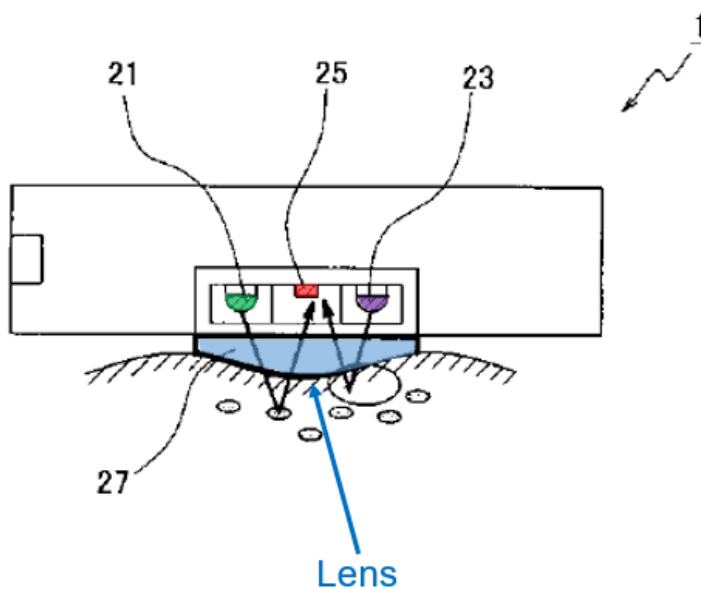

APPLE-1008, FIG. 2

### G. Claim 8

**[8] The noninvasive optical physiological measurement device of claim 6, wherein the light permeable cover is comprised of a rigid material.**

111. As discussed above for element [1d], the Aizawa-Inokawa combination would have included a light permeable cover that is made from transparent acrylic.



APPLE-1006, [0023], [0026], [0030], [0034]. A POSITA would have understood that such a material, especially when used to provide a structural component that is also serving an optical function, would be rigid, and indeed, acrylic is a well-known rigid material. *See* APPLE-1018 (“Acrylic is a transparent plastic material with outstanding strength, stiffness, and optical clarity.”)

112. A POSITA would have further found it obvious to use a rigid material to form the lens/protrusion in the Aizawa-Inokawa combination because, among other things, a rigid lens would be far better compared to a “pliable lens” (if such a thing even exists) in providing the improved optical performance and light-gathering function as contemplated in the combination. APPLE-1008, [0015], [0058]. This is because a non-rigid lens would deform, especially when pressed against the skin, and thereby result in degraded optical properties of the lens.

APPLE-1006, [0006], [0026].

#### **H. Claim 9**

**[9] The noninvasive optical physiological measurement device of claim 8, wherein the light permeable cover is configured to be positioned between the at least four detectors and tissue of a user when the noninvasive optical physiological measurement device is worn by the user.**

113. As explained above with respect to [1d], the Aizawa-Inokawa combination provides a light permeable cover with a lens-like protrusion. APPLE-1006, [0023], [0030]. FIG. 1(b); APPLE-1008, [0015], [0016], FIG. 2. As illustrated

below, the light permeable cover of Aizawa is, when worn, positioned between the detectors and the tissue of the user. APPLE-1006, FIG. 1(b).

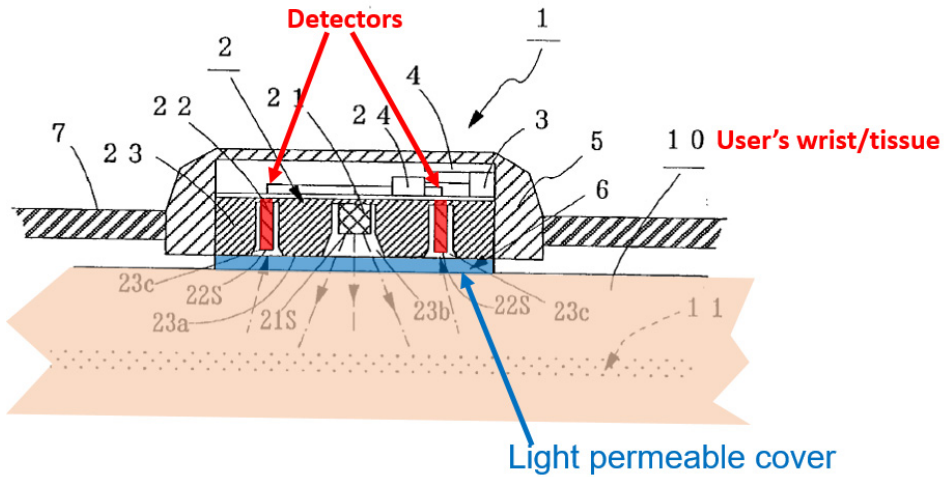

APPLE-1006, FIG. 1(b)

114. The light permeable cover of Aizawa, as modified in view of Inokawa as described above for the Aizawa-Inokawa combination, would be similarly positioned relative to the detectors and the tissue of the user when worn.

FIG. 1 (b)

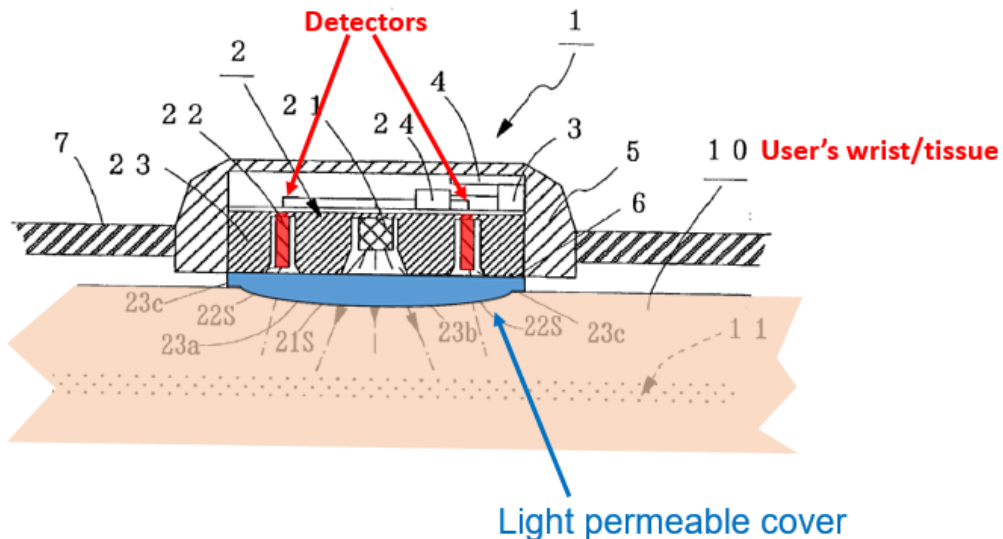

**I. Claim 10**

**[10] The noninvasive optical physiological measurement device of claim 9, wherein the light permeable cover is configured to press against and at least partially deform tissue of the user when the noninvasive optical physiological measurement device is worn by the user.**

115. As explained above with respect to [1d], the Aizawa-Inokawa combination provides a light permeable cover that is positioned on the skin of the user when worn. APPLE-1006, [0023], [0030]. FIG. 1(b); APPLE-1008, [0015], [0016], FIG.

2. Moreover, the light permeable cover of Aizawa is designed to be pressed toward the skin of the user with some pressure. APPLE-1006, [0006], [0026]. Being pressed into the skin in this manner will cause at least the tissue at least partially deform because the skin is less rigid than the light permeable cover, for example as demonstrated below by Inokawa where it can be seen that the user's tissue has deformed around the protruded surface of the cover.

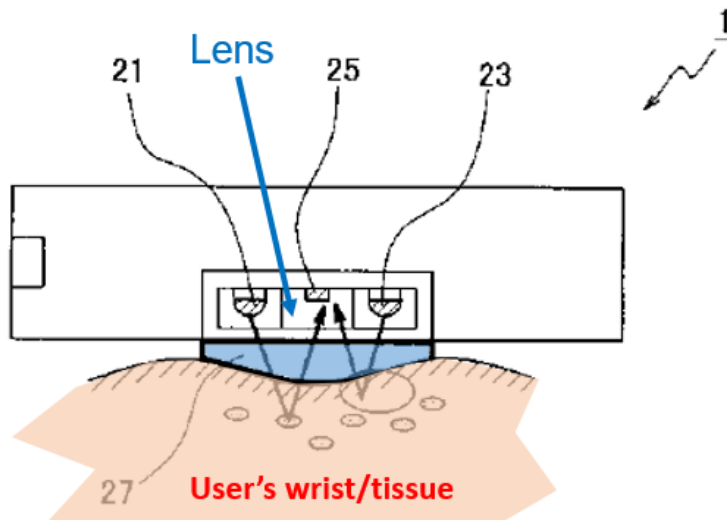

APPLE-1008, FIG. 2

116. Similarly, when the lens of Inokawa is incorporated into Aizawa as discussed above for element [1d], the protrusion will cause the tissue of the user, which is less rigid than the protrusion, to deform around the convex surface of the lens/protrusion when the device is pressed against the tissue during use.

FIG. 1 (b)

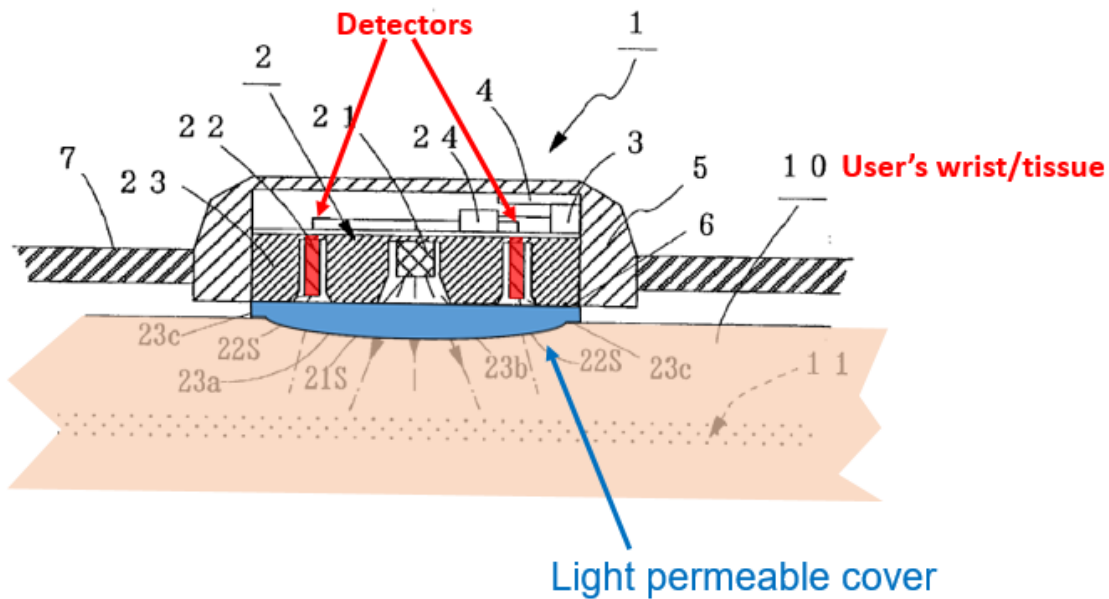

APPLE-1006, FIG. 1(b)

**J. Claim 11**

**[11] The noninvasive optical physiological measurement device of claim 10, wherein the light permeable cover is configured to act as a tissue shaper and conform tissue of the user to at least a portion of an external surface shape of the light permeable cover when the noninvasive optical physiological measurement device is worn by the user.**

117. As explained above with respect to [10], the light permeable cover in the Aizawa-Inokawa combination deforms the tissue of the user around the

lens/protrusion during use. APPLE-1006, [0006], [0026]; APPLE-1008, FIG. 2.

In this way, the lens/protrusion acts as a tissue shaper that helps conform the tissue of the user to an external surface of the lens/protrusion when the device is worn by the user. *Id.* As explained for [10], this happens because a protruded surface that is more rigid than the skin is being pressed into the skin and, accordingly, the less rigid skin will at least partially deform to conform to the rigid protrusion. *Id.*

#### **K. Claim 12**

**[12] The noninvasive optical physiological measurement device of claim 11, wherein the light permeable cover is configured to reduce a mean path length of light traveling to the at least four detectors.**

118. Regarding the reduction of mean path length, the '265 patent mentions, in the context of a transmittance-type device, that using a protruded cover to deform the skin can cause “the mean optical path length from the emitters to the detectors can be reduced and the accuracy of blood analyte measurement can increase.”

APPLE-1001, 20:25-20, FIG. 5. Although the '265 patent is silent regarding how such path reduction would apply in a reflectance-type sensor, a POSITA still would have recognized that an analogous effect can be achieved the Aizawa-Inokawa combination.

119. In more detail, I noted above for [1d] how the lens/protrusion of Inokawa, which is used to modify Aizawa's cover, provides a condensing function by refracting the light passing through it. APPLE-1008, [0015], [0058]. As

demonstrated through my drawings below, where the left figure shows the length of non-refracted light and the right figure shows the length of refracted light, such refraction of the incoming reflected light can shorten the path of the light before it reaches the detector. This is because the incoming light is “condensed” toward the center. APPLE-1008, [0015], [0058]. Thus, as demonstrated by the drawings below, both the total length of travel as well as the length through the tissue can be reduced.

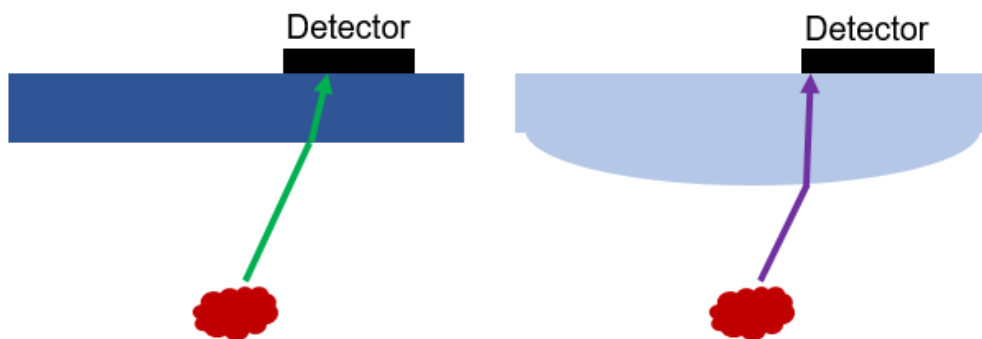

120. Laying these two drawings on top of each other, as shown below, the shortened path length within the tissue for the purple (refracted) line can be clearly seen compared to the path length within the tissue of the green (non-refracted) line. The shortened *total* path length of the purple line compared to the green line can also be seen. Accordingly, the Aizawa-Inokawa combination, through its use of a condensing lens between the tissue and the detectors, serves to reduce a mean path length of light traveling to the at least four detectors

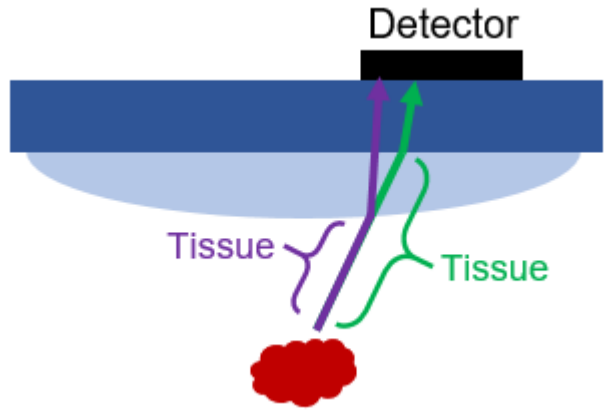

**L. Claim 13**

**[13] The noninvasive optical physiological measurement device of claim 11, wherein the at least four detectors are evenly spaced from one another.**

121. As explained above with respect to [c], Aizawa teaches at least for detectors.

APPLE-1006, [0029], [0024], [0032], FIG. 1(a). Further, as shown below, the four detectors are evenly spaced from one another. *Id.*

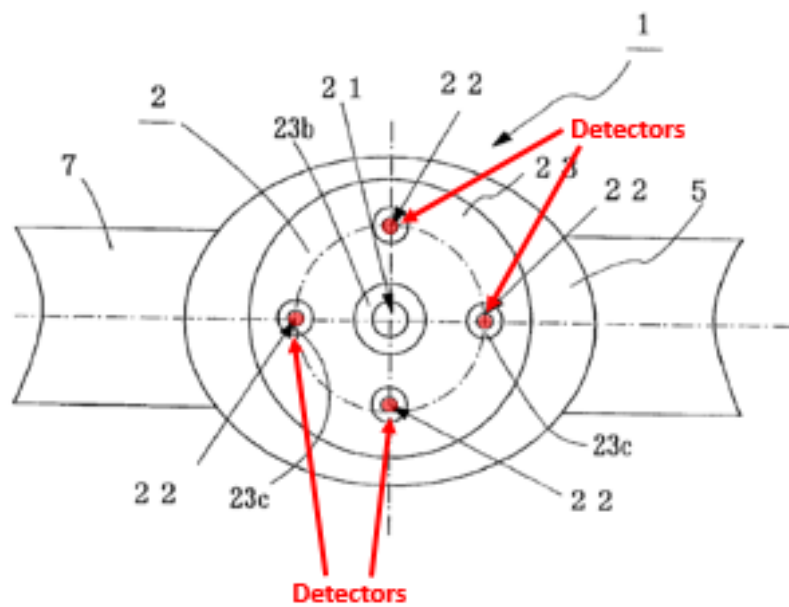

APPLE-1006, FIG. 1(a)

**M. Claim 14**

**[14] The noninvasive optical physiological measurement device of claim 1, wherein the light permeable cover is configured to reduce a mean path length of light traveling to the at least four detectors.**

122. As I explained above for [12], the analysis for which I fully incorporate herein, the Aizawa-Inokawa combination includes a light permeable cover (i.e., lens) that is configured to reduce a mean path length of light traveling to the at least four detectors. APPLE-1008, [0015], [0058].

#### **N. Claim 16**

**[16] The noninvasive optical physiological measurement device of claim 13, wherein the light permeable cover is configured to increase a signal strength per area of the at least four detectors.**

123. As I explained above with respect to [1d], the Aizawa-Inokawa combination includes provides a light permeable cover with a convex protrusion that acts as a lens, thereby enhancing the device's light-gathering ability. APPLE-1008, [0015], FIG. 2. Indeed, a POSITA would have known that a lens, as in Inokawa and as incorporated into Aizawa, would condense incoming light onto the detectors, thus increasing the signal to noise ratio as well as the signal strength per area of the detectors (since each detector area will receive more incoming light signals).

#### **O. Claim 17**

**[17] The noninvasive optical physiological measurement device of claim 1, wherein the physiological parameter is pulse rate.**

124. As explained above with respect to [1pre], the sensor of Aizawa is designed to measure physiological parameters including the user's pulse rate. APPLE-1006,



[Abstract], [0002], [0008], [0023]-[0036]. Inokawa also teaches a sensor that measures pulse rate. APPLE-1008, Abstract, [0001], [0007], [0056]-[0072].

**P. Claim 19**

**[19] The noninvasive optical physiological measurement device of claim 1, wherein the noninvasive optical physiological measurement device is a disposable or a reusable device.**

125. As an initial matter, most, if not all, sensing devices will be either disposable or reusable. If the device is meant to be discarded after a single use, then a POSITA would understand it to be disposable. If the device is designed to be used multiple times, then a POSITA would understand it to be reusable. In particular regarding Aizawa's wrist-worn device, a POSITA would have recognized that it would be reusable because, among other things, it will likely be very expensive to use such a device one time and discard after each use. Indeed, Aizawa teaches attaching the sensor to the user's wrist using an attachment belt 7 and "carry[ing] [the pulse rate detector] for a long time." APPLE-1006., [0023], [0026], [0031]. A POSITA would have recognized that such a device for long-term use is typically a reusable device. To the extent Patent Owner argues that Aizawa is designed to be thrown away after being used, then Aizawa's device would be disposable, thereby still satisfying this limitation.

**Q. Claim 20**

**[20] The noninvasive optical physiological measurement device of claim 1, wherein a first detector is arranged spaced apart from a second detector, and a third detector arranged spaced apart from a fourth detector.**

126. As explained above with respect to [1c] and [13], incorporated herein, the Aizawa-Inokawa combination includes four detectors. APPLE-1006, [0029], [0024], [0032], FIG. 1(a). Moreover, as illustrated below, the four detectors of Aizawa are spaced from one another such that a first detector is spaced apart from a second detector, and a third detector is spaced apart from a fourth detector. I've identified the detectors of Aizawa as 1<sup>st</sup>, 2<sup>nd</sup>, 3<sup>rd</sup>, and 4<sup>th</sup>, but this particular identification is arbitrary and other numbering schemes may be used.

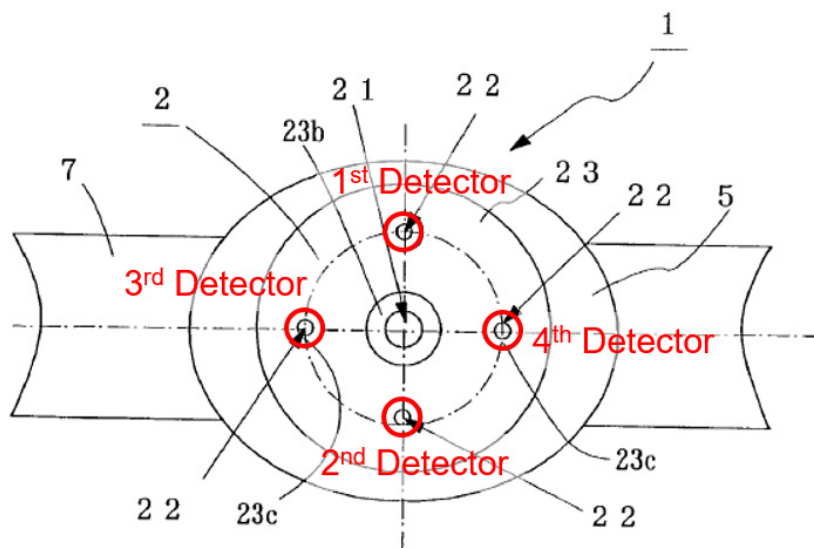

APPLE-1006, FIG. 1(a)

**R. Claim 21**

**[21] The noninvasive optical physiological measurement device of claim 20, wherein the first detector is arranged across a central axis from the second detector and the third detector is arranged across the central axis from the**

**fourth detector, wherein the first, second, third and fourth detectors form a cross pattern about the central axis.**

127. The Aizawa-Inokawa combination discloses this element. For example, referring to the numbering scheme I used in my analysis of claim 20, and as shown below, the four detectors of Aizawa are arranged such that the first detector is arranged across a central axis (shown in brown) from the second detector and the third detector is arranged across the central axis from the fourth detector. APPLE-1006, [0029], [0024], [0032], FIG. 1(a). Moreover, as I show below in blue, the first, second, third and fourth detectors form a cross pattern about the central axis.

*Id.*

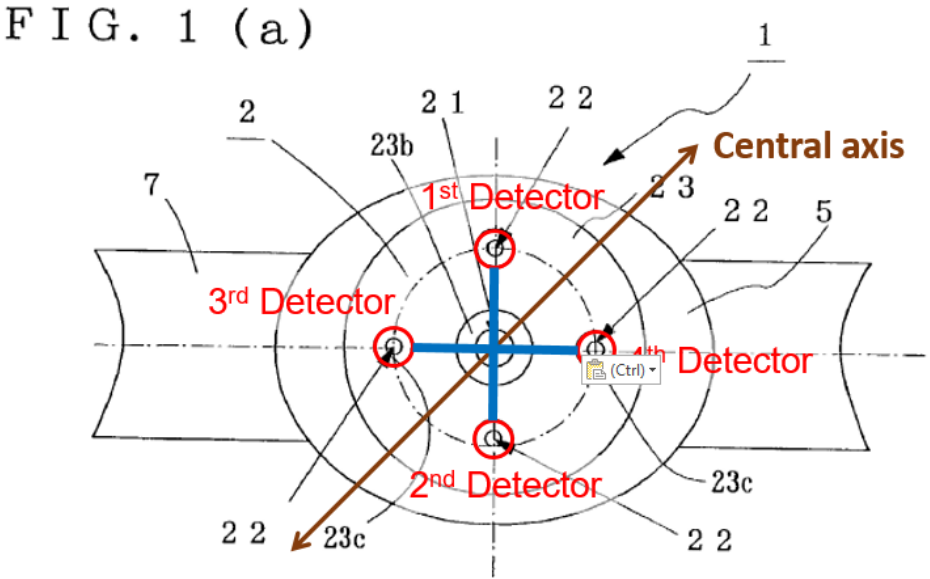

APPLE-1006, FIG. 1(a)

**S. Claim 22**

**[22] The noninvasive optical physiological measurement device of claim 20, wherein the noninvasive optical physiological measurement device provides a variation in optical path length to the at least four detectors.**

128. As explained above with respect to [12], incorporated herein, the Aizawa-Inokawa combination provides a lens/protrusion that refracts incoming light and thereby changes the optical path length to the detectors. APPLE-1008, [0015], [0058]. Moreover, since the process for getting light into and out of the tissue depends on scattering, light entering and returning from the tissue will follow many different random paths, with many different lengths. Additionally, since the emitter is not a point source, and the detector has a finite area of detection, there are multiple paths from a portion of the emitter to a portion of the detector. As an example, in the drawings shown in Aizawa, the emitter is represented as having rays emerging from locations across its surface. APPLE-1006, FIG. 1(b). These rays propagate into the tissue and some find their way back to some portion of the surface of the detectors. Thus, aside from the variations in the path associated with the randomness of the scattering, there is also a variation associated with the finite area of these elements. Accordingly, there will be a variation in optical path length to the four detectors.

#### **T. Claim 23**

**[23] The noninvasive optical physiological measurement device of claim 1, wherein the noninvasive optical physiological measurement device is comprised as part of a mobile monitoring device.**

129. As explained above with respect to [1pre]-[1d], the Aizawa-Inokawa combination provides a noninvasive optical physiological measurement device. APPLE-1006, [0002], [0026], FIG. 2. Moreover, Aizawa teaches that its sensor—namely “pulse rate detector 1”—can be “attached to the wrist 10 with the belt 7 ... thereby making it possible to carry it for a long time.” APPLE-1006, [0026], [0023], [0031]. In other words, the belt 7 allows Aizawa’s detector to be carried around as a mobile monitoring device. APPLE-1006, [0026]. Thus, the detector 1 and belt 7 of Aizawa can together be viewed as providing the claimed mobile monitoring device. An alternative mapping is provided below in Ground 1C.

#### U. Claim 26

**[26pre] A noninvasive optical physiological measurement device adapted to be worn by a wearer providing an indication of a physiological parameter of the wearer comprising:**

130. For reasons I discussed above in ¶ 73 with respect to element [1pre], herein incorporated by reference, this limitation is rendered obvious by the Aizawa-Inokawa combination. APPLE-1006, [0002], [0026], FIG. 2.

**[26a] a plurality of emitters of different wavelengths;**

131. For reasons I discussed above in ¶¶ 74-86 with respect to element [1a], herein incorporated by reference, this limitation is rendered obvious by the Aizawa-Inokawa combination. APPLE-1006, [0023], [0033]; APPLE-1008, [0014], [0044], [0058], [0059], FIG. 2.

**[26b] a circular housing comprising a surface with a raised edge;**

132. For reasons I discussed above in ¶¶ 87-88 with respect to element [1b], herein incorporated by reference, the Aizawa-Inokawa combination discloses a housing with a surface. APPLE-1006, [0023], [0024], FIG. 1(b). Additionally, as illustrated below, the housing of Aizawa (colored red) is circular and includes a surface (colored purple) having a raised edge (colored purple). *Id.*

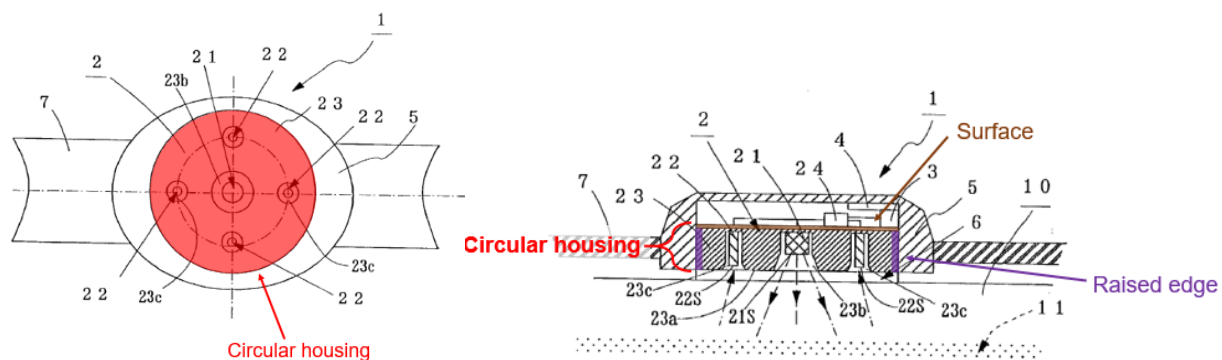

APPLE-1006, FIGS. 1(a), 1(b)

**[26c] at least four detectors arranged on the surface, wherein a first detector is arranged spaced apart from a second detector, and a third detector arranged spaced apart from a fourth detector; and**

133. For reasons I discussed above in ¶¶ 89-91, 121 with respect to elements [1c] and [13], herein incorporated by reference, this limitation is rendered obvious by the Aizawa-Inokawa combination. APPLE-1006, [0023], [0033]; APPLE-1008, [0014], [0044], [0058], [0059], FIG. 2. APPLE-1006, [0029], [0024], [0032], FIG. 1(a).

**[26d] a cover of the circular housing comprising a lens portion, the lens portion comprising a protrusion in optical communication with the at least four detectors,**

134. For reasons I discussed above in ¶¶ 92-99 with respect to element [1d], herein incorporated by reference, this limitation is rendered obvious by the Aizawa-Inokawa combination. APPLE-1006, [0023], [0030], FIG. 1(b); APPLE-1008, [0015], FIG. 2. In more detail, because reflected light that is received by Aizawa's four detectors must first pass through the lens portion, as provided by Inokawa, the lens portion is in optical communication with the at least for detectors. APPLE-1006, FIG. 1(b), [0023];

**[26e] wherein the at least four detectors are configured to output one or more signals responsive to light from the one or more light emitters attenuated by body tissue, the one or more signals indicative of a physiological parameter of the wearer.**

135. For reasons I discussed above in ¶¶ 89-91 with respect to element [1c], herein incorporated by reference, this limitation is rendered obvious by the Aizawa-Inokawa combination. APPLE-1006, [0023], [0024], [0027]-[0029], [0032], FIGS. 1(a)-1(b).

## V. Claim 27

**[27] The noninvasive optical physiological measurement device of claim 26, wherein the first detector is arranged across a central axis from the second detector and the third detector is arranged across the central axis from the fourth detector, wherein the first, second, third and fourth detectors form a cross pattern about the central axis..**

136. For reasons I discussed above in ¶ 127 with respect to element [21], herein incorporated by reference, this limitation is rendered obvious by the Aizawa-Inokawa combination. APPLE-1006, [0029], [0024], [0032], FIG. 1(a).

## W. Claim 28

**[28] The noninvasive optical physiological measurement device of claim 26, wherein the at least four detectors are arranged in a grid pattern such that the first detector and the second detector are arranged across from each other on opposite sides of a central point along a first axis, and the third detector and the fourth detector are arranged across from each other on opposite sides of the central point along a second axis which is perpendicular to the first axis.**

137. For reasons I discussed above in ¶ 127 with respect to element [21], herein incorporated by reference, and as shown below, this limitation is rendered obvious by the Aizawa-Inokawa combination. APPLE-1006, [0029], [0024], [0032], FIG. 1(a). In more detail, as illustrated below, the detectors are arranged in a grid pattern relative to a central point, and the first/second axes, for example as identified below, are perpendicular to each other. Moreover, because of the high symmetry (rotations and reflections) of the arrangement of four detectors with respect to the central point, there are many grids that can be drawn which would meet the limitations of this claim element. The illustration provided is just one of many possible grids. This symmetry provides many obvious and useful benefits, including reduced sensitivity to the location of the device relative to the anatomy, manufacturing convenience, assembly convenience, and likely customer appreciation of the aesthetics associated with symmetry that come with the overall circular shape and preferred styles for wrist-worn objects.



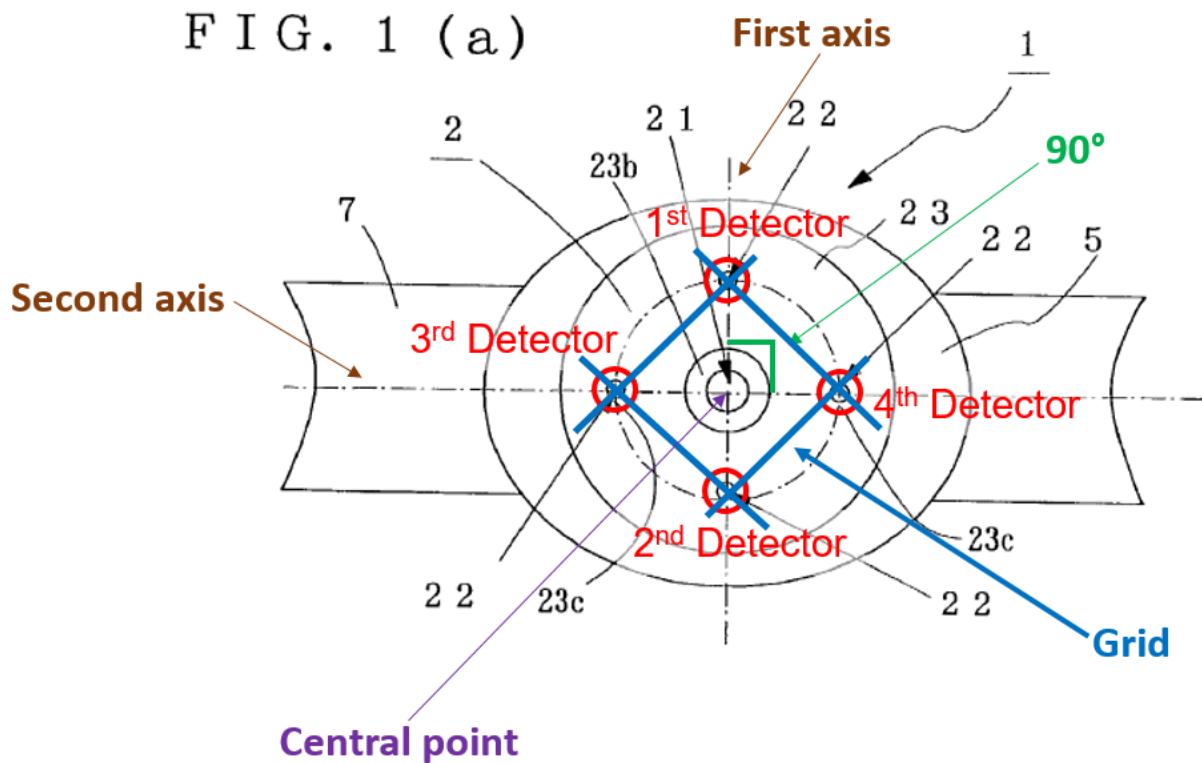

APPLE-1006, FIG. 1(a)

**X. Claim 29**

[29] The noninvasive optical physiological measurement device of claim 27, wherein the first, second, third and fourth detectors form a cross pattern about the central axis.

138. For reasons I discussed above in ¶ 127 with respect to element [21], herein incorporated by reference, this limitation is rendered obvious by the Aizawa-Inokawa combination. APPLE-1006, [0029], [0024], [0032], FIG. 1(a).

**IX. GROUND 1B –Claims 1-4, 6-14, 16, 17, 19-23, and 26-29 Are Rendered Obvious by Aizawa in view of Inokawa and Ohsaki**

**A. Claims 1-4, 6-14, 16, 17, 19-23, and 26-29**

**[1d] a light permeable cover arranged above at least a portion of the housing, the light permeable cover comprising a protrusion arranged to cover the at least four detectors.**

139. As I explained above in ¶¶ 92-99 with respect to element [1d], a POSITA would have been motivated to incorporate a lens-like protrusion of Inokawa into the cover of Aizawa to increase the light collection efficiency.

140. Ohsaki (APPLE-1014), which I briefly described above ¶¶ 64-65, provides an alternative/additional rationale for why a POSITA would have modified the flat shape of Aizawa's acrylic plate into a "light permeable cover comprising a protrusion" as per element [1d].

141. Among other things, Ohsaki teaches that adding a convex surface to its translucent board 8 (*i.e.*, light permeable cover) can help prevent the device from slipping on the tissue of the wearer compared to using a flat cover without such a protrusion. APPLE-1014, [0025].

FIG. 2

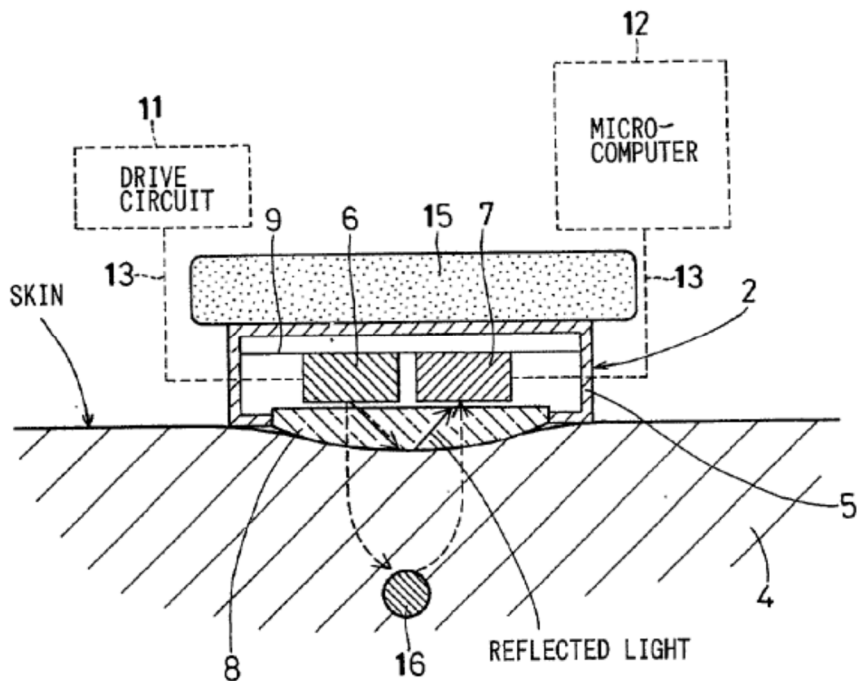

APPLE-1014, FIG. 2

142. Minimizing slippage between a user-worn sensor device and the tissue of the user was indeed a well-known objective in such devices. For example, Aizawa teaches using its acrylic transparent plate 6 (*i.e.*, light permeable cover) to improve “adhesion between the wrist 10 and the pulse rate detector 11.” APPLE-1006, [0026], [0030]. While Aizawa doesn’t discuss whether the shape of its acrylic plate could be modified to achieve this objective, a POSITA in possession of both Aizawa and Ohsaki would have recognized that Ohsaki’s addition of a convex protrusion to its light permeable cover could be similarly implemented in Aizawa’s device to help achieve the two references’ shared goal of minimizing slippage. *Id.* In other words, a POSITA seeking to achieve improved adhesion between the

detector and the skin, as expressly recognized in Aizawa, would have been motivated and readily able to modify Aizawa's acrylic plate to have a convex shape as in Ohsaki. This would have allowed Aizawa's sensor device to remain better adhered to the skin and thereby increase its light-collecting efficiency. APPLE-1006, [0026], [0030]; APPLE-1014, [0025]. Additionally, a POSITA would have appreciated that the lens/protrusion in the Aizawa-Inokawa combination as detailed above in ¶¶ 92-99 would have provided a similar anti-slippage advantage due to the lens's convex shape, thereby providing an additional motivation for a POSITA to make the above-noted modification of Aizawa in view of Inokawa's lens.

143. The resulting Aizawa-Inokawa-Ohsaki combination satisfies all remaining elements of claims 1-4, 6-17, 19-23, and 26-29 in the same manner as previously described in Ground 1A, which is herein incorporated by reference.

**X. GROUND 1C – Claims 23-24 Are Rendered Obvious by Aizawa in view of Inokawa and Mendelson-2006**

**A. Claim 23**

**[23] The noninvasive optical physiological measurement device of claim 1, wherein the noninvasive optical physiological measurement device is comprised as part of a mobile monitoring device.**

144. As an initial matter, I note that Aizawa teaches uploading data to an external display/device but is silent about how such data transmission would actually be

implemented, instead leaving implementation details to the POSITA. APPLE-1006, [0015], [0023], [0035]. In other words, Aizawa does not disclose a specific monitoring device, mobile or otherwise, that can display the measured physiological data to the user, but a POSITA would have nonetheless recognized that different types of monitoring devices, including those that are mobile, could be used to interact with the wrist-worn sensor of Aizawa and display the measured physiological parameters to the user in a convenient manner.

145. Mendelson-2006 (APPLE-1016), which I briefly described above in ¶¶ 69-71, provides a sensor module, similar to what is provided by Aizawa, that can be attached to a user and a body-worn receiver module and that can wirelessly receive information acquired by the sensor module. APPLE-1016, 913, FIG. 1.

Physiological data received and processed by the receiver module can then be wirelessly transmitted to a “PC” or PDA for convenient monitoring of physiological parameters, for instance remotely by medics. *Id.*, 913-914. In some cases, for instance when there are wireless connectivity issues between the receiver module and the PC/PDA, a physical wire may be used to connect Mendelson-2006’s PDA to the receiver module. Indeed, Mendelson-1996’s receiver module includes a UART that provides a serial port for data transmission, as seen below. APPLE-1016, 913, FIG. 1; APPLE-1029. A POSITA would have recognized that a wire, such as a “Sync Cable,” can be used to physically connect Mendelson-

1996's PDA to such a port in instances where, for example, a more secure and/or reliable connection is desired. APPLE-1022, 8.

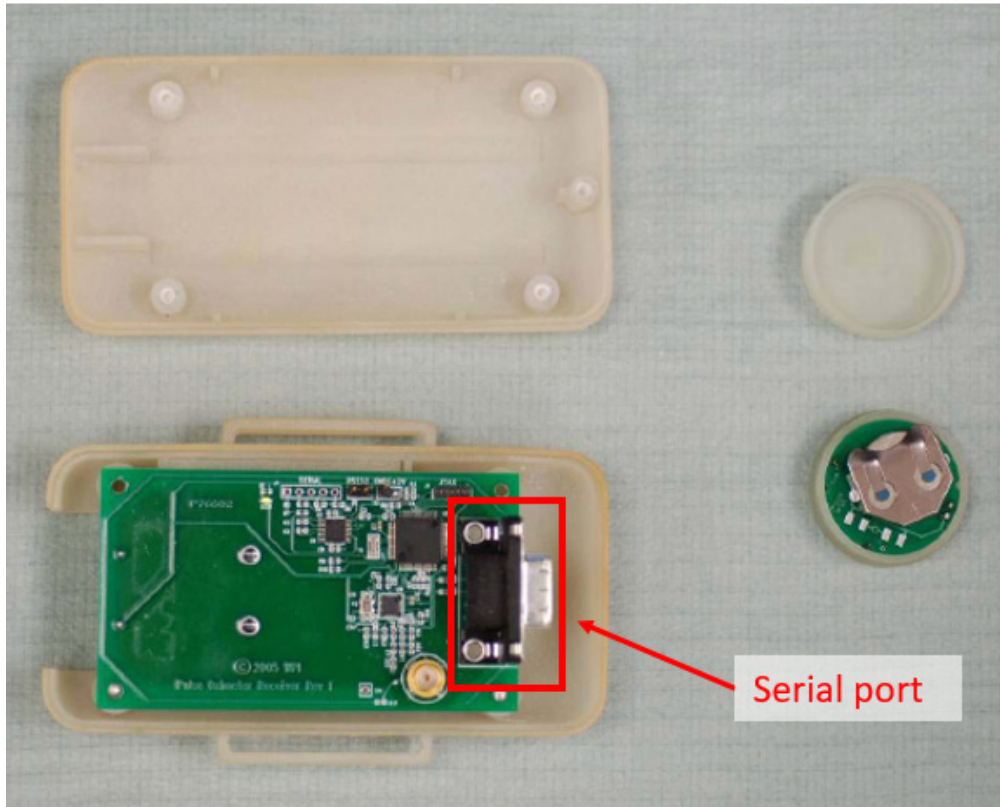

APPLE-1016 FIG. 1

146. A POSITA in possession of both Aizawa and Mendelson-2006 would have found it obvious to further modify the Aizawa-Inokawa<sup>1</sup> combination in view of

---

<sup>1</sup> Alternatively, the combination of Aizawa, Inokawa, *and Ohsaki*, with Ohsaki being used to provide an additional/alternative motivation to transform the flat plate of Aizawa to have a protrusion as I described above in ¶¶ 139-142, may be similarly modified in view of Mendelson-2006 to yield a similar result.

Mendelson-2006 to create a pulse detector that can wirelessly transmit data to an external device for monitoring. For instance, Aizawa, Inokawa, and Mendelson-2006 are all in the same field of pulse sensing, wrist-worn device and would have motivated a POSITA to collectively consider their various features and benefits. APPLE-1006, [0002]; APPLE-1008, [0056]; APPLE-1016, 912. In this context, Mendelson-2006 teaches the use of a receiver module and a portable computer or PDA to receive pulse data from a body-worn detector. APPLE-1016, 913-914.

147. A POSITA would have thus found it obvious to combine Mendelson-2006's receiver module and PC/PDA with Aizawa's detector to thereby provide a convenient and user-friendly interface to Aizawa's detector, which does not include a separate display/interface, and enable, for instance, remote monitoring of the user's physiological parameters. APPLE-1016, 914. A POSITA would have recognized that incorporating Mendelson-2006's receiver module and PC/PDA to Aizawa's sensor would have led to a predictable result without significantly altering or hindering the functions already performed by Aizawa's sensor. Indeed, a POSITA would have had a reasonable expectation of success in making this modification, and would have reasonably expected to reap Mendelson-2006's benefits of convenient interface and remote monitoring using Aizawa's sensor.

148. In the alternative, I note that in the Aizawa-Inokawa combination as detailed above in ¶¶ 80-85, the base device 17 of Inokawa can be used to receive pulse data

from Aizawa's sensor. APPLE-1008, [0007], [0077]. Moreover, as I noted above in ¶ 63, the base device of Inokawa is further configured to transmit the received data to a PC. APPLE-1008, FIG. 7, [0066]-[0077].

149. Here, it's not clear whether Inokawa contemplates the use of a mobile or otherwise portable PC that would allow the base device to be readily carried around. Nevertheless, Inokawa does not place any restrictions on which type of PC may be used. *Id.* Thus, a POSITA would have recognized that a mobile PC such as the Pocket PC/PDA used in Mendelson-2006 would have allowed the sensor and the base device of Aizawa-Inokawa to be used in a more convenient, portable manner. APPLE-1016, FIG. 3, 913-914. Thus, the Aizawa-Inokawa device, further combined with the mobile PC of Mendelson-2006 that is connected to Inokawa's base device as its PC, additionally provides the claimed mobile monitoring device. As noted above, the mobile PC of Mendelson-2006 may be connected either wirelessly or with a wire. APPLE-1016, 913, FIG. 1; APPLE-1029; APPLE-1022, 8.

#### **B. Claim 24**

**[24] The noninvasive optical physiological measurement device of claim 1, wherein the mobile monitoring device includes a touch-screen display.**

150. Referring back to my discussion of element [23] in ¶ 129, which is incorporated herein, I explained how a POSITA would have looked to Mendelson-2006's PDA to enable more convenient, mobile monitoring of the user's



physiological parameters. APPLE-1016, 913-914. Here, Mendelson-2006's PDA, reproduced below, provides "a low-cost touch screen interface," thus satisfying the touch-screen display limitation. APPLE-1016, 914.



APPLE-1016, FIG. 3.

**XI. GROUND 1D – Claims 23-24 Are Rendered Obvious by Aizawa in view of Inokawa, Goldsmith, and Lo**

**A. Claim 23**

**[23] The noninvasive optical physiological measurement device of claim 1, wherein the noninvasive optical physiological measurement device is comprised as part of a mobile monitoring device.**

151. As an initial matter, I note that Goldsmith teaches a "combined watch and controller device 900" that "includes a housing 905 adapted to be worn or carried by the user" as well as "a display 910." APPLE-1027, [0085]. The wristwatch

controller of Goldsmith can receive “information about a patient” and “may monitor heart rate or and/or metabolic rate.” *Id.*, [0095]. In some cases, “data may [be] received directly from a sensor transmitter on the patient's skin.” *Id.*, [0087]. Also, in some cases, “the display is a touchscreen display.” *Id.*, [0086]. The wristwatch controller of Goldsmith is shown below, with the touchscreen display indicated in red.

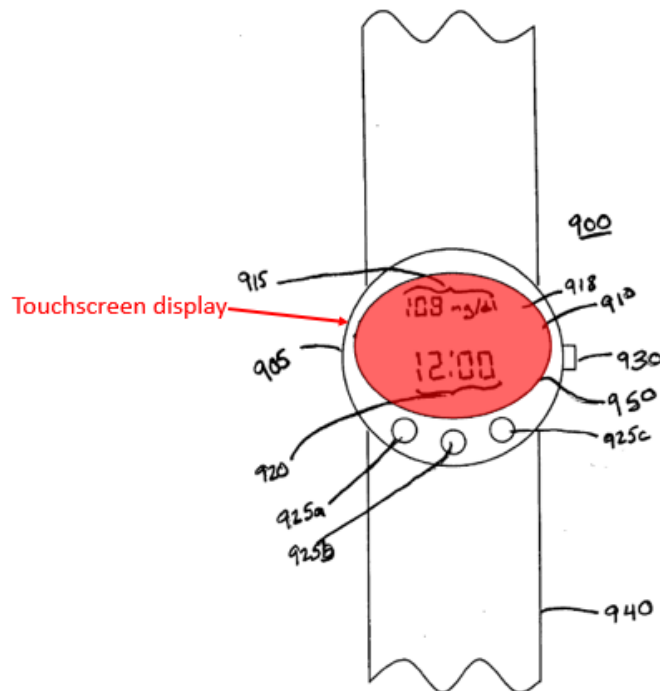

APPLE-1027, FIG. 9A.

152. As seen below, Lo is another wristwatch-type pulse rate monitor that has a display unit 40 (colored red), a transducer/sensor module 20 (colored blue), and a wristband 10 (colored green). APPLE-1028, [0002], [0019]. Lo teaches that it is preferable to have both the display unit and the sensor unit attached to the same

strap. *Id.*, [0035]. Although the particular sensor unit described in Lo is a ultrasonic transducer that works by using sonic energy to measure the user's pulse rate, other types of sensors, such as optical sensors, may also be used. *Id.*, [0025], [0026], [0048].

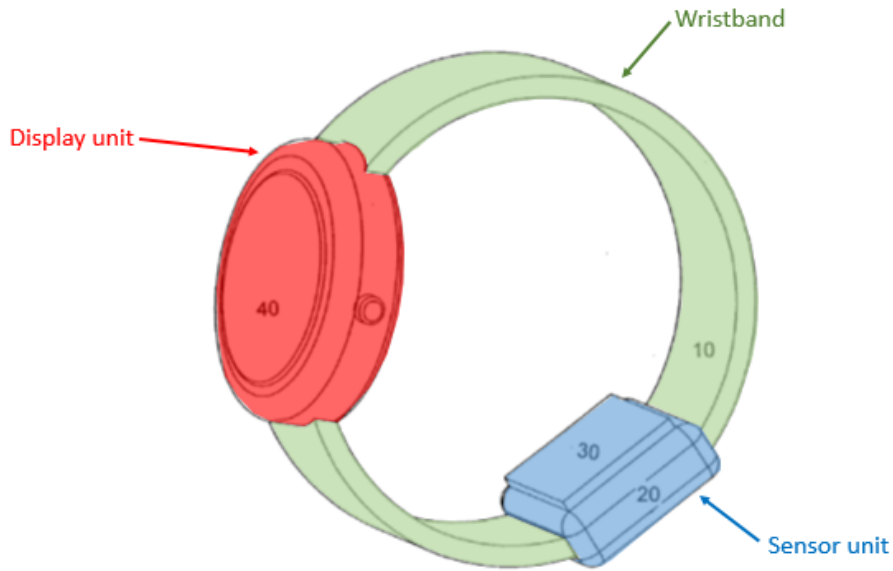

APPLE-1028, FIG. 1

153. A POSITA in possession of Aizawa, Goldsmith, and Lo would have found it obvious to further modify the Aizawa-Inokawa<sup>2</sup> combination in view of Goldsmith and Lo to create an integrated pulse monitoring device that is the form of a

---

<sup>2</sup> Alternatively, the combination of Aizawa, Inokawa, *and Ohsaki*, with Ohsaki being used to provide an additional/alternative motivation to transform the flat plate of Aizawa to have a protrusion as I described above in ¶¶ 139-142, may be similarly modified in view of Goldsmith and Lo to yield a similar result.

wristwatch. For instance, Aizawa, Inokawa, and Goldsmith, and Lo are all in the same field of wrist-based pulse sensing, and thus would have motivated a POSITA to collectively consider their various features and benefits.

154. In more detail, Goldsmith provides a wristwatch-type monitoring device that can “monitor heart rate or and/or metabolic rate” by receiving data “directly from a sensor transmitter on the patient’s skin.” APPLE-1027, [0095], [0087]. A POSITA would have found it obvious to further modify the Aizawa-Inokawa combination in view of Goldsmith to allow a user to more conveniently monitor his/her heart rate, for example during times of exercise, as mentioned in Aizawa. APPLE-1006, [0004]. Goldsmith discloses receiving data from a separate sensor, and Aizawa provides just such a sensor. APPLE-1027, [0087].

155. Here, I note that a POSITA would have recognized that Goldsmith’s display and Aizawa’s sensor could be two separate devices or integrated into a single device. In fact, Lo expressly teaches that a sensor “can be fastened separately on its own strap” (APPLE-1028, [0037]), or—alternatively and more preferably—the sensor and the display can be integrated together into a more convenient wristwatch form by using “[c]onnecting wires [that] are molded into the wrist band.” APPLE-1028, [0038]; FIG. 1.

156. Therefore, a POSITA would have been motivated to apply Lo’s integrated monitor-sensor configuration to the combined Aizawa-Inokawa-Goldsmith device

(*i.e.*, mobile monitoring device) to provide an integrated, mobile, and wrist-worn pulse sensing device that can be conveniently used during various activities, such as swimming and diving, to actively monitor the user's physiological parameter (*i.e.*, heart rate). APPLE-1028, [0038].

**B. Claim 24**

**[24] The noninvasive optical physiological measurement device of claim 1, wherein the mobile monitoring device includes a touch-screen display.**

157. As I explained above for claim 23, in the Aizawa-Inokawa-Goldsmith-Lo combination, Goldsmith provides a wristwatch monitor with a touchscreen display. APPLE-1027, [0086].

**XII. GROUND 1E – Claim 25 Is Rendered Obvious by Aizawa in view of Inokawa, Mendelson-2006, and Beyer, Jr.**

**A. Claim 25**

**[25pre] A physiological monitoring system comprising**

158. The Aizawa-Inokawa-Mendelson-2006 combination as described above in ¶¶ 144-149 results in a physiological monitoring system. In more detail, , the Aizawa-Inokawa-Mendelson-2006 combination provides a monitoring system that includes the sensor of Aizawa and the mobile PC of Mendelson-02006. APPLE-1006, [0002], [0026], FIG. 2; APPLE-1016, 913-914, FIG. 3.

**[25a] the noninvasive optical physiological measurement device of claim 1; and**

159. For reasons I discussed above in ¶¶ 73-99 with respect to elements [1pre]-[1d], herein incorporated by reference, this limitation is rendered obvious by the Aizawa-Inokawa combination.

**[25b] a processor configured to receive the one or more signals and communicate physiological measurement information to a mobile phone.**

160. As I discussed in ¶¶ 144-149 for element [23], the combined system of Aizawa-Inokawa-Mendelson-2006 can rely on the receiver module of Mendelson-2006 to receive signals from Aizawa's sensor and then communicate this data with a PDA. APPLE-1016, 913-914. As shown below, the receiver module of Mendelson-2006 includes a PCB antenna for receiving data from the sensor and a microcontroller ( $\mu\text{C}$ ), or processor, for transmitting the received data to the PDA. *Id.*, 913.

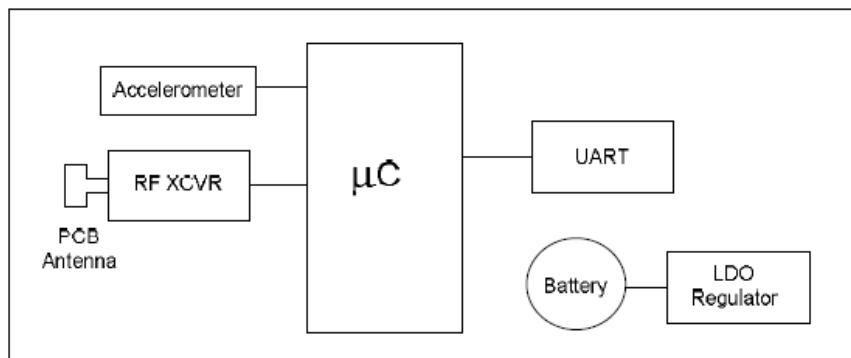

APPLE-1014, FIG. 2

161. Thus, the Aizawa-Inokawa-Mendelson-2006 system includes a processor that is configured to receive physiological signals. *Id.*, 913-914, FIG. 2. And while Mendelson-2006 teaches sending such signals (*i.e.*, physiological

measurement information to a PDA, such as HP's iPAQ Pocket PC that is capable of various "wireless communication protocols," Mendelson-2006 does not disclose whether the PDA is a mobile phone. APPLE-1016, 914.

162. However, as I briefly described above in ¶ 72 with respect to Beyer, Jr., it was indeed well-known during this period that a PDA device as disclosed in Mendelson-2006 was often paired with cellular communication technology to provide a combined PDA/phone that is, essentially, a mobile phone. APPLE-1019, Abstract, 1:6-15; *see also* APPLE-1020, Abstract, FIG. 6, 7:55-63. Such a combined device would have allowed the user to enjoy the combined functionality of a phone and PDA in a single device, which would have been highly convenient since the user only needs to carry around a single device. Moreover, a POSITA would have recognized that "[i]t is often necessary to review the collected data, such as oxygen saturation, pulse rate and pulsatility value at a location remote to the patient being monitored." APPLE-2021, Abstract, FIG. 3. Thus, a POSITA would have looked to PDA devices with cellular connectivity in order to achieve more reliable and convenient patient monitoring. APPLE-1021, FIG. 3.

163. In more detail, Beyer, Jr. teaches "cellular PDA/GPS phones" that enable users "to rapidly call and communicate data among the users by touching display screen symbols and to enable the users to easily access data concerning other users and other database information." APPLE-1021, 1:6-15. As can be seen in the

side-by-side comparison of Beyer, Jr.'s PDA and Mendelson-2006's PDA below, the two devices are highly analogues in both form and function.

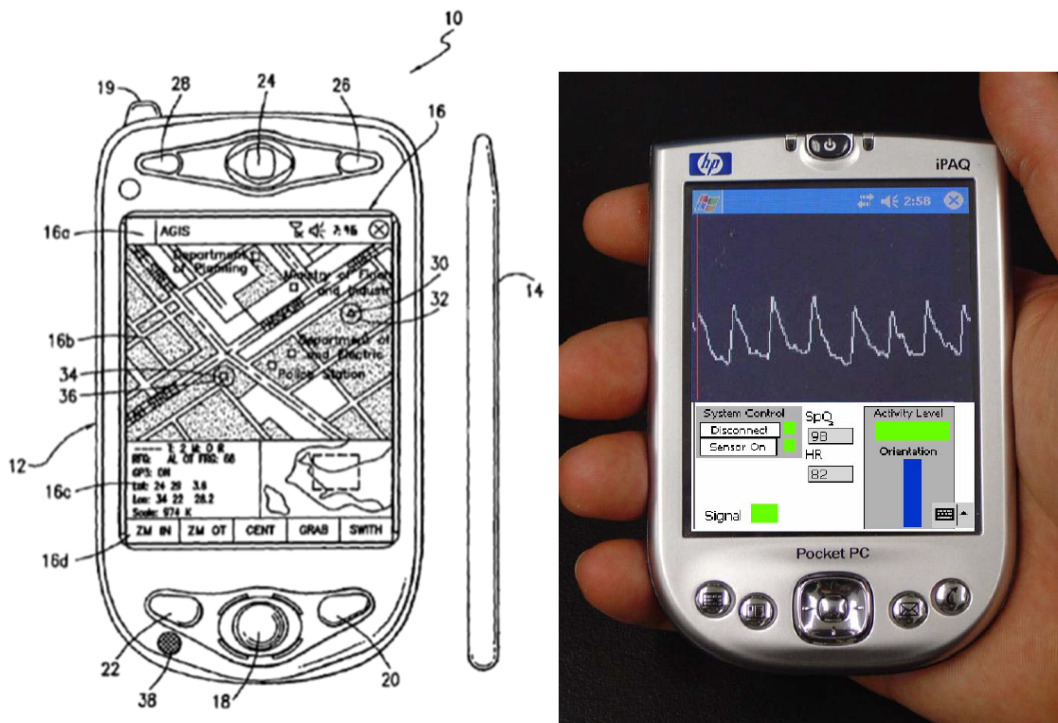

APPLE-1019, FIG. 1 (left); APPLE-1014, FIG. 3 (right)

164. In this context, a POSITA would have found it obvious to use a different PDA than the one mentioned in Mendelson-2006, and would have further found the same to be a routine and conventional design choice. Indeed, using a PDA that is also a mobile phone, as taught by Beyer, Jr. was common practice well before the '265 patent, and there was nothing new or inventive about changing one type of PDA for another.

**XIII. GROUND 2A – Claims 1-4, 6-14, 16-22, and 26-30 Are Rendered Obvious by Mendelson-1988 in View of Inokawa**



## A. Claim 1

**[1pre] A noninvasive optical physiological measurement device adapted to be worn by a wearer, the noninvasive optical physiological measurement device providing an indication of a physiological parameter of the wearer comprising:**

165. Mendelson-1988 discloses “a new optical reflectance sensor suitable for noninvasive monitoring of arterial hemoglobin oxygen saturation with a pulse oximeter.” APPLE-1015, Abstract, 167, 172. Indeed, hemoglobin oxygen saturation is one of the physiological parameters expressly mentioned in the ’265 patent. APPLE-1001, Claim 18. Moreover, the pulse oximeter of Mendelson-1988 is designed to be worn by being attached to the user’s skin. APPLE-1015, 168, 173. There are also other well-known ways of wearing the Mendelson-1988’s sensor, for instance as a wristwatch, a headband, or a helmet, as described by Mendelson in his other publications. APPLE-1016, 913; APPLE-1024, 3017.

**[1a] a plurality of emitters of different wavelengths;**

166. As illustrated below, Mendelson-1988 teaches using two red and two infrared LEDs that are centrally located within the device. APPLE-1015, 168. Red and infrared LEDs emit different wavelengths of light. *Id.*

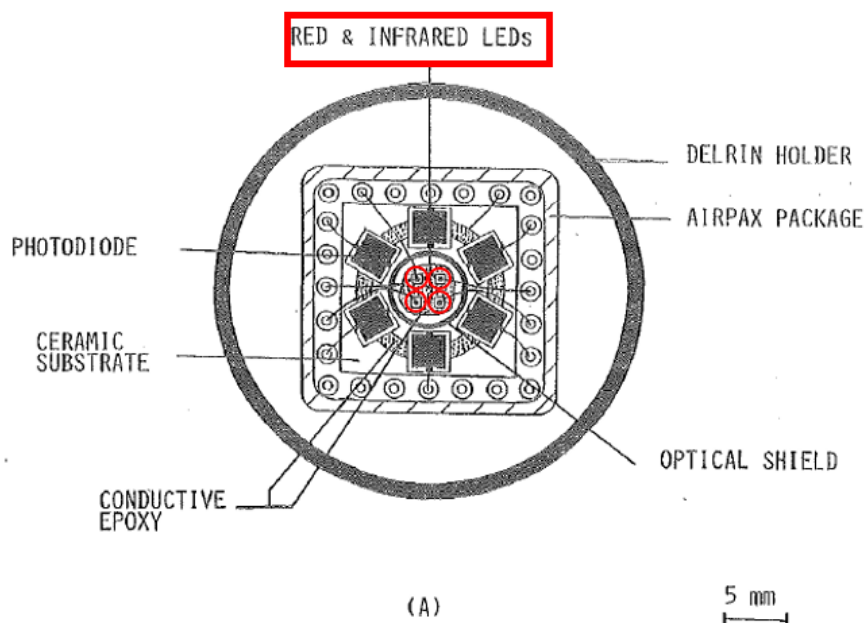

APPLE-1025, FIG. 2(A)

**[1b] a housing having a surface and a circular wall protruding from the surface;**

167. Mendelson-1988 teaches a housing having a surface and a circular wall protruding from the surface as claimed. For example, as shown in the annotated drawings below, the LEDs and photodiode chips of Mendelson-1988 (*i.e.*, emitters and detectors) are mounted on a ceramic substrate (*i.e.*, surface, shown below in purple) and are disposed within an AIRPAX microelectronic package (*i.e.*, housing, shown below in red). APPLE-1015, 168. Mendelson-1988 also teaches a circular wall in the form of “a ring-shaped, optically opaque shield of black Delrin” that is placed around the LEDs to shield the detectors from direct exposure to light from the LED. APPLE-1015, 168.

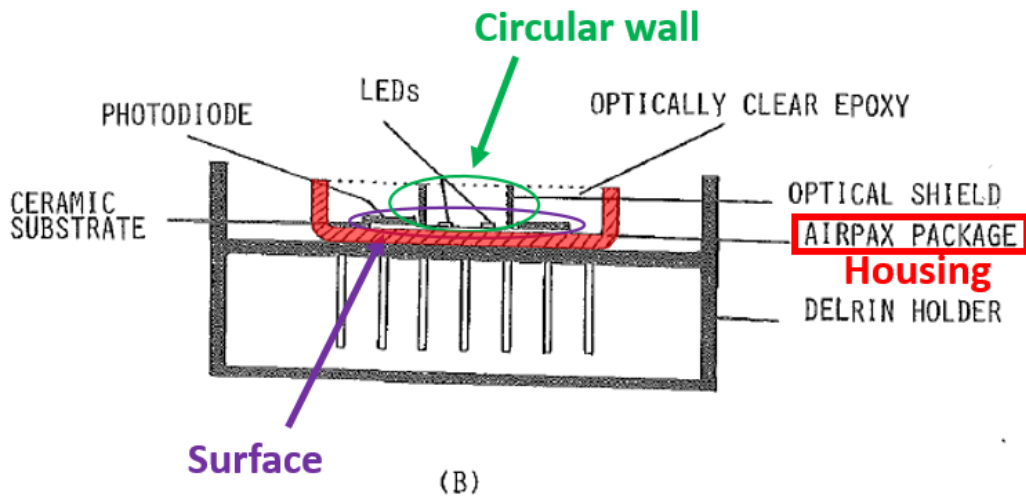

APPLE-1015, FIG. 2(B)

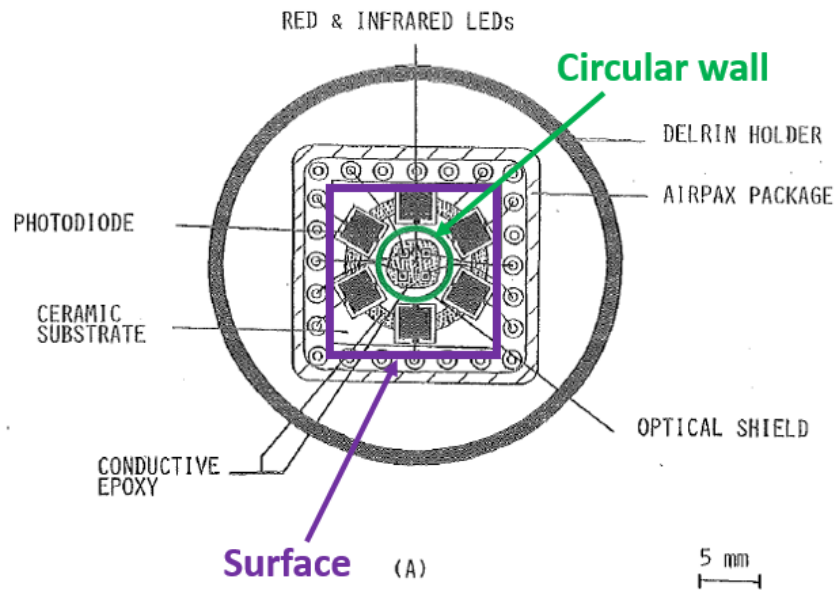

APPLE-1015, FIG. 2(A)

168. Under an alternative mapping, the outer wall of the AIRPAX microelectronic package itself, as indicated below, can be modified to include a circular wall. APPLE-1015, 168.

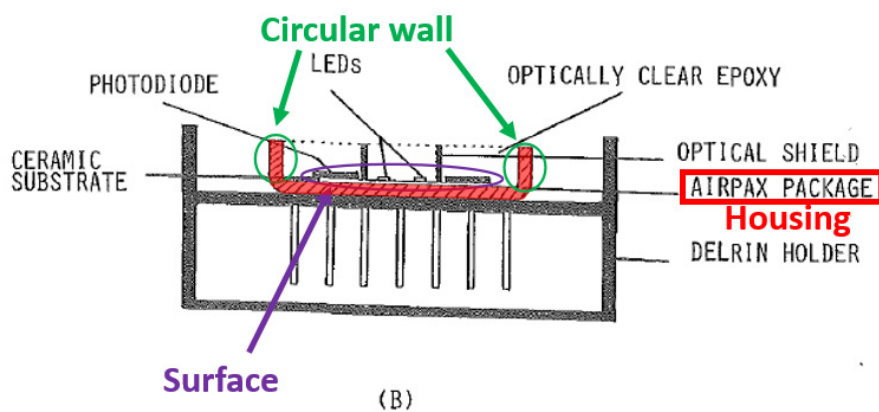

APPLE-1015, FIG. 2(B)

169. However, the particular housing shown in Mendelson-1988 appears to be rectangular and would thus have had a rectangular wall. APPLE-1015, FIG. 2(A). Yet a POSITA would have recognized that microelectronic packaging as used in Mendelson-1988 comes in various shapes and size, for instance rectangular or circular. In fact, a patent authored by the same author of Mendelson-1988 (Dr. Mendelson) shows a similar detector configuration but one that is instead enclosed within a *circular* housing/wall. APPLE-1025, 9:34-36, FIG. 7.



pulses ... which correspond to the red and infrared light intensities reflected from the skin” and are processed to respective photoplethysmographic waveforms.

APPLE-1015, 169. Moreover, the detectors are arranged on the surface provided by the ceramic substrate. APPLE-1015, 168; FIG. 2(B).

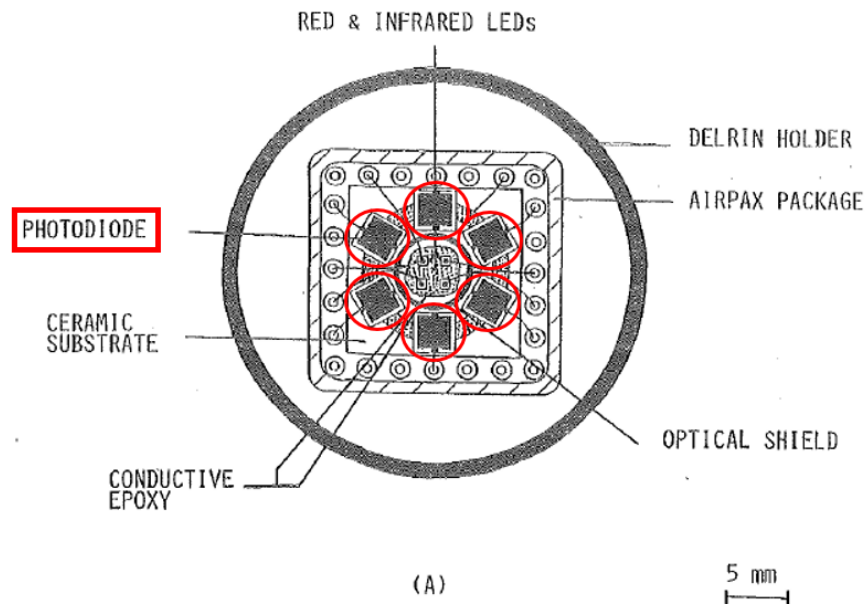

APPLE-1015, FIG. 2(A)

**[1d] a light permeable cover arranged above at least a portion of the housing, the light permeable cover comprising a protrusion arranged to cover the at least four detectors.**

172. As shown below, Mendelson-1988 teaches encapsulating its emitters and detectors, which are within the housing (red), with an optically clear epoxy layer (blue). APPLE-1015, 168. This epoxy layer, therefore, corresponds to a light permeable cover that is arranged above the housing and covers the detectors. *Id.*

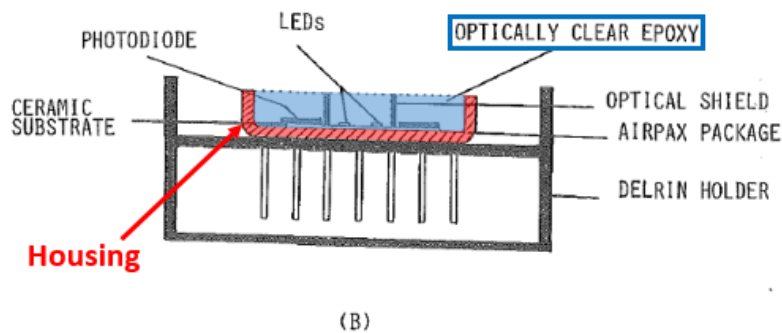

APPLE-1015, FIG. 2(b)

173. However, beyond Mendelson-1988’s disclosure that this cover is made from “optically clear epoxy,” Mendelson-1988 does not provide further details. Among other things, the precise shape of this layer, for instance whether it’s completely flat or slightly curved, is not mentioned. It’s also not mentioned whether this epoxy layer protrudes slightly above the rest of the housing to, for instance, protect the user’s skin from coming in direct contact with any sharp edges of the housing. Yet a POSITA would have recognized that the shape of the epoxy layer may be formed as needed to help further Mendelson’1988’s goal of improving detection efficiency. APPLE-1015, 168, 173.

174. Indeed, as I described above, Inokawa teaches a similarly configured pulse sensor as in Mendelson-1988 but one in which a lens is positioned over the detectors to “increase the light-gathering ability of the LED as well as to protect the LED or [detector].” APPLE-1008, [0015], [0058].

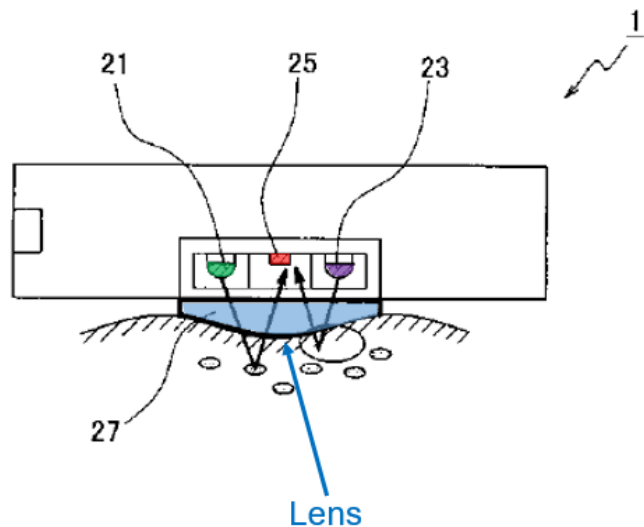

APPLE-1008, FIG. 2

175. Accordingly, a POSITA would have been motivated to incorporate the lens of Inokawa into to cover of Mendelson-1988 in order to increase the light collection efficiency. A POSITA would have been particularly interested in making such a modification because Mendelson-1988 shares a similar goal of maximizing “reflectance photoplethysmographic signals.” APPLE-1015, 173.

The lens of Inokawa provides precisely this benefit to Mendelson’1988’s device by providing a protective cover that further refracts and concentrates the incoming light beams to thereby enhance the light collection efficiency and, by extension, the signal to noise ratio. APPLE-1008, [0015], [0058].

176. Indeed, as illustrated below, the device resulting from this combination of Mendelson-1988 and Inokawa would have modified the flat epoxy cover (left) with



a curved one as per Inokawa (right) to thereby “increase the light-gathering ability.” APPLE-1008, [0015].

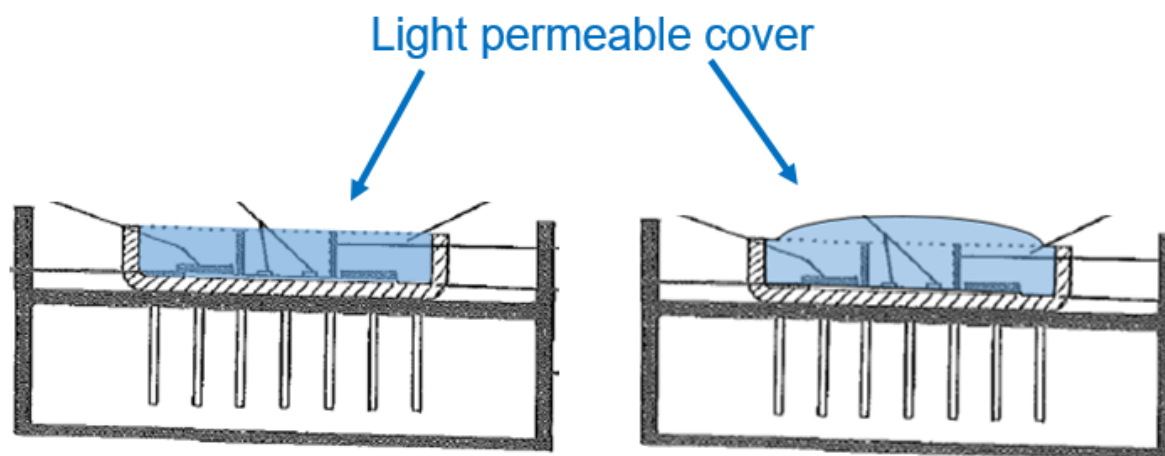

APPLE-1015, FIG. 2(B)

177. A POSITA would have understood how to implement Inokawa’s lens-shaped cover in Mendelson-1988 with a reasonable expectation of success based, among other things, on the significant overlap between these two references.

Indeed, the above-described modification would require only routine knowledge of sensor design and assembly, which were well within the skill of a POSITA prior to the Critical Date.

178. Moreover, a POSITA would have easily understood how to modify the epoxy layer of Mendelson-1988 to achieve the desired shape. Indeed, Nishikawa, shown below, teaches that a clear epoxy layer as in Mendelson-1988 can be molded into a lens shape. APPLE-1023, [0022], [0032], [0035].

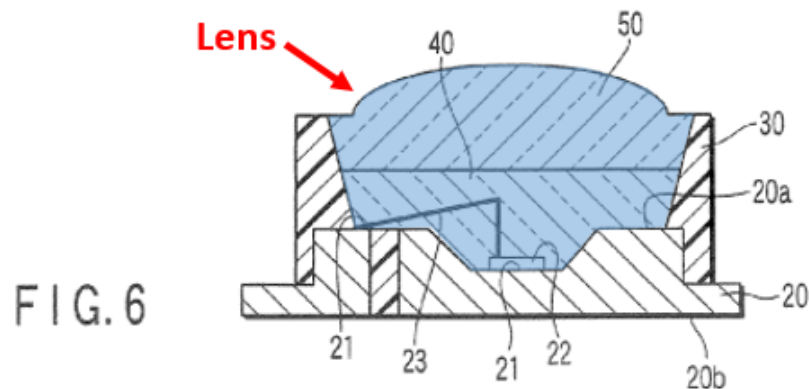

APPLE-1023, FIG. 6

179. Notably, both the optical encapsulation layer of Mendelson-1988 and the lens layer of Nishikawa are made from the same material, optically clear epoxy, and thus the interface between the encapsulation portion and the lens portion will not adversely affect the optical performance of the modified system. APPLE-1023, [0037]. Thus, to help achieve Mendelson-1988’s and Inokawa’s shared goal of improving light collection efficiency, a POSITA would have been motivated and able to modify Mendelson-1988’s light permeable cover to have a lens shape as per Inokawa with a reasonable expectation of success.

180. Here, I note that the claimed light permeable cover (“LPC”) may be mapped in two different ways to the Mendelson-1988’s epoxy layer as modified by Inokawa. First, the entire combined epoxy structure—*i.e.*, the sealing portion and the lens portion—may be viewed to be the LPC, as shown below. The LPC as described in the ’265 patent, for example with regard to FIG. 14D, appears to

envision a similar two-part structure comprising a flat cover portion and a protruded lens portion. APPLE-1001, FIG. 14D.

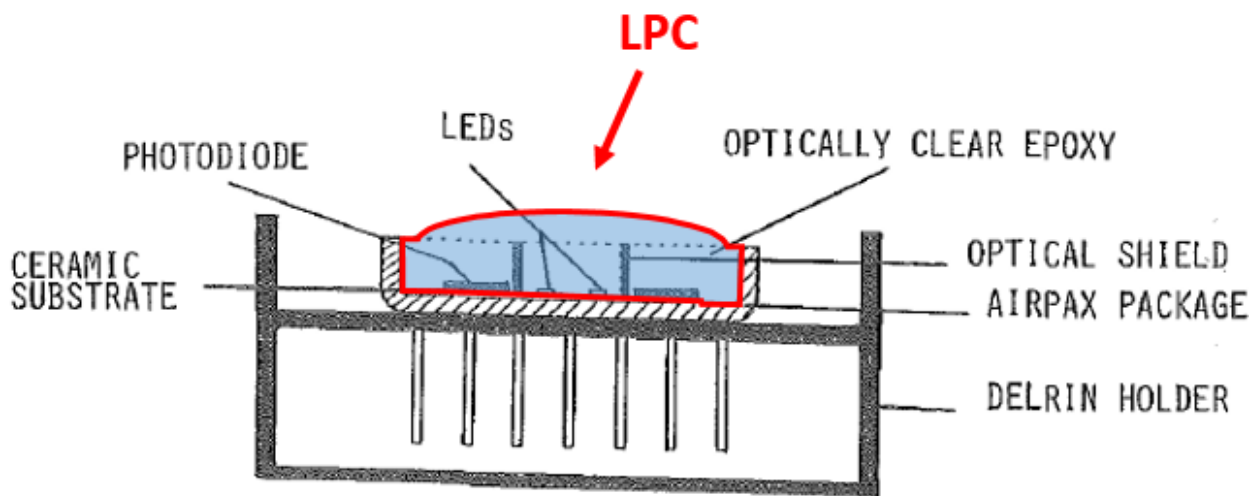

APPLE-1015, FIG. 2(B)

181. Second, only the top lens portion, which lies above the underlying sealing portion, may be viewed to be the LPC having a protrusion. In forming this two-part structure, a POSITA would have been able to use the top portion of the housing (indicated below in purple), as in Nishikawa, to help form the LPC portion on top of the sealing portion. APPLE-1023, [0034]-[0038], FIGS. 5-6.

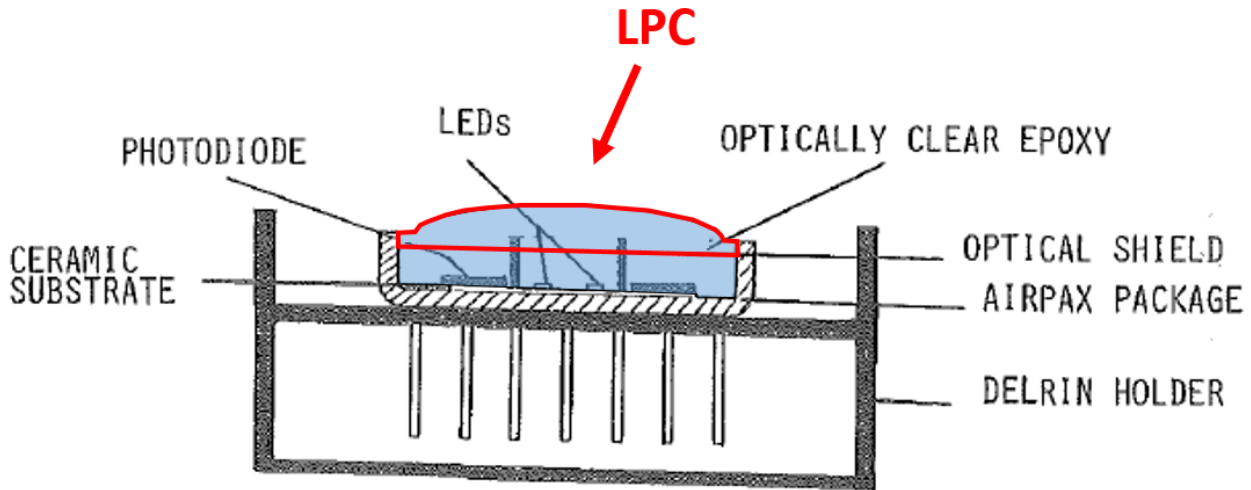

APPLE-1015, FIG. 2(B)

**B. Claim 2**

**[2] The noninvasive optical physiological measurement device of claim 1, wherein the light permeable cover is attached to the housing and forms an airtight or substantially airtight seal enclosing the at least four detectors.**

182. As explained above with respect to element [1d] and shown below, the modified LPC in the Mendelson-1988-Inokoawa combination, under either mapping, completely encapsulates and seals the detectors.

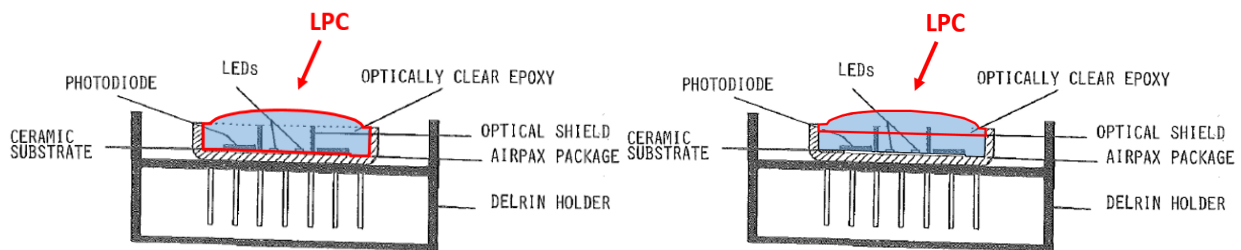

APPLE-1015, FIG. 2(B)

183. A POSITA would have recognized or found it obvious that such an encapsulating layer would provide a substantially airtight seal. APPLE-1023, Abstract. Moreover, a POSITA would have recognized that a body-worn device as

in Mendelson-1988 would be airtight or substantially airtight since, otherwise, condensation, sweat, and other undesirable elements may enter and damage the internal electronics. Thus, a POSITA would have recognized or found it obvious that the light permeable cover of Mendelson-1988-Inokawa would form an airtight or substantially airtight seal enclosing the at least four detectors.

### C. Claim 3

**[3] The noninvasive optical physiological measurement device of claim 2, wherein the circular wall creates a gap between the surface and the light permeable cover.**

184. As I explained above for [1d], the analysis for which I fully incorporate herein, the Mendelson-1988-Inokawa combination includes, under the second mapping, an LPC that is separated from the surface by a gap.

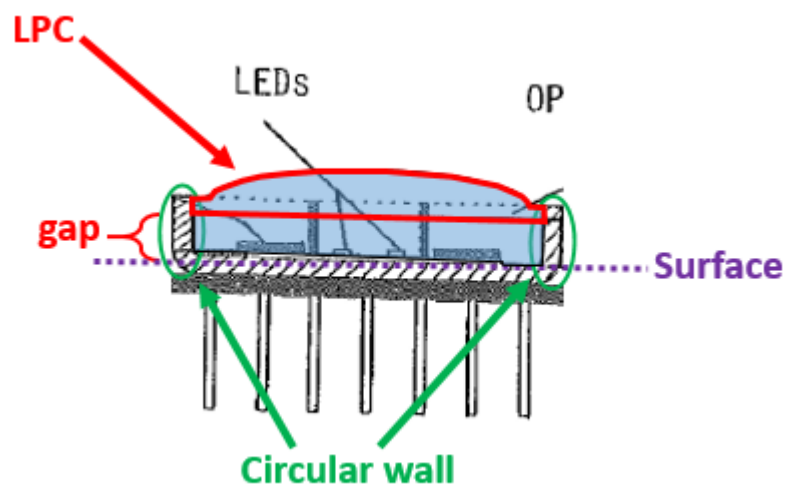

APPLE-1015, FIG. 2(B)

185. Indeed, the LPC as identified above is separated in space from the surface and, therefore, a gap exists between the LPC and the surface. *See* APPLE-1017, 515 (defining “gap” as “a separation in space”).

186. Further, the size of the gap above would be defined, in part, by a wall of the housing that surrounds the epoxy structure and serves as a mold that define its overall height and, by extension, the size of the gap. APPLE-1023, [0034]-[0038], FIGS. 5-6.

187. Additionally, as I explained above in ¶¶ 167-170 for element [1b], the outer wall of the AIRPAX package can be circular, thus providing a circular wall as required in this claim. APPLE-1025, FIG. 7, 9:34-36.

#### **D. Claim 4**

**[4] The noninvasive optical physiological measurement device of claim 2, wherein the housing provides noise shielding for the at least four detectors.**

188. As explained above with respect to [1b], Mendelson-1988 teaches “a ring-shaped, optically opaque shield of black Delrin [that is] placed between the LEDs and the photodiode chips.” APPLE-1015, 168, FIGS. 2(a), 2(b). Thus, this shield, which is part of Mendelson-1988’s housing, noise shielding by blocking unwanted light from reaching the detectors. *Id.* A POSITA would also have additionally recognized that the entire AIRPAX package of Mendelson-1988 must be opaque and thus able to block unwanted light (*i.e.*, light noise) coming in from the side of the housing into the detector area. APPLE-1015, 168, FIG. 2.

**E. Claim 6**

**[6] The noninvasive optical physiological measurement device of claim 3, wherein the protrusion comprises a continuous protrusion.**

189. As explained above with respect to [1d], incorporated herein, the Mendelson-1988-Inokawa combination provides a light permeable cover having a protrusion. APPLE-1015, 168, FIG. 2(b); APPLE-1008, [0015], [0058], FIG. 2.

190. Moreover, as shown below, the protrusion of Inokawa, as incorporated into Mendelson-1988, is continuous. APPLE-1008, [0015], [0058], FIG. 2.

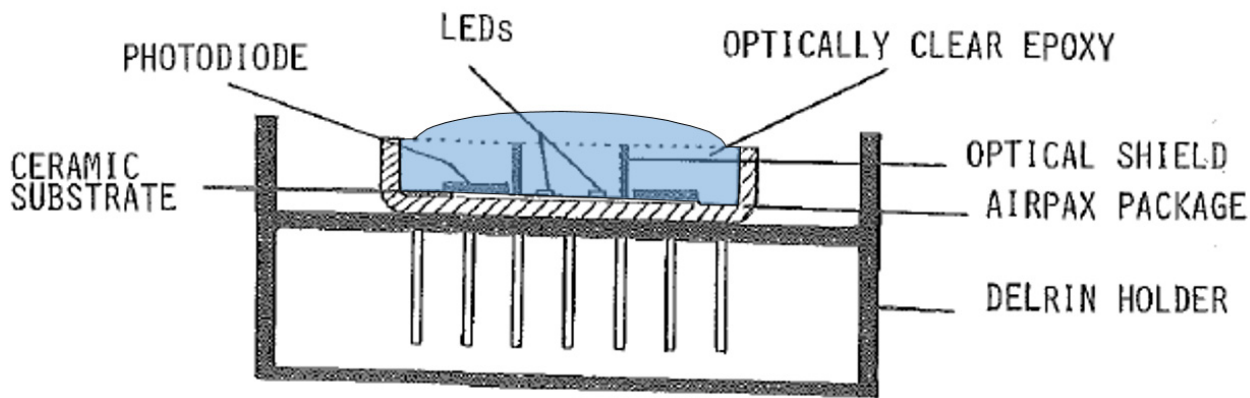

APPLE-1015, FIG. 2(B)

**F. Claim 7**

**[7] The noninvasive optical physiological measurement device of claim 6, wherein the continuous protrusion comprises a convex protrusion.**

191. As explained above with respect to [1d], incorporated herein, the Mendelson-1988-Inokawa combination provides a light permeable cover having a protrusion. APPLE-1015, 168, FIG. 2(b); APPLE-1008, [0015], [0058], FIG. 2.

192. Moreover, as shown below, the protrusion of Inokawa, as incorporated into Mendelson-1988, is convex. APPLE-1008, [0015], [0058], FIG. 2.

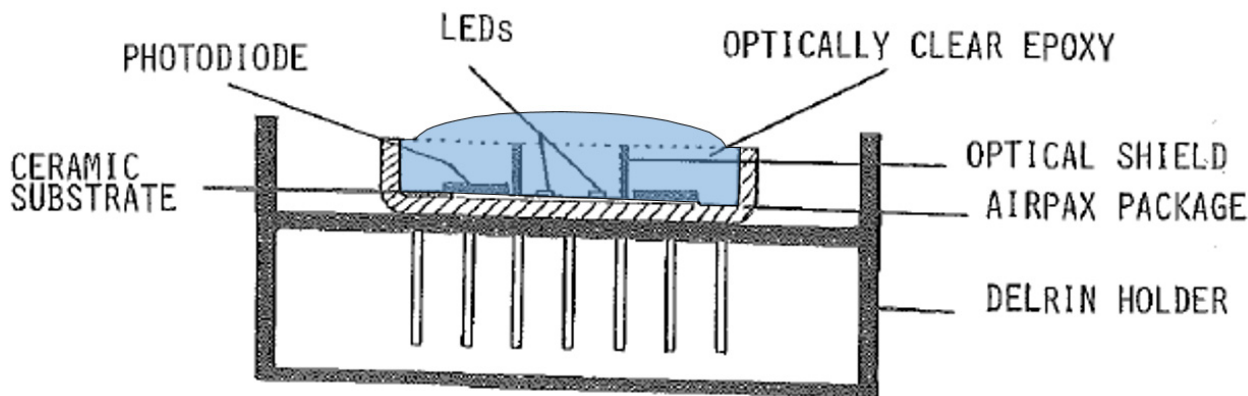

APPLE-1015, FIG. 2(B)

### G. Claim 8

**[8] The noninvasive optical physiological measurement device of claim 6, wherein the light permeable cover is comprised of a rigid material.**

193. As explained above with respect to [1d], incorporated herein, the Mendelson-1988-Inokawa combination provides a light permeable cover having a protrusion. APPLE-1015, 168, FIG. 2(b); APPLE-1008, [0015], [0058], FIG. 2.

194. Here, the light permeable cover of Mendelson-1988 is made of cured resin (*i.e.*, epoxy), which a POSITA would understand to be a rigid material. APPLE-1015, 168, FIG. 2. To the extent Patent Owner argues—falsely—that a cured, encapsulating epoxy resin of Mendelson-1988-Inokawa is not rigid, a POSITA would have found it obvious to use a rigid material to form the lens/protrusion in



the Mendelson-1988-Inokawa combination because a rigid lens better preserves its shape and, thereby, offers improved optical performance relative to a pliable lens that would hold its shape well, especially when pressed against the skin during use. Such a rigid lens would provide improved optical performance and light-gathering ability compared to a non-rigid lens, the latter of which may partially or completely lose its shape during use, thereby degrading its optical properties.

#### H. Claim 9

**[9] The noninvasive optical physiological measurement device of claim 8, wherein the light permeable cover is configured to be positioned between the at least four detectors and tissue of a user when the noninvasive optical physiological measurement device is worn by the user.**

195. As explained above with respect to [1d], incorporated herein, the Mendelson-1988-Inokawa combination provides a light permeable cover having a protrusion. APPLE-1015, 168, FIG. 2(b); APPLE-1008, [0015], [0058], FIG. 2.

196. Moreover, the pulse oximeter of Mendelson-1988 is designed to be placed directly on the user's skin, and therefore, the modified LPC, which covers the detectors, would be positioned between the detectors and the tissue. APPLE-1015, 169.

#### I. Claim 10

**[10] The noninvasive optical physiological measurement device of claim 9, wherein the light permeable cover is configured to press against and at least partially deform tissue of the user when the noninvasive optical physiological measurement device is worn by the user.**

197. As explained above with respect to [1d], the Mendelson-1988-Inokawa combination provides a light permeable cover that is positioned on the skin of the user when worn. APPLE-1015, 168, FIG. 2(b); APPLE-1008, [0015], [0058], FIG. 2.2. Moreover, the light permeable cover of Mendelson-1988 is designed to be attached directly to the user's skin. APPLE-1015, 169. Being pressed into the skin in this manner will cause at least the tissue at least partially deform because the skin is more pliable than the light permeable cover, for example as demonstrated below by Inokawa where it can be seen that the user's tissue has deformed around the protruded surface of the cover.

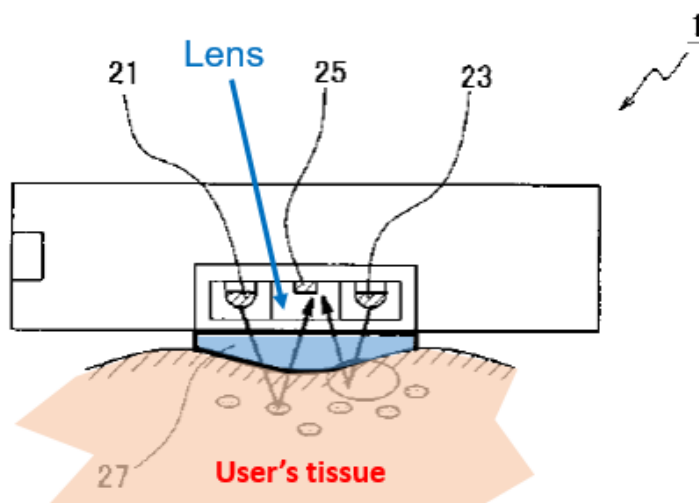

APPLE-1008, FIG. 2

#### J. Claim 11

**[11] The noninvasive optical physiological measurement device of claim 10, wherein the light permeable cover is configured to act as a tissue shaper and conform tissue of the user to at least a portion of an external surface shape of**

**the light permeable cover when the noninvasive optical physiological measurement device is worn by the user.**

198. As explained above with respect to [10], the light permeable cover in the Mendelson-1988-Inokawa combination deforms the tissue of the user around the lens/protrusion during use. APPLE-1015, 169; APPLE-1008, FIG. 2. In this way, the lens/protrusion acts as a tissue shaper that helps conform the tissue of the user to an external surface of the lens/protrusion when the device is worn by the user.

*Id.* As explained for [10], this happens because a protruded surface that is more rigid than the skin is being pressed into the skin and, accordingly, the more pliable skin will at least partially deform to conform to the rigid protrusion. *Id.*

#### **K. Claim 12**

**[12] The noninvasive optical physiological measurement device of claim 11, wherein the light permeable cover is configured to reduce a mean path length of light traveling to the at least four detectors.**

199. Regarding the reduction of mean path length, the '265 patent mentions, in the context of a transmittance-type device, that using a protruded cover to deform the skin can cause “the mean optical path length from the emitters to the detectors can be reduced and the accuracy of blood analyte measurement can increase.”

APPLE-1001, 20:25-20, FIG. 5. Although the '265 patent is silent regarding how such path reduction would apply in a reflectance-type sensor, a POSITA still would have recognized that an analogous effect can be achieved the Mendelson-1988-Inokawa combination.

200. In more detail, I noted above for [1d] how the lens/protrusion of Inokawa, which is used to modify Mendelson-1988's epoxy cover, provides a condensing function by refracting the light passing through it. APPLE-1008, [0015], [0058]. As demonstrated through my drawings below, where the left figure shows the length of non-refracted light and the right figure shows the length of refracted light, such refraction of the incoming reflected light can shorten the path of the light before it reaches the detector. This is because the incoming light is "condensed" toward the center. APPLE-1008, [0015], [0058]. Thus, as demonstrated by the drawings below, both the total length of travel as well as the length through the tissue can be reduced.

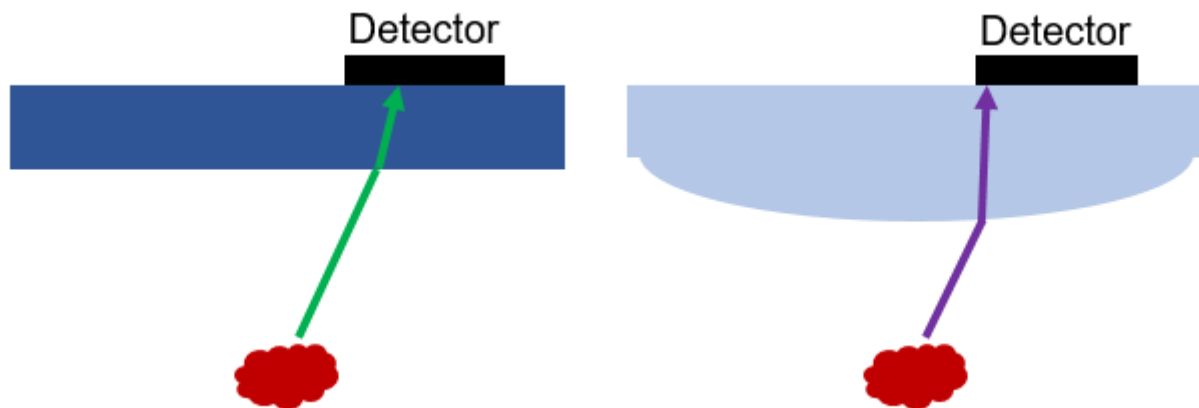

201. Laying these two drawings on top of each other, as shown below, the shortened path length within the tissue for the purple (refracted) line can be clearly seen compared to the path length within the tissue of the green (non-refracted) line. The shortened *total* path length of the purple line compared to the green line can also be seen. Accordingly, the Mendelson-1988-Inokawa combination, through its

use of a condensing lens between the tissue and the detectors, serves to reduce a mean path length of light traveling to the at least four detectors

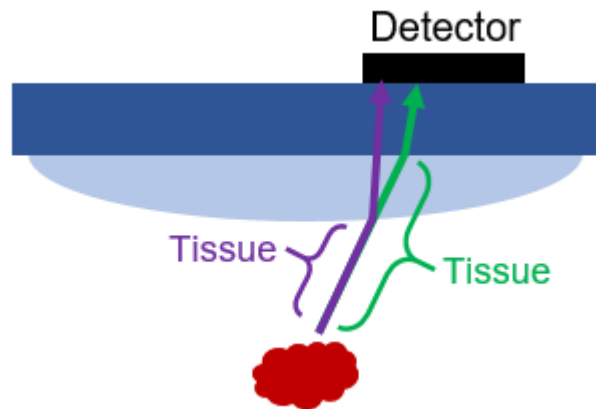

**L. Claim 13**

**[13] The noninvasive optical physiological measurement device of claim 11, wherein the at least four detectors are evenly spaced from one another.**

202. As explained above with respect to [1c], Mendelson-1988 teaches at least for detectors. APPLE-10015, 168, FIG. 2(a). Further, as shown below, the multiple detectors of Mendelson-1988 are evenly spaced from one another. *Id.*

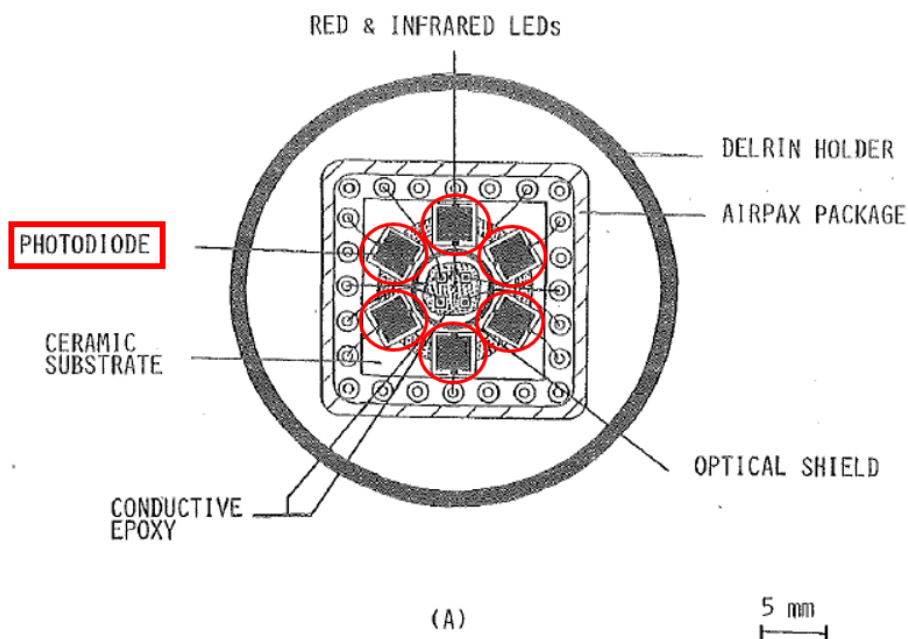

**M. Claim 14**

**[14] The noninvasive optical physiological measurement device of claim 1, wherein the light permeable cover is configured to reduce a mean path length of light traveling to the at least four detectors.**

203. As I explained above for [12], the analysis for which I fully incorporate herein, the Mendelson-1988-Inokawa combination includes a light permeable cover (*i.e.*, lens) that is configured to reduce a mean path length of light traveling to the at least four detectors. APPLE-1008, [0015], [0058].

**N. Claim 16**

**[16] The noninvasive optical physiological measurement device of claim 13, wherein the light permeable cover is configured to increase a signal strength per area of the at least four detectors.**

204. As I explained above with respect to [1d], the Mendelson-1988-Inokawa combination includes provides a light permeable cover with a convex protrusion that acts as a lens, thereby enhancing the device's light-gathering ability. APPLE-1008, [0015], FIG. 2. Indeed, a POSITA would have known that a lens, as in Inokawa and as incorporated into Mendelson-1988, would condense incoming light onto the detectors, thus increasing the signal to noise ratio as well as the signal strength per area of the detectors (since each detector area will receive more incoming light signals).

**O. Claim 17**

**[17] The noninvasive optical physiological measurement device of claim 1, wherein the physiological parameter is pulse rate.**

205. Mendelson-1988's pulse oximeter detects photoplethysmograms, which includes pulse rate information. APPLE-1015, 168-170. Indeed, the photoplethysmogram below from Mendelson-1988 shows distinct pulses that correspond to the user's pulse rate. *Id.*

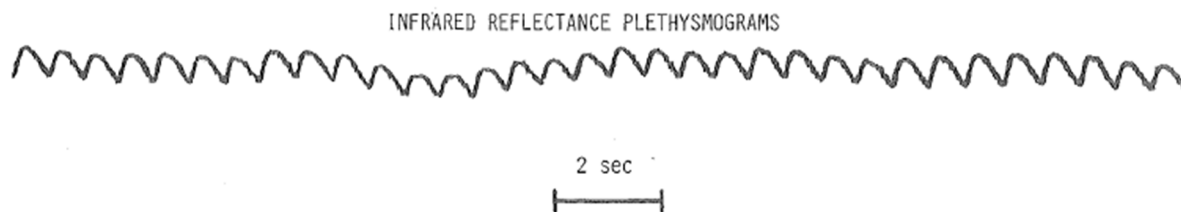

APPLE-1015, FIG. 1

**P. Claim 18**

**[18] The noninvasive optical physiological measurement device of claim 1, wherein the physiological parameter is at least one of: glucose, oxygen, oxygen saturation, methemoglobin, total hemoglobin, carboxyhemoglobin, or carbon monoxide.**

206. The pulse oximeter of Mendelson-1988 is designed to measure, among other things, "hemoglobin oxygen saturation in arterial blood (SpO<sub>2</sub>).” APPLE-1015, 167, Abstract.

**Q. Claim 19**

**[19] The noninvasive optical physiological measurement device of claim 1, wherein the noninvasive optical physiological measurement device is a disposable or a reusable device.**

207. As an initial matter, most, if not all, sensing devices will be either disposable or reusable. If the device is meant to be discarded after a single use, then a POSITA would understand it to be disposable. If the device is designed to be used multiple times, then a POSITA would understand it to be reusable. In particular regarding Mendelson-1988's device, a POSITA would have recognized that it would be reusable because, among other things, it will likely be very expensive to use such a device one time and discard after each use. Indeed, Mendelson-1988 mentions testing on multiple participants, thereby suggesting the device's reusable nature. APPLE-1015, 169-170. A POSITA would have recognized that such a device for long-term use is typically a reusable device. To the extent Patent Owner argues that Mendelson-1988 is designed to be thrown away after being used, then Mendelson-1988's device would be disposable, thereby still satisfying this limitation.

#### **R. Claim 20**

**[20] The noninvasive optical physiological measurement device of claim 1, wherein a first detector is arranged spaced apart from a second detector, and a third detector arranged spaced apart from a fourth detector.**

208. As explained above with respect to [1c] and [13], incorporated herein, the Mendelson-1988-Inokawa combination includes at least four detectors. APPLE-1015, 168, FIG. 2(A). Moreover, as illustrated below, there are at least four detectors in Mendelson-1988 that are spaced from one another such that a first



detector is spaced apart from a second detector, and a third detector is spaced apart from a fourth detector. I've identified four of the detectors in Mendelson-1988 as 1<sup>st</sup>, 2<sup>nd</sup>, 3<sup>rd</sup>, and 4<sup>th</sup>, but this particular identification is arbitrary and other numbering schemes may be used.

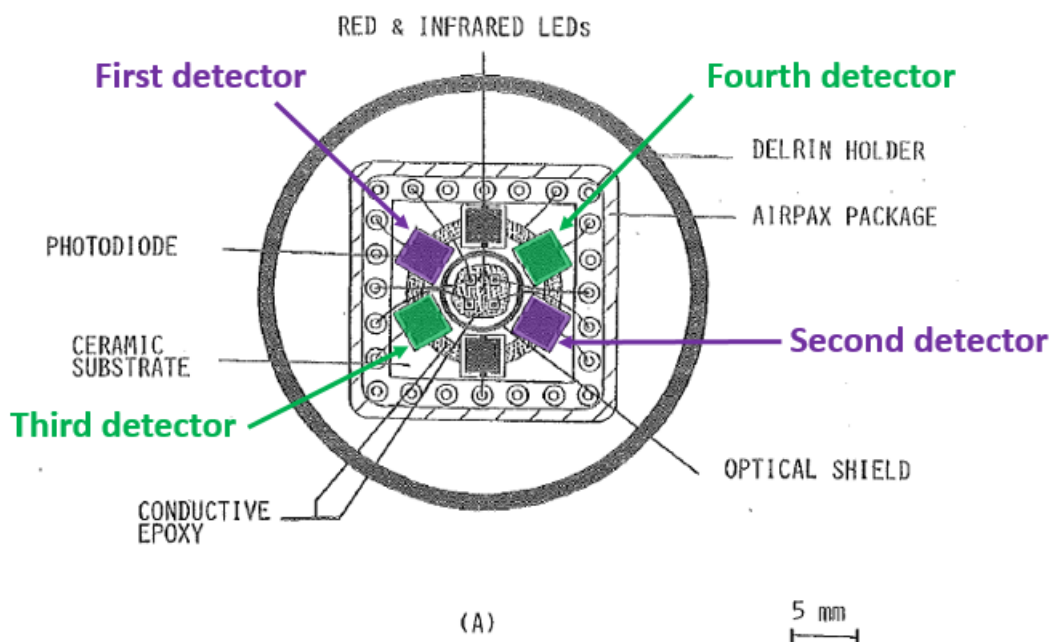

APPLE-1015, FIG. 2(A)

**S. Claim 21**

**[21] The noninvasive optical physiological measurement device of claim 20, wherein the first detector is arranged across a central axis from the second detector and the third detector is arranged across the central axis from the fourth detector, wherein the first, second, third and fourth detectors form a cross pattern about the central axis.**

209. The Mendelson-1988-Inokawa combination discloses this element. For example, referring to the numbering scheme I used in my analysis of claim 20, and as shown below, the four identified detectors of Mendelson-1988 are arranged such

that the first detector is arranged across a central axis (shown in red) from the second detector and the third detector is arranged across the central axis from the fourth detector. APPLE-1015, FIG. 2(a). Moreover, as I show below in blue, the first, second, third and fourth detectors form a cross pattern about the central axis.

*Id.*

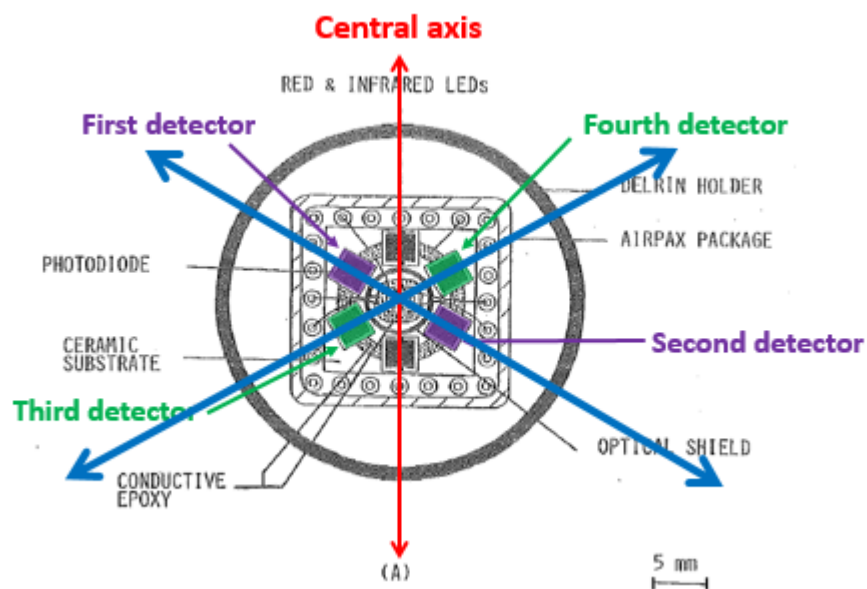

APPLE-1015, FIG. 2(A)

#### T. Claim 22

**[22] The noninvasive optical physiological measurement device of claim 20, wherein the noninvasive optical physiological measurement device provides a variation in optical path length to the at least four detectors.**

210. As explained above with respect to [12], incorporated herein, the

Mendelson-1988-Inokawa combination provides a lens/protrusion that refracts incoming light and thereby changes the optical path length to the detectors.

APPLE-1008, [0015], [0058]. Moreover, since the process for getting light into and out of the tissue depends on scattering, light entering and returning from the tissue will follow many different random paths, with many different lengths.

Additionally, since the emitter is not a point source, and the detector has a finite area of detection, there are multiple paths from a portion of the emitter to a portion of the detector. And since there are 2 emitters of each wavelength, there are two distinct sources for the light, and the many combinations of the individual emitters and detectors creates a large variety of possible paths. These rays propagate into the tissue and some find their way back to some portion of the surface of the detectors. Thus, aside from the variations in the path associated with the randomness of the scattering, there is also a variation associated with the finite area of these elements. Accordingly, there will be a variation in optical path length to the four detectors.

#### **U. Claim 26**

**[26pre] A noninvasive optical physiological measurement device adapted to be worn by a wearer providing an indication of a physiological parameter of the wearer comprising:**

211. For reasons I discussed above in ¶ 165 with respect to element [1pre], herein incorporated by reference, this limitation is rendered obvious by the Mendelson-1988-Inokawa combination. APPLE-1015, Abstract, 167, 168, 172, 173.

**[26a] a plurality of emitters of different wavelengths;**

212. For reasons I discussed above in ¶ 166 with respect to element [1a], herein incorporated by reference, this limitation is rendered obvious by the Mendelson-1988-Inokawa combination. APPLE-1015, FIG. 2(A), 168.

**[26b] a circular housing comprising a surface with a raised edge;**

213. For reasons I discussed above in ¶¶ 167-170 with respect to element [1b], herein incorporated by reference, Mendelson-1988 teaches a ceramic substrate (*surface*) that is housed within an AIRPAX microelectronic package (*housing*). APPLE-1015, 168.

214. Moreover, as illustrated below, Mendelson-1988's housing a raised edge:

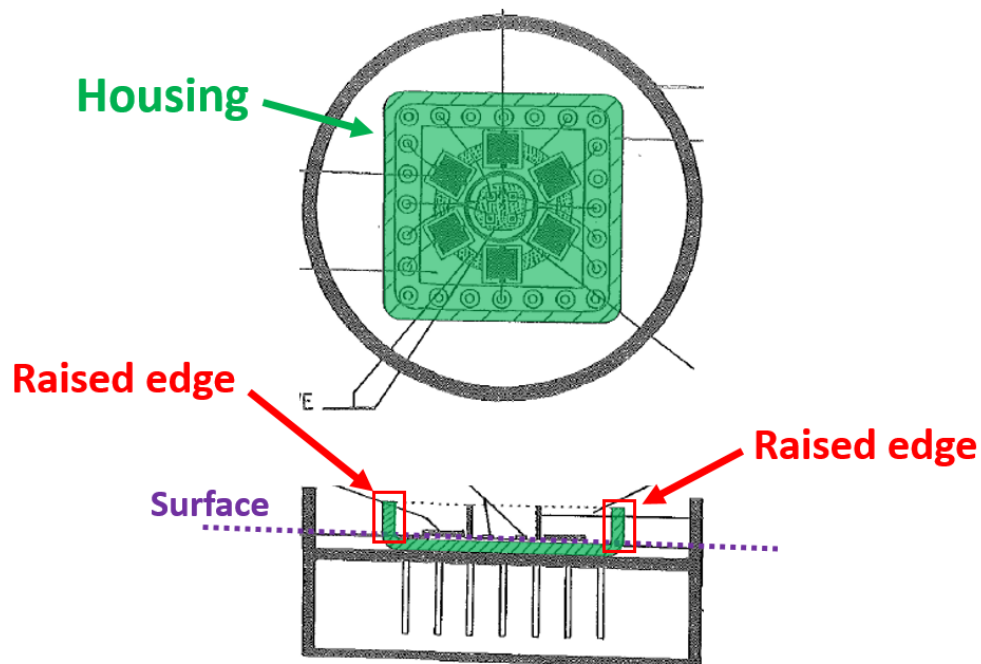

APPLE-1015, FIGS. 2(a) and 2(b)

215. This claim, however, requires the housing to be “circular,” and the housing shown in Mendelson-1988 appears to be rectangular. APPLE-1015, FIG. 2(A).

Yet a POSITA would have recognized that microelectronic packaging as used in Mendelson-1988 comes in various shapes and size, for instance rectangular or circular. In fact, a patent authored by the same author of Mendelson-1988 (Dr. Mendelson) shows a similar detector configuration but one that is instead enclosed within a *circular* housing. APPLE-1025, 9:34-36, FIG. 7.

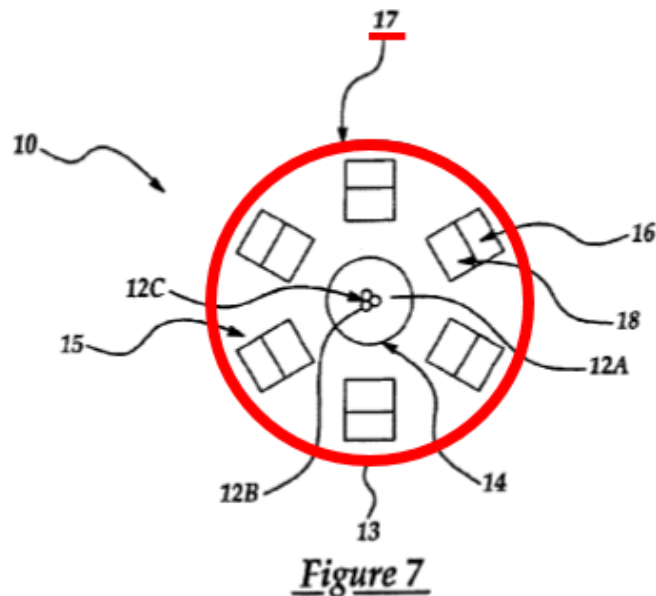

APPLE-1025, FIG. 7, 9:34-36

216. A POSITA would have found it obvious and actually quite routine to use a differently shaped housing, namely a circular one. *Id.* Indeed, using a circular housing having a circular wall, as evidenced by Mendelson-'799, was common practice well before the Critical Date, and there was nothing new or inventive about changing one housing shape for another.

**[26c] at least four detectors arranged on the surface, wherein a first detector is arranged spaced apart from a second detector, and a third detector arranged spaced apart from a fourth detector; and**

217. For reasons I discussed above in ¶¶ 171, 202 with respect to elements [1c] and [13], herein incorporated by reference, this limitation is rendered obvious by the Mendelson-1988-Inokawa combination. APPLE-1015, 169, FIG. 2(A).

**[26d] a cover of the circular housing comprising a lens portion, the lens portion comprising a protrusion in optical communication with the at least four detectors,**

218. For reasons I discussed above in ¶¶ 172-181 with respect to element [1d], herein incorporated by reference, this limitation is rendered obvious by the Mendelson-1988-Inokawa combination. APPLE-1015, FIG. 2(B); APPLE-1008, [0015], FIG. 2. In more detail, because reflected light that is received by Mendelson-1988's detectors must first pass through the lens portion, as provided by Inokawa, the lens portion is in optical communication with the at least four detectors. APPLE-1015, FIG. 2, 168.

**[26e] wherein the at least four detectors are configured to output one or more signals responsive to light from the one or more light emitters attenuated by body tissue, the one or more signals indicative of a physiological parameter of the wearer.**

219. For reasons I discussed above in ¶ 171 with respect to element [1c], herein incorporated by reference, this limitation is rendered obvious by the Mendelson-1988-Inokawa combination. APPLE-1015, 169.

## V. Claim 27

**[27] The noninvasive optical physiological measurement device of claim 26, wherein the first detector is arranged across a central axis from the second detector and the third detector is arranged across the central axis from the fourth detector, wherein the first, second, third and fourth detectors form a cross pattern about the central axis.**

220. For reasons I discussed above in ¶ 209 with respect to element [21], herein incorporated by reference, this limitation is rendered obvious by the Mendelson-1988-Inokawa combination. APPLE-1015, FIG. 2(a).

#### **W. Claim 28**

**[28] The noninvasive optical physiological measurement device of claim 26, wherein the at least four detectors are arranged in a grid pattern such that the first detector and the second detector are arranged across from each other on opposite sides of a central point along a first axis, and the third detector and the fourth detector are arranged across from each other on opposite sides of the central point along a second axis which is perpendicular to the first axis.**

221. For reasons I discussed above in ¶ 209 with respect to element [21], herein incorporated by reference, and as shown below, this limitation is rendered obvious by the Mendelson-1988-Inokawa combination. APPLE-1015, FIG. 2(A). In more detail, as illustrated below, the detectors are arranged in a grid pattern relative to a central point, and the first/second axes, for example as identified below, are nearly perpendicular to each other. Moreover, because of the high symmetry (rotations and reflections) of the arrangement of four detectors with respect to the central point, there are many grids that can be drawn which would meet the limitations of this claim element. The illustration provided is just one of many possible grids. This symmetry provides many obvious and useful benefits, including

reduced sensitivity to the location of the device relative to the anatomy, manufacturing convenience, and assembly convenience.

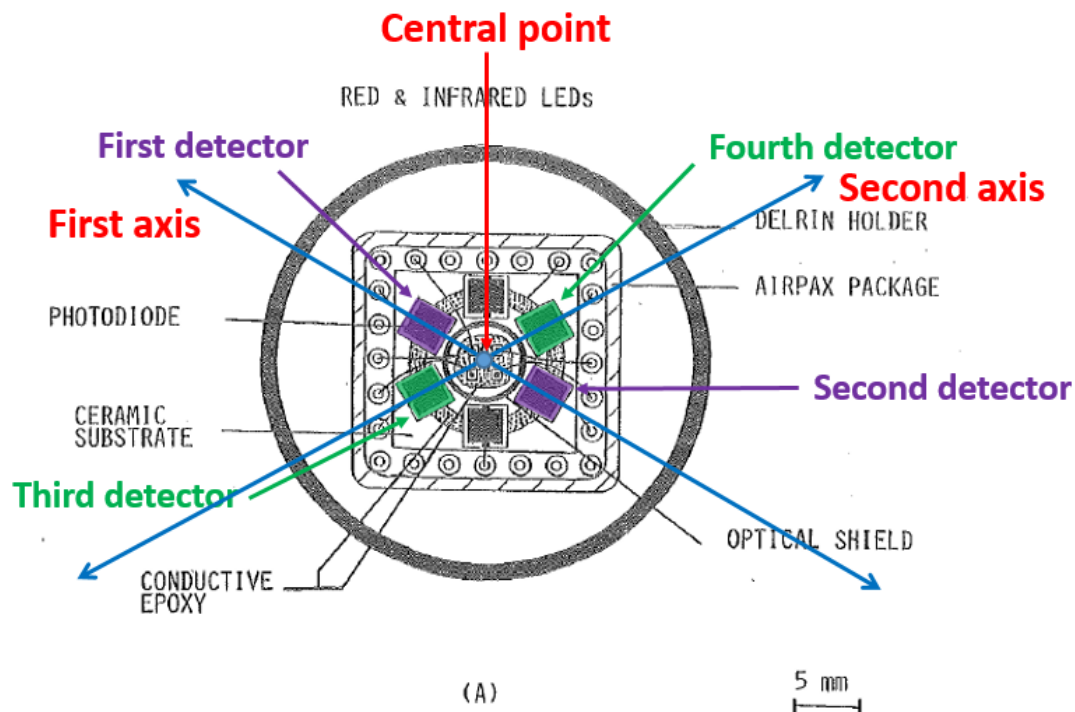

APPLE-1015, FIG. 2(A)

222. While the first and second axes as shown above form a cross pattern, they are not shown to be completely perpendicular to each other. Here, I note that Mendelson-1988 does not indicate that its system only works with six detectors. APPLE-1015, 168. In fact, Mendelson 1988 explains that “the total amount of backscattered light that can be detected by the reflectance sensor is directly proportional to the number of photodetectors.” *Id.* Accordingly, a POSITA would have recognized that different numbers of detectors may be readily chosen depending on the detection requirements of a particular system. For example, two



more detectors may be added—to make 8 total detectors—by a POSITA that is seeking to achieve enhanced light detection capabilities since increasing the number of detectors will increase the amount of light being collected. Similarly, a POSITA seeking to achieve reduced power consumption may remove two detectors to achieve 4 total detectors. In either case, with 8 or 4 detectors instead of 6, the resulting detector configuration in which the detectors remain equally spaced apart would result in perpendicular axes as claimed, as shown below.

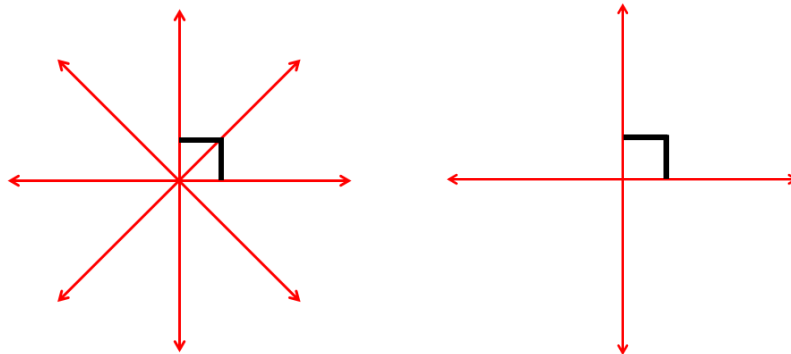

223. In fact, other wearable physiological sensing devices during this period provide further support for arranging 4 or 8 photodetectors as contemplated above such that the alignment axes are perpendicular. Aizawa, for example, explicitly teaches wearable pulse sensing devices that work with 8 and 4 detectors, as shown below. APPLE-1006, [0032].

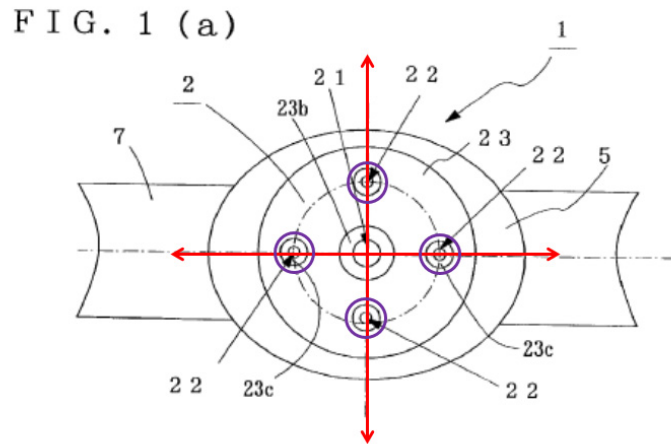
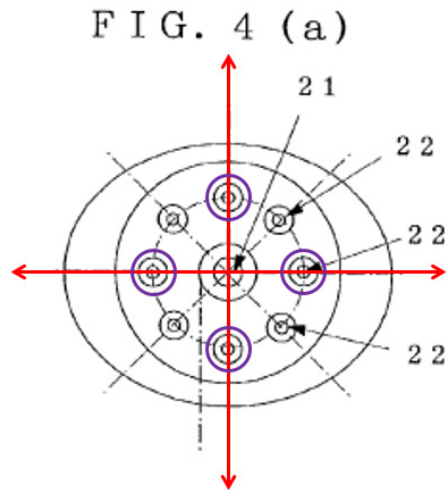

APPLE-1006, FIGS. 4(a) and 1(a)

224. Indeed, a POSITA would have considered using different numbers of spaced-apart detectors, namely 4 or 8, to be obvious and a routine and conventional design choice. APPLE-1006, [0032]. Relying on more or fewer detectors based on particular design requirements, as evidenced by Mendelson-1988 and Aizawa, was common practice well before the Critical Date, and there was nothing new or inventive about this aspect. *Id.*

### X. Claim 29

**[29] The noninvasive optical physiological measurement device of claim 27, wherein the first, second, third and fourth detectors form a cross pattern about the central axis.**

225. For reasons I discussed above in ¶ 209 with respect to element [21], herein incorporated by reference, this limitation is rendered obvious by the Mendelson-1988-Inokawa combination. APPLE-1015, FIG. 2(A).

### Y. Claim 30

**[30] The noninvasive optical physiological measurement device of claim 27, wherein the physiological parameter is at least one of: glucose, oxygen, oxygen saturation, methemoglobin, total hemoglobin, carboxyhemoglobin, or carbon monoxide.**

226. For reasons I discussed above in ¶ 206 with respect to element [18], herein incorporated by reference, this limitation is rendered obvious by the Mendelson-1988-Inokawa combination. APPLE-1015, 167, Abstract

#### **XIV. GROUND 2B – Claims 23-24 Are Rendered Obvious by Mendelson-1988 in view of Inokawa and Mendelson-2006.**

##### **A. Claim 23**

**[23] The noninvasive optical physiological measurement device of claim 1, wherein the noninvasive optical physiological measurement device is comprised as part of a mobile monitoring device.**

227. Mendelson-1988 teaches that data from its pulse oximeter is “acquired every 2 s (0.5 Hz) using an AT&T 6300 personal computer.” APPLE-1015, 171. A POSITA would have recognized that a personal computer, together with the pulse oximeter sensor attached to it, can serve as a mobile monitoring device, depending on the mobility of the particular PC involved. While Mendelson-1988 is silent regarding whether a mobile PC may be used, a POSITA would have sought to take advantage of parallel advances in mobile electronics to enable receiving information from the sensing device of Mendelson-1988 in a more convenient manner.

228. In this context, Mendelson-2006 (APPLE-1016), which I briefly described above in ¶¶ 69-71, teaches using a receiver module and a portable computer (*i.e.*, PDA) to communicate with a small, body-worn sensor that is highly similar to what is shown in Mendelson-1988. APPLE-1016, 913-914, FIGS. 1, 2. This is not surprising as both sensor modules of Mendelson-1988 and Mendelson-2006 are small devices that can be attached on the forehead and were developed by the same author. APPLE-1015, 167, FIG. 2; APPLE-1016, 912; FIG. 1. As described above in ¶¶ 145-149, the mobile PC of Mendelson-2006 may be connected either wirelessly or with a wire. APPLE-1016, 913, FIG. 1; APPLE-1029; APPLE-1022, 8.

229. Here, a POSITA would have been motivated to combine Mendelson-2006's receiver module and PDA with Mendelson-1988's detector to enable a more convenient and user-friendly interface with Mendelson-1988's detector and the ability to remotely monitor the user's physiological parameters. APPLE-1016, 914. A POSITA would have recognized, for instance, that using Mendelson-2006's receiver module and PDA with Mendelson-1988's sensor would have led to the predictable result of realizing a convenient mobile monitoring device without significantly altering or hindering the functions performed by Mendelson-1988. Indeed, a POSITA would have had a reasonable expectation of success in making this modification, and would have reasonably expected to reap benefits of a more

convenient interface and mobile monitoring capabilities as offered by Mendelson-2006.

230. To summarize, using the receiver module and PDA of Mendelson-2006 along with Mendelson-1988's sensor results in a mobile device that can be easily carried around by the user to provide convenient monitoring of the user's physiological parameters. APPLE-1015, 169; APPLE-1016, 913-914.

#### **B. Claim 24**

**[24] The noninvasive optical physiological measurement device of claim 1, wherein the mobile monitoring device includes a touch-screen display.**

231. Referring back to my discussion of element [23] in ¶¶ 227-230, which is incorporated herein, I explained how a POSITA would have looked to Mendelson-2006's PDA to enable more convenient, mobile monitoring of the user's physiological parameters. APPLE-1016, 913-914. Here, Mendelson-2006's PDA, reproduced below, provides "a low-cost touch screen interface," thus satisfying the touch-screen display limitation. APPLE-1016, 914.



APPLE-1016, FIG. 3.

**XV. GROUND 2C – Claim 25 Is Rendered Obvious by Mendelson-1988 in view of Inokawa, Mendelson-2006, and Beyer, Jr.**

**A. Claim 25**

**[25pre] A physiological monitoring system comprising**

232. The Mendelson-1988-Inokawa-Mendelson-2006 combination as described above in ¶¶ 227-230 results in a physiological monitoring system. In more detail, the Mendelson-1988-Inokawa-Mendelson-2006 combination provides a monitoring system that includes the sensor of Mendelson-1988 and the mobile PC of Mendelson-2006. APPLE-1015, Abstract, 167, 172; APPLE-1016, 913-914, FIG. 3.

**[25a] the noninvasive optical physiological measurement device of claim 1; and**

233. For reasons I discussed above in ¶¶ 165-181 with respect to elements [1pre]-[1d], herein incorporated by reference, this limitation is rendered obvious by the Mendelson-1988-Inokawa combination.

**[25b] a processor configured to receive the one or more signals and communicate physiological measurement information to a mobile phone.**

234. As I discussed in ¶¶ 227-230 for element [23], the combined system of Mendelson-1988-Inokawa-Mendelson-2006 can rely on the receiver module of Mendelson-2006 to receive signals from Mendelson-1988's sensor and then communicate this data to a PDA. APPLE-1016, 913-914. Additionally, as shown below, the receiver module of Mendelson-2006 includes PCB antenna for receiving data from the sensor and a microcontroller ( $\mu\text{C}$ ), or processor, for transmitting the received data to the PDA. *Id.*, 913.

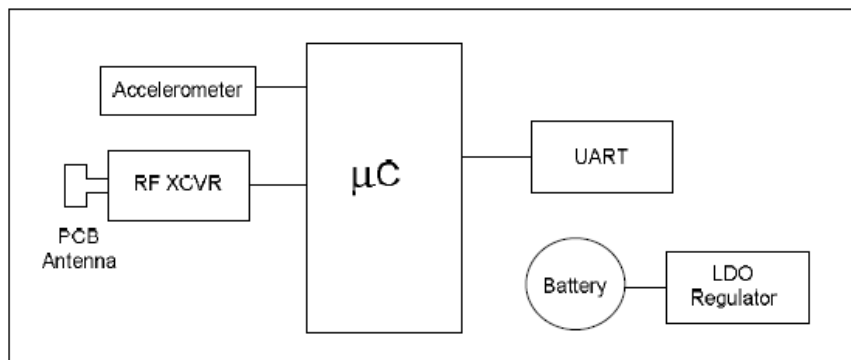

APPLE-1014, FIG. 2

235. Thus, the Mendelson-1988-Inokawa-Mendelson-2006 system includes a processor that is configured to receive physiological signals. *Id.*, 913-914, FIG. 2.

And while Mendelson-2006 teaches sending such signals (*i.e.*, physiological measurement information to a PDA, such as HP's iPAQ Pocket PC that is capable of various "wireless communication protocols," Mendelson-2006 does not disclose whether the PDA is a mobile phone. APPLE-1016, 914.

236. However, as I briefly described above in ¶ 72 with respect to Beyer, Jr., it was indeed well-known during this period that a PDA device as disclosed in Mendelson-2006 was often paired with cellular communication technology to provide a combined PDA/phone that is, essentially, a mobile phone. APPLE-1019, Abstract, 1:6-15; *see also* APPLE-1020, Abstract, FIG. 6, 7:55-63. Such a combined device would have allowed the user to enjoy the combined functionality of a phone and PDA in a single device, which would have been highly convenient since the user only needs to carry around a single device. Moreover, a POSITA would have recognized that "[i]t is often necessary to review the collected data, such as oxygen saturation, pulse rate and pulsatility value at a location remote to the patient being monitored." APPLE-2021, Abstract, FIG. 3. Thus, a POSITA would have looked to PDA devices with cellular connectivity in order to achieve more reliable and convenient patient monitoring. APPLE-1021, FIG. 3.

237. In more detail, Beyer, Jr. teaches "cellular PDA/GPS phones" that enable users "to rapidly call and communicate data among the users by touching display screen symbols and to enable the users to easily access data concerning other users



and other database information.” APPLE-1021, 1:6-15. As can be seen in the side-by-side comparison of Beyer, Jr.’s PDA and Mendelson-2006’s PDA below, the two devices are highly analogues in both form and function.

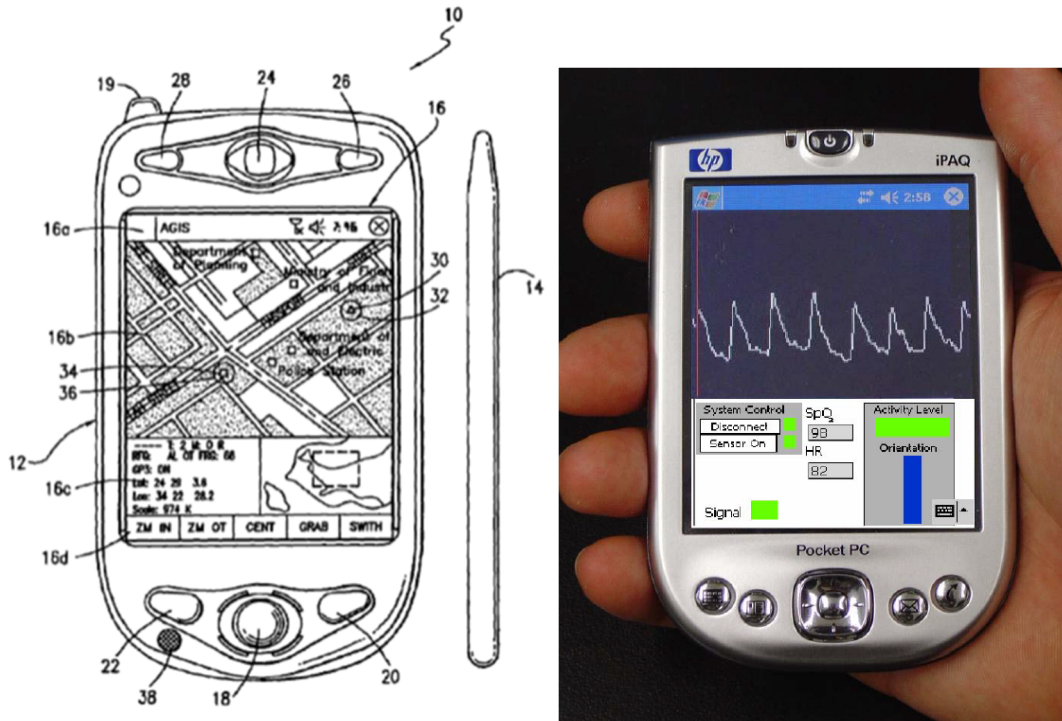

APPLE-1019, FIG. 1 (left); APPLE-1014, FIG. 3 (right)

238. In this context, a POSITA would have found it obvious to use a different PDA than the one mentioned in Mendelson-2006, and would have further found the same to be a routine and conventional design choice. Indeed, using a PDA that is also a mobile phone, as taught by Beyer, Jr. was common practice well before the '265 patent, and there was nothing new or inventive about changing one type of PDA for another.

## **XVI. CONCLUSION**

239. I reserve the right to supplement my opinions to address any information obtained, or positions taken, based on any new information introduced throughout this proceeding.

240. I declare under penalty of perjury that the foregoing is true and accurate to the best of my ability.