



US009079107B2

(12) **United States Patent**
Oono

(10) **Patent No.:** **US 9,079,107 B2**

(45) **Date of Patent:** **Jul. 14, 2015**

(54) **GAME CONTROL METHOD, GAME CONTROL DEVICE, AND RECORDING MEDIUM**

(71) Applicant: **GREE, Inc.**, Minato-ku, Tokyo (JP)

(72) Inventor: **Kazuki Oono**, Minato-ku (JP)

(*) Notice: Subject to any disclaimer, the term of this patent is extended or adjusted under 35 U.S.C. 154(b) by 0 days.

(21) Appl. No.: **14/198,411**

(22) Filed: **Mar 5, 2014**

(65) **Prior Publication Data**

US 2014/0274401 A1 Sep. 18, 2014

(30) **Foreign Application Priority Data**

Mar. 12, 2013 (JP) 2013-049388
Sep. 27, 2013 (JP) 2013-202682
Dec. 19, 2013 (JP) 2013-262855

(51) **Int. Cl.**
A63F 9/24 (2006.01)
A63F 13/58 (2014.01)
A63F 13/795 (2014.01)
A63F 13/822 (2014.01)

(52) **U.S. Cl.**
CPC *A63F 13/58* (2014.09); *A63F 13/795* (2014.09); *A63F 13/822* (2014.09)

(58) **Field of Classification Search**
CPC A63F 9/24
USPC 463/42
See application file for complete search history.

(56) **References Cited**

U.S. PATENT DOCUMENTS

2011/0124415 A1* 5/2011 Shimono 463/42

FOREIGN PATENT DOCUMENTS

JP 11-244533 9/1999
JP 2011-110139 6/2011

OTHER PUBLICATIONS

Verified English Translation of Notice of Reasons for Rejection for corresponding JP 2013-049388, mailed May 21, 2013, 5pp.

(Continued)

Primary Examiner — Omkar Deodhar

(74) *Attorney, Agent, or Firm* — Christie, Parker & Hale, LLP

(57) **ABSTRACT**

Provided is a game control method carried out by a game control device connected to communication terminals used by users who play a game. The device has a storage unit for storing group information indicative of a group consisting of users and game piece information indicative of game pieces constituting one item. The method includes giving a game piece to each user in accordance with a user operation to his/her communication terminal; storing obtained game piece information indicative of the game piece given to each user in the storage unit; determining whether all of the game pieces necessary to constitute the one item indicated by the game piece information are given to users constituting a group indicated by the group information based on the obtained game piece information; and giving a reward to users constituting the group if it is determined that all of the game pieces are given.

11 Claims, 12 Drawing Sheets

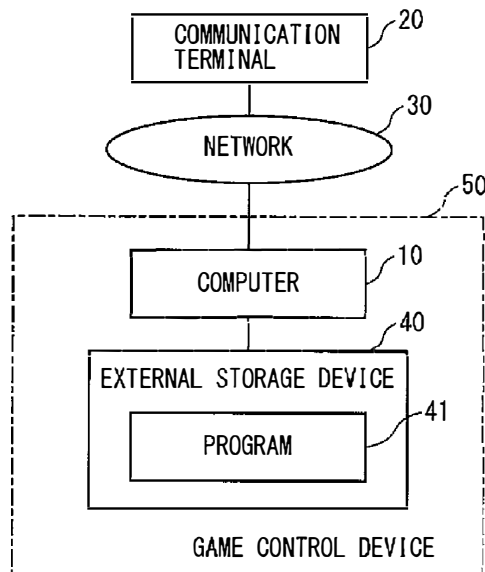

US 9,079,107 B2

Page 2

(56)

References Cited

OTHER PUBLICATIONS

Dai-Ranto!! Guild Battle G, Famitsu mobage, Vol. 2, Enterbrain Inc., Jul. 21, 2011, Weekly Famitsu Aug. 25 extra edition, p. 62-63 (5pp.) (Refer to Notice of Reasons for Rejection mailed on May 21, 2013, regarding priority Japanese application No. 2013-049388 for relevance).

Chevalier Saga Tactics, [online], OnlineGamer iXLL Inc., posted on Aug. 17, 2012, searched on May 14, 2013, Internet <URL <http://www.onlinegamer.jp/news/201208170038/>>, 4pp. (Refer to Notice of Reasons for Rejection mailed on May 21, 2013, regarding priority Japanese application No. 2013-049388 for relevance).

* cited by examiner

FIG. 1

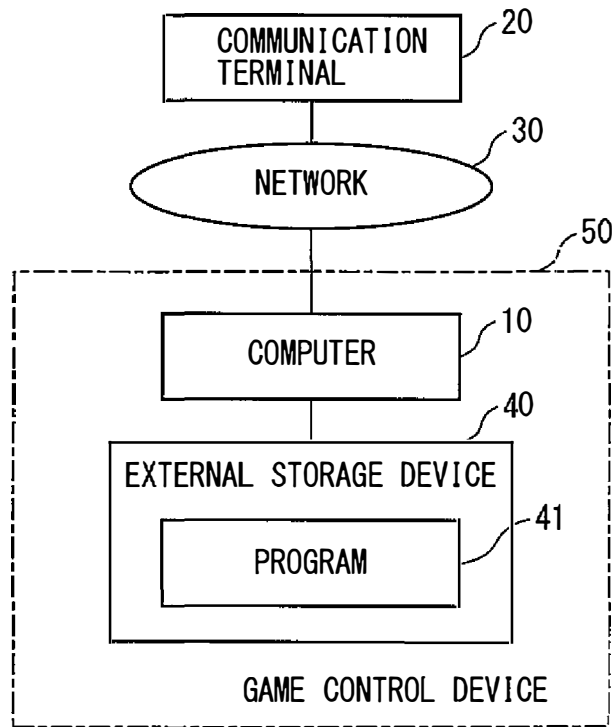

FIG. 2

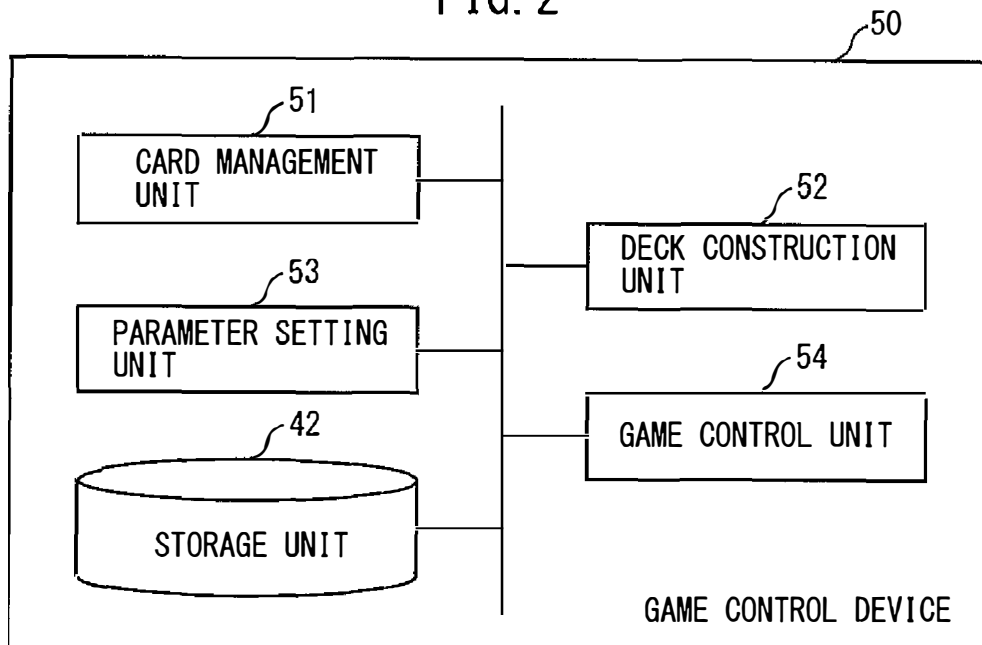

FIG. 3

CARD ID	HP	ATTACK POWER	SPEED	SKILL
CARD 1	100	10	12	SKILL 1
CARD 2	120	15	8	SKILL 2
⋮	⋮	⋮	⋮	⋮

FIG. 4

ROBOT ID	HP	ATTACK POWER	SPEED	ATTRIBUTE
ROBOT 1	300	30	40	INTERMEDIATE
ROBOT 2	290	25	50	LONG
ROBOT 3	320	35	30	SHORT

FIG. 5

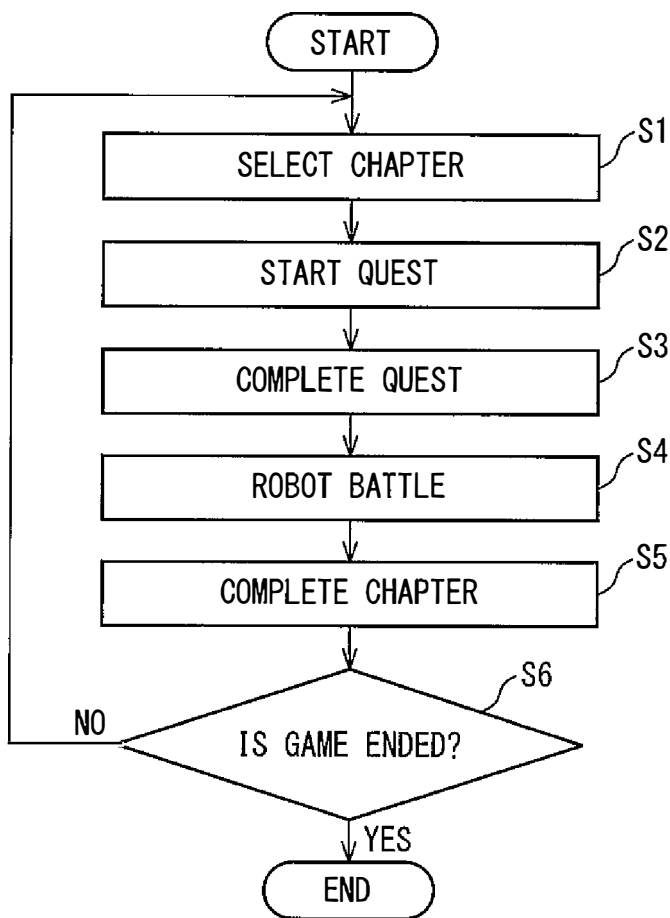
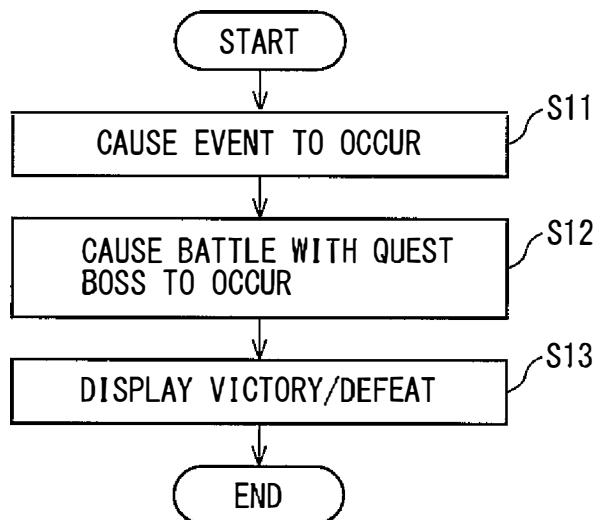

FIG. 6



Explore Litigation Insights

Docket Alarm provides insights to develop a more informed litigation strategy and the peace of mind of knowing you're on top of things.

Real-Time Litigation Alerts



Keep your litigation team up-to-date with **real-time alerts** and advanced team management tools built for the enterprise, all while greatly reducing PACER spend.

Our comprehensive service means we can handle Federal, State, and Administrative courts across the country.

Advanced Docket Research



With over 230 million records, Docket Alarm's cloud-native docket research platform finds what other services can't. Coverage includes Federal, State, plus PTAB, TTAB, ITC and NLRB decisions, all in one place.

Identify arguments that have been successful in the past with full text, pinpoint searching. Link to case law cited within any court document via Fastcase.

Analytics At Your Fingertips



Learn what happened the last time a particular judge, opposing counsel or company faced cases similar to yours.

Advanced out-of-the-box PTAB and TTAB analytics are always at your fingertips.

API

Docket Alarm offers a powerful API (application programming interface) to developers that want to integrate case filings into their apps.

LAW FIRMS

Build custom dashboards for your attorneys and clients with live data direct from the court.

Automate many repetitive legal tasks like conflict checks, document management, and marketing.

FINANCIAL INSTITUTIONS

Litigation and bankruptcy checks for companies and debtors.

E-DISCOVERY AND LEGAL VENDORS

Sync your system to PACER to automate legal marketing.