



US 20130190094A1

(19) **United States**

(12) **Patent Application Publication**
Ronen et al.

(10) **Pub. No.: US 2013/0190094 A1**

(43) **Pub. Date: Jul. 25, 2013**

(54) **ASYNCHRONOUS TEAM-BASED GAME**

(52) **U.S. Cl.**
USPC **463/42**

(76) Inventors: **Eyal Ronen**, Ramat Hasharon (IL);
Doron Nir, Tel Aviv (IL)

(57) **ABSTRACT**

(21) Appl. No.: **13/353,779**

An asynchronous, multiplayer gaming platform is disclosed which provides for a collaborative team effort on a shared canvas. Shared elements (e.g., a shared canvas, shared object or a shared inventory) of a game are stored on a computer readable storage medium that is accessible to the players of the team over the network. Data is received from a first player of the team which is indicative of gaming activities modifying the shared elements. The shared elements are updated with the data received from the first player to generate an updated game state. Update data representing the updated game state is transmitted to at least one other player on the team.

(22) Filed: **Jan. 19, 2012**

Publication Classification

(51) **Int. Cl.**
A63F 9/24 (2006.01)

100

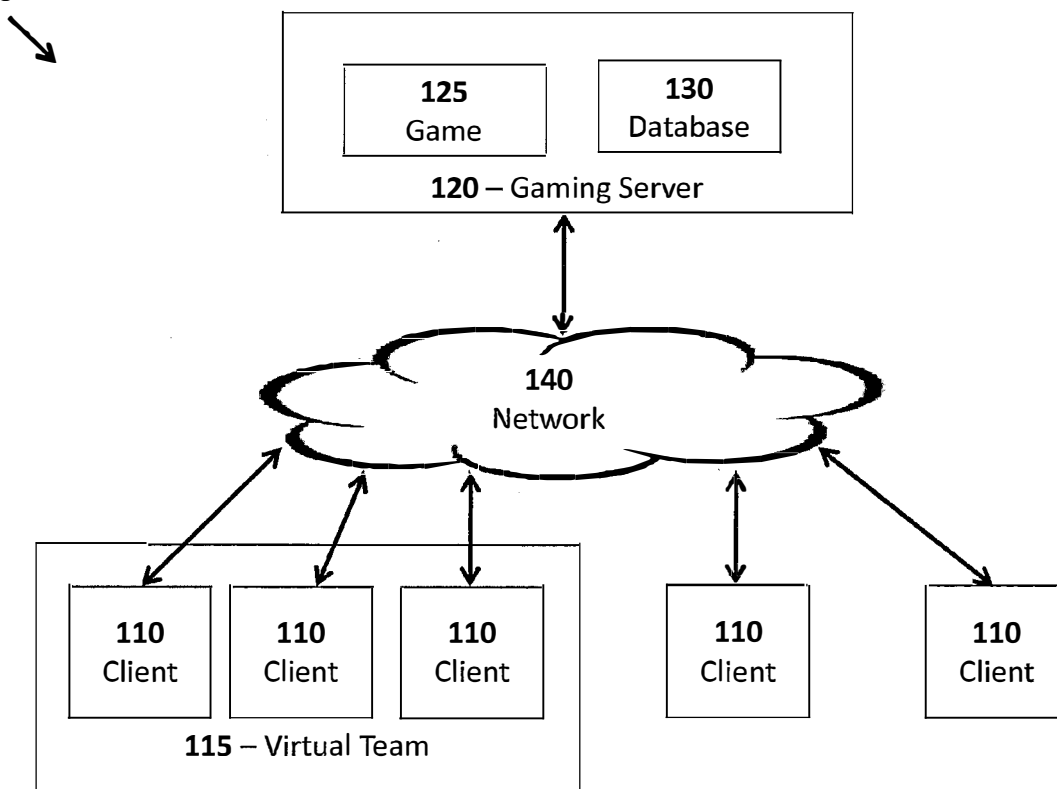

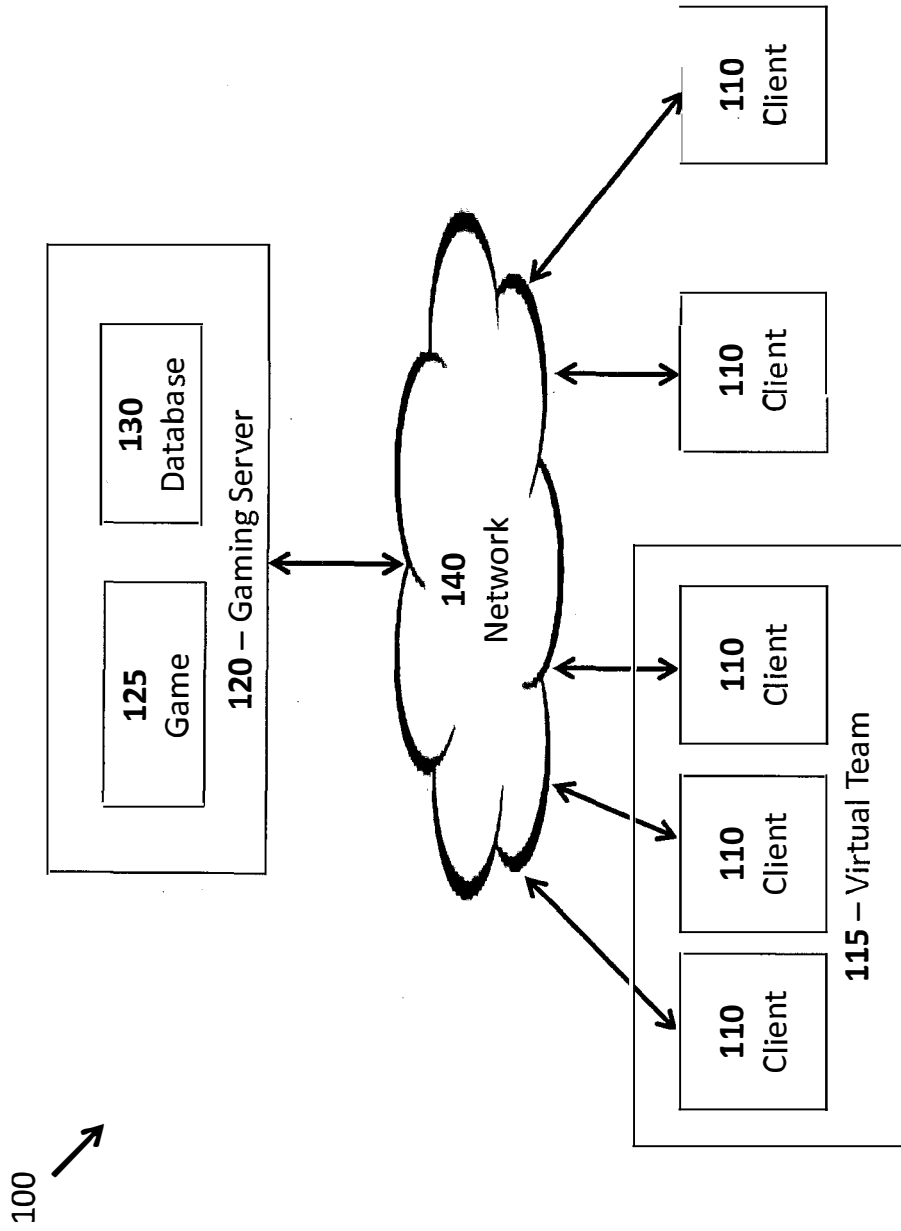

Figure 1

200 ↗

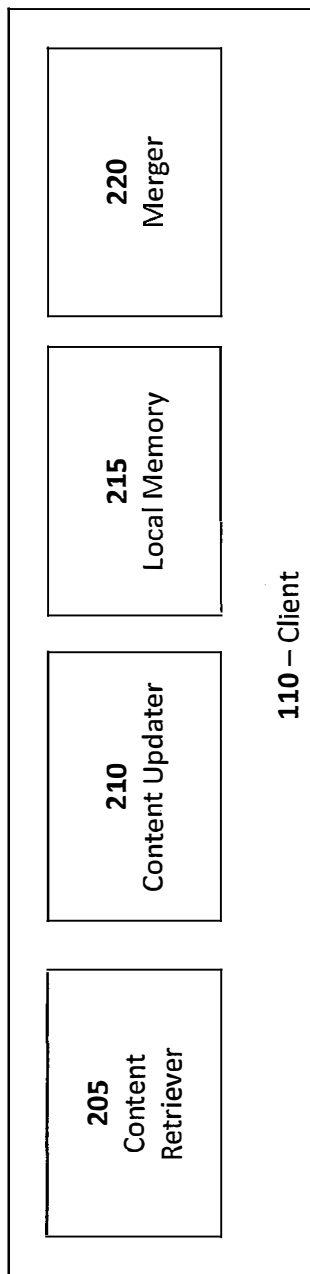
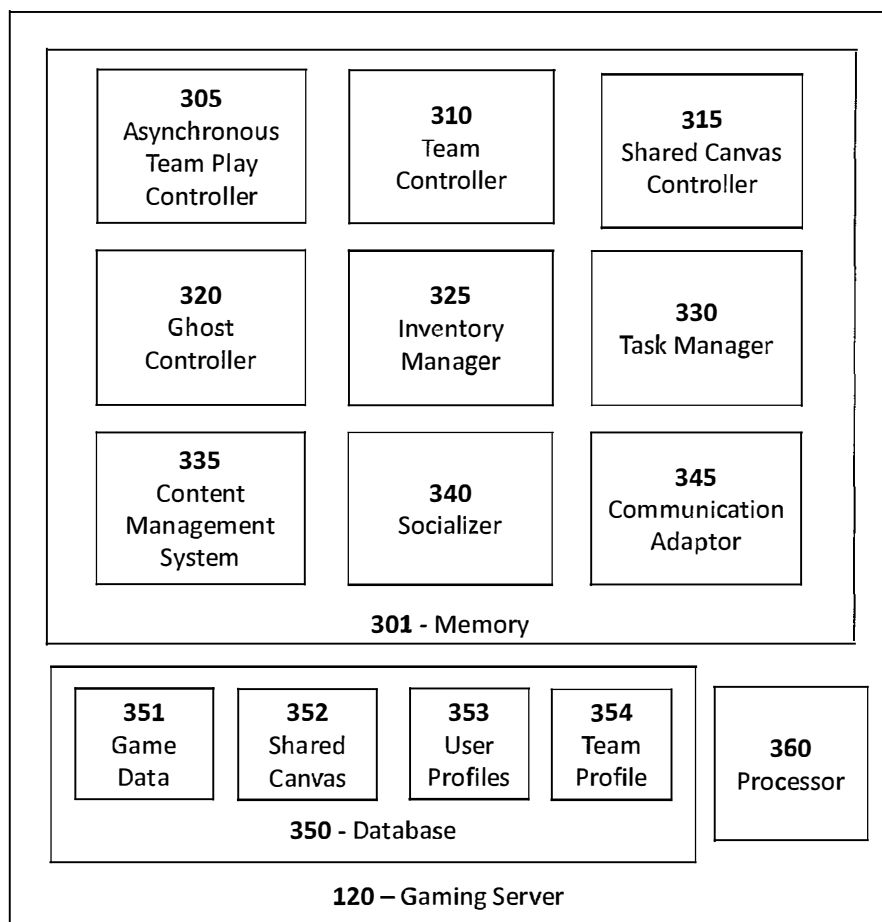

Figure 2

300
↙

Figure 3



400

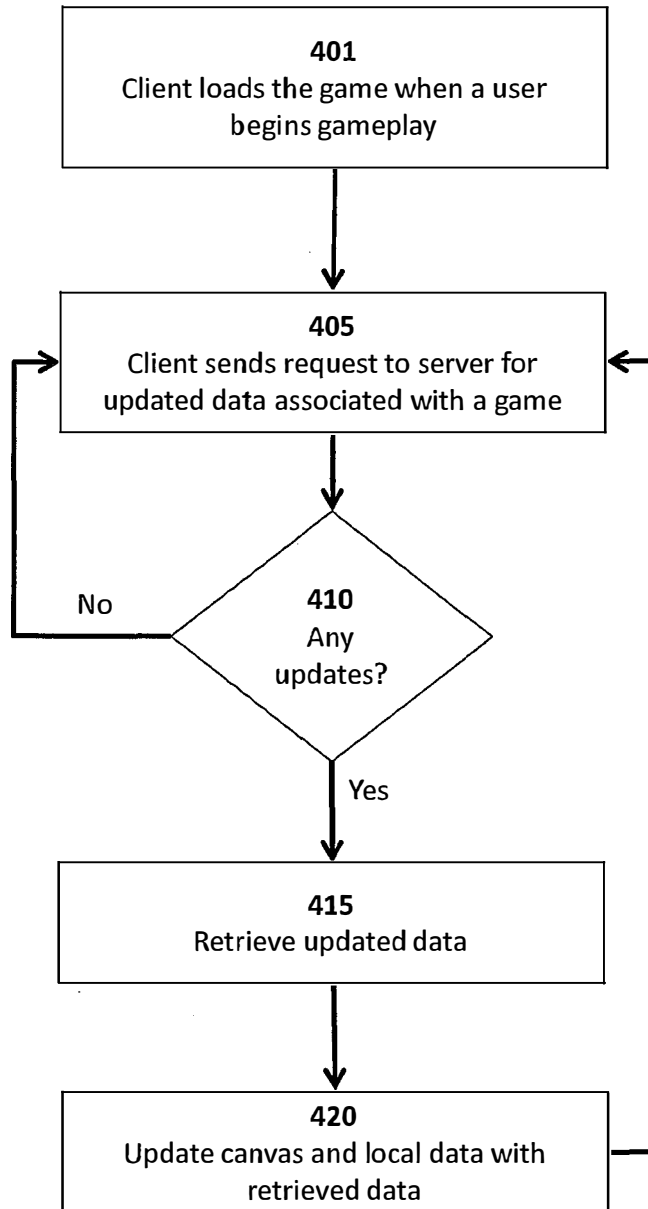

Figure 4

Explore Litigation Insights

Docket Alarm provides insights to develop a more informed litigation strategy and the peace of mind of knowing you're on top of things.

Real-Time Litigation Alerts



Keep your litigation team up-to-date with **real-time alerts** and advanced team management tools built for the enterprise, all while greatly reducing PACER spend.

Our comprehensive service means we can handle Federal, State, and Administrative courts across the country.

Advanced Docket Research



With over 230 million records, Docket Alarm's cloud-native docket research platform finds what other services can't. Coverage includes Federal, State, plus PTAB, TTAB, ITC and NLRB decisions, all in one place.

Identify arguments that have been successful in the past with full text, pinpoint searching. Link to case law cited within any court document via Fastcase.

Analytics At Your Fingertips



Learn what happened the last time a particular judge, opposing counsel or company faced cases similar to yours.

Advanced out-of-the-box PTAB and TTAB analytics are always at your fingertips.

API

Docket Alarm offers a powerful API (application programming interface) to developers that want to integrate case filings into their apps.

LAW FIRMS

Build custom dashboards for your attorneys and clients with live data direct from the court.

Automate many repetitive legal tasks like conflict checks, document management, and marketing.

FINANCIAL INSTITUTIONS

Litigation and bankruptcy checks for companies and debtors.

E-DISCOVERY AND LEGAL VENDORS

Sync your system to PACER to automate legal marketing.