

UNITED STATES PATENT AND TRADEMARK OFFICE

BEFORE THE PATENT TRIAL AND APPEAL BOARD

SZ DJI TECHNOLOGY CO., LTD.,
Petitioner,

v.

AUTEL ROBOTICS USA LLC,
Patent Owner.

Case PGR2019-00016
Patent 10,044,013 B2

Before ERICA A. FRANKLIN, JENNIFER MEYER CHAGNON, and
AVELYN M. ROSS, *Administrative Patent Judges*.

FRANKLIN, *Administrative Patent Judge*.

DECISION
Institution of Post-Grant Review
35 U.S.C. § 324(a)

I. INTRODUCTION

SZ DJI Technology Co. LTD. (“Petitioner”), filed a Petition to institute a post-grant review of claims 1–24 of U.S. Patent No. 10,044,013 B2 (Ex. 1001, “the ’013 patent”). Paper 6 (Corrected Petition, “Pet.”). Autel Robotics USA LLC (“Patent Owner”) did not to file a Preliminary Response to the Petition.

We have authority to determine whether to institute a post-grant review under 35 U.S.C. § 324, which provides that a post-grant review may not be instituted unless the information presented in the petition, if unrebutted, “would demonstrate that it is more likely than not that at least 1 of the claims challenged in the petition is unpatentable.” 35 U.S.C. § 324(a). Upon considering the Petition, we determine that Petitioner has demonstrated that it is more likely than not that at least one of the claims challenged in the Petition is unpatentable. Accordingly, we institute a post-grant review of all challenged claims based upon all grounds raised in the Petition.

A. *Related Proceedings*

The parties provide notice of the following related matter: *Certain Unmanned Aerial Vehicles and Components Thereof*, 337-TA-1133 (ITC). Pet. 2; Paper 5, 2. Petitioner also notes the following related district court proceeding: “*SZ DJI Technology Co. Ltd., et al. v. Autel Robotics USA LLC, et al.*, DED-1-16-cv-00706.” Pet. 2. The parties note also that an application related to the ’013 patent, U.S. Patent Application 15/598,914, is pending before the Office. Pet. 2, Paper 5, 2.

B. The '013 Patent

The '013 patent is eligible for post-grant review. Post-grant review is available only for patents “described in section 3(n)(1)” of the Leahy-Smith America Invents Act (“AIA”), Pub L. No. 112-29, 125 Stat. 284 (2011). AIA § 6(f)(2)(A).¹ Those are patents that issue from applications “that contain[] or contained at any time . . . a claim to a claimed invention that has an effective filing date in section 100(i) of title 35, United States Code, that is on or after” “the expiration of the 18-month period beginning on the date of the enactment of” the AIA. *See* AIA § 3(n)(1). The AIA was enacted on September 16, 2011, therefore, post-grant review is available only for patents that, at one point, contained at least one claim with an effective filing date, as defined by 35 U.S.C. § 100(i), on or after March 16, 2013. The earliest possible filing date for the '013 patent is December 14, 2015, which falls after the March 16, 2013 date. *See* Ex. 1001; *see also* Pet. 3 (noting “earliest possible priority date of the '013 patent (December 14, 2015)”).

The '013 patent describes an unmanned aerial vehicle and, particularly, a battery used for the vehicle. Ex. 1001, 1:18–20. The Specification explains that “[i]n prior arts, a main body of the unmanned vehicle offers a cavity for accommodating the power of the unmanned aerial vehicle, such as a lithium battery.” *Id.* at 1:39–41. A sealing board set in an opening of the cavity of the unmanned vehicle would be employed to fasten

¹ The AIA also requires the petition to be filed within nine months of the issue date of the challenged patent. 35 U.S.C. § 321(c). The '013 patent issued on August 7, 2018. Ex. 1001. The Petition has been accorded a filing date of November 12, 2018, Paper 3, which is within the nine-month window. Thus, Petitioner has timely filed the Petition.

the battery, thereby preventing it from dropping from the cavity during flight. *Id.* at 1:42–44. “The sealing board is usually fixed to the main body of the unmanned aerial vehicle by screws, bolts or other fasteners.” *Id.* at 1:45–46. Those screws, bolts, or fasteners would need to be loosened before changing the battery, and then tightened after changing the battery, thus making it inconvenient to change a battery. *Id.* at 1:47–50.

The Specification explains that the present invention seeks to overcome defects that cause the inconvenience in changing the battery. *Id.* at 1:54–57. In particular, the Specification states that “because a clamp button is configured on one end of the shell, the battery is capable of detachably connecting with the main body of the unmanned aerial vehicle which makes the changing of the battery [] more convenient.” *Id.* at 2:47–50. Additionally, “the inner side of the clamp button is configured with a restorable elastic piece for realizing the clamp button returning back to [its] original place automatically.” *Id.* at 2:51–54.

Figure 1 of the '013 patent is reproduced below:

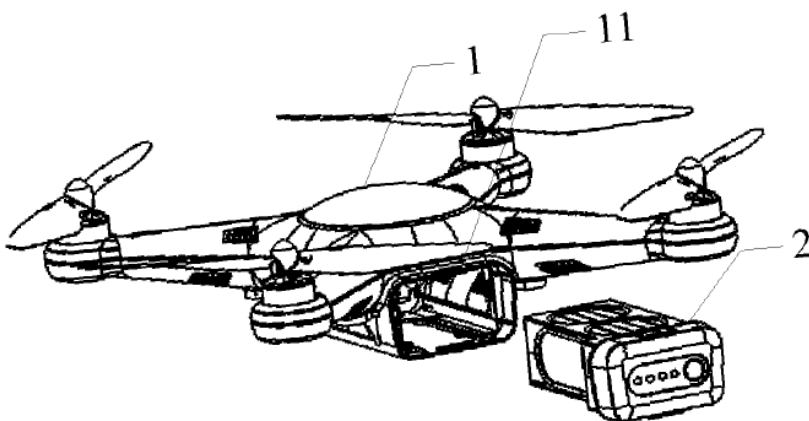

Fig.1

Figure 1 depicts a disassembled structure diagram of an unmanned aerial vehicle (“UAV”) in an embodiment of the invention. *Id.* at 2:65–67. The vehicle includes a UAV main body 1 and a UAV battery 2, shown removed and away from the UAV opening of the battery compartment 11. *Id.* at 3:40–42; 4:60–61.

Figure 2 of the '013 patent is reproduced below:

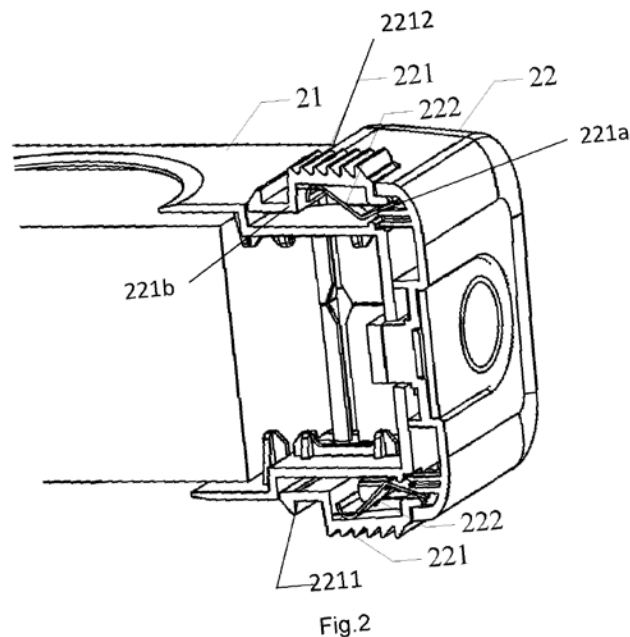

Figure 2 depicts a structure diagram of a battery used for a UAV in an embodiment of the invention. *Id.* at 3:1–3. The battery includes a battery body 21 and a shell 22 disposed on one end of the battery body. *Id.* at 3:47–50. A clamp button 221 is configured on a side of the shell, opposite the UAV. *Id.* at 3:50–51. One end 221a of the clamp button is fixed to the shell, and the other end 221b of the clamp button is used to detachably connect the UAV. *Id.* at 3:51–54. End 221b of the clamp button has a hook 2211 for detachably hanging on the UAV. *Id.* at 3:55–58. An anti-slip structure 2212 is configured on the outer surface of the clamp button to

Explore Litigation Insights

Docket Alarm provides insights to develop a more informed litigation strategy and the peace of mind of knowing you're on top of things.

Real-Time Litigation Alerts



Keep your litigation team up-to-date with **real-time alerts** and advanced team management tools built for the enterprise, all while greatly reducing PACER spend.

Our comprehensive service means we can handle Federal, State, and Administrative courts across the country.

Advanced Docket Research



With over 230 million records, Docket Alarm's cloud-native docket research platform finds what other services can't. Coverage includes Federal, State, plus PTAB, TTAB, ITC and NLRB decisions, all in one place.

Identify arguments that have been successful in the past with full text, pinpoint searching. Link to case law cited within any court document via Fastcase.

Analytics At Your Fingertips



Learn what happened the last time a particular judge, opposing counsel or company faced cases similar to yours.

Advanced out-of-the-box PTAB and TTAB analytics are always at your fingertips.

API

Docket Alarm offers a powerful API (application programming interface) to developers that want to integrate case filings into their apps.

LAW FIRMS

Build custom dashboards for your attorneys and clients with live data direct from the court.

Automate many repetitive legal tasks like conflict checks, document management, and marketing.

FINANCIAL INSTITUTIONS

Litigation and bankruptcy checks for companies and debtors.

E-DISCOVERY AND LEGAL VENDORS

Sync your system to PACER to automate legal marketing.