

[54] ELECTRICAL FUSE

[75] Inventor: Seibang Oh, Elk Grove Village, Ill.

[73] Assignee: Littelfuse, Inc., Des Plaines, Ill.

[21] Appl. No.: 868,421

[22] Filed: Jun. 3, 1986

[51] Int. Cl.<sup>4</sup> ..... H01H 85/24; H01H 85/16

[52] U.S. Cl. .... 337/264; 337/264;  
337/255

[58] Field of Search ..... 337/255, 256, 257, 258,  
337/260, 261, 262, 263, 264, 295

[56] References Cited

U.S. PATENT DOCUMENTS

4,394,638	7/1983	Sian	337/264
4,544,907	10/1985	Takano	337/264
4,604,602	8/1986	Borzoni	337/264

Primary Examiner—Harold Broome

Attorney, Agent, or Firm—Russell E. Hattis; Stephen R. Arnold

[57] ABSTRACT

An automotive blade-type fuse has an enlarged transparent extraction flange. The flange is configured as a thin-wall structure having a cavity therein running substantially its entire length. The fuse terminal blades are captively secured in a housing to extend from the bottom thereof and have narrow extensions at the outer edges of the blades which extend upwardly into the flange cavity. A fuse link extends between the blade extensions within the cavity and at a stand-off distance from the interior walls of the cavity. The fuse housing is preferably of identical half-shell construction having lengthwise-running centering ribs and associated mating recesses to facilitate assembly.

21 Claims, 12 Drawing Figures

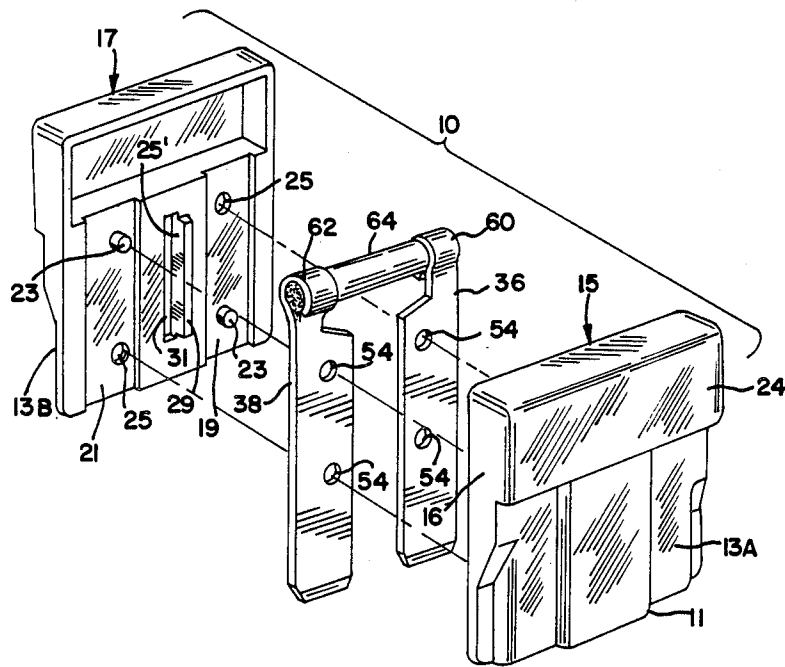

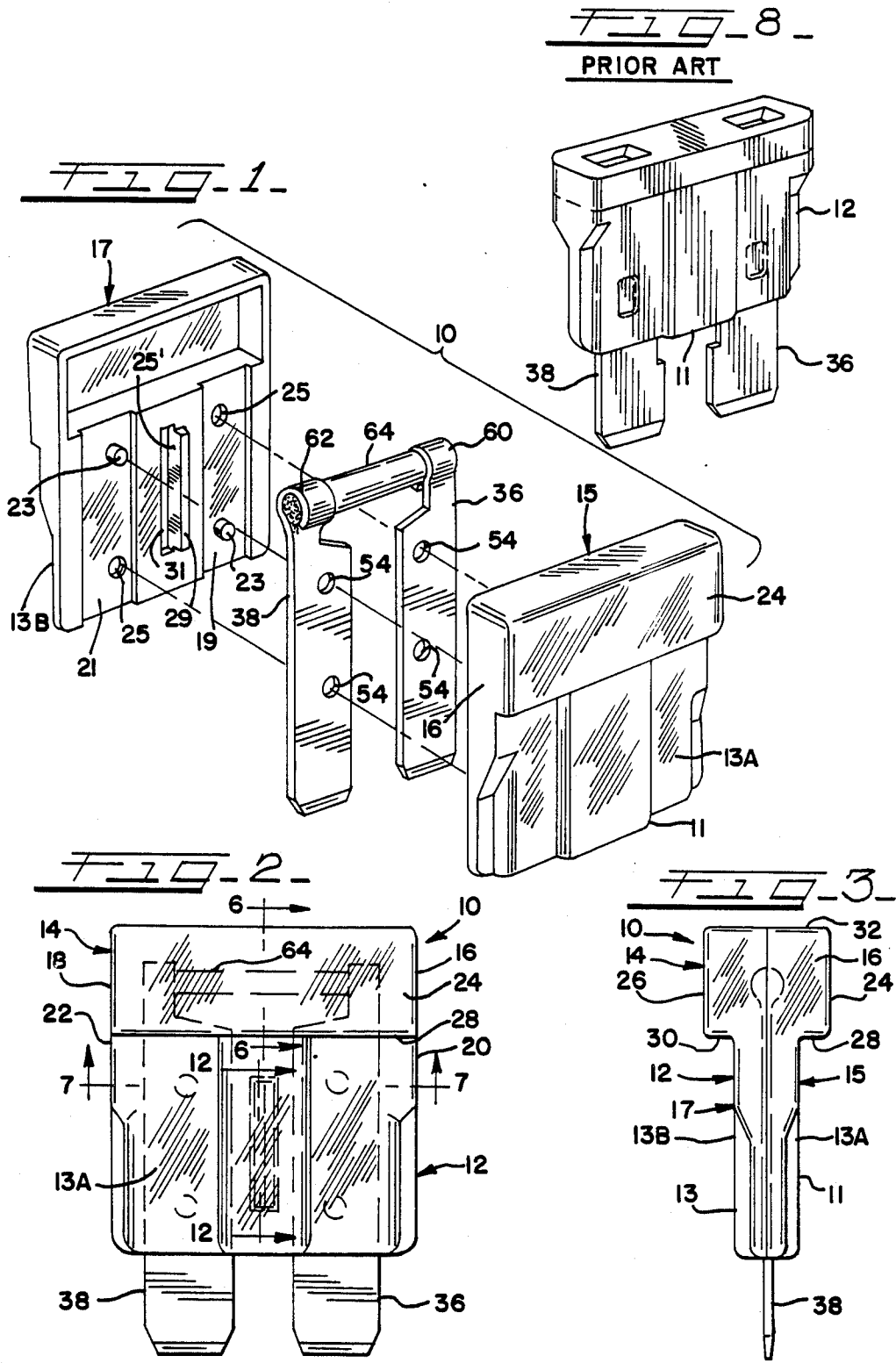



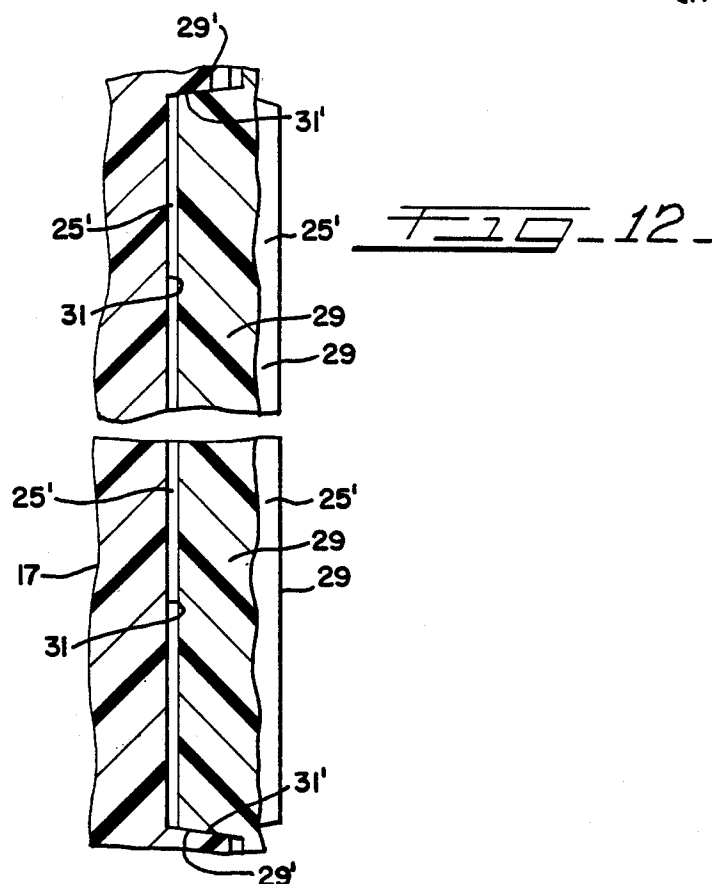
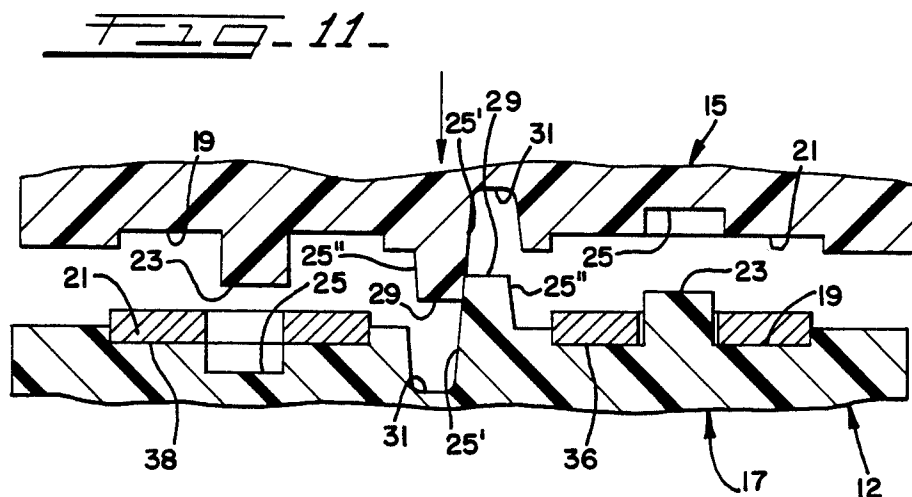

## ELECTRICAL FUSE

## DESCRIPTION

## 1. TECHNICAL FIELD OF THE INVENTION

The technical field of the invention is the electrical circuit breaker art, and in particular, automotive electrical fuses, although some aspects thereof have a broader application.

## 2. BACKGROUND OF THE INVENTION

Along with the increasing complexity and number of electrical circuits employed in automotive installations, there has grown an increasing demand for miniature fuses to protect these installations. Because of the number of these fuses and the restricted available space to accommodate them, miniaturization of the fuses and their common fuse holder block has been a prime objective.

In particular, the currently favored automotive blade-type fuses are miniature fuses having a generally narrow housing body, from the bottom of which extend two coplanar parallel terminal blades. These fuses must meet certain standard test regulations of the Society of Automotive Engineers (SAE) and original equipment manufacturers (OEM) who specify the test conditions involved. The fuses must blow within certain minimum and maximum time limits under various test conditions. Thus, if a fuse blows in less than a given minimum time limit for the test condition involved, it is prone to premature blowing and fails the test. It was discovered that even though these fuses have passed the various SAE tests, some prematurely blowing sometimes occurs under peculiar load conditions found in some automobiles not specified so far in the test conditions. To avoid this premature blowing problem under these peculiar test conditions, the present unique "slow blow" fuse design was developed.

The blowing time of a fuse is in part governed by its mass. The larger the mass for a given resistance, the longer its blowing time will be. The resistance of a fuse link increases with its length and decreases with the cross-sectional area. Thus, a fuse link of a given resistance has its maximum mass when the fuse link has a maximum length and thickness. Despite the fact that fuse engineers had knowledge of this fact, blade fuse designers have not designed their fuses to provide a desired maximum delay to minimize premature blowing problems which can arise under the peculiar load conditions referred to.

In addition to accommodating a relatively massive fuse link, it is desired that fuse links should preferably be rigidly encased in an insulating housing which is sufficiently rugged that there is negligible likelihood that upon fuse withdrawal a blade tears loose and remains in the fuse block. Removal of a broken blade under such conditions can be extremely tedious. Finally, it is desirable that the fuse link itself be visible while the fuse is still in place in the fuse holder block, so that a blown fuse may be detected by rapid visual inspection of the entire aggregate of fuses.

Two prior art patents exemplify bladetype fuses suitable for automotive use embodying some, but not all of the abovementioned characteristics. Thus, U.S. Pat. No. 3,909,767 issued to Williamson, et al. on Sept. 30, 1975, illustrates the present commercially used automotive blade fuse. The structure will be discussed in further detail in the Description of Invention. The fuse design shown in this patent is still the most preferred

fuse design for most automotive circuits. In this type of structure, all metallic portions of the fuse are preferably formed as a single piece. This piece, except for exposed end portions of the terminal blades, is enclosed by an insulating fuse housing body preferably having a head portion provided with downwardly facing gripping shoulders to facilitate removal of the fuse from a fuse block. These shoulders have been provided by a flanged head. The fuse link extending between the terminal blades has generally been centrally disposed in the portion of the housing body below the flange portion thereof. The housing body is initially cold staked into staking apertures in the terminal blades and then the staked areas are ultrasonically welded, so that the staked portions of the housing more securely anchor the metal and housing portions together.

The SAE specifications also include dimensional specifications which give the outer limitations of the dimensions of the fuse housing and terminal blades, so that automobile manufacturers can manufacture fuse holder blocks with fuse-receiving cavities which can accommodate the fuses. Therefore, while it may have been desirable to design the automobile fuses described with more massive fuse links to decrease the chances of premature blowing of the fuses, fuse designers could not increase the mass of the fuse to the desired ideal extent because of the space limitations in the fuse housing. The problem of fuse link size is particularly a problem in high current rated fuses where the fuse link requires a larger mass and must dissipate more heat than a lower current rated fuse. It is also more important in hotter higher current rated fuses to provide a significant space between the fuse link and the adjacent housing between walls to avoid damage to the housing. The space limitations in the housing of the prior fuse design did not provide the space necessary for a fuse link of the desired mass (i.e., the desired length and cross-sectional area) to overcome premature blowing problems and provide adequate spacing of the fuse link from the housing walls under the peculiar conditions referred to above.

Another automotive blade fuse which was manufactured at one time and did not meet the electrical or dimensional SAE specifications is shown in U.S. Pat. No. 4,164,726 issued to Weibe on Aug. 14, 1979. In the fuse therein disclosed, the upper ends of the fuse blades extend with their full widths up into the head portion of the housing and the fuse link is attached thereto to extend between the still closely spaced confronting margins of the blade extensions. The effective electrical length and mass of the fuse link is determined by the close inter-blade spacing at the joint where the fuse link connects thereto and so this fuse link did not have the desired mass to avoid the premature blowing problem referred to. Moreover, this fuse link was physically embedded in the plastic of the fuse housing by injection molding and did not have the desired standoff distance between the fuse and the housing material. On the other hand, the housing was made transparent, so that a blown fuse element was readily visible in the head portion of the fuse.

Both of the foregoing fuses are illustrated in the accompanying drawings, and will be further discussed in the Description of the Invention.

## SUMMARY OF INVENTION

The most preferred form of the invention is an automotive fuse provided with a pair of terminal blades

# Explore Litigation Insights

Docket Alarm provides insights to develop a more informed litigation strategy and the peace of mind of knowing you're on top of things.

## Real-Time Litigation Alerts



Keep your litigation team up-to-date with **real-time alerts** and advanced team management tools built for the enterprise, all while greatly reducing PACER spend.

Our comprehensive service means we can handle Federal, State, and Administrative courts across the country.

## Advanced Docket Research



With over 230 million records, Docket Alarm's cloud-native docket research platform finds what other services can't. Coverage includes Federal, State, plus PTAB, TTAB, ITC and NLRB decisions, all in one place.

Identify arguments that have been successful in the past with full text, pinpoint searching. Link to case law cited within any court document via Fastcase.

## Analytics At Your Fingertips



Learn what happened the last time a particular judge, opposing counsel or company faced cases similar to yours.

Advanced out-of-the-box PTAB and TTAB analytics are always at your fingertips.

## API

Docket Alarm offers a powerful API (application programming interface) to developers that want to integrate case filings into their apps.

## LAW FIRMS

Build custom dashboards for your attorneys and clients with live data direct from the court.

Automate many repetitive legal tasks like conflict checks, document management, and marketing.

## FINANCIAL INSTITUTIONS

Litigation and bankruptcy checks for companies and debtors.

## E-DISCOVERY AND LEGAL VENDORS

Sync your system to PACER to automate legal marketing.