

UNITED STATES PATENT AND TRADEMARK OFFICE

BEFORE THE PATENT TRIAL AND APPEAL BOARD

APPLE INC.,
Petitioner,

v.

UNILOC 2017 LLC,
Patent Owner.

Case IPR2019-00702
Patent 7,969,925 B2

Before SALLY C. MEDLEY, JEFFREY S. SMITH, and GARTH D. BAER,
Administrative Patent Judges.

MEDLEY, *Administrative Patent Judge.*

DECISION
Granting Institution of *Inter Partes* Review
35 U.S.C. § 314

I. INTRODUCTION

Apple Inc. (“Petitioner”) filed a Petition for *inter partes* review of claims 1–20 of U.S. Patent No. 7,969,925 B2 (Ex. 1001, “the ’925 patent”). Paper 1 (“Pet.”). Uniloc 2017 LLC (“Patent Owner”) filed a Preliminary Response. Paper 6 (“Prelim. Resp.”). Institution of an *inter partes* review is authorized by statute when “the information presented in the petition . . . and any response . . . shows that there is a reasonable likelihood that the petitioner would prevail with respect to at least 1 of the claims challenged in the petition.” 35 U.S.C. § 314(a). Upon consideration of the Petition and Preliminary Response, we conclude the information presented shows that there is a reasonable likelihood that Petitioner would prevail in establishing the unpatentability of at least one of claims 1–20 of the ’925 patent.

A. Related Matters

Petitioner and Patent Owner indicate that the ’925 patent is the subject of the following currently pending court proceedings: *Uniloc USA, Inc., et al. v. Apple Inc.*, Case No. 1:18-cv-00166-LY (W.D. Tex.); and *Uniloc USA, Inc. et al. v. Apple Inc.*, Case No. 4-19-cv-01696 (N.D. Cal.). Pet. 1–2; Prelim. Resp. 6.

B. The ’925 Patent

The specification of the ’925 patent describes “a method for establishing a direct data transfer session between mobile devices over a digital mobile network system that supports data packet-based communications.” Ex. 1001, 1:61–64. According to the ’925 patent, a separate data server is not required to provide a known location from which a recipient retrieves data. *Id.* at 1:64–67. Rather, “a mobile device initiating a data transfer opens a listening port defined by an underlying data packet

based network protocol.” *Id.* at 1:67–2:2. Initiating mobile device sends an invitation message containing the network address, including the listening port of the initiating device, to a target mobile device through a page-mode messaging service supported by the digital mobile network system. *Id.* at 2:2–7. Initiating mobile device further utilizes and incorporates a unique identification number associated with the target mobile device into the invitation message to locate and contact the target mobile device within the wireless mobile network. *Id.* at 2:7–11. “Once the initiating mobile device receives a response from the target mobile device at the listening port, the two mobile devices are able to establish a reliable virtual connection through the underlying data packet-based network protocol in order to transfer data directly between the two mobile devices.” *Id.* at 2:12–17.

An example digital mobile network system is illustrated in Figure 1 reproduced below.

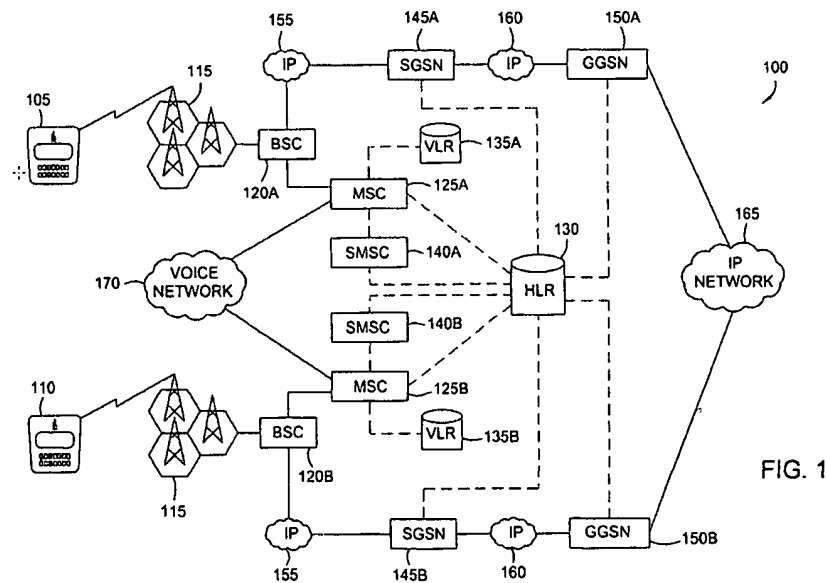

Figure 1 is a diagram of a Global System for Mobile communications (GSM) mobile networking system 100 including a first mobile device 105 and a second mobile device 110. *Id.* at 2:21–27. As disclosed in the

'925 patent, each of the mobile devices 105 and 110 includes a Subscriber Information Module (SIM) card that contains unique identification information that enables the GSM system 100 to locate the mobile devices within the network and route data to them. *Id.* at 2:40–44. The '925 patent further discloses that the GSM system 100 supports a page-mode messaging service, such as Short Message Service (SMS), that relies upon the underlying GSM mechanisms to resolve routing information to locate destination mobile devices. *Id.* at 3:14–18. Through use of a page-mode messaging service, such as SMS, an initiating mobile device transmits its IP address (and a listening port) in an invitation message to a target mobile device through the target device's telephone number. *Id.* at 4:26–31. When the target device receives the invitation message, it is able to contact the initiating mobile device through the received IP address and the two devices can establish a connection for a data transfer session. *Id.* at 4:31–35.

An example flow chart for establishing a data transfer session is illustrated in Figure 2 reproduced below.

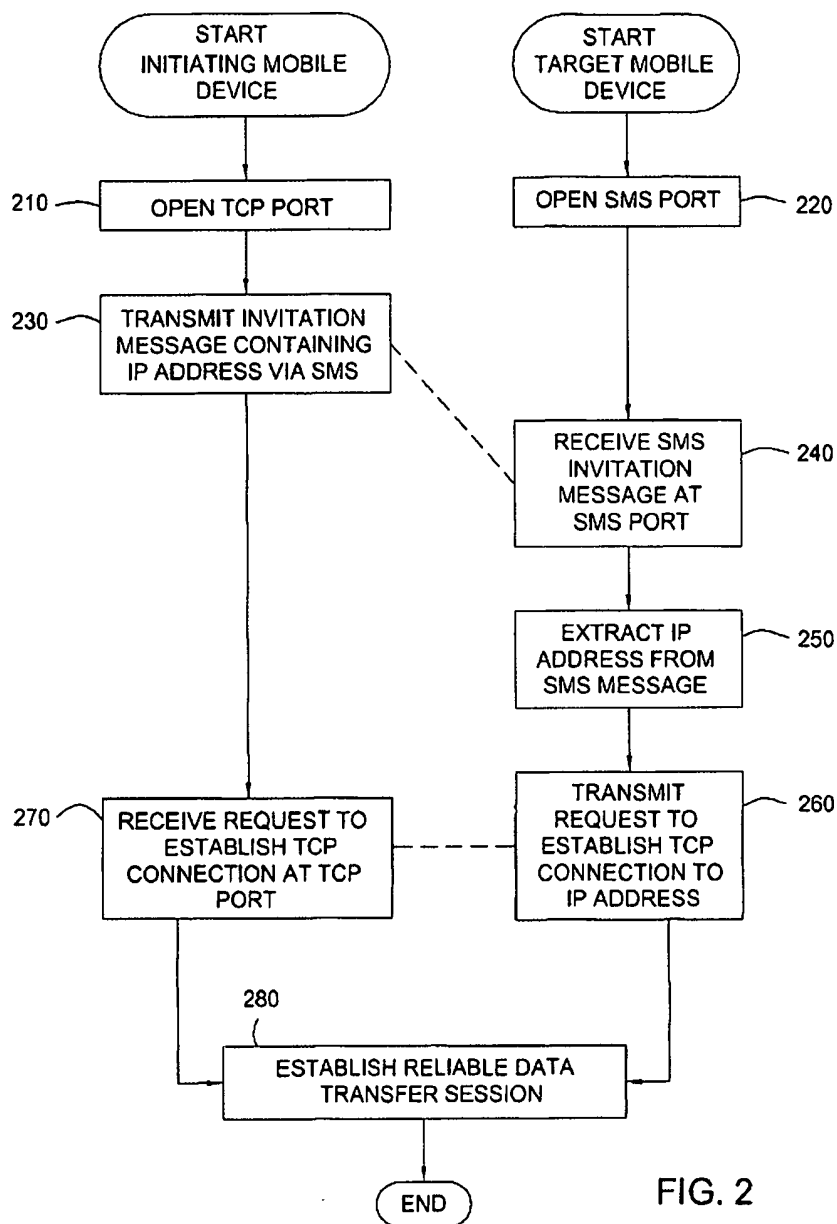

FIG. 2

Figure 2 is a flow chart depicting the steps taken by an initiating and target mobile device to establish a direct data transfer session. *Id.* at 4:35–38. At 210, the initiating mobile device opens a TCP port to listen for communications from the target mobile device. *Id.* at 4:38–40. At 220, the target mobile device similarly opens an SMS listening port to receive invitation SMS text messages at the specified SMS port. *Id.* at 4:40–42. At

Explore Litigation Insights

Docket Alarm provides insights to develop a more informed litigation strategy and the peace of mind of knowing you're on top of things.

Real-Time Litigation Alerts



Keep your litigation team up-to-date with **real-time alerts** and advanced team management tools built for the enterprise, all while greatly reducing PACER spend.

Our comprehensive service means we can handle Federal, State, and Administrative courts across the country.

Advanced Docket Research



With over 230 million records, Docket Alarm's cloud-native docket research platform finds what other services can't. Coverage includes Federal, State, plus PTAB, TTAB, ITC and NLRB decisions, all in one place.

Identify arguments that have been successful in the past with full text, pinpoint searching. Link to case law cited within any court document via Fastcase.

Analytics At Your Fingertips



Learn what happened the last time a particular judge, opposing counsel or company faced cases similar to yours.

Advanced out-of-the-box PTAB and TTAB analytics are always at your fingertips.

API

Docket Alarm offers a powerful API (application programming interface) to developers that want to integrate case filings into their apps.

LAW FIRMS

Build custom dashboards for your attorneys and clients with live data direct from the court.

Automate many repetitive legal tasks like conflict checks, document management, and marketing.

FINANCIAL INSTITUTIONS

Litigation and bankruptcy checks for companies and debtors.

E-DISCOVERY AND LEGAL VENDORS

Sync your system to PACER to automate legal marketing.